

USB1100-30-A Datasheet

www.digi-electronics.com



<https://www.DiGi-Electronics.com>

DiGi Electronics Part Number	USB1100-30-A-DG
Manufacturer	GCT
Manufacturer Product Number	USB1100-30-A
Description	USB3.0 A DUAL SKT, THRU HOLE, R/
Detailed Description	USB-A (USB TYPE-A), Stacked USB 3.2 Gen 1 (USB 3 .1 Gen 1, Superspeed (USB 3.0)) Receptacle Connector 18 Position Through Hole, Right Angle

This model USB1100-30-A is available at DiGi Electronics.

DiGi Electronics offers a global database of semiconductor and electronic component datasheets.

We welcome your inquiries regarding pricing, lead time, or other product-related questions.

 [Request a Quote](#)

 [Datasheet Search](#)



Tel: +00 852-30501935

RFQ Email: Info@DiGi-Electronics.com

DiGi is a global authorized distributor of electronic components.

Purchase and inquiry

Manufacturer Product Number:

USB1100-30-A

Series:

USB1100

Connector Type:

USB-A (USB TYPE-A), Stacked

Gender:

Receptacle

Mounting Type:

Through Hole, Right Angle

Termination:

Solder

Ingress Protection:

-

Number of Ports:

2

Voltage - Rated:

100VAC

Shielding:

Shielded

Shell/Shielding Material:

Steel (SUS201)

Insulation Color:

Blue

Manufacturer:

GCT

Product Status:

Active

Number of Contacts:

18

Specifications:

USB 3.2 Gen 1 (USB 3.1 Gen 1, Superspeed (USB 3.0))

Mounting Feature:

Horizontal

Features:

Board Lock

Operating Temperature:

-55°C ~ 85°C

Current Rating (Amps):

0.25A, 1.8A

Mating Cycles:

5000

Contact Finish:

Gold

Material Flammability Rating:

UL94 V-0

Base Product Number:

USB1100

Environmental & Export classification

RoHS Status:

ROHS3 Compliant

REACH Status:

REACH Unaffected

HTSUS:

8536.69.4040

Moisture Sensitivity Level (MSL):

1 (Unlimited)

ECCN:

EAR99

PRODUCT SPECIFICATION

Part Number	USB1100	Rev	A	Date	09/01/14		
Product Description	USB 3.0 Dual Receptacle, Type A, Top Mount, Through-Hole, Horizontal			Page	1		
Doc Number	USB1100	Prepared	AO	Checked	RM	Approved	VJ

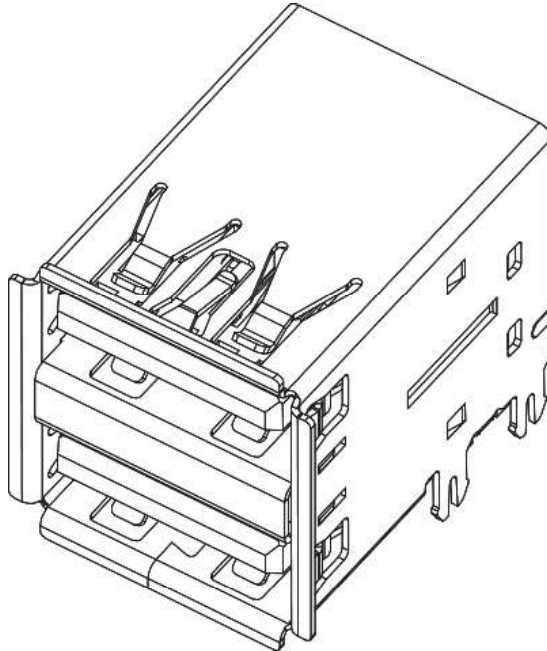

USB1100-30-A GCT USB3.0 A DUAL 2KT, THRU HOLE, K1

PRODUCT SPECIFICATION

Part Number	USB1100	Rev	A	Date	09/01/14
Product Description	USB 3.0 Dual Receptacle, Type A, Top Mount, Through-Hole, Horizontal			Page	2
Doc Number	USB1100	Prepared	AO	Checked	RM
				Approved	VJ

1.0 SCOPE.

This specification covers performance, tests and quality requirements for the USB Receptacle USB1100 (Type A, Through-Hole, Horizontal, Top Mount).

2.0 PRODUCT NAME AND PART NUMBER.

USB 3.0 Dual Receptacle, Type A, Through-Hole, Top Mount, Horizontal, USB1100.

3.0 PRODUCT SHAPE, DIMENSIONS AND MATERIAL.

Please refer to drawings.

4.0 RATINGS.

- 4.1 Current rating 0.25A (Signal Pins 2,3,5,6,7,8,9), 1.8A (Power Pins 1,4)
- 4.2 Voltage rating 100 V AC/DC
- 4.3 Operating Temperature Range -55°C to +85°C

5.0 TEST AND MEASUREMENT CONDITIONS.

Product is designed to meet electrical, mechanical and environmental performance requirements specified in Paragraph 6.0. All tests are performed in ambient conditions unless otherwise specified.

6.0 PERFORMANCE.

Item	Test Condition	Requirement
Examination of Product	Visual, dimensional and functional inspection as per quality plan.	Product shall meet requirements of product drawing and specification.

PRODUCT SPECIFICATION

Part Number	USB1100	Rev	A	Date	09/01/14
Product Description	USB 3.0 Dual Receptacle, Type A, Top Mount, Through-Hole, Horizontal			Page	3
Doc Number	USB1100	Prepared	AO	Checked	RM
				Approved	VJ

6.1 Electrical Performance.

Item	Test Condition	Requirement
Low-signal Level Contact Resistance	Mate connectors, measure by dry circuit, 20mV Max., 100mA Max. In accordance with EIA-364-23.	30mΩ Max.
Insulation Resistance	Unmated connectors, apply 100 V DC between adjacent terminals. In accordance with EIA-364-21.	1000 M Ω Min.
Dielectric Withstanding Voltage	Test between adjacent contacts of unmated connectors. In accordance with EIA-364-20.	100 V AC Min. at sea level for 1 minute. No discharge, flashover or breakdown.
Temperature Rise	Mate connector: measure the temperature rise when the maximum AC rated current is passed. In accordance with EIA-364-70.	30°C max. change allowed.

6.2 Mechanical Performance.

Item	Test Condition	Requirement
Mating / Unmating Force	Mated and unmated at rate of 12.5mm cycles per minute. In accordance with EIA-364-13.	Mating force: 35N Max. Un-mating force: 10N Min.
Durability	Insertion and withdrawal are repeated with card for 5,000 cycles at the frequency of 500 Cycles (automatically) & 200 Cycles (manually) / hour max. Mating force of 35N Max.& Unmating force 8N Min. In accordance with EIA-364-09.	Appearance: No breakdown Mating force :35N max. Un-mating force :8N min. after test. LLCR: 40 milliohm max.
Vibration	No discontinuities of 1μS or longer duration when mated USB connectors are subjected to 3.10 GRMS. 15 minutes in each of three mutually perpendicular planes. In accordance with EIA-364-28 Test Condition VII, Test Letter D.	No Damage Discontinuity: 1 μsecond Max.

PRODUCT SPECIFICATION

Part Number	USB1100	Rev	A	Date	09/01/14		
Product Description	USB 3.0 Dual Receptacle, Type A, Top Mount, Through-Hole, Horizontal			Page	4		
Doc Number	USB1100	Prepared	AO	Checked	RM	Approved	VJ

6.3 Environmental Performance and Others.

Item	Test Condition	Requirement
Thermal Shock	Mate module and subject to follow condition for 10 cycles. At -55°C to +85°C. In accordance with EIA-364-32, test condition I.	No Damage 10 mΩ max. change allowed.
Mechanical Shock	Mated USB connectors are subjected to 11ms duration 30Gs half-sine shock pulses. Three shocks in each direction applied along three mutually perpendicular planes for 18 shocks. In accordance with EIA-364-27, test condition H.	No Damage Discontinuity: 1.0 μsecond max.
Humidity & Temperature Cycling Test	Mate Connector and expose to temperature of 25~65°C±3, 50~80%RH±3, Ramp times should be 0.5 hour & dwell should be 1 hour, 1 cycle 24H. Dwell times start when the temperature is stabilized within the specified levels. In accordance with EIA-364-31, Test condition A.	No Damage 10 mΩ max. change allowed.
Temperature Life	Subject mated connectors to temperature life at 105°C for 120 hours. Measure Signal. In accordance with EIA-364-17, Test condition A.	No Damage 10 mΩ max. change allowed.
Solderability	Dip solder-tails in flux then immerse in solder bath at 255±5 °C up to 0.5mm from the bottom of the housing for 5 seconds. In accordance with EIA-364-52, Category 2.	95% of immersed area must show no voids, pin holes.

02B1100-30-A GCT U2B3:0 A DUAL 2KT, THRU HOLE, K1

PRODUCT SPECIFICATION

Part Number	USB1100	Rev	A	Date	09/01/14
Product Description	USB 3.0 Dual Receptacle, Type A, Top Mount, Through-Hole, Horizontal			Page	5
Doc Number	USB1100	Prepared	AO	Checked	RM
				Approved	VJ

Item	Test Condition	Requirement
Resistance to Solder Heat (Wave Soldering)	Heat: 260±5°C, 10+2/-0 sec. In accordance with EIA-364-56	Sample mounted on PCB and subject to wave soldering. Without deformation of case or excessive looseness of the terminals/pin (DIP only).
Resistance to Solder Heat (Reflow Soldering)	For procedures other than specified below, refer to IEC PUB, 68-2-20. Test Tb Method 1A or 2 Solder bath method Solder temperature: 260±5°C Immersion time: 10±1 second. Thickness of PCB: 0.8mm. In accordance with EIA-364-56	Without deformation of case or excessive looseness of the terminals/pin (SMT only).
Resistance to Solder Heat (Hand Soldering)	Solder iron method solder temperature: 350±10°C Immersion time: 3±1 seconds, however excessive pressure shall not be applied to the terminal	Without deformation of case or excessive looseness of the terminals/pin.

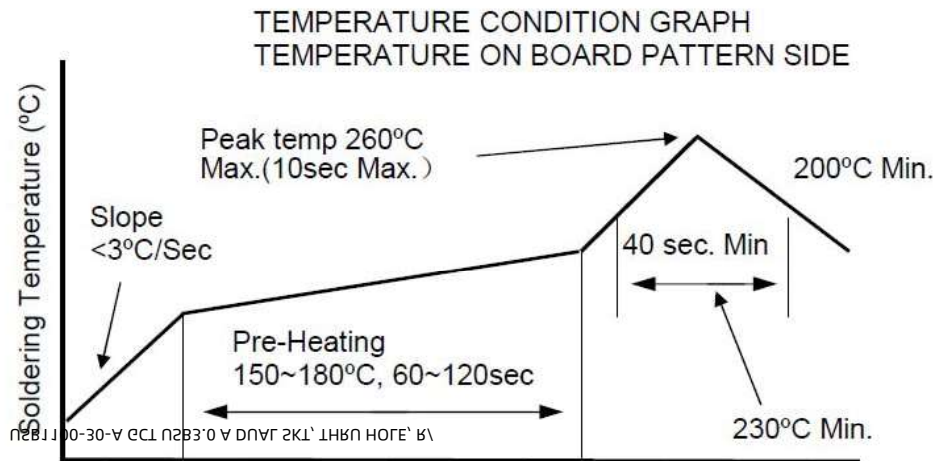

Fig 1 – Temperature profile of Reflow Soldering at 260°C Max.

PRODUCT SPECIFICATION

Part Number	USB1100	Rev	A	Date	09/01/14		
Product Description	USB 3.0 Dual Receptacle, Type A, Top Mount, Through-Hole, Horizontal			Page	6		
Doc Number	USB1100	Prepared	AO	Checked	RM	Approved	VJ

7.0 PRODUCT QUALIFICATION AND TEST SEQUENCE

Test Item	Test Group								
	1	2	3	4	5	6	7	8	9
Examination of Product	1, 3	1, 10	1, 6	1, 7	1, 6	1, 4	1, 4	1, 3	1, 3
Low-signal Contact Resistance		2, 9	2, 5	2, 4, 6	2, 9	2, 5			
Insulation Resistance					5				
Dielectric Withstanding Voltage		3, 8							
Temperature Rise	2								
Mating / Unmating Force		4, 7							
Durability		5							
Vibration			3						
Thermal Shock			4						
Mechanical Shock				5					
Humidity & Temperature Cycling		6							
Temperature Life				3					
Solderability							2		
Resistance to Wave Soldering Heat								2	
Resistance to Reflow Soldering Heat									2
Resistance to Hand Soldering Heat							3		
Sample Size	5	5	5	5	5	5	5	5	5

USB1100-30-A GCT USB3.0 A DUAL 2KT, THRU HOLE, K1

OUR CERTIFICATE

DiGi provide top-quality products and perfect service for customer worldwide through standardization, technological innovation and continuous improvement. DiGi through third-party certification, we stricly control the quality of products and services. Welcome your RFQ to

Email: Info@DiGi-Electronics.com



Tel: +00 852-30501935

RFQ Email: Info@DiGi-Electronics.com

DiGi is a global authorized distributor of electronic components.