

PVC4233 Datasheet



| | |
|------------------------------|--|
| DiGi Electronics Part Number | PVC4233-DG |
| Manufacturer | Cornell Dubilier Electronics (CDE) |
| Manufacturer Product Number | PVC4233 |
| Description | CAP FILM 3300PF 10% 400VDC RAD |
| Detailed Description | 3300 pF Film Capacitor 200V 400V Polyester Radial |

<https://www.DiGi-Electronics.com>

This model PVC4233 is available at DiGi Electronics.

DiGi Electronics offers a global database of semiconductor and electronic component datasheets.

We welcome your inquiries regarding pricing, lead time, or other product-related questions.

 [Request a Quote](#)

 [Datasheet Search](#)



Tel: +00 852-30501935

RFQ Email: Info@DiGi-Electronics.com

DiGi is a global authorized distributor of electronic components.

Purchase and inquiry

Manufacturer Product Number:

PVC4233

Series:

PVC

Capacitance:

3300 pF

Voltage Rating - AC:

200V

Dielectric Material:

Polyester

Mounting Type:

Through Hole

Size / Dimension:

0.299" Dia x 0.701" L (7.60mm x 17.80mm)

Termination:

PC Pins

Applications:

General Purpose

Features:

-

Manufacturer:

Cornell Dubilier Electronics (CDE)

Product Status:

Obsolete

Tolerance:

±10%

Voltage Rating - DC:

400V

Operating Temperature:

-55°C ~ 125°C

Package / Case:

Radial

Height - Seated (Max):

-

Lead Spacing:

0.500" (12.70mm)

Ratings:

-

Environmental & Export classification

RoHS Status:

ROHS3 Compliant

REACH Status:

REACH Unaffected

HTSUS:

8532.25.0070

Moisture Sensitivity Level (MSL):

1 (Unlimited)

ECCN:

EAR99

Type PVC Polyester and Polypropylene Film/Foil Capacitors

Polyester Film/Foil (100 V– 1000 V) and Polypropylene Film/Foil (1200 V - 2000 V)



The Type PVC is a sturdy film and extended foil construction ideal for bypass and coupling applications. Extended foil construction is as good as it gets for low DF and high current applications. The PVC is encapsulated in a rugged, flame retardant, epoxy coating with the leads crimped to provide secure seating on printed circuit boards.

Highlights

- ◆ RoHS Compliant
- ◆ Rugged epoxy case material meets UL94V0
- ◆ Film/foil polyester 100 – 1000 Vdc
- ◆ Film/foil polypropylene - 1200 Vdc to 2000 Vdc
- ◆ Non-inductively wound
- ◆ Non-polar
- ◆ Crimped leads for secure PC board insertion
- ◆ Lead material: tinned copper clad steel

Specifications

Capacitance Range: 0.001 μ F to 1.0 μ F

Capacitance Tolerance: \pm 10%

Voltage Range: Polyester: 100 Vdc to 1000 Vdc (70 Vac – 200 Vac 50/60 Hz)

Polypropylene: 1200 Vdc to 2000 Vdc (475 Vac – 500 Vac 50/60 Hz)

Operating Temperature Range: Polyester: -55°C to $+125^{\circ}\text{C}$

Polypropylene: -55°C to $+105^{\circ}\text{C}$

(Full rated voltage up to 85°C . Derate linearly to 50% rated voltage at max temperature)

Insulation Resistance (IR): Polyester: 100,000 $\text{M}\Omega$ for $\leq 0.25 \mu\text{F}$, 25,000 $\text{M}\Omega \cdot \mu\text{F}$ for $\geq 0.25 \mu\text{F}$

Polypropylene: 400,000 $\text{M}\Omega$ for $\leq 0.50 \mu\text{F}$, 200,000 $\text{M}\Omega \cdot \mu\text{F}$ for $\geq 0.50 \mu\text{F}$

After 2 minutes at rated voltage or 500V whichever is less. $+25^{\circ}\text{C}$

0.75% max for $<1200 \text{ V}$, 0.1% max for $\geq 1200 \text{ V}$. $+25^{\circ}\text{C}$

Dissipation Factor (DF): 250% rated voltage for $<1000 \text{ V}$, 200% rated voltage for $\geq 1000 \text{ V}$. 5 seconds, $+25^{\circ}\text{C}$

Dielectric Withstand Voltage: 500 hours at $+85^{\circ}\text{C}$, 1.5 times rated DC voltage

Life Test:

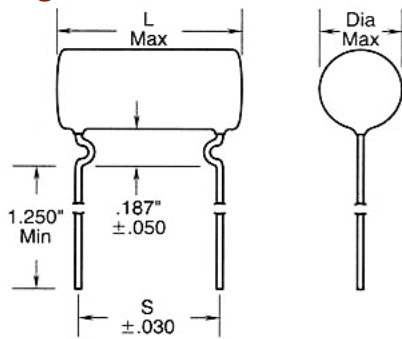

Complies with the EU Directive 2002/95/EC requirement restricting the use of Lead (Pb), Mercury (Hg), Cadmium (Cd), Hexavalent chromium (Cr(VI)), PolyBrominated Biphenyls (PBB) and PolyBrominated Diphenyl Ethers (PBDE).

Type PVC Polyester and Polypropylene Film/Foil Capacitors**Outline Drawing****Lead Pull Test**

Capacitor leads shall withstand a steady pull of 5 pounds applied radially to the capacitor body for 1 minute.

Lead Bend Test

Capacitor leads shall be bent without breakage below the lead crimp, first 90° in one direction then back to the original position and then 90° in the opposite direction.

Ratings

| Catalog Part Number | Cap (μF) | Inches | | | | Millimeters | | | |
|--------------------------|----------|--------|---------|----------------|-------|-------------|---------|----------------|-----|
| | | L Max | Dia Max | S Lead Spacing | ∅d | L Max | Dia Max | S Lead Spacing | ∅d |
| 100 Vdc / 70 Vac | | | | | | | | | |
| PVC1118 | 0.018 | 0.7 | 0.33 | 0.500 | 0.032 | 17.8 | 8.4 | 12.7 | 0.8 |
| PVC1122 | 0.022 | 0.7 | 0.35 | 0.500 | 0.032 | 17.8 | 8.9 | 12.7 | 0.8 |
| PVC1127 | 0.027 | 0.7 | 0.35 | 0.500 | 0.032 | 17.8 | 8.9 | 12.7 | 0.8 |
| PVC1133 | 0.033 | 0.7 | 0.35 | 0.500 | 0.032 | 17.8 | 8.9 | 12.7 | 0.8 |
| PVC114 | 0.040 | 0.7 | 0.35 | 0.500 | 0.032 | 17.8 | 8.9 | 12.7 | 0.8 |
| PVC1147 | 0.047 | 0.7 | 0.35 | 0.500 | 0.032 | 17.8 | 8.9 | 12.7 | 0.8 |
| PVC1156 | 0.056 | 0.7 | 0.38 | 0.500 | 0.032 | 17.8 | 9.7 | 12.7 | 0.8 |
| PVC1168 | 0.068 | 0.7 | 0.38 | 0.500 | 0.032 | 17.8 | 9.7 | 12.7 | 0.8 |
| PVC1182 | 0.082 | 0.9 | 0.40 | 0.688 | 0.032 | 22.9 | 10.2 | 17.5 | 0.8 |
| PVC101 | 0.10 | 0.9 | 0.40 | 0.688 | 0.032 | 22.9 | 10.2 | 17.5 | 0.8 |
| PVC1015 | 0.15 | 0.9 | 0.45 | 0.688 | 0.032 | 22.9 | 11.4 | 17.5 | 0.8 |
| PVC1022 | 0.22 | 1.2 | 0.45 | 0.969 | 0.032 | 30.5 | 11.4 | 24.6 | 0.8 |
| PVC1025 | 0.25 | 1.2 | 0.50 | 0.969 | 0.032 | 30.5 | 12.7 | 24.6 | 0.8 |
| PVC1033 | 0.33 | 1.2 | 0.50 | 0.969 | 0.032 | 30.5 | 12.7 | 24.6 | 0.8 |
| PVC1039 | 0.39 | 1.6 | 0.50 | 1.344 | 0.032 | 40.6 | 12.7 | 34.1 | 0.8 |
| PVC1047 | 0.47 | 1.6 | 0.50 | 1.344 | 0.032 | 40.6 | 12.7 | 34.1 | 0.8 |
| PVC105 | 0.50 | 1.6 | 0.60 | 1.344 | 0.032 | 40.6 | 15.2 | 34.1 | 0.8 |
| PVC1056 | 0.56 | 1.6 | 0.60 | 1.344 | 0.032 | 40.6 | 15.2 | 34.1 | 0.8 |
| PVC1068 | 0.68 | 1.6 | 0.60 | 1.344 | 0.032 | 40.6 | 15.2 | 34.1 | 0.8 |
| PVC1082 | 0.82 | 1.6 | 0.65 | 1.344 | 0.032 | 40.6 | 16.5 | 34.1 | 0.8 |
| PVC11 | 1.00 | 1.6 | 0.70 | 1.344 | 0.032 | 40.6 | 17.8 | 34.1 | 0.8 |
| 200 Vdc / 140 Vac | | | | | | | | | |
| PVC211 | 0.010 | 0.7 | 0.33 | 0.500 | 0.032 | 17.8 | 8.4 | 12.7 | 0.8 |
| PVC2115 | 0.015 | 0.7 | 0.33 | 0.500 | 0.032 | 17.8 | 8.4 | 12.7 | 0.8 |
| PVC2118 | 0.018 | 0.7 | 0.33 | 0.500 | 0.032 | 17.8 | 8.4 | 12.7 | 0.8 |
| PVC212 | 0.020 | 0.7 | 0.33 | 0.500 | 0.032 | 17.8 | 8.4 | 12.7 | 0.8 |
| PVC2122 | 0.022 | 0.7 | 0.33 | 0.500 | 0.032 | 17.8 | 8.4 | 12.7 | 0.8 |
| PVC2133 | 0.033 | 0.9 | 0.38 | 0.688 | 0.032 | 22.9 | 9.7 | 17.5 | 0.8 |
| PVC2139 | 0.039 | 0.9 | 0.38 | 0.688 | 0.032 | 22.9 | 9.7 | 17.5 | 0.8 |
| PVC214 | 0.040 | 0.9 | 0.38 | 0.688 | 0.032 | 22.9 | 9.7 | 17.5 | 0.8 |
| PVC2147 | 0.047 | 0.9 | 0.38 | 0.688 | 0.032 | 22.9 | 9.7 | 17.5 | 0.8 |
| PVC215 | 0.050 | 0.9 | 0.38 | 0.688 | 0.032 | 22.9 | 9.7 | 17.5 | 0.8 |
| PVC2156 | 0.056 | 1.2 | 0.38 | 0.969 | 0.032 | 30.5 | 9.7 | 24.6 | 0.8 |

Type PVC Polyester and Polypropylene Film/Foil Capacitors

RoHS Compliant

| Catalog Part Number | Cap (μ F) | Inches | | | | Millimeters | | | |
|--------------------------|-------------------|----------|------------|-------------------|-----------------|-------------|------------|-------------------|-----------------|
| | | L Max | Dia Max | S Lead Spacing | \varnothing d | L Max | Dia Max | S Lead Spacing | \varnothing d |
| 200 Vdc / 140 Vac | | | | | | | | | |
| PVC2168 | 0.068 | 1.2 | 0.38 | 0.969 | 0.032 | 30.5 | 9.7 | 24.6 | 0.8 |
| PVC2182 | 0.082 | 1.2 | 0.40 | 0.969 | 0.032 | 30.5 | 10.2 | 24.6 | 0.8 |
| PVC201 | 0.10 | 1.2 | 0.40 | 0.969 | 0.032 | 30.5 | 10.2 | 24.6 | 0.8 |
| PVC2015 | 0.15 | 1.2 | 0.45 | 0.969 | 0.032 | 30.5 | 11.4 | 24.6 | 0.8 |
| PVC2022 | 0.22 | 1.2 | 0.50 | 0.969 | 0.032 | 30.5 | 12.7 | 24.6 | 0.8 |
| PVC2025 | 0.25 | 1.2 | 0.50 | 0.969 | 0.032 | 30.5 | 12.7 | 24.6 | 0.8 |
| PVC2027 | 0.27 | 1.6 | 0.47 | 1.344 | 0.032 | 40.6 | 11.9 | 34.1 | 0.8 |
| PVC2033 | 0.33 | 1.6 | 0.47 | 1.344 | 0.032 | 40.6 | 11.9 | 34.1 | 0.8 |
| PVC2047 | 0.47 | 1.6 | 0.56 | 1.344 | 0.032 | 40.6 | 14.2 | 34.1 | 0.8 |
| PVC205 | 0.50 | 1.6 | 0.56 | 1.344 | 0.032 | 40.6 | 14.2 | 34.1 | 0.8 |
| 400 Vdc / 200 Vac | | | | | | | | | |
| PVC421 | 0.0010 | 0.7 | 0.30 | 0.500 | 0.032 | 17.8 | 7.6 | 12.7 | 0.8 |
| PVC4222 | 0.0022 | 0.7 | 0.30 | 0.500 | 0.032 | 17.8 | 7.6 | 12.7 | 0.8 |
| PVC4233 | 0.0033 | 0.7 | 0.30 | 0.500 | 0.032 | 17.8 | 7.6 | 12.7 | 0.8 |
| PVC4247 | 0.0047 | 0.7 | 0.30 | 0.500 | 0.032 | 17.8 | 7.6 | 12.7 | 0.8 |
| PVC4268 | 0.0068 | 0.7 | 0.33 | 0.500 | 0.032 | 17.8 | 8.4 | 12.7 | 0.8 |
| PVC411 | 0.010 | 0.7 | 0.35 | 0.500 | 0.032 | 17.8 | 8.9 | 12.7 | 0.8 |
| PVC412 | 0.020 | 0.9 | 0.39 | 0.688 | 0.032 | 22.9 | 9.9 | 17.5 | 0.8 |
| PVC4133 | 0.033 | 0.9 | 0.40 | 0.688 | 0.032 | 22.9 | 10.2 | 17.5 | 0.8 |
| PVC4147 | 0.047 | 1.2 | 0.40 | 0.969 | 0.032 | 30.5 | 10.2 | 24.6 | 0.8 |
| PVC415 | 0.050 | 1.2 | 0.45 | 0.969 | 0.032 | 30.5 | 11.4 | 24.6 | 0.8 |
| PVC4156 | 0.056 | 1.2 | 0.45 | 0.969 | 0.032 | 30.5 | 11.4 | 24.6 | 0.8 |
| PVC4168 | 0.068 | 1.2 | 0.45 | 0.969 | 0.032 | 30.5 | 11.4 | 24.6 | 0.8 |
| PVC4182 | 0.082 | 1.2 | 0.52 | 0.969 | 0.032 | 30.5 | 13.2 | 24.6 | 0.8 |
| PVC401 | 0.10 | 1.2 | 0.53 | 0.969 | 0.032 | 30.5 | 13.5 | 24.6 | 0.8 |
| PVC4015 | 0.15 | 1.2 | 0.57 | 0.969 | 0.032 | 30.5 | 14.5 | 24.6 | 0.8 |
| PVC4018 | 0.18 | 1.6 | 0.60 | 1.344 | 0.032 | 40.6 | 15.2 | 34.1 | 0.8 |
| PVC4022 | 0.22 | 1.6 | 0.60 | 1.344 | 0.032 | 40.6 | 15.2 | 34.1 | 0.8 |
| PVC4025 | 0.25 | 1.6 | 0.65 | 1.344 | 0.032 | 40.6 | 16.5 | 34.1 | 0.8 |
| PVC4033 | 0.33 | 1.6 | 0.65 | 1.344 | 0.032 | 40.6 | 16.5 | 34.1 | 0.8 |
| PVC4039 | 0.39 | 1.6 | 0.72 | 1.344 | 0.032 | 40.6 | 18.3 | 34.1 | 0.8 |
| PVC4047 | 0.47 | 1.6 | 0.80 | 1.344 | 0.032 | 40.6 | 20.3 | 34.1 | 0.8 |
| 600 Vdc / 200 Vac | | | | | | | | | |
| PVC621 | 0.0010 | 0.7 | 0.30 | 0.500 | 0.032 | 17.8 | 7.6 | 12.7 | 0.8 |
| PVC6212 | 0.0012 | 0.7 | 0.33 | 0.500 | 0.032 | 17.8 | 8.4 | 12.7 | 0.8 |
| PVC6215 | 0.0015 | 0.7 | 0.33 | 0.500 | 0.032 | 17.8 | 8.4 | 12.7 | 0.8 |
| PVC6218 | 0.0018 | 0.7 | 0.33 | 0.500 | 0.032 | 17.8 | 8.4 | 12.7 | 0.8 |
| PVC622 | 0.0020 | 0.7 | 0.33 | 0.500 | 0.032 | 17.8 | 8.4 | 12.7 | 0.8 |
| PVC6222 | 0.0022 | 0.7 | 0.33 | 0.500 | 0.032 | 17.8 | 8.4 | 12.7 | 0.8 |
| PVC6225 | 0.0025 | 0.7 | 0.34 | 0.500 | 0.032 | 17.8 | 8.6 | 12.7 | 0.8 |
| PVC6227 | 0.0027 | 0.7 | 0.35 | 0.500 | 0.032 | 17.8 | 8.9 | 12.7 | 0.8 |
| PVC623 | 0.0030 | 0.7 | 0.35 | 0.500 | 0.032 | 17.8 | 8.9 | 12.7 | 0.8 |
| PVC6233 | 0.0033 | 0.7 | 0.35 | 0.500 | 0.032 | 17.8 | 8.9 | 12.7 | 0.8 |
| PVC6239 | 0.0039 | 0.7 | 0.38 | 0.500 | 0.032 | 17.8 | 9.7 | 12.7 | 0.8 |
| PVC624 | 0.0040 | 0.7 | 0.38 | 0.500 | 0.032 | 17.8 | 9.7 | 12.7 | 0.8 |
| PVC6247 | 0.0047 | 0.7 | 0.38 | 0.500 | 0.032 | 17.8 | 9.7 | 12.7 | 0.8 |
| PVC625 | 0.0050 | 0.7 | 0.38 | 0.500 | 0.032 | 17.8 | 9.7 | 12.7 | 0.8 |
| PVC6256 | 0.0056 | 0.7 | 0.40 | 0.500 | 0.032 | 17.8 | 10.2 | 12.7 | 0.8 |

Type PVC Polyester and Polypropylene Film/Foil Capacitors**RoHS Compliant**

| Catalog Part Number | Cap (μ F) | Inches | | | | Millimeters | | | |
|---------------------------|-------------------|----------|------------|-------------------|-----------------|-------------|------------|-------------------|-----------------|
| | | L Max | Dia Max | S Lead Spacing | \varnothing d | L Max | Dia Max | S Lead Spacing | \varnothing d |
| 600 Vdc / 200 Vac | | | | | | | | | |
| PVC626 | 0.0060 | 0.7 | 0.40 | 0.500 | 0.032 | 17.8 | 10.2 | 12.7 | 0.8 |
| PVC6268 | 0.0068 | 0.7 | 0.40 | 0.500 | 0.032 | 17.8 | 10.2 | 12.7 | 0.8 |
| PVC6275 | 0.0075 | 0.7 | 0.40 | 0.500 | 0.032 | 17.8 | 10.2 | 12.7 | 0.8 |
| PVC628 | 0.0080 | 0.9 | 0.40 | 0.688 | 0.032 | 22.9 | 10.2 | 17.5 | 0.8 |
| PVC6282 | 0.0082 | 0.9 | 0.40 | 0.688 | 0.032 | 22.9 | 10.2 | 17.5 | 0.8 |
| PVC611 | 0.010 | 0.9 | 0.40 | 0.688 | 0.032 | 22.9 | 10.2 | 17.5 | 0.8 |
| PVC6112 | 0.012 | 0.9 | 0.40 | 0.688 | 0.032 | 22.9 | 10.2 | 17.5 | 0.8 |
| PVC6115 | 0.015 | 0.9 | 0.40 | 0.688 | 0.032 | 22.9 | 10.2 | 17.5 | 0.8 |
| PVC6118 | 0.018 | 0.9 | 0.45 | 0.688 | 0.032 | 22.9 | 11.4 | 17.5 | 0.8 |
| PVC612 | 0.020 | 0.9 | 0.45 | 0.688 | 0.032 | 22.9 | 11.4 | 17.5 | 0.8 |
| PVC6122 | 0.022 | 0.9 | 0.45 | 0.688 | 0.032 | 22.9 | 11.4 | 17.5 | 0.8 |
| PVC6125 | 0.025 | 0.9 | 0.45 | 0.688 | 0.032 | 22.9 | 11.4 | 17.5 | 0.8 |
| PVC6127 | 0.027 | 1.2 | 0.45 | 0.969 | 0.032 | 30.5 | 11.4 | 24.6 | 0.8 |
| PVC613 | 0.030 | 1.2 | 0.45 | 0.969 | 0.032 | 30.5 | 11.4 | 24.6 | 0.8 |
| PVC6133 | 0.033 | 1.2 | 0.45 | 0.969 | 0.032 | 30.5 | 11.4 | 24.6 | 0.8 |
| PVC6139 | 0.039 | 1.2 | 0.56 | 0.969 | 0.032 | 30.5 | 14.2 | 24.6 | 0.8 |
| PVC614 | 0.040 | 1.2 | 0.56 | 0.969 | 0.032 | 30.5 | 14.2 | 24.6 | 0.8 |
| PVC6147 | 0.047 | 1.2 | 0.56 | 0.969 | 0.032 | 30.5 | 14.2 | 24.6 | 0.8 |
| PVC615 | 0.050 | 1.2 | 0.56 | 0.969 | 0.032 | 30.5 | 14.2 | 24.6 | 0.8 |
| PVC6156 | 0.056 | 1.2 | 0.60 | 0.969 | 0.032 | 30.5 | 15.2 | 24.6 | 0.8 |
| PVC6168 | 0.068 | 1.2 | 0.60 | 0.969 | 0.032 | 30.5 | 15.2 | 24.6 | 0.8 |
| PVC6182 | 0.082 | 1.2 | 0.65 | 0.969 | 0.032 | 30.5 | 16.5 | 24.6 | 0.8 |
| PVC601 | 0.10 | 1.2 | 0.65 | 0.969 | 0.032 | 30.5 | 16.5 | 24.6 | 0.8 |
| PVC6012 | 0.12 | 1.6 | 0.70 | 1.344 | 0.032 | 40.6 | 17.8 | 34.1 | 0.8 |
| PVC6015 | 0.15 | 1.6 | 0.70 | 1.344 | 0.032 | 40.6 | 17.8 | 34.1 | 0.8 |
| PVC6018 | 0.18 | 1.6 | 0.80 | 1.344 | 0.032 | 40.6 | 20.3 | 34.1 | 0.8 |
| PVC602 | 0.20 | 1.6 | 0.80 | 1.344 | 0.032 | 40.6 | 20.3 | 34.1 | 0.8 |
| PVC6022 | 0.22 | 1.6 | 0.80 | 1.344 | 0.032 | 40.6 | 20.3 | 34.1 | 0.8 |
| PVC6025 | 0.25 | 1.6 | 0.80 | 1.344 | 0.032 | 40.6 | 20.3 | 34.1 | 0.8 |
| PVC6033 | 0.33 | 1.81 | 0.89 | 1.531 | 0.032 | 46.0 | 22.6 | 38.9 | 0.8 |
| 1000 Vdc / 200 Vac | | | | | | | | | |
| PVC1021 | 0.0010 | 0.7 | 0.33 | 0.500 | 0.032 | 17.8 | 8.4 | 12.7 | 0.8 |
| PVC10215 | 0.0015 | 0.7 | 0.33 | 0.500 | 0.032 | 17.8 | 8.4 | 12.7 | 0.8 |
| PVC10218 | 0.0018 | 0.7 | 0.35 | 0.500 | 0.032 | 17.8 | 8.9 | 12.7 | 0.8 |
| PVC10222 | 0.0022 | 0.7 | 0.35 | 0.500 | 0.032 | 17.8 | 8.9 | 12.7 | 0.8 |
| PVC10233 | 0.0033 | 0.9 | 0.35 | 0.688 | 0.032 | 22.9 | 8.9 | 17.5 | 0.8 |
| PVC10247 | 0.0047 | 0.9 | 0.40 | 0.688 | 0.032 | 22.9 | 10.2 | 17.5 | 0.8 |
| PVC10256 | 0.0056 | 0.9 | 0.43 | 0.688 | 0.032 | 22.9 | 10.9 | 17.5 | 0.8 |
| PVC10268 | 0.0068 | 0.9 | 0.43 | 0.688 | 0.032 | 22.9 | 10.9 | 17.5 | 0.8 |
| PVC10282 | 0.0082 | 0.9 | 0.48 | 0.688 | 0.032 | 22.9 | 12.2 | 17.5 | 0.8 |
| PVC1011 | 0.010 | 0.9 | 0.48 | 0.688 | 0.032 | 22.9 | 12.2 | 17.5 | 0.8 |
| PVC10115 | 0.015 | 1.2 | 0.48 | 0.969 | 0.032 | 30.5 | 12.2 | 24.6 | 0.8 |
| PVC10118 | 0.018 | 1.2 | 0.58 | 0.969 | 0.032 | 30.5 | 14.7 | 24.6 | 0.8 |
| PVC10122 | 0.022 | 1.2 | 0.58 | 0.969 | 0.032 | 30.5 | 14.7 | 24.6 | 0.8 |
| PVC10127 | 0.027 | 1.2 | 0.65 | 0.969 | 0.032 | 30.5 | 16.5 | 24.6 | 0.8 |
| PVC10133 | 0.033 | 1.2 | 0.65 | 0.969 | 0.032 | 30.5 | 16.5 | 24.6 | 0.8 |

Type PVC Polyester and Polypropylene Film/Foil Capacitors**RoHS Compliant**

| Catalog Part Number | Cap (μ F) | Inches | | | | Millimeters | | | |
|---------------------------|-------------------|----------|------------|-------------------|-----------------|-------------|------------|-------------------|-----------------|
| | | L Max | Dia Max | S Lead Spacing | \varnothing d | L Max | Dia Max | S Lead Spacing | \varnothing d |
| 1000 Vdc / 200 Vac | | | | | | | | | |
| PVC10139 | 0.039 | 1.6 | 0.65 | 1.344 | 0.032 | 40.6 | 16.5 | 34.1 | 0.8 |
| PVC10147 | 0.047 | 1.6 | 0.65 | 1.344 | 0.032 | 40.6 | 16.5 | 34.1 | 0.8 |
| PVC10156 | 0.056 | 1.6 | 0.75 | 1.344 | 0.032 | 40.6 | 19.1 | 34.1 | 0.8 |
| PVC10168 | 0.068 | 1.6 | 0.75 | 1.344 | 0.032 | 40.6 | 19.1 | 34.1 | 0.8 |
| PVC10182 | 0.082 | 1.6 | 0.85 | 1.344 | 0.032 | 40.6 | 21.6 | 34.1 | 0.8 |
| PVC10010 | 0.100 | 1.6 | 0.85 | 1.344 | 0.032 | 40.6 | 21.6 | 34.1 | 0.8 |
| 1200 Vdc / 475 Vac | | | | | | | | | |
| PVC1221 | 0.0010 | 1.25 | 0.42 | 0.969 | 0.032 | 31.8 | 10.7 | 24.6 | 0.8 |
| PVC12212 | 0.0012 | 1.25 | 0.42 | 0.969 | 0.032 | 31.8 | 10.7 | 24.6 | 0.8 |
| PVC12215 | 0.0015 | 1.25 | 0.42 | 0.969 | 0.032 | 31.8 | 10.7 | 24.6 | 0.8 |
| PVC12218 | 0.0018 | 1.25 | 0.42 | 0.969 | 0.032 | 31.8 | 10.7 | 24.6 | 0.8 |
| PVC12222 | 0.0022 | 1.25 | 0.42 | 0.969 | 0.032 | 31.8 | 10.7 | 24.6 | 0.8 |
| PVC12227 | 0.0027 | 1.25 | 0.42 | 0.969 | 0.032 | 31.8 | 10.7 | 24.6 | 0.8 |
| PVC12233 | 0.0033 | 1.25 | 0.42 | 0.969 | 0.032 | 31.8 | 10.7 | 24.6 | 0.8 |
| PVC12239 | 0.0039 | 1.25 | 0.42 | 0.969 | 0.032 | 31.8 | 10.7 | 24.6 | 0.8 |
| PVC12247 | 0.0047 | 1.25 | 0.42 | 0.969 | 0.032 | 31.8 | 10.7 | 24.6 | 0.8 |
| PVC12256 | 0.0056 | 1.25 | 0.44 | 0.969 | 0.032 | 31.8 | 11.2 | 24.6 | 0.8 |
| PVC12268 | 0.0068 | 1.25 | 0.47 | 0.969 | 0.032 | 31.8 | 11.9 | 24.6 | 0.8 |
| PVC12282 | 0.0082 | 1.25 | 0.50 | 0.969 | 0.032 | 31.8 | 12.7 | 24.6 | 0.8 |
| PVC1211 | 0.010 | 1.25 | 0.53 | 0.969 | 0.032 | 31.8 | 13.5 | 24.6 | 0.8 |
| PVC12112 | 0.012 | 1.25 | 0.57 | 0.969 | 0.032 | 31.8 | 14.5 | 24.6 | 0.8 |
| PVC12115 | 0.015 | 1.25 | 0.61 | 0.969 | 0.032 | 31.8 | 15.5 | 24.6 | 0.8 |
| PVC12118 | 0.018 | 1.65 | 0.56 | 1.344 | 0.032 | 41.9 | 14.2 | 34.1 | 0.8 |
| PVC12122 | 0.022 | 1.65 | 0.60 | 1.344 | 0.032 | 41.9 | 15.2 | 34.1 | 0.8 |
| PVC12127 | 0.027 | 1.65 | 0.65 | 1.344 | 0.032 | 41.9 | 16.5 | 34.1 | 0.8 |
| PVC12133 | 0.033 | 1.65 | 0.70 | 1.344 | 0.032 | 41.9 | 17.8 | 34.1 | 0.8 |
| PVC12139 | 0.039 | 1.65 | 0.74 | 1.344 | 0.032 | 41.9 | 18.8 | 34.1 | 0.8 |
| PVC12147 | 0.047 | 1.65 | 0.80 | 1.344 | 0.032 | 41.9 | 20.3 | 34.1 | 0.8 |
| 1600 Vdc / 475 Vac | | | | | | | | | |
| PVC1621 | 0.0010 | 1.25 | 0.42 | 0.969 | 0.032 | 31.8 | 10.7 | 24.6 | 0.8 |
| PVC16215 | 0.0015 | 1.25 | 0.42 | 0.969 | 0.032 | 31.8 | 10.7 | 24.6 | 0.8 |
| PVC16222 | 0.0022 | 1.25 | 0.42 | 0.969 | 0.032 | 31.8 | 10.7 | 24.6 | 0.8 |
| PVC16227 | 0.0027 | 1.25 | 0.42 | 0.969 | 0.032 | 31.8 | 10.7 | 24.6 | 0.8 |
| PVC1623 | 0.0030 | 1.25 | 0.42 | 0.969 | 0.032 | 31.8 | 10.7 | 24.6 | 0.8 |
| PVC16233 | 0.0033 | 1.25 | 0.42 | 0.969 | 0.032 | 31.8 | 10.7 | 24.6 | 0.8 |
| PVC1624 | 0.0040 | 1.25 | 0.42 | 0.969 | 0.032 | 31.8 | 10.7 | 24.6 | 0.8 |
| PVC16247 | 0.0047 | 1.25 | 0.42 | 0.969 | 0.032 | 31.8 | 10.7 | 24.6 | 0.8 |
| PVC1625 | 0.0050 | 1.25 | 0.42 | 0.969 | 0.032 | 31.8 | 10.7 | 24.6 | 0.8 |
| PVC1626 | 0.0060 | 1.25 | 0.44 | 0.969 | 0.032 | 31.8 | 11.2 | 24.6 | 0.8 |
| PVC16268 | 0.0068 | 1.25 | 0.47 | 0.969 | 0.032 | 31.8 | 11.9 | 24.6 | 0.8 |
| PVC1627 | 0.0070 | 1.25 | 0.50 | 0.969 | 0.032 | 31.8 | 12.7 | 24.6 | 0.8 |
| PVC16275 | 0.0075 | 1.25 | 0.50 | 0.969 | 0.032 | 31.8 | 12.7 | 24.6 | 0.8 |
| PVC1628 | 0.0080 | 1.25 | 0.50 | 0.969 | 0.032 | 31.8 | 12.7 | 24.6 | 0.8 |
| PVC16282 | 0.0082 | 1.25 | 0.50 | 0.969 | 0.032 | 31.8 | 12.7 | 24.6 | 0.8 |

Type PVC Polyester and Polypropylene Film/Foil Capacitors**RoHS Compliant**

| Catalog Part Number | Cap (μ F) | Inches | | | | Millimeters | | | |
|---------------------------|-------------------|----------|------------|-------------------|-----------------|-------------|------------|-------------------|-----------------|
| | | L Max | Dia Max | S Lead Spacing | \varnothing d | L Max | Dia Max | S Lead Spacing | \varnothing d |
| 1600 Vdc / 475 Vac | | | | | | | | | |
| PVC1611 | 0.010 | 1.25 | 0.53 | 0.969 | 0.032 | 31.8 | 13.5 | 24.6 | 0.8 |
| PVC16115 | 0.015 | 1.25 | 0.61 | 1.344 | 0.032 | 33.8 | 15.5 | 34.1 | 0.8 |
| PVC1612 | 0.020 | 1.65 | 0.60 | 1.344 | 0.032 | 41.9 | 15.2 | 34.1 | 0.8 |
| PVC16122 | 0.022 | 1.65 | 0.60 | 1.344 | 0.032 | 41.9 | 15.2 | 34.1 | 0.8 |
| PVC16133 | 0.033 | 1.65 | 0.70 | 1.344 | 0.032 | 41.9 | 17.8 | 34.1 | 0.8 |
| PVC16147 | 0.047 | 1.65 | 0.80 | 1.344 | 0.032 | 41.9 | 20.3 | 34.1 | 0.8 |
| PVC1615 | 0.050 | 1.65 | 0.85 | 1.344 | 0.032 | 41.9 | 21.6 | 34.1 | 0.8 |
| 2000 Vdc / 500 Vac | | | | | | | | | |
| PVC2X21 | 0.0010 | 1.25 | 0.33 | 0.969 | 0.032 | 31.8 | 8.4 | 24.6 | 0.8 |
| PVC2X212 | 0.0012 | 1.25 | 0.34 | 0.969 | 0.032 | 31.8 | 8.6 | 24.6 | 0.8 |
| PVC2X215 | 0.0015 | 1.25 | 0.36 | 0.969 | 0.032 | 31.8 | 9.1 | 24.6 | 0.8 |
| PVC2X218 | 0.0018 | 1.25 | 0.38 | 0.969 | 0.032 | 31.8 | 9.7 | 24.6 | 0.8 |
| PVC2X222 | 0.0022 | 1.25 | 0.39 | 0.969 | 0.032 | 31.8 | 9.9 | 24.6 | 0.8 |
| PVC2X227 | 0.0027 | 1.25 | 0.42 | 0.969 | 0.032 | 31.8 | 10.7 | 24.6 | 0.8 |
| PVC2X233 | 0.0033 | 1.25 | 0.44 | 0.969 | 0.032 | 31.8 | 11.2 | 24.6 | 0.8 |
| PVC2X239 | 0.0039 | 1.25 | 0.47 | 0.969 | 0.032 | 31.8 | 11.9 | 24.6 | 0.8 |
| PVC2X247 | 0.0047 | 1.25 | 0.5 | 0.969 | 0.032 | 31.8 | 12.7 | 24.6 | 0.8 |
| PVC2X256 | 0.0056 | 1.25 | 0.53 | 0.969 | 0.032 | 31.8 | 13.5 | 24.6 | 0.8 |
| PVC2X268 | 0.0068 | 1.25 | 0.56 | 0.969 | 0.032 | 31.8 | 14.2 | 24.6 | 0.8 |
| PVC2X282 | 0.0082 | 1.25 | 0.60 | 0.969 | 0.032 | 31.8 | 15.2 | 24.6 | 0.8 |
| PVC2X11 | 0.0100 | 1.25 | 0.65 | 0.969 | 0.032 | 31.8 | 16.5 | 24.6 | 0.8 |
| PVC2X112 | 0.0120 | 1.65 | 0.58 | 1.344 | 0.032 | 41.9 | 14.7 | 34.1 | 0.8 |
| PVC2X115 | 0.0150 | 1.65 | 0.63 | 1.344 | 0.032 | 41.9 | 16.0 | 34.1 | 0.8 |
| PVC2X118 | 0.018 | 1.65 | 0.67 | 1.344 | 0.032 | 41.9 | 17.0 | 34.1 | 0.8 |
| PVC2X122 | 0.022 | 1.65 | 0.73 | 1.344 | 0.032 | 41.9 | 18.5 | 34.1 | 0.8 |
| PVC2X127 | 0.027 | 1.65 | 0.78 | 1.344 | 0.032 | 41.9 | 19.8 | 34.1 | 0.8 |
| PVC2X133 | 0.033 | 1.65 | 0.85 | 1.344 | 0.032 | 41.9 | 21.6 | 34.1 | 0.8 |

Part Numbering System

| PVC | 4 | 01 |
|--------|-------------|-------------------|
| Series | Voltage | Capacitance |
| PVC | 1 = 100 V | 21 = .001 μ F |
| | 2 = 200V | 11 = .01 μ F |
| | 4 = 400V | 01 = .1 μ F |
| | 6 = 600V | 1 = 1.0 μ F |
| | 10 = 1000 V | |
| | 12 = 1200 V | |
| | 16 = 1600 V | |
| | 2X = 2000 V | |

Type PVC Polyester and Polypropylene Film/Foil Capacitors

Notice and Disclaimer: All product drawings, descriptions, specifications, statements, information and data (collectively, the "Information") in this datasheet or other publication are subject to change. The customer is responsible for checking, confirming and verifying the extent to which the Information contained in this datasheet or other publication is applicable to an order at the time the order is placed. All Information given herein is believed to be accurate and reliable, but it is presented without any guarantee, warranty, representation or responsibility of any kind, expressed or implied. Statements of suitability for certain applications are based on the knowledge that the Cornell Dubilier company providing such statements ("Cornell Dubilier") has of operating conditions that such Cornell Dubilier company regards as typical for such applications, but are not intended to constitute any guarantee, warranty or representation regarding any such matter – and Cornell Dubilier specifically and expressly disclaims any guarantee, warranty or representation concerning the suitability for a specific customer application, use, storage, transportation, or operating environment. The Information is intended for use only by customers who have the requisite experience and capability to determine the correct products for their application. Any technical advice inferred from this Information or otherwise provided by Cornell Dubilier with reference to the use of any Cornell Dubilier products is given gratis (unless otherwise specified by Cornell Dubilier), and Cornell Dubilier assumes no obligation or liability for the advice given or results obtained. Although Cornell Dubilier strives to apply the most stringent quality and safety standards regarding the design and manufacturing of its products, in light of the current state of the art, isolated component failures may still occur. Accordingly, customer applications which require a high degree of reliability or safety should employ suitable designs or other safeguards (such as installation of protective circuitry or redundancies or other appropriate protective measures) in order to ensure that the failure of an electrical component does not result in a risk of personal injury or property damage. Although all product-related warnings, cautions and notes must be observed, the customer should not assume that all safety measures are indicated in such warnings, cautions and notes, or that other safety measures may not be required.

Obsolete
See 418P or 715P

OUR CERTIFICATE

DiGi provide top-quality products and perfect service for customer worldwide through standardization, technological innovation and continuous improvement. DiGi through third-party certification, we strictly control the quality of products and services. Welcome your RFQ to

Email: Info@DiGi-Electronics.com



Tel: +00 852-30501935

RFQ Email: Info@DiGi-Electronics.com

DiGi is a global authorized distributor of electronic components.