

CY14B108N-ZSP25XIT Datasheet

www.digi-electronics.com

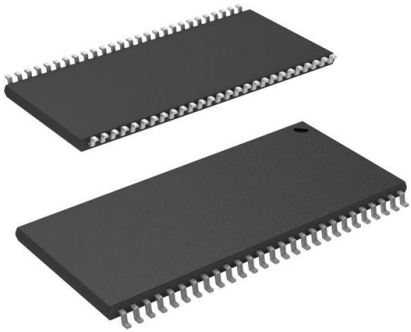

<https://www.DiGi-Electronics.com>

DiGi Electronics Part Number	CY14B108N-ZSP25XIT-DG
Manufacturer	Infineon Technologies
Manufacturer Product Number	CY14B108N-ZSP25XIT
Description	IC NVSRAM 8MBIT PAR 54TSOP II
Detailed Description	NVSRAM (Non-Volatile SRAM) Memory IC 8Mbit Parallel 25 ns 54-TSOP II

This model CY14B108N-ZSP25XIT is available at DiGi Electronics.

DiGi Electronics offers a global database of semiconductor and electronic component datasheets.

We welcome your inquiries regarding pricing, lead time, or other product-related questions.

 [Request a Quote](#)

 [Datasheet Search](#)



Tel: +00 852-30501935

RFQ Email: Info@DiGi-Electronics.com

DiGi is a global authorized distributor of electronic components.

Purchase and inquiry

Manufacturer Product Number:

CY14B108N-ZSP25XIT

Series:

-

DiGi-Electronics Programmable:

Not Verified

Memory Format:

NVSRAM

Memory Size:

8Mbit

Memory Interface:

Parallel

Access Time:

25 ns

Operating Temperature:

-40°C ~ 85°C (TA)

Package / Case:

54-TSOP (0.400", 10.16mm Width)

Base Product Number:

CY14B108

Manufacturer:

Infineon Technologies

Product Status:

Active

Memory Type:

Non-Volatile

Technology:

NVSRAM (Non-Volatile SRAM)

Memory Organization:

512K x 16

Write Cycle Time - Word, Page:

25ns

Voltage - Supply:

2.7V ~ 3.6V

Mounting Type:

Surface Mount

Supplier Device Package:

54-TSOP II

Environmental & Export classification

RoHS Status:

ROHS3 Compliant

REACH Status:

REACH Unaffected

HTSUS:

8542.32.0041

Moisture Sensitivity Level (MSL):

3 (168 Hours)

ECCN:

3A991B2A



CY14B108L
CY14B108N

8-Mbit (1024 K × 8/512 K × 16) nvSRAM

Features

- 20 ns, 25 ns, and 45 ns access times
- Internally organized as 1024 K × 8 (CY14B108L) or 512 K × 16 (CY14B108N)
- Hands off automatic STORE on power-down with only a small capacitor
- STORE to QuantumTrap nonvolatile elements initiated by software, device pin, or AutoStore on power-down
- RECALL to SRAM initiated by software or power-up
- Infinite Read, Write, and RECALL cycles
- 1 million STORE cycles to QuantumTrap
- 20 year data retention
- Single 3 V +20%, -10% operation
- Industrial temperature

Packages

- 44-/54-pin thin small outline package (TSOP) Type II
- 48-ball fine-pitch ball grid array (FBGA)

Pb-free and restriction of hazardous substances (RoHS) compliant

Functional Description

The Cypress CY14B108L/CY14B108N is a fast static RAM (SRAM), with a nonvolatile element in each memory cell. The memory is organized as 1024 Kbytes of 8 bits each or 512 K words of 16 bits each. The embedded nonvolatile elements incorporate QuantumTrap technology, producing the world's most reliable nonvolatile memory. The SRAM provides infinite read and write cycles, while independent nonvolatile data resides in the highly reliable QuantumTrap cell. Data transfers from the SRAM to the nonvolatile elements (the STORE operation) takes place automatically at power-down. On power-up, data is restored to the SRAM (the RECALL operation) from the nonvolatile memory. Both the STORE and RECALL operations are also available under software control.

For a complete list of related documentation, click [here](#).

Logic Block Diagram [1, 2, 3]

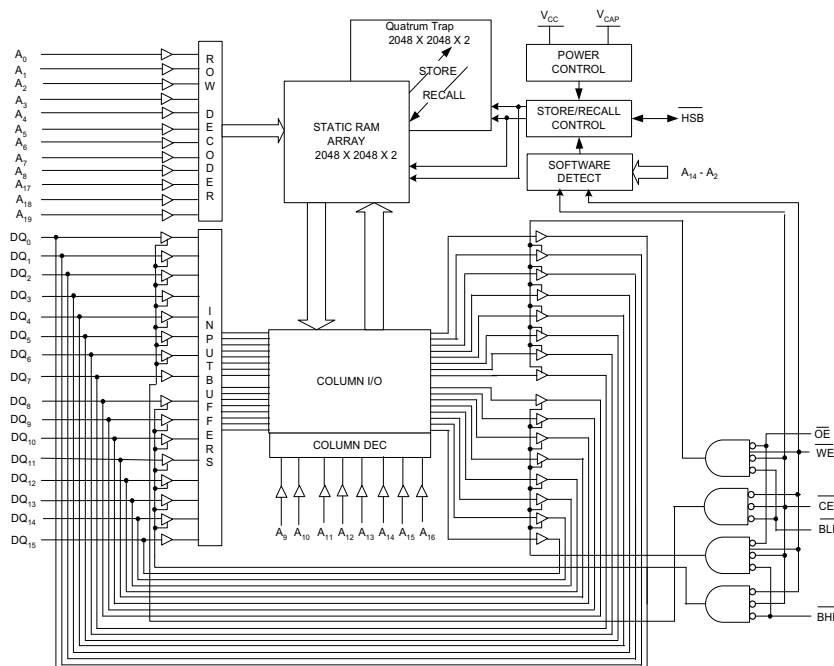

Errata: AutoStore Disable feature does not work in the device. For more information, see [Errata on page 24](#). Details include errata trigger conditions, scope of impact, available workarounds, and silicon revision applicability.

Notes

1. Address A₀-A₁₉ for × 8 configuration and Address A₀-A₁₈ for × 16 configuration.
2. Data DQ₀-DQ₇ for × 8 configuration and Data DQ₀-DQ₁₅ for × 16 configuration.
3. BHE and BLE are applicable for × 16 configuration only.



Contents

Pinouts	3	Software Controlled STORE/RECALL Cycle	16
Pin Definitions	4	Switching Waveforms	16
Device Operation	5	Hardware STORE Cycle	17
SRAM Read	5	Switching Waveforms	17
SRAM Write	5	Truth Table For SRAM Operations	18
AutoStore Operation	5	Ordering Information	19
Hardware STORE Operation	5	Ordering Code Definitions	19
Hardware RECALL (Power-Up)	6	Package Diagrams	20
Software STORE	6	Acronyms	23
Software RECALL	6	Document Conventions	23
Preventing AutoStore	8	Units of Measure	23
Data Protection	8	Errata	24
Maximum Ratings	9	Part Numbers Affected	24
Operating Range	9	8Mb (1024 K × 8, 512 K × 16) nvSRAM	
DC Electrical Characteristics	9	Qualification Status	24
Data Retention and Endurance	10	8Mb (1024 K × 8, 512 K × 16) nvSRAM	
Capacitance	10	Errata Summary	24
Thermal Resistance	10	Document History Page	25
AC Test Loads	11	Sales, Solutions, and Legal Information	27
AC Test Conditions	11	Worldwide Sales and Design Support	27
AC Switching Characteristics	12	Products	27
Switching Waveforms	12	PSoC® Solutions	27
AutoStore/Power-Up RECALL	15	Cypress Developer Community	27
Switching Waveforms	15	Technical Support	27



Pinouts

Figure 1. Pin Diagram – 48-ball FBGA

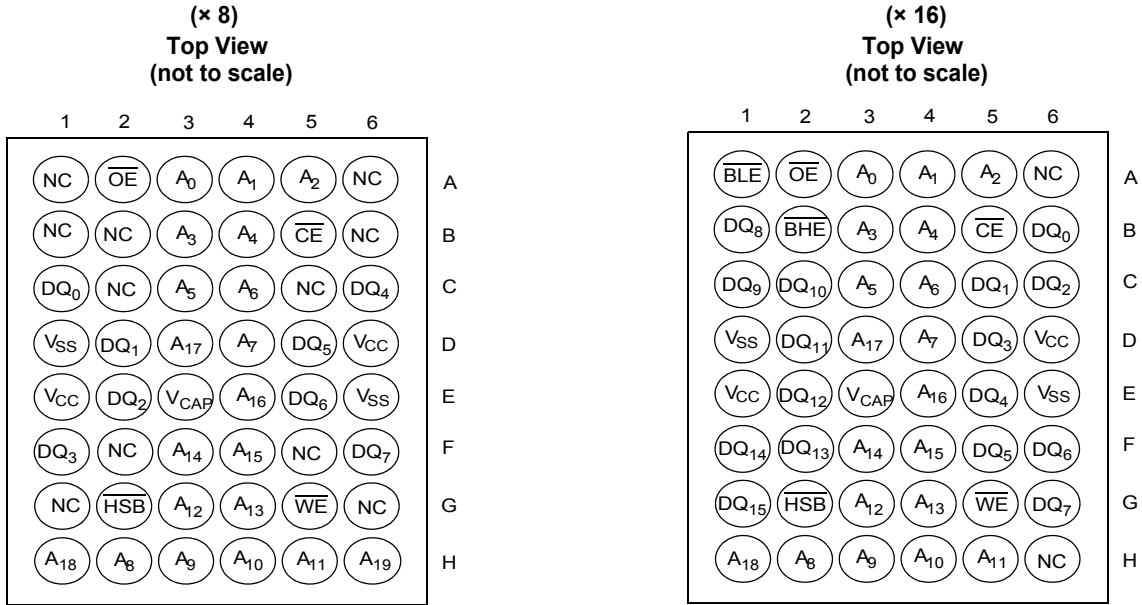
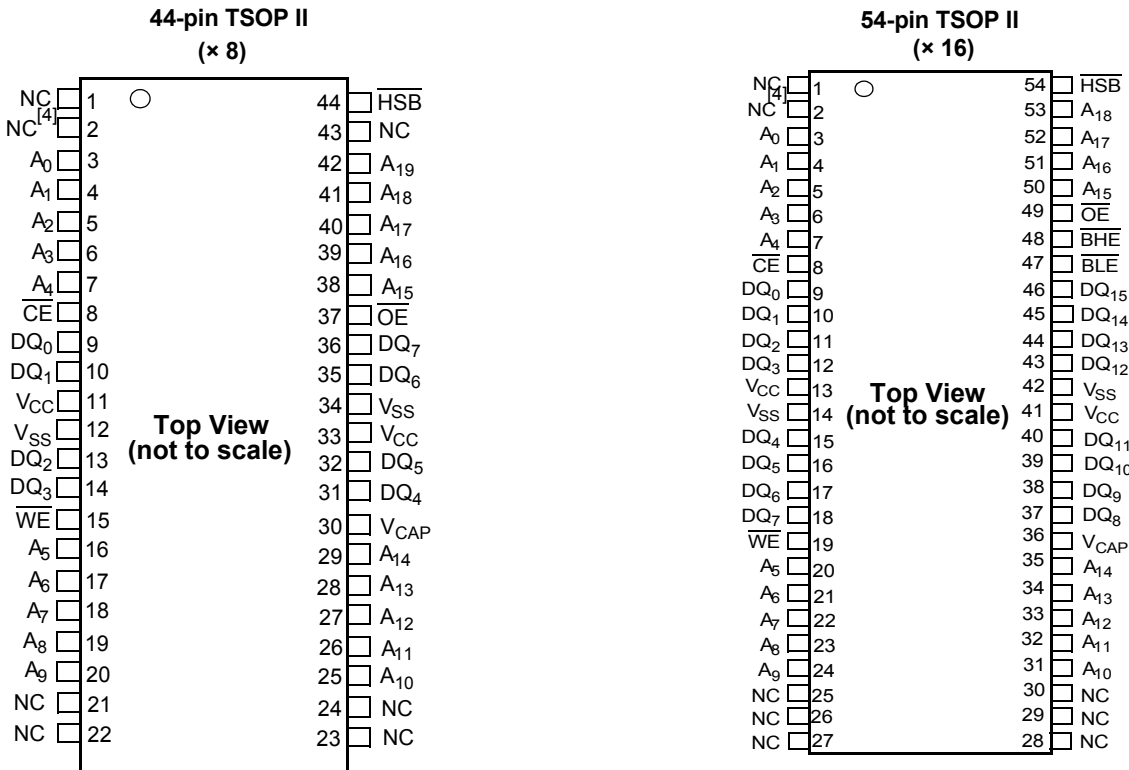

Figure 2. Pin Diagram – 44/54-pin TSOP II



Note
4. Address expansion for 16-Mbit. NC pin not connected to die.



Pin Definitions

Pin Name	I/O Type	Description
A ₀ -A ₁₉	Input	Address inputs. Used to select one of the 1,048,576 bytes of the nvSRAM for × 8 configuration.
A ₀ -A ₁₈		Address inputs. Used to select one of the 524,288 words of the nvSRAM for × 16 configuration.
DQ ₀ -DQ ₇	Input/Output	Bidirectional data I/O lines for × 8 configuration. Used as input or output lines depending on operation.
DQ ₀ -DQ ₁₅		Bidirectional data I/O lines for × 16 configuration. Used as input or output lines depending on operation.
$\overline{\text{WE}}$	Input	Write Enable input, Active LOW. When selected LOW, data on the I/O pins is written to the specific address location.
$\overline{\text{CE}}$	Input	Chip Enable input, Active LOW. When LOW, selects the chip. When HIGH, deselects the chip.
$\overline{\text{OE}}$	Input	Output Enable, Active LOW. The active LOW $\overline{\text{OE}}$ input enables the data output buffers during read cycles. I/O pins are tristated on deasserting $\overline{\text{OE}}$ HIGH.
$\overline{\text{BHE}}$	Input	Byte High Enable, Active LOW. Controls DQ ₁₅ -DQ ₈ .
$\overline{\text{BLE}}$	Input	Byte Low Enable, Active LOW. Controls DQ ₇ -DQ ₀ .
V _{SS}	Ground	Ground for the device. Must be connected to the ground of the system.
V _{CC}	Power supply	Power supply inputs to the device.
$\overline{\text{HSB}}$	Input/Output	Hardware STORE Busy ($\overline{\text{HSB}}$). When LOW this output indicates that a Hardware STORE is in progress. When pulled LOW external to the chip it initiates a nonvolatile STORE operation. After each Hardware and Software STORE operation, HSB is driven HIGH for a short time (t _{HHD}) with standard output high current and then a weak internal pull-up resistor keeps this pin HIGH (external pull-up resistor connection optional).
V _{CAP}	Power supply	AutoStore capacitor. Supplies power to the nvSRAM during power loss to store data from SRAM to nonvolatile elements.
NC	No connect	No connect. This pin is not connected to the die.

Device Operation

The CY14B108L/CY14B108N nvSRAM is made up of two functional components paired in the same physical cell. They are a SRAM memory cell and a nonvolatile QuantumTrap cell. The SRAM memory cell operates as a standard fast static RAM. Data in the SRAM is transferred to the nonvolatile cell (the STORE operation), or from the nonvolatile cell to the SRAM (the RECALL operation). Using this unique architecture, all cells are stored and recalled in parallel. During the STORE and RECALL operations, SRAM read and write operations are inhibited. The CY14B108L/CY14B108N supports infinite reads and writes similar to a typical SRAM. In addition, it provides infinite RECALL operations from the nonvolatile cells and up to 1 million STORE operations. See [Truth Table For SRAM Operations on page 18](#) for a complete description of read and write modes.

SRAM Read

The CY14B108L/CY14B108N performs a read cycle when \overline{CE} and \overline{OE} are LOW and \overline{WE} and HSB are HIGH. The address specified on pins A_{0-19} or A_{0-18} determines which of the 1,048,576 data bytes or 524,288 words of 16 bits each are accessed. Byte enables (\overline{BHE} , \overline{BLE}) determine which bytes are enabled to the output, in the case of 16-bit words. When the read is initiated by an address transition, the outputs are valid after a delay of t_{AA} (read cycle 1). If the read is initiated by \overline{CE} or \overline{OE} , the outputs are valid at t_{ACE} or at t_{DOE} , whichever is later (read cycle 2). The data output repeatedly responds to address changes within the t_{AA} access time without the need for transitions on any control input pins. This remains valid until another address change or until \overline{CE} or \overline{OE} is brought HIGH, or \overline{WE} or HSB is brought LOW.

SRAM Write

A write cycle is performed when \overline{CE} and \overline{WE} are LOW and HSB is HIGH. The address inputs must be stable before entering the write cycle and must remain stable until \overline{CE} or \overline{WE} goes HIGH at the end of the cycle. The data on the common I/O pins DQ_{0-15} are written into the memory if the data is valid t_{SD} before the end of a \overline{WE} controlled write or before the end of an \overline{CE} controlled write. The Byte Enable inputs (\overline{BHE} , \overline{BLE}) determine which bytes are written, in the case of 16-bit words. Keep \overline{OE} HIGH during the entire write cycle to avoid data bus contention on common I/O lines. If \overline{OE} is left LOW, internal circuitry turns off the output buffers t_{HZWE} after \overline{WE} goes LOW.

AutoStore Operation

The CY14B108L/CY14B108N stores data to the nvSRAM using one of the following three storage operations: Hardware STORE activated by the HSB; Software STORE activated by an address sequence; AutoStore on device power-down. The AutoStore operation is a unique feature of QuantumTrap technology and is enabled by default on the CY14B108L/CY14B108N.

During a normal operation, the device draws current from V_{CC} to charge a capacitor connected to the V_{CAP} pin. This stored charge is used by the chip to perform a single STORE operation. If the voltage on the V_{CC} pin drops below V_{SWITCH} , the part automatically disconnects the V_{CAP} pin from V_{CC} . A STORE operation is initiated with power provided by the V_{CAP} capacitor.

Note If the capacitor is not connected to V_{CAP} pin, AutoStore must be disabled using the soft sequence specified in [Preventing](#)

[AutoStore on page 8](#). In case AutoStore is enabled without a capacitor on V_{CAP} pin, the device attempts an AutoStore operation without sufficient charge to complete the Store. This corrupts the data stored in nvSRAM.

[Figure 3](#) shows the proper connection of the storage capacitor (V_{CAP}) for automatic STORE operation. Refer to [DC Electrical Characteristics on page 9](#) for the size of V_{CAP} . The voltage on the V_{CAP} pin is driven to V_{CC} by a regulator on the chip. A pull-up should be placed on \overline{WE} to hold it inactive during power-up. This pull-up is effective only if the \overline{WE} signal is tristate during power-up. Many MPUs tristate their controls on power-up. This should be verified when using the pull-up. When the nvSRAM comes out of power-on-RECALL, the MPU must be active or the \overline{WE} held inactive until the MPU comes out of reset.

To reduce unnecessary nonvolatile STOREs, AutoStore and Hardware STORE operations are ignored unless at least one write operation has taken place since the most recent STORE or RECALL cycle. Software initiated STORE cycles are performed regardless of whether a write operation has taken place. The HSB signal is monitored by the system to detect if an AutoStore cycle is in progress.

Figure 3. AutoStore Mode

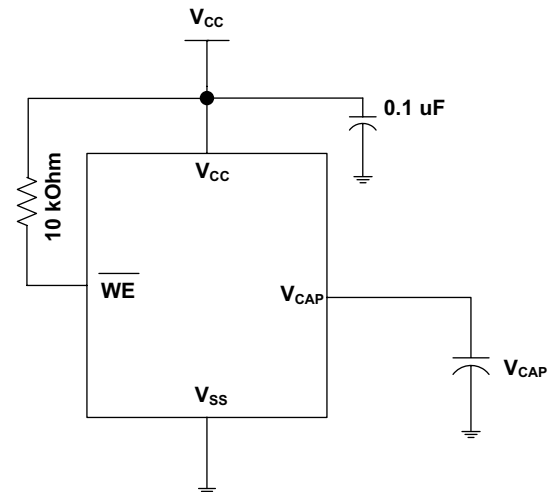

Hardware STORE Operation

The CY14B108L/CY14B108N provides the \overline{HSB} pin to control and acknowledge the STORE operations. Use the \overline{HSB} pin to request a Hardware STORE cycle. When the \overline{HSB} pin is driven LOW, the CY14B108L/CY14B108N conditionally initiates a STORE operation after t_{DELAY} . An actual STORE cycle only begins if a write to the SRAM has taken place since the last STORE or RECALL cycle. The \overline{HSB} pin also acts as an open drain driver (internal 100 k Ω weak pull-up resistor) that is internally driven LOW to indicate a busy condition when the STORE (initiated by any means) is in progress.

Note After each Hardware and Software STORE operation \overline{HSB} is driven HIGH for a short time (t_{HHHD}) with standard output high current and then remains HIGH by internal 100 k Ω pull-up resistor.



SRAM write operations that are in progress when $\overline{\text{HSB}}$ is driven LOW by any means are given time (t_{DELAY}) to complete before the STORE operation is initiated. However, any SRAM write cycles requested after $\overline{\text{HSB}}$ goes LOW are inhibited until $\overline{\text{HSB}}$ returns HIGH. In case the write latch is not set, $\overline{\text{HSB}}$ is not driven LOW by the CY14B108L/CY14B108N. But any SRAM read and write cycles are inhibited until $\overline{\text{HSB}}$ is returned HIGH by MPU or other external source.

During any STORE operation, regardless of how it is initiated, the CY14B108L/CY14B108N continues to drive the $\overline{\text{HSB}}$ pin LOW, releasing it only when the STORE is complete. Upon completion of the STORE operation, the nvSRAM memory access is inhibited for t_{LZHSB} time after $\overline{\text{HSB}}$ pin returns HIGH. Leave the $\overline{\text{HSB}}$ unconnected if it is not used.

Hardware RECALL (Power-Up)

During power-up or after any low power condition ($V_{\text{CC}} < V_{\text{SWITCH}}$), an internal RECALL request is latched. When V_{CC} again exceeds the V_{SWITCH} on power-up, a RECALL cycle is automatically initiated and takes t_{HRECALL} to complete. During this time, the $\overline{\text{HSB}}$ pin is driven LOW by the $\overline{\text{HSB}}$ driver and all reads and writes to nvSRAM are inhibited.

Software STORE

Data is transferred from the SRAM to the nonvolatile memory by a software address sequence. The CY14B108L/CY14B108N Software STORE cycle is initiated by executing sequential $\overline{\text{CE}}$ or $\overline{\text{OE}}$ controlled read cycles from six specific address locations in exact order. During the STORE cycle an erase of the previous nonvolatile data is first performed, followed by a program of the nonvolatile elements. After a STORE cycle is initiated, further input and output are disabled until the cycle is completed.

Because a sequence of READs from specific addresses is used for STORE initiation, it is important that no other read or write accesses intervene in the sequence, or the sequence is aborted and no STORE or RECALL takes place.

To initiate the Software STORE cycle, the following read sequence must be performed.

1. Read address 0x4E38 Valid READ
2. Read address 0xB1C7 Valid READ
3. Read address 0x83E0 Valid READ
4. Read address 0x7C1F Valid READ
5. Read address 0x703F Valid READ
6. Read address 0x8FC0 Initiate STORE cycle

The software sequence may be clocked with $\overline{\text{CE}}$ controlled reads or $\overline{\text{OE}}$ controlled reads, with $\overline{\text{WE}}$ kept HIGH for all the six READ sequences. After the sixth address in the sequence is entered, the STORE cycle commences and the chip is disabled. $\overline{\text{HSB}}$ is driven LOW. After the t_{STORE} cycle time is fulfilled, the SRAM is activated again for the read and write operation.

Software RECALL

Data is transferred from the nonvolatile memory to the SRAM by a software address sequence. A software RECALL cycle is initiated with a sequence of read operations in a manner similar to the software STORE initiation. To initiate the RECALL cycle, the following sequence of $\overline{\text{CE}}$ or $\overline{\text{OE}}$ controlled read operations must be performed.

1. Read address 0x4E38 Valid READ
2. Read address 0xB1C7 Valid READ
3. Read address 0x83E0 Valid READ
4. Read address 0x7C1F Valid READ
5. Read address 0x703F Valid READ
6. Read address 0x4C63 Initiate RECALL cycle

Internally, RECALL is a two-step procedure. First, the SRAM data is cleared; then, the nonvolatile information is transferred into the SRAM cells. After the t_{RECALL} cycle time, the SRAM is again ready for read and write operations. The RECALL operation does not alter the data in the nonvolatile elements.



Table 1. Mode Selection

$\overline{\text{CE}}$	$\overline{\text{WE}}$	$\overline{\text{OE}}$	$\overline{\text{BHE}}, \overline{\text{BLE}}^{[5]}$	$\text{A}_{15}\text{-A}_0^{[6]}$	Mode	I/O	Power
H	X	X	X	X	Not Selected	Output High Z	Standby
L	H	L	L	X	Read SRAM	Output data	Active
L	L	X	L	X	Write SRAM	Input data	Active
L	H	L	X	0x4E38 0xB1C7 0x83E0 0x7C1F 0x703F 0x8B45	Read SRAM Read SRAM Read SRAM Read SRAM Read SRAM AutoStore Disable	Output data Output data Output data Output data Output data Output data	Active ^[7]
L	H	L	X	0x4E38 0xB1C7 0x83E0 0x7C1F 0x703F 0x4B46	Read SRAM Read SRAM Read SRAM Read SRAM Read SRAM AutoStore Enable	Output data Output data Output data Output data Output data Output data	Active ^[7]
L	H	L	X	0x4E38 0xB1C7 0x83E0 0x7C1F 0x703F 0x8FC0	Read SRAM Read SRAM Read SRAM Read SRAM Read SRAM Nonvolatile STORE	Output data Output data Output data Output data Output data Output High Z	Active I _{CC2} ^[7]
L	H	L	X	0x4E38 0xB1C7 0x83E0 0x7C1F 0x703F 0x4C63	Read SRAM Read SRAM Read SRAM Read SRAM Read SRAM Nonvolatile RECALL	Output data Output data Output data Output data Output data Output High Z	Active ^[7]

Errata: AutoStore Disable feature does not work in the device. For more information, see [Errata on page 24](#).

Notes

- BHE and BLE are applicable for × 16 configuration only.
- While there are 20 address lines on the CY14B108L (19 address lines on the CY14B108N), only the 13 address lines (A₁₄–A₂) are used to control software modes. Rest of the address lines are don't care.
- The six consecutive address locations must be in the order listed. $\overline{\text{WE}}$ must be HIGH during all six cycles to enable a nonvolatile cycle.



Preventing AutoStore

The AutoStore function is disabled by initiating an AutoStore disable sequence. A sequence of read operations is performed in a manner similar to the Software STORE initiation. To initiate the AutoStore disable sequence, the following sequence of \overline{CE} or \overline{OE} controlled read operations must be performed:

1. Read address 0x4E38 Valid READ
2. Read address 0xB1C7 Valid READ
3. Read address 0x83E0 Valid READ
4. Read address 0x7C1F Valid READ
5. Read address 0x703F Valid READ
6. Read address 0x8B45 AutoStore Disable

Note Errata: AutoStore Disable feature does not work in the device. For more information, see [Errata on page 24](#).

The AutoStore is re-enabled by initiating an AutoStore enable sequence. A sequence of read operations is performed in a manner similar to the Software RECALL initiation. To initiate the

AutoStore enable sequence, the following sequence of \overline{CE} or \overline{OE} controlled read operations must be performed:

1. Read address 0x4E38 Valid READ
2. Read address 0xB1C7 Valid READ
3. Read address 0x83E0 Valid READ
4. Read address 0x7C1F Valid READ
5. Read address 0x703F Valid READ
6. Read address 0x4B46 AutoStore Enable

If the AutoStore function is disabled or re-enabled, a manual STORE operation (Hardware or Software) must be issued to save the AutoStore state through subsequent power-down cycles. The part comes from the factory with AutoStore enabled and 0x00 written in all cells.

Data Protection

The CY14B108L/CY14B108N protects data from corruption during low voltage conditions by inhibiting all externally initiated STORE and write operations. The low voltage condition is detected when $V_{CC} < V_{SWITCH}$. If the CY14B108L/CY14B108N is in a write mode (both \overline{CE} and \overline{WE} are LOW) at power-up, after a RECALL or STORE, the write is inhibited until the SRAM is enabled after t_{LZHSB} (HSB to output active). This protects against inadvertent writes during power-up or brown out conditions.



Maximum Ratings

Exceeding maximum ratings may impair the useful life of the device. These user guidelines are not tested.

Storage temperature	-65 °C to +150 °C
Maximum accumulated storage time	
At 150 °C ambient temperature	1000 h
At 85 °C ambient temperature	20 Years
Maximum junction temperature	150 °C
Supply voltage on V_{CC} relative to V_{SS}	-0.5 V to 4.1 V
Voltage applied to outputs in High Z state	-0.5 V to $V_{CC} + 0.5$ V
Input voltage	-0.5 V to $V_{CC} + 0.5$ V

Transient voltage (< 20 ns) on any pin to ground potential	-2.0 V to $V_{CC} + 2.0$ V
Package power dissipation capability ($T_A = 25$ °C)	1.0 W
Surface mount Pb soldering temperature (3 Seconds)	+260 °C
DC output current (1 output at a time, 1s duration)	15 mA
Static discharge voltage (per MIL-STD-883, Method 3015)	> 2001 V
Latch up current	> 200 mA

Operating Range

Range	Ambient Temperature	V_{CC}
Industrial	-40 °C to +85 °C	2.7 V to 3.6 V

DC Electrical Characteristics

Over the [Operating Range](#)

Parameter	Description	Test Conditions	Min	Typ ^[8]	Max	Unit
V_{CC}	Power supply		2.7	3.0	3.6	V
I_{CC1}	Average V_{CC} current	$t_{RC} = 20$ ns $t_{RC} = 25$ ns $t_{RC} = 45$ ns Values obtained without output loads ($I_{OUT} = 0$ mA)	-	-	75 75 57	mA mA mA
I_{CC2}	Average V_{CC} current during STORE	All inputs don't care, $V_{CC} = \text{Max}$ Average current for duration t_{STORE}	-	-	20	mA
I_{CC3}	Average V_{CC} current at $t_{RC} = 200$ ns, $V_{CC(Typ)}$, 25 °C	All inputs cycling at CMOS levels. Values obtained without output loads ($I_{OUT} = 0$ mA).	-	40	-	mA
I_{CC4}	Average V_{CAP} current during AutoStore cycle	All inputs don't care. Average current for duration t_{STORE}	-	-	10	mA
I_{SB}	V_{CC} standby current	$CE \geq (V_{CC} - 0.2$ V). $V_{IN} \leq 0.2$ V or $\geq (V_{CC} - 0.2$ V). Standby current level after nonvolatile cycle is complete. Inputs are static. $f = 0$ MHz.	-	-	10	mA
$I_{IX}^{[9]}$	Input leakage current (except HSB)	$V_{CC} = \text{Max}$, $V_{SS} \leq V_{IN} \leq V_{CC}$	-2	-	+2	μ A
	Input leakage current (for HSB)	$V_{CC} = \text{Max}$, $V_{SS} \leq V_{IN} \leq V_{CC}$	-200	-	+2	μ A
I_{OZ}	Off-state output leakage current	$V_{CC} = \text{Max}$, $V_{SS} \leq V_{OUT} \leq V_{CC}$, CE or $OE \geq V_{IH}$ or $BHE/BLE \geq V_{IH}$ or $WE \leq V_{IL}$	-2	-	+2	μ A
V_{IH}	Input HIGH voltage		2.0	-	$V_{CC} + 0.5$	V
V_{IL}	Input LOW voltage		$V_{SS} - 0.5$	-	0.8	V
V_{OH}	Output HIGH voltage	$I_{OUT} = -2$ mA	2.4	-	-	V
V_{OL}	Output LOW voltage	$I_{OUT} = 4$ mA	-	-	0.4	V

Notes

8. Typical values are at 25 °C, $V_{CC} = V_{CC(Typ)}$. Not 100% tested.

9. The HSB pin has $I_{OUT} = -2$ μ A for V_{OH} of 2.4 V when both active HIGH and LOW drivers are disabled. When they are enabled standard V_{OH} and V_{OL} are valid. This parameter is characterized but not tested.



DC Electrical Characteristics (continued)

Over the [Operating Range](#)

Parameter	Description	Test Conditions	Min	Typ ^[8]	Max	Unit
$V_{CAP}^{[10]}$	Storage capacitor	Between V_{CAP} pin and V_{SS}	122	150	360	μF
$V_{VCAP}^{[11, 12]}$	Maximum voltage driven on V_{CAP} pin by the device	$V_{CC} = \text{Max}$	–	–	V_{CC}	V

Data Retention and Endurance

Over the [Operating Range](#)

Parameter	Description	Min	Unit
DATA_R	Data retention	20	Years
NV_C	Nonvolatile STORE operations	1,000	K

Capacitance

Parameter ^[12]	Description	Test Conditions	Max	Unit
C_{IN}	Input capacitance	$T_A = 25\text{ }^\circ\text{C}$, $f = 1\text{ MHz}$, $V_{CC} = V_{CC(\text{Typ})}$	14	pF
C_{OUT}	Output capacitance		14	pF

Thermal Resistance

Parameter ^[12]	Description	Test Conditions	48-ball FBGA	44-pin TSOP II	54-pin TSOP II	Unit
Θ_{JA}	Thermal resistance (Junction to ambient)	Test conditions follow standard test methods and procedures for measuring thermal impedance, in accordance with EIA/JESD51.	42.2	45.3	44.22	$^\circ\text{C/W}$
Θ_{JC}	Thermal resistance (Junction to case)		6.3	5.2	8.26	$^\circ\text{C/W}$

Notes

- Min V_{CAP} value guarantees that there is a sufficient charge available to complete a successful AutoStore operation. Max V_{CAP} value guarantees that the capacitor on V_{CAP} is charged to a minimum voltage during a Power-Up RECALL cycle so that an immediate power-down cycle can complete a successful AutoStore. Therefore it is always recommended to use a capacitor within the specified min and max limits. Refer application note [AN43593](#) for more details on V_{CAP} options.
- Maximum voltage on V_{CAP} pin (V_{VCAP}) is provided for guidance when choosing the V_{CAP} capacitor. The voltage rating of the V_{CAP} capacitor across the operating temperature range should be higher than the V_{VCAP} voltage.
- These parameters are guaranteed by design and are not tested.



AC Test Loads

Figure 4. AC Test Loads

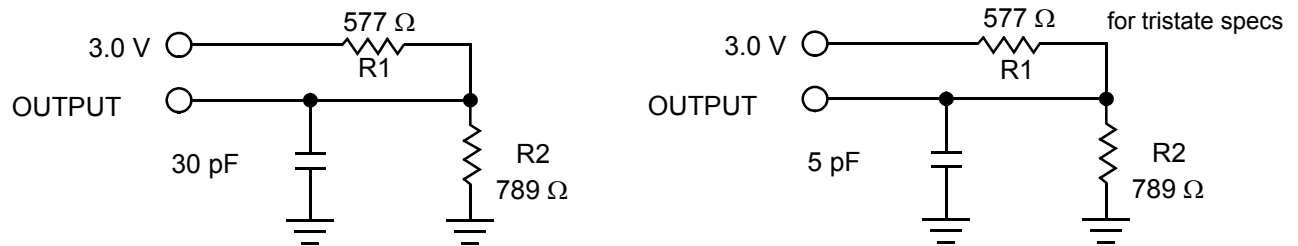

AC Test Conditions

Input pulse levels 0 V to 3 V
 Input rise and fall times (10%–90%) ≤ 3 ns
 Input and output timing reference levels 1.5 V



AC Switching Characteristics

Over the [Operating Range](#)

Parameters ^[13]		Description	20 ns		25 ns		45 ns		Unit
Cypress Parameter	Alt Parameter		Min	Max	Min	Max	Min	Max	
SRAM Read Cycle									
t_{ACE}	t_{ACS}	Chip enable access time	–	20	–	25	–	45	ns
$t_{RC}^{[14]}$	t_{RC}	Read cycle time	20	–	25	–	45	–	ns
$t_{AA}^{[15]}$	t_{AA}	Address access time	–	20	–	25	–	45	ns
t_{DOE}	t_{OE}	Output enable to data valid	–	10	–	12	–	20	ns
$t_{OHA}^{[15]}$	t_{OH}	Output hold after address change	3	–	3	–	3	–	ns
$t_{LZCE}^{[16, 17]}$	t_{LZ}	Chip enable to output active	3	–	3	–	3	–	ns
$t_{HZCE}^{[16, 17]}$	t_{HZ}	Chip disable to output inactive	–	8	–	10	–	15	ns
$t_{LZOE}^{[16, 17]}$	t_{OLZ}	Output enable to output active	0	–	0	–	0	–	ns
$t_{HZOE}^{[16, 17]}$	t_{OHZ}	Output disable to output inactive	–	8	–	10	–	15	ns
$t_{PU}^{[16]}$	t_{PA}	Chip enable to power active	0	–	0	–	0	–	ns
$t_{PD}^{[16]}$	t_{PS}	Chip disable to power standby	–	20	–	25	–	45	ns
t_{DBE}	–	Byte enable to data valid	–	10	–	12	–	20	ns
$t_{LZBE}^{[16]}$	–	Byte enable to output active	0	–	0	–	0	–	ns
$t_{HZBE}^{[16]}$	–	Byte disable to output inactive	–	8	–	10	–	15	ns
SRAM Write Cycle									
t_{WC}	t_{WC}	Write cycle time	20	–	25	–	45	–	ns
t_{PWE}	t_{WP}	Write pulse width	15	–	20	–	30	–	ns
t_{SCE}	t_{CW}	Chip enable to end of write	15	–	20	–	30	–	ns
t_{SD}	t_{DW}	Data setup to end of write	8	–	10	–	15	–	ns
t_{HD}	t_{DH}	Data hold after end of write	0	–	0	–	0	–	ns
t_{AW}	t_{AW}	Address setup to end of write	15	–	20	–	30	–	ns
t_{SA}	t_{AS}	Address setup to start of write	0	–	0	–	0	–	ns
t_{HA}	t_{WR}	Address hold after end of write	0	–	0	–	0	–	ns
$t_{HZWE}^{[16, 17, 18]}$	t_{WZ}	Write enable to output disable	–	8	–	10	–	15	ns
$t_{LZWE}^{[16, 17]}$	t_{OW}	Output active after end of write	3	–	3	–	3	–	ns
t_{BW}	–	Byte enable to end of write	15	–	20	–	30	–	ns

Switching Waveforms

Figure 5. SRAM Read Cycle #1 (Address Controlled) ^[14, 15, 19]

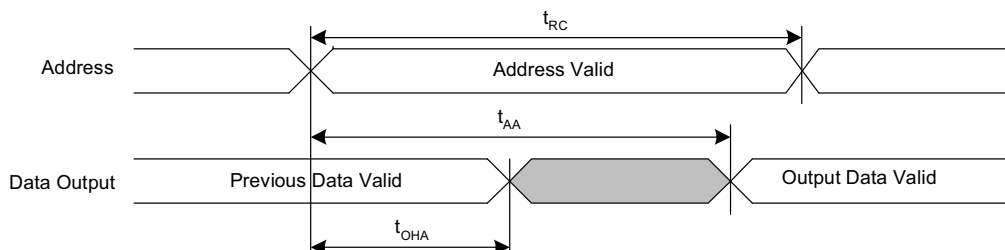

Notes

13. Test conditions assume signal transition time of 3 ns or less, timing reference levels of $V_{CC}/2$, input pulse levels of 0 to $V_{CC(typ)}$, and output loading of the specified I_{OL}/I_{OH} and load capacitance shown in [Figure 4 on page 11](#).
14. WE must be HIGH during SRAM read cycles.
15. Device is continuously selected with CE, OE and BHE / BLE LOW.
16. These parameters are guaranteed by design but not tested.
17. Measured ± 200 mV from steady state output voltage.
18. If WE is LOW when CE goes LOW, the outputs remain in the high impedance state.
19. HSB must remain HIGH during READ and WRITE cycles.

Switching Waveforms (continued)

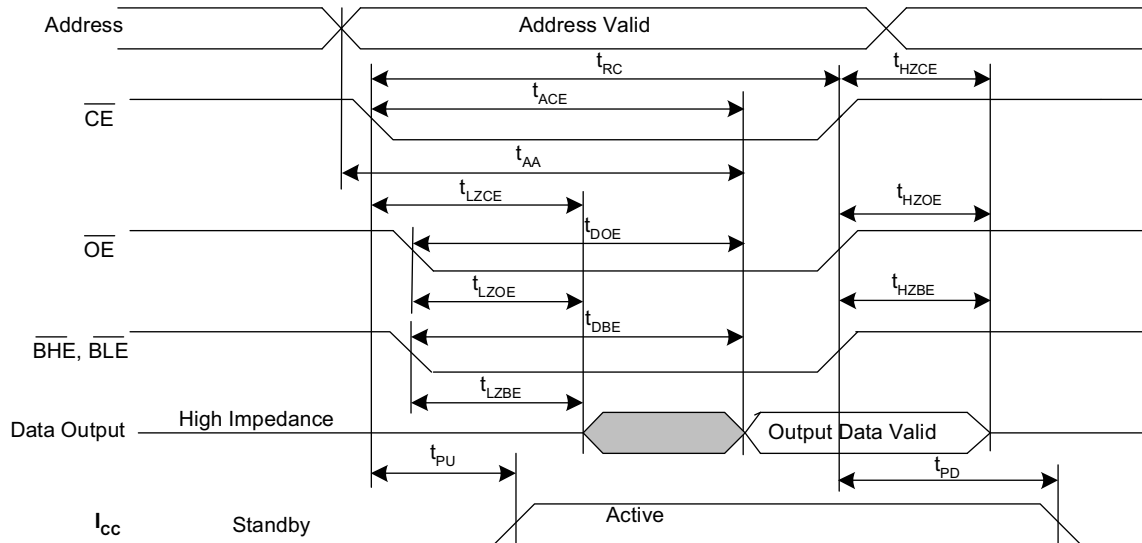
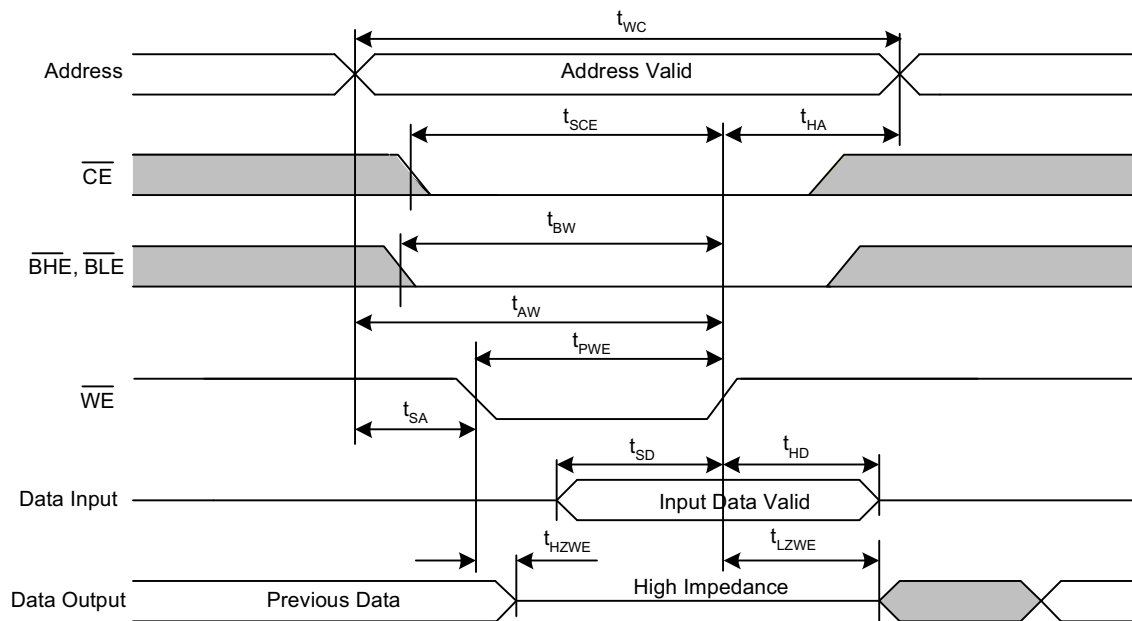
Figure 6. SRAM Read Cycle #2 ($\overline{\text{CE}}$ and $\overline{\text{OE}}$ Controlled) [20, 21, 22]

Figure 7. SRAM Write Cycle #1 ($\overline{\text{WE}}$ Controlled) [20, 22, 23, 24]

Notes

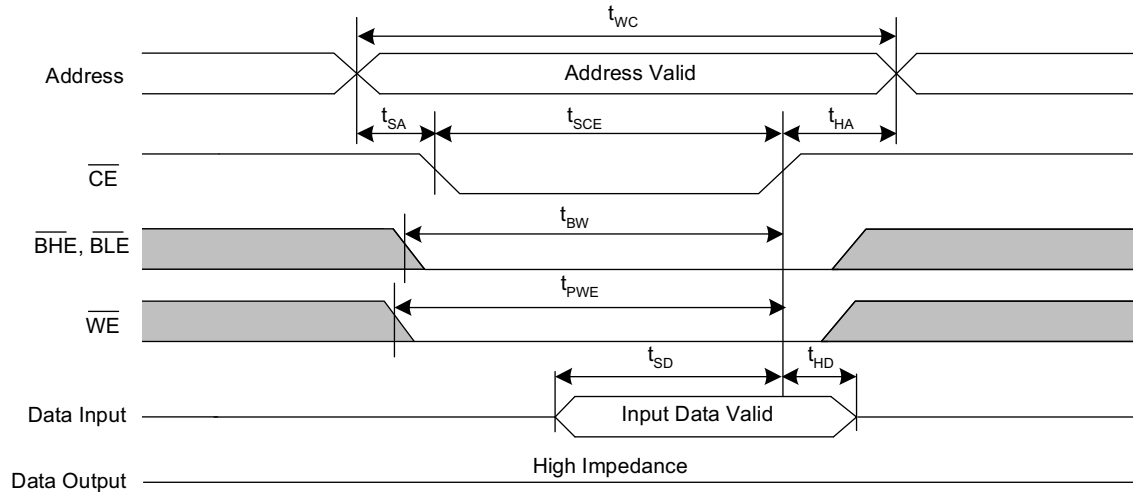
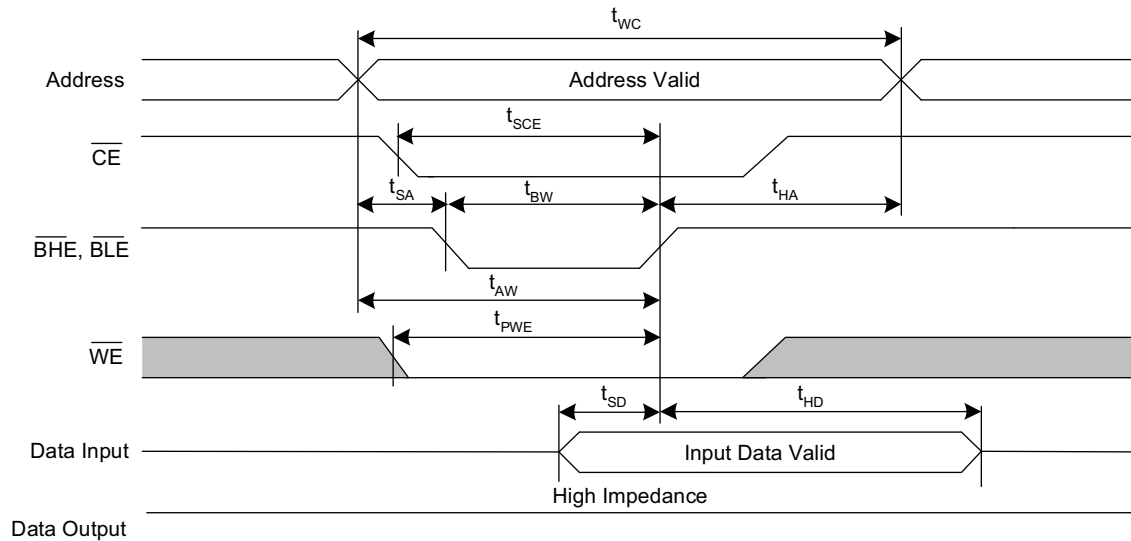
20. $\overline{\text{BHE}}$ and $\overline{\text{BLE}}$ are applicable for $\times 16$ configuration only.
21. $\overline{\text{WE}}$ must be HIGH during SRAM read cycles.
22. $\overline{\text{HSB}}$ must remain HIGH during READ and WRITE cycles.
23. If $\overline{\text{WE}}$ is LOW when $\overline{\text{CE}}$ goes LOW, the outputs remain in the high impedance state.
24. $\overline{\text{CE}}$ or $\overline{\text{WE}}$ must be $\geq V_{\text{IH}}$ during address transitions.

Switching Waveforms (continued)

Figure 8. SRAM Write Cycle #2 ($\overline{\text{CE}}$ Controlled) [25, 26, 27, 28]

Figure 9. SRAM Write Cycle #3 ($\overline{\text{BHE}}$ and $\overline{\text{BLE}}$ Controlled) [25, 26, 27, 28]

Notes

25. $\overline{\text{BHE}}$ and $\overline{\text{BLE}}$ are applicable for $\times 16$ configuration only.
26. If $\overline{\text{WE}}$ is LOW when $\overline{\text{CE}}$ goes LOW, the outputs remain in the high impedance state.
27. $\overline{\text{HSB}}$ must remain HIGH during READ and WRITE cycles.
28. $\overline{\text{CE}}$ or $\overline{\text{WE}}$ must be $\geq V_{\text{IH}}$ during address transitions.

AutoStore/Power-Up RECALL

Over the [Operating Range](#)

Parameter	Description	20 ns		25 ns		45 ns		Unit
		Min	Max	Min	Max	Min	Max	
$t_{HRECALL}^{[29]}$	Power-Up RECALL duration	–	20	–	20	–	20	ms
$t_{STORE}^{[30]}$	STORE cycle duration	–	8	–	8	–	8	ms
$t_{DELAY}^{[31]}$	Time allowed to complete SRAM write cycle	–	20	–	25	–	25	ns
V_{SWITCH}	Low voltage trigger level	–	2.65	–	2.65	–	2.65	V
$t_{VCCRRISE}^{[32]}$	V_{CC} rise time	150	–	150	–	150	–	μ s
$V_{HDIS}^{[32]}$	HSB output disable voltage	–	1.9	–	1.9	–	1.9	V
$t_{LZHSB}^{[32]}$	HSB to output active time	–	5	–	5	–	5	μ s
$t_{HHHD}^{[32]}$	HSB high active time	–	500	–	500	–	500	ns

Switching Waveforms

Figure 10. AutoStore or Power-Up RECALL ^[33]

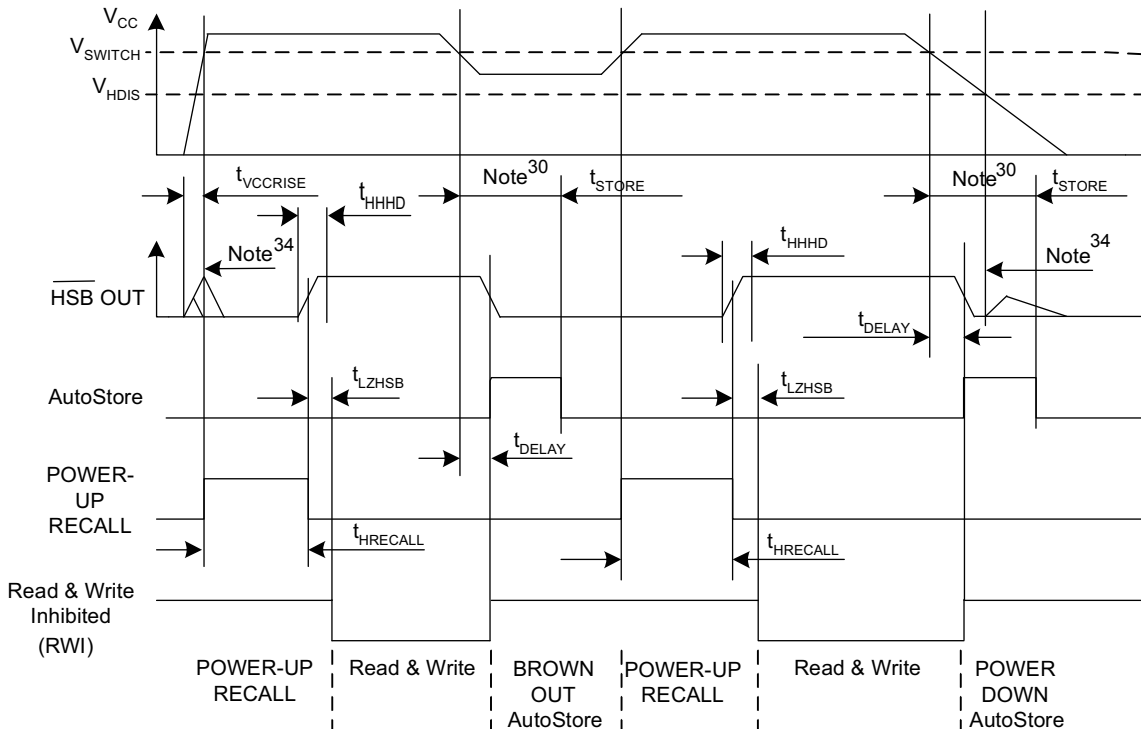

Notes

29. $t_{HRECALL}$ starts from the time V_{CC} rises above V_{SWITCH} .
30. If an SRAM write has not taken place since the last nonvolatile cycle, no AutoStore or Hardware STORE takes place.
31. On a Hardware STORE and AutoStore initiation, SRAM write operation continues to be enabled for time t_{DELAY} .
32. These parameters are guaranteed by design but not tested.
33. Read and Write cycles are ignored during STORE, RECALL, and while V_{CC} is below V_{SWITCH} .
34. During power-up and power-down, HSB glitches when HSB pin is pulled up through an external resistor.

Software Controlled STORE/RECALL Cycle

Over the [Operating Range](#)

Parameter ^[35, 36]	Description	20 ns		25 ns		45 ns		Unit
		Min	Max	Min	Max	Min	Max	
t_{RC}	STORE/RECALL initiation cycle time	20	–	25	–	45	–	ns
t_{SA}	Address setup time	0	–	0	–	0	–	ns
t_{CW}	Clock pulse width	15	–	20	–	30	–	ns
t_{HA}	Address hold time	0	–	0	–	0	–	ns
t_{RECALL}	RECALL duration	–	200	–	200	–	200	μs

Switching Waveforms

Figure 11. \overline{CE} and \overline{OE} Controlled Software STORE/RECALL Cycle ^[36]

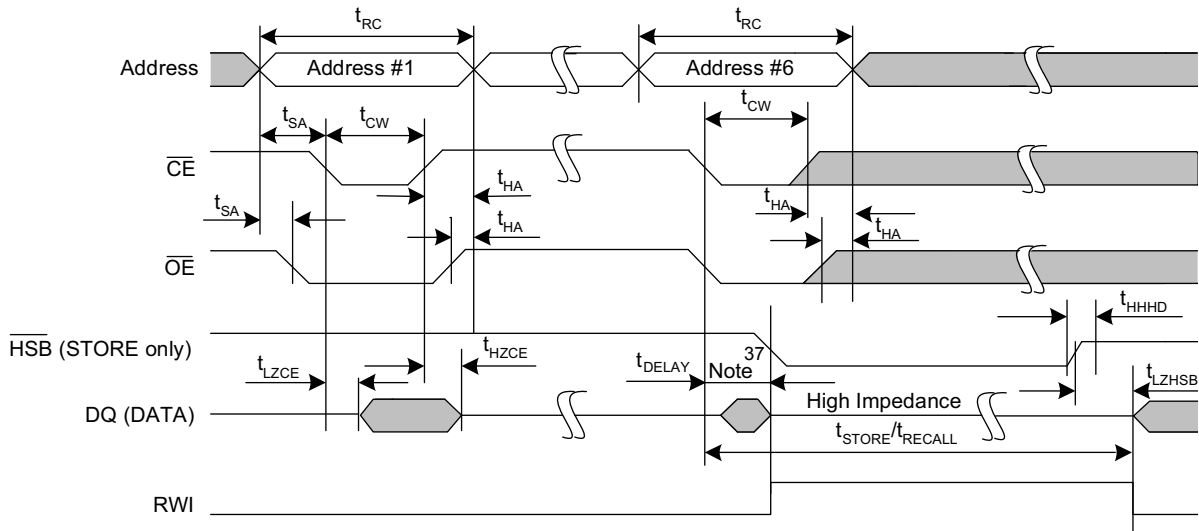
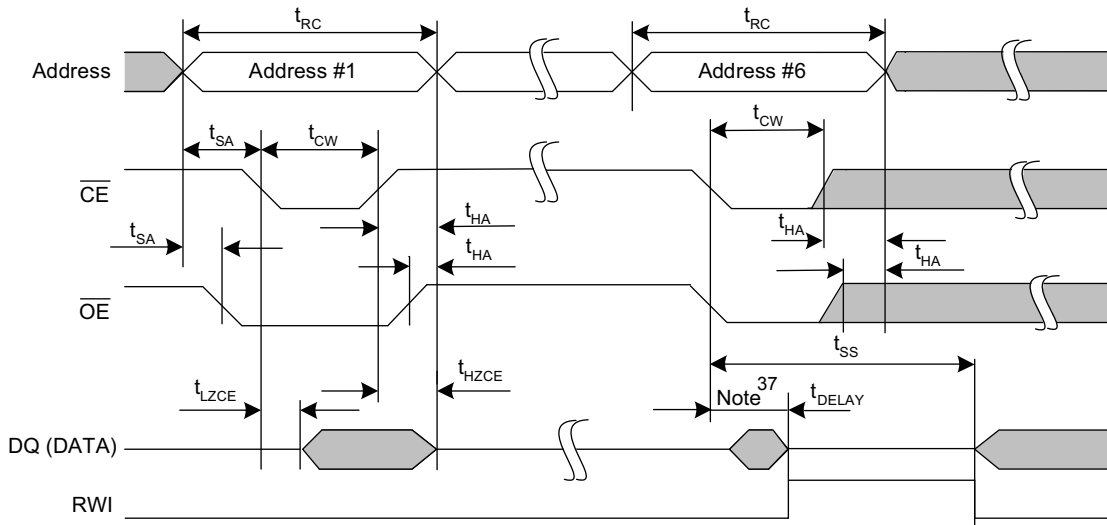

Figure 12. Autostore Enable/Disable Cycle ^[36]



Notes

35. The software sequence is clocked with \overline{CE} controlled or \overline{OE} controlled reads.

36. The six consecutive addresses must be read in the order listed in [Table 1](#) on [page 7](#). \overline{WE} must be HIGH during all six consecutive cycles.

37. DQ output data at the sixth read may be invalid since the output is disabled at t_{DELAY} time.

Hardware STORE Cycle

Over the [Operating Range](#)

Parameter	Description	20 ns		25 ns		45 ns		Unit
		Min	Max	Min	Max	Min	Max	
t_{DHSB}	HSB to output active time when write latch not set	–	20	–	25	–	25	ns
t_{PHSB}	Hardware STORE pulse width	15	–	15	–	15	–	ns
t_{SS} [38, 39]	Soft sequence processing time	–	100	–	100	–	100	μs

Switching Waveforms

Figure 13. Hardware STORE Cycle [40]

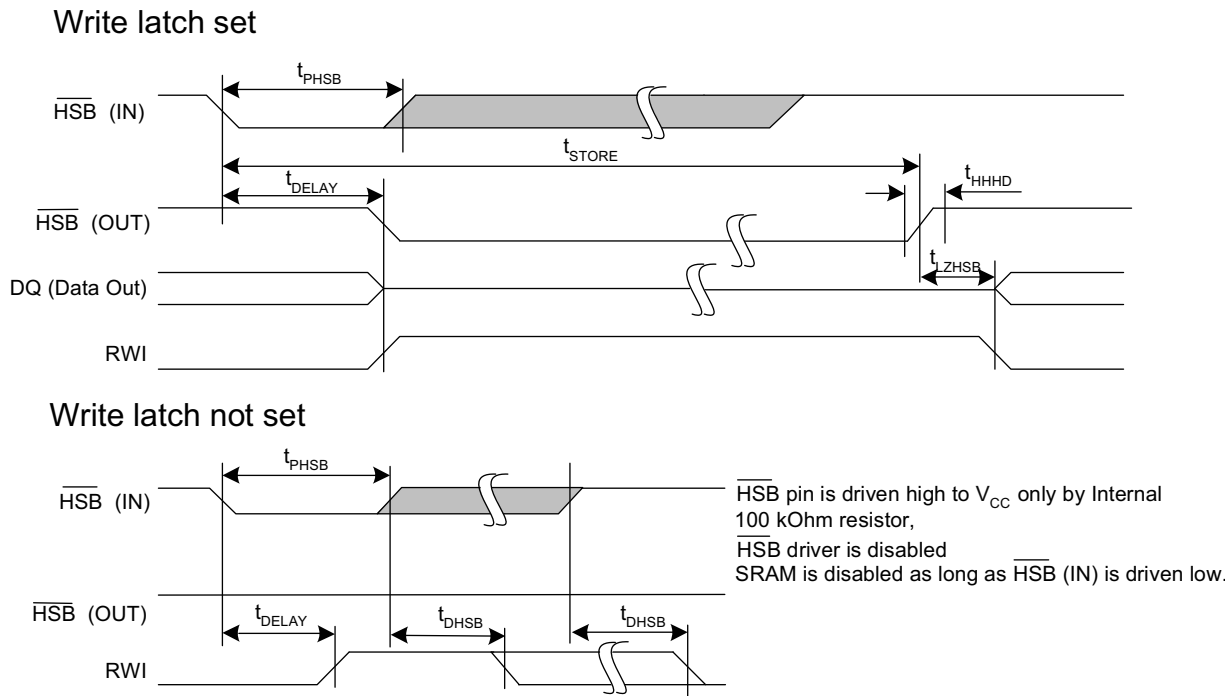
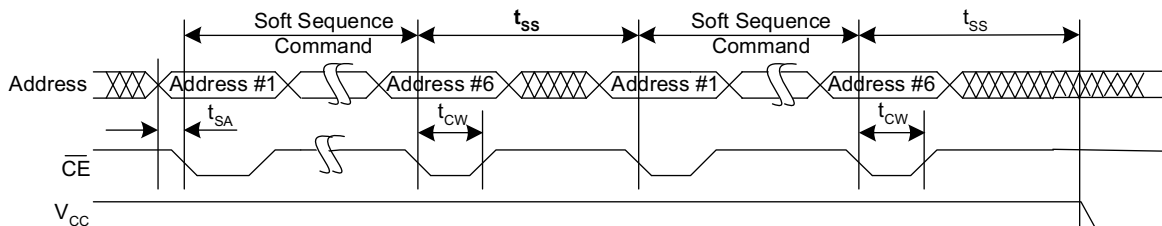

Figure 14. Soft Sequence Processing [38, 39]



Notes

38. This is the amount of time it takes to take action on a soft sequence command. V_{CC} power must remain HIGH to effectively register command.
 39. Commands such as STORE and RECALL lock out I/O until operation is complete which further increases this time. See the specific command.
 40. If an SRAM write has not taken place since the last nonvolatile cycle, no AutoStore or Hardware STORE takes place.



Truth Table For SRAM Operations

HSB should remain HIGH for SRAM Operations.

Table 2. Truth Table for × 8 Configuration

$\overline{\text{CE}}$	$\overline{\text{WE}}$	$\overline{\text{OE}}$	Inputs/Outputs ^[41]	Mode	Power
H	X	X	High Z	Deselect/Power-down	Standby
L	H	L	Data out (DQ ₀ –DQ ₇);	Read	Active
L	H	H	High Z	Output disabled	Active
L	L	X	Data in (DQ ₀ –DQ ₇);	Write	Active

Table 3. Truth Table for × 16 Configuration

$\overline{\text{CE}}$	$\overline{\text{WE}}$	$\overline{\text{OE}}$	$\overline{\text{BHE}}$ ^[42]	$\overline{\text{BLE}}$ ^[42]	Inputs/Outputs ^[41]	Mode	Power
H	X	X	X	X	High Z	Deselect/Power-down	Standby
L	X	X	H	H	High Z	Output disabled	Active
L	H	L	L	L	Data out (DQ ₀ –DQ ₁₅)	Read	Active
L	H	L	H	L	Data out (DQ ₀ –DQ ₇); DQ ₈ –DQ ₁₅ in High Z	Read	Active
L	H	L	L	H	Data out (DQ ₈ –DQ ₁₅); DQ ₀ –DQ ₇ in High Z	Read	Active
L	H	H	L	L	High Z	Output disabled	Active
L	H	H	H	L	High Z	Output disabled	Active
L	H	H	L	H	High Z	Output disabled	Active
L	L	X	L	L	Data in (DQ ₀ –DQ ₁₅)	Write	Active
L	L	X	H	L	Data in (DQ ₀ –DQ ₇); DQ ₈ –DQ ₁₅ in High Z	Write	Active
L	L	X	L	H	Data in (DQ ₈ –DQ ₁₅); DQ ₀ –DQ ₇ in High Z	Write	Active

Notes

41. Data DQ₀–DQ₇ for × 8 configuration and Data DQ₀–DQ₁₅ for × 16 configuration.

42. BHE and BLE are applicable for × 16 configuration only.



Ordering Information

Speed (ns)	Ordering Code	Package Diagram	Package Type	Operating Range
20	CY14B108L-ZS20XIT	51-85087	44-pin TSOP II	Industrial
	CY14B108L-ZS20XI	51-85087	44-pin TSOP II	
25	CY14B108L-ZS25XIT	51-85087	44-pin TSOP II	
	CY14B108L-ZS25XI	51-85087	44-pin TSOP II	
	CY14B108L-BA25XIT	51-85128	48-ball FBGA	
	CY14B108L-BA25XI	51-85128	48-ball FBGA	
	CY14B108N-BA25XIT	51-85128	48-ball FBGA	
	CY14B108N-BA25XI	51-85128	48-ball FBGA	
	CY14B108N-ZSP25XIT	51-85160	54-pin TSOP II	
	CY14B108N-ZSP25XI	51-85160	54-pin TSOP II	
45	CY14B108L-ZS45XIT	51-85087	44-pin TSOP II	
	CY14B108L-ZS45XI	51-85087	44-pin TSOP II	
	CY14B108L-BA45XIT	51-85128	48-ball FBGA	
	CY14B108L-BA45XI	51-85128	48-ball FBGA	
	CY14B108N-BA45XIT	51-85128	48-ball FBGA	
	CY14B108N-BA45XI	51-85128	48-ball FBGA	
	CY14B108N-ZSP45XIT	51-85160	54-pin TSOP II	
	CY14B108N-ZSP45XI	51-85160	54-pin TSOP II	

All the above parts are Pb-free.

Ordering Code Definitions

CY 14 B 108 L - ZS 20 X I T

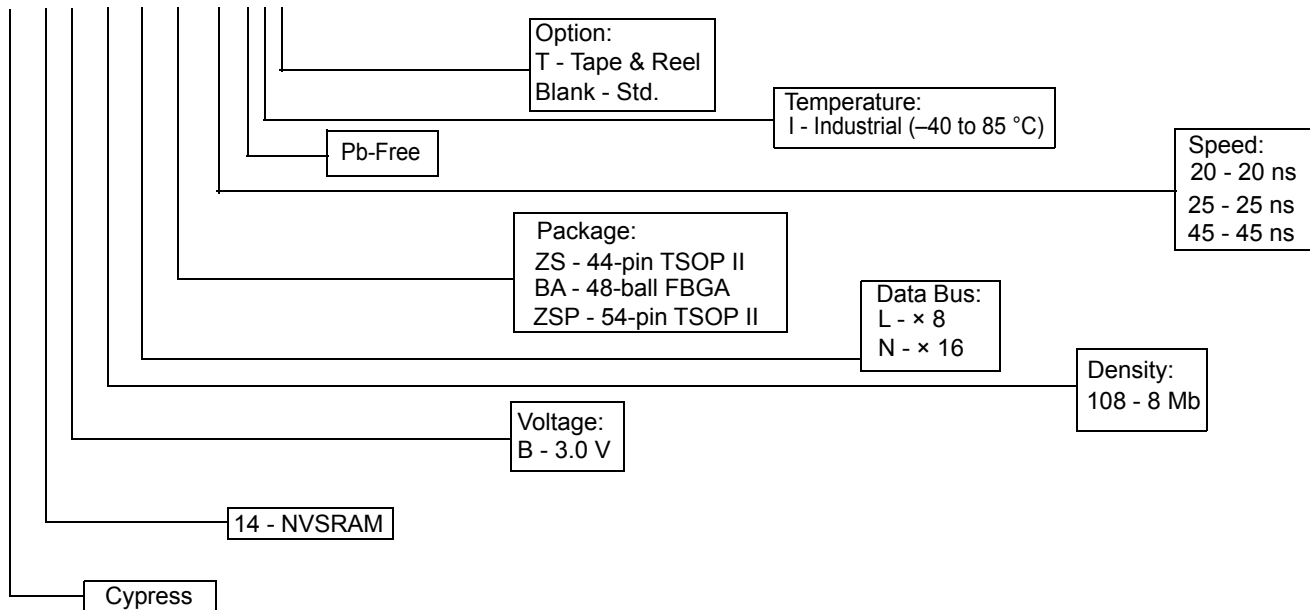

Package Diagrams

Figure 15. 44-pin TSOP II Package Outline, 51-85087

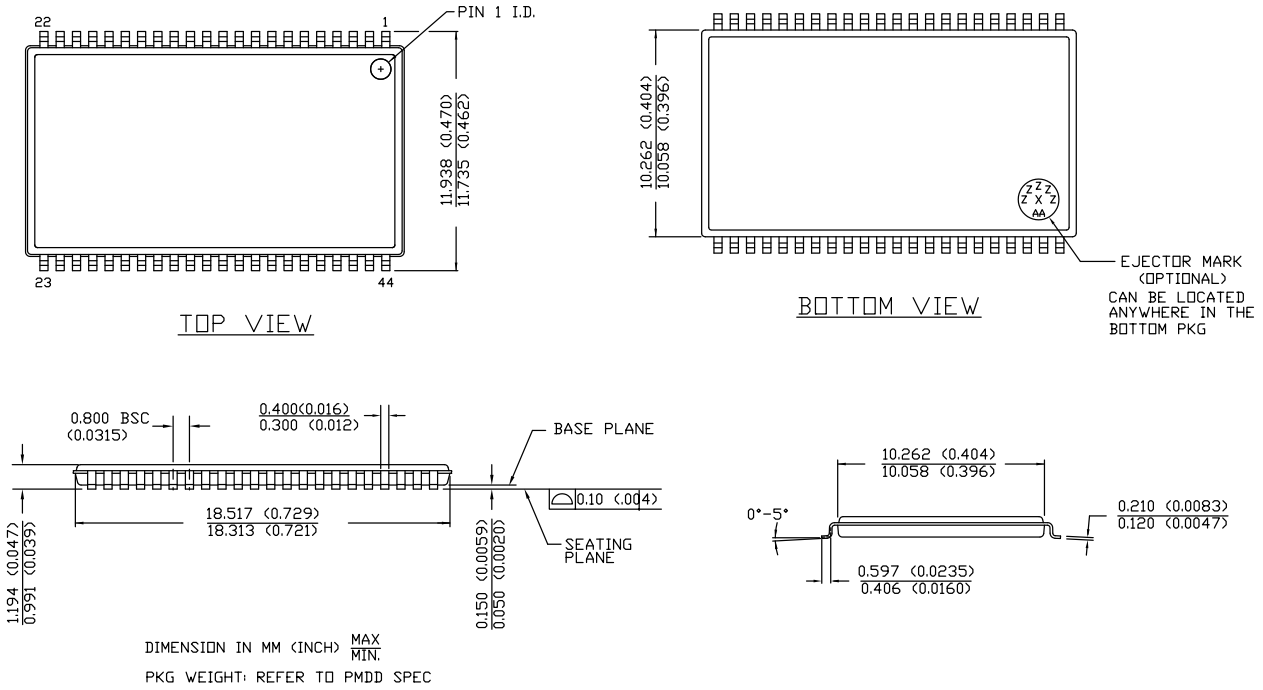

51-85087 *E



CY14B108L
CY14B108N

Package Diagrams (continued)

Figure 16. 48-ball FBGA (6 × 10 × 1.2 mm) Package Outline, 51-85128

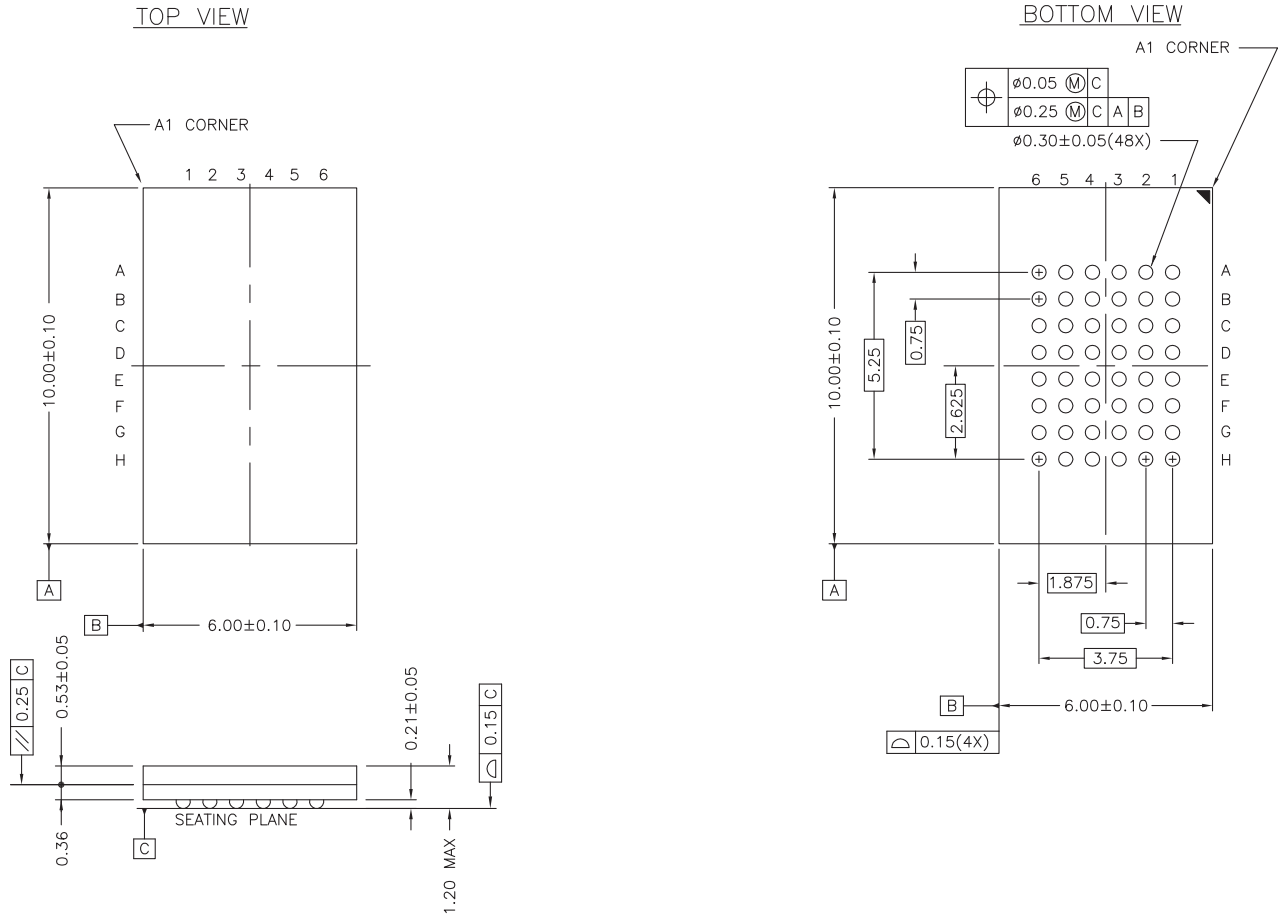

51-85128 *G



Package Diagrams (continued)

Figure 17. 54-pin TSOP II (22.4 × 11.84 × 1.0 mm) Package Outline, 51-85160

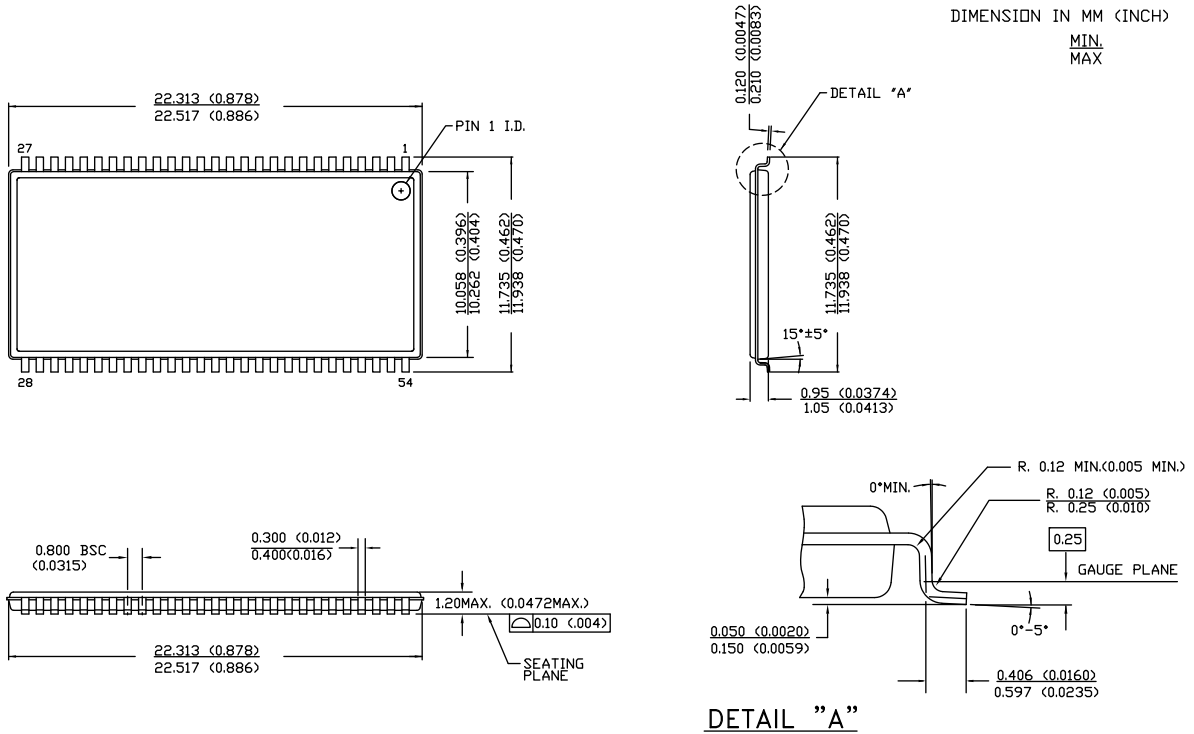

51-85160 *E



Acronyms

Acronym	Description
CMOS	complementary metal oxide semiconductor
$\overline{\text{BHE}}$	byte high enable
$\overline{\text{BLE}}$	byte low enable
$\overline{\text{CE}}$	chip enable
EIA	electronic industries alliance
FBGA	fine-pitch ball grid array
$\overline{\text{HSB}}$	hardware store busy
I/O	input/output
nvSRAM	non-volatile static random access memory
$\overline{\text{OE}}$	output enable
RoHS	restriction of hazardous substances
RWI	read and write inhibited
SRAM	static random access memory
TSOP	thin small outline package
$\overline{\text{WE}}$	write enable

Document Conventions

Units of Measure

Symbol	Unit of Measure
$^{\circ}\text{C}$	degree Celsius
$\text{k}\Omega$	kilohm
kHz	kilohertz
MHz	megahertz
μA	microampere
μF	microfarad
μs	microsecond
mA	milliampere
ms	millisecond
ns	nanosecond
Ω	ohm
%	percent
pF	picofarad
s	second
V	volt
W	watt



Errata

This section describes the errata for the 8 Mb (2048 K × 8 and 1024 K × 16) nvSRAM product families. Details include errata trigger conditions, scope of impact, available workarounds, and silicon revision applicability.

Contact your local Cypress Sales Representative if you have questions. You can also send your related queries directly to nvSRAM@cypress.com.

Part Numbers Affected

Part Number	Device Characteristics
CY14B108L	1024 K × 8, Asynchronous Interface nvSRAM in 44 TSOP-II and 48 FBGA package options
CY14B108N	512 K × 16, Asynchronous Interface nvSRAM in 54 TSOP-II and 48 FBGA package options

8Mb (1024 K × 8, 512 K × 16) nvSRAM Qualification Status

Production parts.

8Mb (1024 K × 8, 512 K × 16) nvSRAM Errata Summary

The following table defines the errata applicability to available CY14B108L, CY14B108N devices.

Items	Part Number	Silicon Revision	Fix Status
1. AutoStore Disable feature does not work correctly	CY14B108L CY14B108N	Rev 0	None. This issue is applicable to all 8Mb nvSRAM parts in production

1. [AutoStore Disable feature does not work correctly](#)

■ Problem Definition

The AutoStore Disable soft sequence disables the AutoStore feature in nvSRAMs. The AutoStore Disable feature is used in applications where data written in the SRAM is not required to be saved automatically on power loss. The 8Mb nvSRAM executes the nonvolatile Store automatically in half the memory (4Mb) even after the AutoStore feature is disabled. The reason is as follows:

The 8Mb nvSRAM uses two dice stack of 4Mb with HSB pin of each die are tied together. Each nvSRAM die in the stacked-die monitors the V_{CC} power independently. When the device V_{CC} fails, the die which detects the V_{CC} dropping below V_{SWITCH} first, internally triggers the power down interrupt and drives its HSB output low. Since the HSB is a bidirectional pin, the low HSB output driven by one die is detected as HSB input by the other die. Therefore, low on the HSB input of other die internally triggers hardware Store and executes unintended nonvolatile Store even though AutoStore was disabled by AutoStore Disable soft sequence.

■ Parameters Affected

None.

■ Trigger Condition(S)

Device V_{CC} power down with nvSRAM AutoStore disable.

■ Scope of Impact

It can corrupt the data in half of the memory by overwriting the existing data in its nonvolatile memory with unintended data.

■ Workaround

None. AutoStore disable feature should not be used in 8Mb nvSRAMs.

■ Fix Status

This issue is applicable to all 8Mb nvSRAM parts in production and will continue serving with errata. There is no plan to fix this issue in the existing parts in production.



Document History Page

Document Title: CY14B108L/CY14B108N, 8-Mbit (1024 K × 8/512 K × 16) nvSRAM				
Document Number: 001-45523				
Revision	ECN	Orig. of Change	Submission Date	Description of Change
**	2428826	GVCH	See ECN	New Data Sheet
*A	2520023	GVCH / PYRS	06/23/08	Updated I _{CC1} for t _{RC} =20ns, 25ns and 45ns access speed for both industrial and Commercial temperature Grade Updated Thermal resistance values for 48-FBGA,44-TSOP II and 54-TSOP II packages Changed t _{CW} value from 16ns to 15ns
*B	2676670	GVCH / PYRS	03/20/2009	Added maximum accumulated storage time for 150°C and 85°C Temperature Added best practices Changed I _{CC2} from 12mA to 20mA Changed I _{CC3} from 38mA to 40mA Changed I _{CC4} from 12mA to 10mA Changed I _{SB} from 6mA to 10mA Changed V _{CAP} from 164uF to 360uF Changed Input Rise and Fall Times from 5ns to 3ns Updated I _{CC1} , I _{CC3} , I _{SB} and I _{OZ} Test conditions Changed t _{DELAY} to 20ns, 25ns, 25ns for 15ns, 20ns, 45ns part respectively Changed t _{STORE} from 15ms to 8ms Added V _{HDIS} , t _{HHD} and t _{LZHSB} parameters Software controlled STORE/RECALL cycle table: Changed t _{AS} to t _{SA} Changed t _{GHAX} to t _{HA} Added t _{DHSB} parameter Changed t _{HLHX} to t _{PHSB} Updated t _{SS} from 70us to 100us Added Truth table for SRAM operations Updated ordering information
*C	2712462	GVCH / PYRS	05/29/2009	Moved data sheet status from Preliminary to Final Updated AutoStore operation Updated I _{SB} test condition Updated footnote 7 Referenced footnote 9 to V _{CCRISE} , t _{HHD} and t _{LZHSB} parameters Updated V _{HDIS} parameter description
*D	2746310	GVCH	07/29/2009	Page 4: Updated Hardware STORE (HSB) operation description page 5: Updated Software STORE description Updated t _{DELAY} parameter description Updated footnote 18 and added footnote 23 Referenced footnote 23 to Figure 11 and Figure 12
*E	2759948	GVCH	09/04/2009	Removed commercial temperature related specs
*F	2828257	GVCH	12/15/2009	Changed STORE cycles to QuantumTrap from 200K to 1 Million Added Contents on page 2
*G	2894560	GVCH	03/18/2010	Removed part numbers CY14B108N-ZSP20XIT and CY14B108N-ZSP20XI from ordering information table. Updated Package diagrams 51-85160 and 51-85087. Updated Sales, Solution, and Legal Information Section. Updated copyright section. Updated table of contents.
*H	2923475	GVCH / AESA	04/27/2010	Table 1 : Added more clarity on HSB pin operation Hardware STORE Operation : Added more clarity on HSB pin operation Table 1 : Added more clarity on BHE/BLE pin operation Updated HSB pin operation in Figure 10 Updated footnote 34



Document History Page (continued)

Document Title: CY14B108L/CY14B108N, 8-Mbit (1024 K × 8/512 K × 16) nvSRAM				
Document Number: 001-45523				
Revision	ECN	Orig. of Change	Submission Date	Description of Change
*I	3143765	GVCH	01/17/2011	48-ball FBGA package: 16 Mb address expansion is not supported Updated thermal resistance values for all packages Added Acronyms table and Document Conventions table
*J	3311413	GVCH	07/13/2011	Updated DC Electrical Characteristics (Added Note 9 and referred the same note in V _{CAP} parameter). Updated AC Switching Characteristics (Added Note 13 and referred the same note in Parameters). Updated Package Diagrams .
*K	3580269	GVCH	04/12/2012	Updated Package Diagrams .
*L	3658005	GVCH	08/10/2012	Updated Maximum Ratings (Changed “Ambient temperature with power applied” to “Maximum junction temperature”). Updated DC Electrical Characteristics (Added V _{V_{CAP}} parameter and its details, added Note 11 and referred the same note in V _{V_{CAP}} parameter, also referred Note 12 in V _{V_{CAP}} parameter). Updated Package Diagrams (spec 51-85160 (Changed revision from *C to *D)).
*M	4500772	ZSK	09/12/2014	Updated Package Diagrams : spec 51-85087 – Changed revision from *D to *E. spec 51-85160 – Changed revision from *D to *E. Added Errata . Updated to new template.
*N	4563189	ZSK	11/12/2014	Added related documentation hyperlink in page 1
*O	4714292	GVCH	04/08/2015	No technical updates. Completing Sunset Review.
*P	5705809	AESATMP7	04/21/2017	Updated Cypress Logo and Copyright.



Sales, Solutions, and Legal Information

Worldwide Sales and Design Support

Cypress maintains a worldwide network of offices, solution centers, manufacturer's representatives, and distributors. To find the office closest to you, visit us at [Cypress Locations](#).

Products

ARM® Cortex® Microcontrollers	cypress.com/arm
Automotive	cypress.com/automotive
Clocks & Buffers	cypress.com/clocks
Interface	cypress.com/interface
Internet of Things	cypress.com/iot
Memory	cypress.com/memory
Microcontrollers	cypress.com/mcu
PSoC	cypress.com/psoc
Power Management ICs	cypress.com/pmic
Touch Sensing	cypress.com/touch
USB Controllers	cypress.com/usb
Wireless Connectivity	cypress.com/wireless

PSoC® Solutions

[PSoC 1](#) | [PSoC 3](#) | [PSoC 4](#) | [PSoC 5LP](#) | [PSoC 6](#)

Cypress Developer Community

[Forums](#) | [WICED IoT Forums](#) | [Projects](#) | [Video](#) | [Blogs](#) | [Training](#) | [Components](#)

Technical Support

cypress.com/support

All other trademarks or registered trademarks referenced herein are the property of their respective owners.

© Cypress Semiconductor Corporation, 2008-2017. This document is the property of Cypress Semiconductor Corporation and its subsidiaries, including Spansion LLC ("Cypress"). This document, including any software or firmware included or referenced in this document ("Software"), is owned by Cypress under the intellectual property laws and treaties of the United States and other countries worldwide. Cypress reserves all rights under such laws and treaties and does not, except as specifically stated in this paragraph, grant any license under its patents, copyrights, trademarks, or other intellectual property rights. If the Software is not accompanied by a license agreement and you do not otherwise have a written agreement with Cypress governing the use of the Software, then Cypress hereby grants you a personal, non-exclusive, nontransferable license (without the right to sublicense) (1) under its copyright rights in the Software (a) for Software provided in source code form, to modify and reproduce the Software solely for use with Cypress hardware products, only internally within your organization, and (b) to distribute the Software in binary code form externally to end users (either directly or indirectly through resellers and distributors), solely for use on Cypress hardware product units, and (2) under those claims of Cypress's patents that are infringed by the Software (as provided by Cypress, unmodified) to make, use, distribute, and import the Software solely for use with Cypress hardware products. Any other use, reproduction, modification, translation, or compilation of the Software is prohibited.

TO THE EXTENT PERMITTED BY APPLICABLE LAW, CYPRESS MAKES NO WARRANTY OF ANY KIND, EXPRESS OR IMPLIED, WITH REGARD TO THIS DOCUMENT OR ANY SOFTWARE OR ACCOMPANYING HARDWARE, INCLUDING, BUT NOT LIMITED TO, THE IMPLIED WARRANTIES OF MERCHANTABILITY AND FITNESS FOR A PARTICULAR PURPOSE. To the extent permitted by applicable law, Cypress reserves the right to make changes to this document without further notice. Cypress does not assume any liability arising out of the application or use of any product or circuit described in this document. Any information provided in this document, including any sample design information or programming code, is provided only for reference purposes. It is the responsibility of the user of this document to properly design, program, and test the functionality and safety of any application made of this information and any resulting product. Cypress products are not designed, intended, or authorized for use as critical components in systems designed or intended for the operation of weapons, weapons systems, nuclear installations, life-support devices or systems, other medical devices or systems (including resuscitation equipment and surgical implants), pollution control or hazardous substances management, or other uses where the failure of the device or system could cause personal injury, death, or property damage ("Unintended Uses"). A critical component is any component of a device or system whose failure to perform can be reasonably expected to cause the failure of the device or system, or to affect its safety or effectiveness. Cypress is not liable, in whole or in part, and you shall and hereby do release Cypress from any claim, damage, or other liability arising from or related to all Unintended Uses of Cypress products. You shall indemnify and hold Cypress harmless from and against all claims, costs, damages, and other liabilities, including claims for personal injury or death, arising from or related to any Unintended Uses of Cypress products.

Cypress, the Cypress logo, Spansion, the Spansion logo, and combinations thereof, WICED, PSoC, CapSense, EZ-USB, F-RAM, and Traveo are trademarks or registered trademarks of Cypress in the United States and other countries. For a more complete list of Cypress trademarks, visit cypress.com. Other names and brands may be claimed as property of their respective owners.

OUR CERTIFICATE

DiGi provide top-quality products and perfect service for customer worldwide through standardization, technological innovation and continuous improvement. DiGi through third-party certification, we stricly control the quality of products and services. Welcome your RFQ to

Email: Info@DiGi-Electronics.com



Tel: +00 852-30501935

RFQ Email: Info@DiGi-Electronics.com

DiGi is a global authorized distributor of electronic components.