

# CY62146EV30LL-45BVXI Datasheet



[www.digi-electronics.com](http://www.digi-electronics.com)

<https://www.DiGi-Electronics.com>

DiGi Electronics Part Number	CY62146EV30LL-45BVXI-DG
Manufacturer	<a href="#">Infineon Technologies</a>
Manufacturer Product Number	CY62146EV30LL-45BVXI
Description	IC SRAM 4MBIT PARALLEL 48VFBGA
Detailed Description	SRAM - Asynchronous Memory IC 4Mbit Parallel 45 ns 48-VFBGA (6x8)

This model CY62146EV30LL-45BVXI is available at DiGi Electronics.

DiGi Electronics offers a global database of semiconductor and electronic component datasheets.

We welcome your inquiries regarding pricing, lead time, or other product-related questions.

 [Request a Quote](#)

 [Datasheet Search](#)



Tel: +00 852-30501935

RFQ Email: [Info@DiGi-Electronics.com](mailto:Info@DiGi-Electronics.com)

DiGi is a global authorized distributor of electronic components.

## Purchase and inquiry

Manufacturer Product Number:

CY62146EV30LL-45BVXI

Series:

MoBL®

DiGi-Electronics Programmable:

Not Verified

Memory Format:

SRAM

Memory Size:

4Mbit

Memory Interface:

Parallel

Access Time:

45 ns

Operating Temperature:

-40°C ~ 85°C (TA)

Package / Case:

48-VFBGA

Base Product Number:

CY62146

Manufacturer:

Infineon Technologies

Product Status:

Active

Memory Type:

Volatile

Technology:

SRAM - Asynchronous

Memory Organization:

256K x 16

Write Cycle Time - Word, Page:

45ns

Voltage - Supply:

2.2V ~ 3.6V

Mounting Type:

Surface Mount

Supplier Device Package:

48-VFBGA (6x8)

## Environmental & Export classification

RoHS Status:

ROHS3 Compliant

REACH Status:

REACH Unaffected

HTSUS:

8542.32.0041

Moisture Sensitivity Level (MSL):

3 (168 Hours)

ECCN:

3A991B2A



**Please note that Cypress is an Infineon Technologies Company.**

The document following this cover page is marked as “Cypress” document as this is the company that originally developed the product. Please note that Infineon will continue to offer the product to new and existing customers as part of the Infineon product portfolio.

**Continuity of document content**

The fact that Infineon offers the following product as part of the Infineon product portfolio does not lead to any changes to this document. Future revisions will occur when appropriate, and any changes will be set out on the document history page.

**Continuity of ordering part numbers**

Infineon continues to support existing part numbers. Please continue to use the ordering part numbers listed in the datasheet for ordering.



CY62146EV30 MoBL

## 4-Mbit (256K × 16) Static RAM

## Features

- Very high speed: 45 ns
- Temperature ranges
  - Industrial: -40 °C to +85 °C
  - Automotive-A: -40 °C to +85 °C
- Wide voltage range: 2.20 V to 3.60 V
- Pin compatible with CY62146DV30
- Ultra low standby power
  - Typical standby current: 2.5  $\mu$ A
  - Maximum standby current: 7  $\mu$ A
- Ultra low active power
  - Typical active current: 3.5 mA at f = 1 MHz
- Easy memory expansion with  $\overline{CE}$  and  $\overline{OE}$  features
- Automatic power down when deselected
- Complementary metal oxide semiconductor (CMOS) for optimum speed and power
- Available in a Pb-free 48-ball very fine-pitch ball grid array (VFBGA) and 44-pin TSOP II Packages

## Functional Description

The CY62146EV30 is a high performance CMOS static RAM organized as 256K words by 16 bits. This device features an

advanced circuit design designed to provide an ultra low active current. Ultra low active current is ideal for providing More Battery Life™ (MoBL®) in portable applications such as cellular telephones. The device also has an automatic power down feature that significantly reduces power consumption by 80 percent when addresses are not toggling. The device can also be put into standby mode reducing power consumption by more than 99 percent when deselected ( $\overline{CE}$  HIGH). The input and output pins (I/O<sub>0</sub> through I/O<sub>15</sub>) are placed in a high impedance state when the device is deselected ( $\overline{CE}$  HIGH), outputs are disabled ( $\overline{OE}$  HIGH), both Byte High Enable and Byte Low Enable are disabled ( $\overline{BHE}$ ,  $\overline{BLE}$  HIGH), or a write operation is in progress ( $\overline{CE}$  LOW and  $\overline{WE}$  LOW).

To write to the device, take Chip Enable ( $\overline{CE}$ ) and Write Enable ( $\overline{WE}$ ) input LOW. If Byte Low Enable ( $\overline{BLE}$ ) is LOW, then data from I/O pins (I/O<sub>0</sub> through I/O<sub>7</sub>) is written into the location specified on the address pins (A<sub>0</sub> through A<sub>17</sub>). If Byte High Enable ( $\overline{BHE}$ ) is LOW, then data from the I/O pins (I/O<sub>8</sub> through I/O<sub>15</sub>) is written into the location specified on the address pins (A<sub>0</sub> through A<sub>17</sub>).

To read from the device, take Chip Enable ( $\overline{CE}$ ) and Output Enable ( $\overline{OE}$ ) LOW while forcing the Write Enable ( $\overline{WE}$ ) HIGH. If Byte Low Enable ( $\overline{BLE}$ ) is LOW, then data from the memory location specified by the address pins appears on I/O<sub>0</sub> to I/O<sub>7</sub>. If Byte High Enable ( $\overline{BHE}$ ) is LOW, then data from memory appears on I/O<sub>8</sub> to I/O<sub>15</sub>. See the Truth Table on page 11 for a complete description of read and write modes.

For a complete list of related documentation, [click here](#).

## Logic Block Diagram

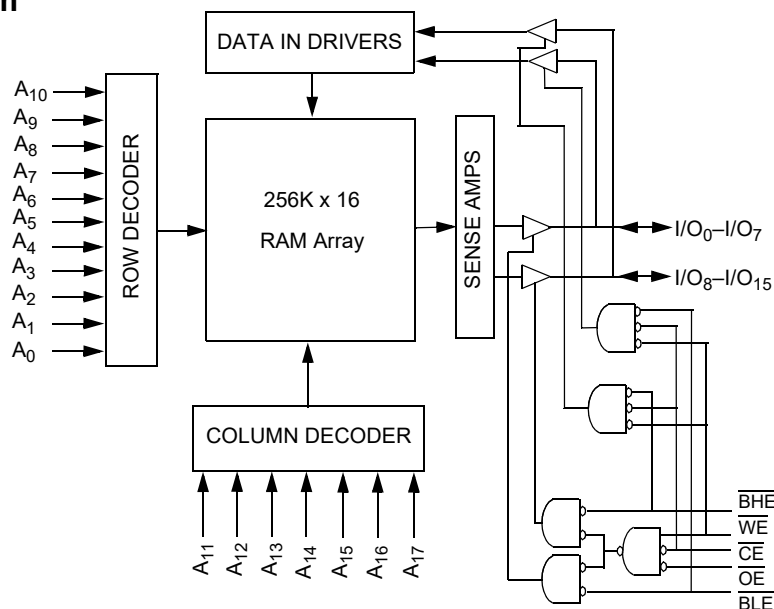



## Contents

<b>Pin Configurations</b> .....	<b>3</b>	<b>Ordering Information</b> .....	<b>12</b>
<b>Product Portfolio</b> .....	<b>3</b>	Ordering Code Definitions .....	12
<b>Maximum Ratings</b> .....	<b>4</b>	<b>Package Diagrams</b> .....	<b>13</b>
<b>Operating Range</b> .....	<b>4</b>	<b>Acronyms</b> .....	<b>15</b>
<b>Electrical Characteristics</b> .....	<b>4</b>	<b>Document Conventions</b> .....	<b>15</b>
<b>Capacitance</b> .....	<b>5</b>	Units of Measure .....	15
<b>Thermal Resistance</b> .....	<b>5</b>	<b>Document History Page</b> .....	<b>16</b>
<b>AC Test Loads and Waveforms</b> .....	<b>5</b>	<b>Sales, Solutions, and Legal Information</b> .....	<b>19</b>
<b>Data Retention Characteristics</b> .....	<b>6</b>	Worldwide Sales and Design Support .....	19
<b>Data Retention Waveform</b> .....	<b>6</b>	Products .....	19
<b>Switching Characteristics</b> .....	<b>7</b>	PSoC® Solutions .....	19
<b>Switching Waveforms</b> .....	<b>8</b>	Cypress Developer Community .....	19
<b>Truth Table</b> .....	<b>11</b>	Technical Support .....	19

## Pin Configurations

Figure 1. 48-ball VFBGA pinout <sup>[1, 2]</sup>

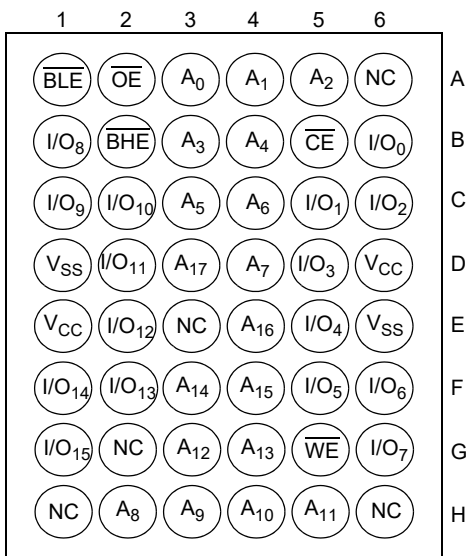
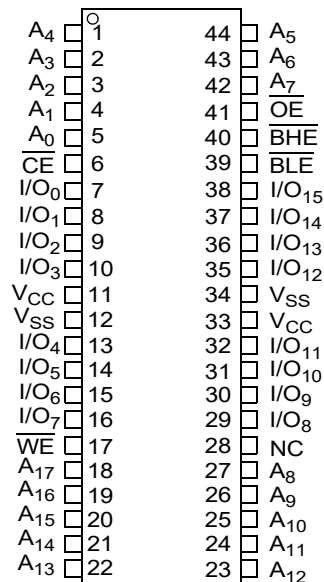

Figure 2. 44-pin TSOP II pinout <sup>[1]</sup>



## Product Portfolio

Product	Range	V <sub>CC</sub> Range (V)			Speed (ns)	Power Dissipation					
						Operating I <sub>CC</sub> (mA)				Standby I <sub>SB2</sub> (μA)	
		f = 1 MHz		f = f <sub>max</sub>							
		Min	Typ <sup>[3]</sup>	Max		Typ <sup>[3]</sup>	Max	Typ <sup>[3]</sup>	Max	Typ <sup>[3]</sup>	Max
CY62146EV30LL	Industrial/ Automotive-A	2.2	3.0	3.6	45	3.5	6	15	20	2.5	7

### Notes

- NC pins are not connected on the die.
- Pins H1, G2, and H6 in the BGA package are address expansion pins for 8Mb, 16Mb and 32Mb respectively.
- Typical values are included for reference only and are not guaranteed or tested. Typical values are measured at V<sub>CC</sub> = V<sub>CC(typ)</sub>, T<sub>A</sub> = 25 °C.



## Maximum Ratings

Exceeding the maximum ratings may impair the useful life of the device. These user guidelines are not tested.

Storage temperature .....  $-65\text{ }^{\circ}\text{C}$  to  $+150\text{ }^{\circ}\text{C}$

Ambient temperature  
with power applied .....  $-55\text{ }^{\circ}\text{C}$  to  $+125\text{ }^{\circ}\text{C}$

Supply voltage  
to ground potential .....  $-0.3\text{ V}$  to  $+3.9\text{ V}$  ( $V_{CCmax} + 0.3\text{ V}$ )

DC voltage applied to outputs  
in High-Z state <sup>[4, 5]</sup> .....  $-0.3\text{ V}$  to  $+3.9\text{ V}$  ( $V_{CCmax} + 0.3\text{ V}$ )

DC input voltage <sup>[4, 5]</sup> .....  $-0.3\text{ V}$  to  $+3.9\text{ V}$  ( $V_{CCmax} + 0.3\text{ V}$ )

Output current into outputs (LOW) .....  $20\text{ mA}$

Static Discharge Voltage  
(per MIL-STD-883, Method 3015) .....  $>2001\text{ V}$

Latch-up Current .....  $>200\text{ mA}$

## Operating Range

Device	Range	Ambient Temperature	$V_{CC}$ <sup>[6]</sup>
CY62146EV30	Industrial/ Automotive-A	$-40\text{ }^{\circ}\text{C}$ to $+85\text{ }^{\circ}\text{C}$	$2.2\text{ V}$ to $3.6\text{ V}$

## Electrical Characteristics

Over the Operating Range

Parameter	Description	Test Conditions	45 ns (Industrial/Automotive-A)			Unit
			Min	Typ <sup>[7]</sup>	Max	
$V_{OH}$	Output high voltage	$I_{OH} = -0.1\text{ mA}$	2.0	–	–	V
		$I_{OH} = -1.0\text{ mA}$ , $V_{CC} \geq 2.70\text{ V}$	2.4	–	–	V
$V_{OL}$	Output low voltage	$I_{OL} = 0.1\text{ mA}$	–	–	0.4	V
		$I_{OL} = 2.1\text{ mA}$ , $V_{CC} \geq 2.70\text{ V}$	–	–	0.4	V
$V_{IH}$	Input high voltage	$V_{CC} = 2.2\text{ V}$ to $2.7\text{ V}$	1.8	–	$V_{CC} + 0.3$	V
		$V_{CC} = 2.7\text{ V}$ to $3.6\text{ V}$	2.2	–	$V_{CC} + 0.3$	V
$V_{IL}$	Input LOW Voltage	$V_{CC} = 2.2\text{ V}$ to $2.7\text{ V}$	$-0.3$	–	0.6	V
		$V_{CC} = 2.7\text{ V}$ to $3.6\text{ V}$	$-0.3$	–	0.8	V
$I_{IX}$	Input leakage current	$GND \leq V_I \leq V_{CC}$	$-1$	–	$+1$	$\mu\text{A}$
$I_{OZ}$	Output leakage current	$GND \leq V_O \leq V_{CC}$ , Output disabled	$-1$	–	$+1$	$\mu\text{A}$
$I_{CC}$	$V_{CC}$ operating supply current	$f = f_{max} = 1/t_{RC}$	–	15	20	mA
		$f = 1\text{ MHz}$		3.5	6	
$I_{SB1}$	Automatic CE power down current – CMOS inputs	$\overline{CE} > V_{CC} - 0.2\text{ V}$ , $V_{IN} > V_{CC} - 0.2\text{ V}$ or $V_{IN} < 0.2\text{ V}$ , $f = f_{max}$ (Address and data only),  $f = 0$ ( $\overline{OE}$ , $\overline{BHE}$ , $\overline{BLE}$ and $\overline{WE}$ ), $V_{CC} = 3.60\text{ V}$	–	2.5	7	$\mu\text{A}$
$I_{SB2}$ <sup>[8]</sup>	Automatic CE power down current – CMOS inputs	$\overline{CE} \geq V_{CC} - 0.2\text{ V}$ , $V_{IN} \geq V_{CC} - 0.2\text{ V}$ or $V_{IN} \leq 0.2\text{ V}$ , $f = 0$ , $V_{CC} = 3.60\text{ V}$	–	2.5	7	$\mu\text{A}$

### Notes

4.  $V_{IL(min)}$  =  $-2.0\text{ V}$  for pulse durations less than  $20\text{ ns}$ .

5.  $V_{IH(max)}$  =  $V_{CC} + 0.75\text{ V}$  for pulse durations less than  $20\text{ ns}$ .

6. Full device AC operation assumes a minimum of  $100\text{ }\mu\text{s}$  ramp time from  $0$  to  $V_{CC(min)}$  and  $200\text{ }\mu\text{s}$  wait time after  $V_{CC}$  stabilization.

7. Typical values are included for reference only and are not guaranteed or tested. Typical values are measured at  $V_{CC} = V_{CC(typ)}$ ,  $T_A = 25\text{ }^{\circ}\text{C}$ .

8. Chip enable ( $\overline{CE}$ ) and byte enables ( $\overline{BHE}$  and  $\overline{BLE}$ ) need to be tied to CMOS levels to meet the  $I_{SB1}/I_{SB2}/I_{CCDR}$  spec. Other inputs can be left floating.

## Capacitance

Parameter <sup>[9]</sup>	Description	Test Conditions	Max	Unit
$C_{IN}$	Input capacitance	$T_A = 25\text{ }^\circ\text{C}$ , $f = 1\text{ MHz}$ , $V_{CC} = V_{CC(\text{typ})}$	10	pF
$C_{OUT}$	Output capacitance		10	pF

## Thermal Resistance

Parameter <sup>[9]</sup>	Description	Test Conditions	VFBGA	TSOP II	Unit
$\Theta_{JA}$	Thermal resistance (junction to ambient)	Still air, soldered on a 3 × 4.5 inch, four-layer printed circuit board	42.10	55.52	$^\circ\text{C/W}$
$\Theta_{JC}$	Thermal resistance (junction to case)		23.45	16.03	$^\circ\text{C/W}$

## AC Test Loads and Waveforms

Figure 3. AC Test Loads and Waveforms

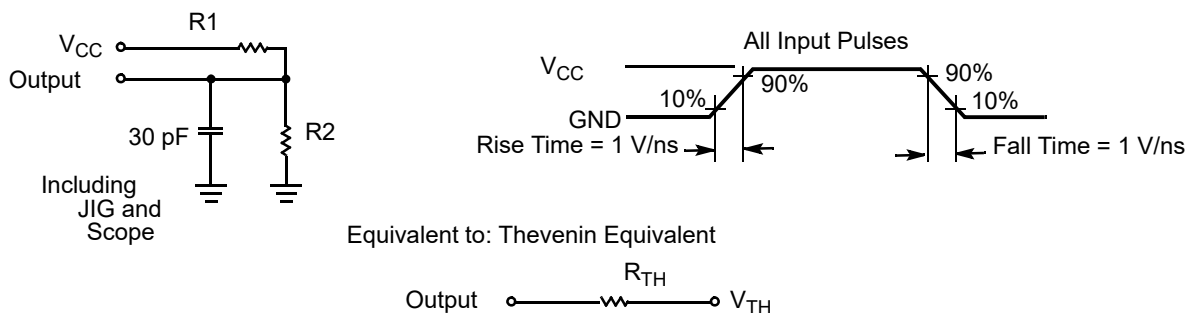

Parameter	2.50 V	3.0 V	Unit
R1	16667	1103	$\Omega$
R2	15385	1554	$\Omega$
$R_{TH}$	8000	645	$\Omega$
$V_{TH}$	1.20	1.75	V

### Note

9. Tested initially and after any design or process changes that may affect these parameters.

## Data Retention Characteristics

Over the Operating Range

Parameter	Description	Conditions	Min	Typ <sup>[10]</sup>	Max	Unit
$V_{DR}$	$V_{CC}$ for data retention		1.5	–	–	V
$I_{CCDR}$ <sup>[11]</sup>	Data retention current	$V_{CC} = 1.5\text{ V}$ , $\overline{CE} \geq V_{CC} - 0.2\text{ V}$ , $V_{IN} \geq V_{CC} - 0.2\text{ V}$ or $V_{IN} \leq 0.2\text{ V}$	–	3	8.8	$\mu\text{A}$
$t_{CDR}$ <sup>[12]</sup>	Chip deselect to data retention time	–	0	–	–	ns
$t_R$ <sup>[13]</sup>	Operation recovery time	–	45	–	–	ns

## Data Retention Waveform

Figure 4. Data Retention Waveform

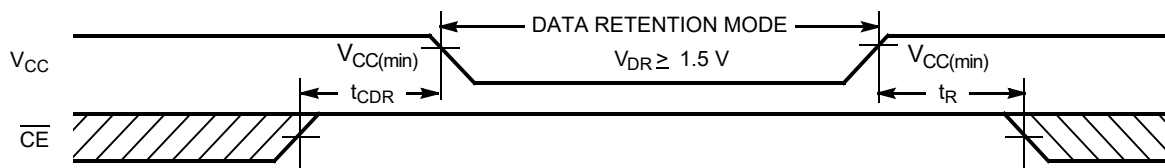

### Notes

10. Typical values are included for reference only and are not guaranteed or tested. Typical values are measured at  $V_{CC} = V_{CC(typ)}$ ,  $T_A = 25\text{ }^\circ\text{C}$ .
11. Chip enable (CE) and byte enables (BHE and BLE) need to be tied to CMOS levels to meet the  $I_{SB1}/I_{SB2}/I_{CCDR}$  spec. Other inputs can be left floating.
12. Tested initially and after any design or process changes that may affect these parameters.
13. Full device operation requires linear  $V_{CC}$  ramp from  $V_{DR}$  to  $V_{CC(min)} \geq 100\text{ }\mu\text{s}$  or stable at  $V_{CC(min)} \geq 100\text{ }\mu\text{s}$ .



## Switching Characteristics

Over the Operating Range

Parameter <sup>[14, 15]</sup>	Description	45 ns (Industrial/Automotive-A)		Unit
		Min	Max	
<b>Read Cycle</b>				
$t_{RC}$	Read cycle time	45	–	ns
$t_{AA}$	Address to data valid	–	45	ns
$t_{OHA}$	Data hold from address change	10	–	ns
$t_{ACE}$	$\overline{CE}$ LOW to data valid	–	45	ns
$t_{DOE}$	$\overline{OE}$ LOW to data valid	–	22	ns
$t_{LZOE}$	$\overline{OE}$ LOW to Low-Z <sup>[16]</sup>	5	–	ns
$t_{HZOE}$	$\overline{OE}$ HIGH to High-Z <sup>[16, 17]</sup>	–	18	ns
$t_{LZCE}$	$\overline{CE}$ LOW to Low-Z <sup>[16]</sup>	10	–	ns
$t_{HZCE}$	$\overline{CE}$ HIGH to High-Z <sup>[16, 17]</sup>	–	18	ns
$t_{PU}$	$\overline{CE}$ LOW to power up	0	–	ns
$t_{PD}$	$\overline{CE}$ HIGH to power down	–	45	ns
$t_{DBE}$	$\overline{BLE} / \overline{BHE}$ LOW to data valid	–	22	ns
$t_{LZBE}$	$\overline{BLE} / \overline{BHE}$ LOW to Low-Z <sup>[16]</sup>	5	–	ns
$t_{HZBE}$	$\overline{BLE} / \overline{BHE}$ HIGH to High-Z <sup>[16, 17]</sup>	–	18	ns
<b>Write Cycle</b> <sup>[18, 19]</sup>				
$t_{WC}$	Write cycle time	45	–	ns
$t_{SCE}$	$\overline{CE}$ LOW to write end	35	–	ns
$t_{AW}$	Address setup to write end	35	–	ns
$t_{HA}$	Address hold from write end	0	–	ns
$t_{SA}$	Address setup to write start	0	–	ns
$t_{PWE}$	$\overline{WE}$ pulse width	35	–	ns
$t_{BW}$	$\overline{BLE} / \overline{BHE}$ LOW to write end	35	–	ns
$t_{SD}$	Data setup to write end	25	–	ns
$t_{HD}$	Data hold from write end	0	–	ns
$t_{HZWE}$	$\overline{WE}$ LOW to High-Z <sup>[16, 17]</sup>	–	18	ns
$t_{LZWE}$	$\overline{WE}$ HIGH to Low-Z <sup>[16]</sup>	10	–	ns

### Notes

- Test conditions for all parameters other than tri-state parameters assume signal transition time of 3 ns (1 V/ns) or less, timing reference levels of  $V_{CC(typ)}/2$ , input pulse levels of 0 to  $V_{CC(typ)}$ , and output loading of the specified  $I_{OL}/I_{OH}$  as shown in the [Figure 3 on page 5](#).
- In an earlier revision of this device, under a specific application condition, READ and WRITE operations were limited to switching of the byte enable and/or chip enable signals as described in the Application Notes [AN13842](#) and [AN66311](#). However, the issue has been fixed and in production now, and hence, these Application Notes are no longer applicable. They are available for download on our website as they contain information on the date code of the parts, beyond which the fix has been in production.
- At any given temperature and voltage condition,  $t_{HZCE}$  is less than  $t_{LZCE}$ ,  $t_{HZBE}$  is less than  $t_{LZBE}$ ,  $t_{HZOE}$  is less than  $t_{LZOE}$ , and  $t_{HZWE}$  is less than  $t_{LZWE}$  for any given device.
- $t_{HZOE}$ ,  $t_{HZCE}$ ,  $t_{HZBE}$ , and  $t_{HZWE}$  transitions are measured when the outputs enter a high impedance state.
- The internal write time of the memory is defined by the overlap of  $\overline{WE}$ ,  $\overline{CE} = V_{IL}$ ,  $\overline{BHE}$  and/or  $\overline{BLE} = V_{IL}$ . All signals must be ACTIVE to initiate a write and any of these signals can terminate a write by going INACTIVE. The data input setup and hold timing must be referenced to the edge of the signal that terminates the write.
- The minimum write pulse width for Write Cycle No. 3 ( $\overline{WE}$  Controlled,  $\overline{OE}$  LOW) should be sum of  $t_{HZWE}$  and  $t_{SD}$ .

## Switching Waveforms

Figure 5. Read Cycle 1 (Address Transition Controlled) [20, 21]

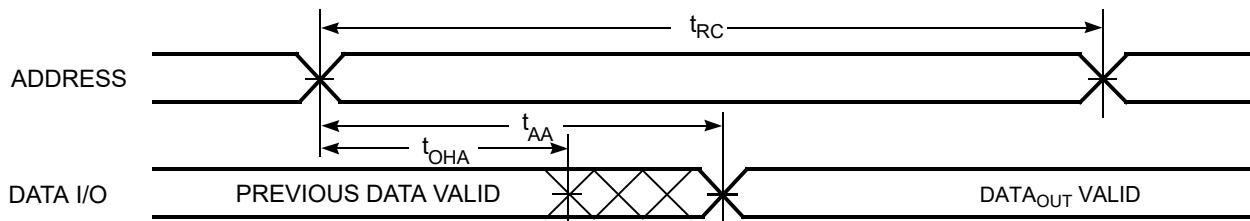
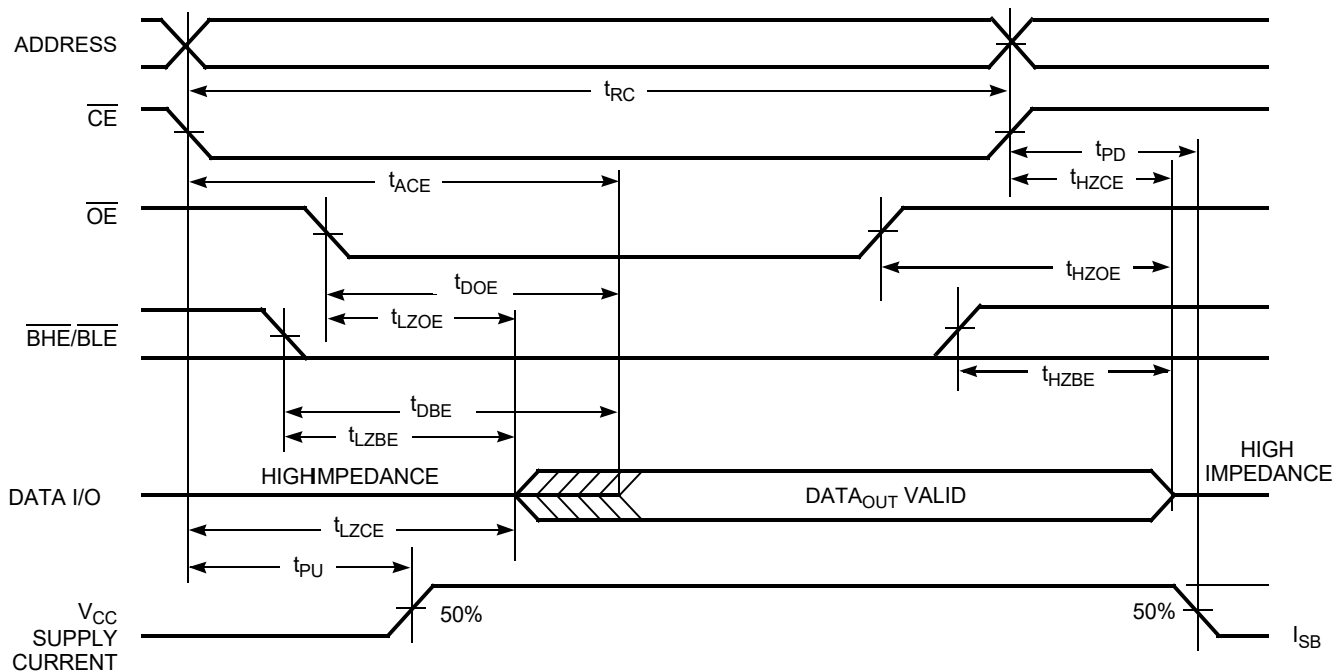

Figure 6. Read Cycle No. 2 ( $\overline{\text{OE}}$  Controlled) [21, 22]



### Notes

20. The device is continuously selected.  $\overline{\text{OE}}$ ,  $\overline{\text{CE}} = V_{\text{IL}}$ ,  $\overline{\text{BHE}}$  and/or  $\overline{\text{BLE}} = V_{\text{IL}}$ .

21.  $\overline{\text{WE}}$  is HIGH for read cycle.

22. Address valid before or similar to  $\overline{\text{CE}}$  and  $\overline{\text{BHE}}$ ,  $\overline{\text{BLE}}$  transition LOW.

## Switching Waveforms (continued)

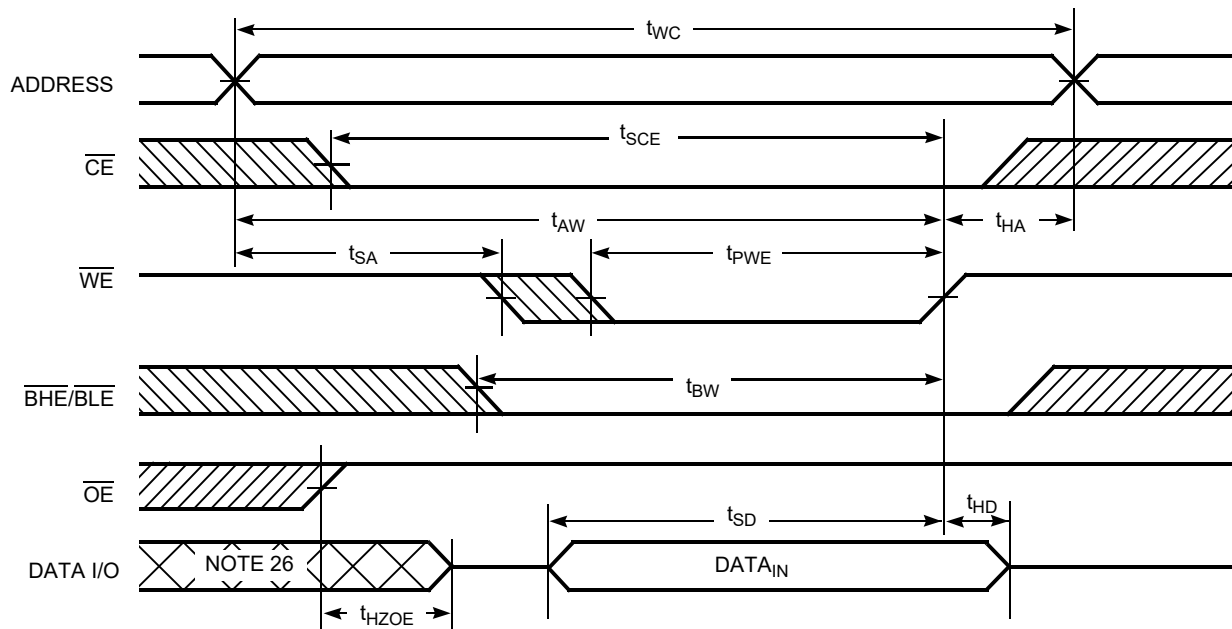
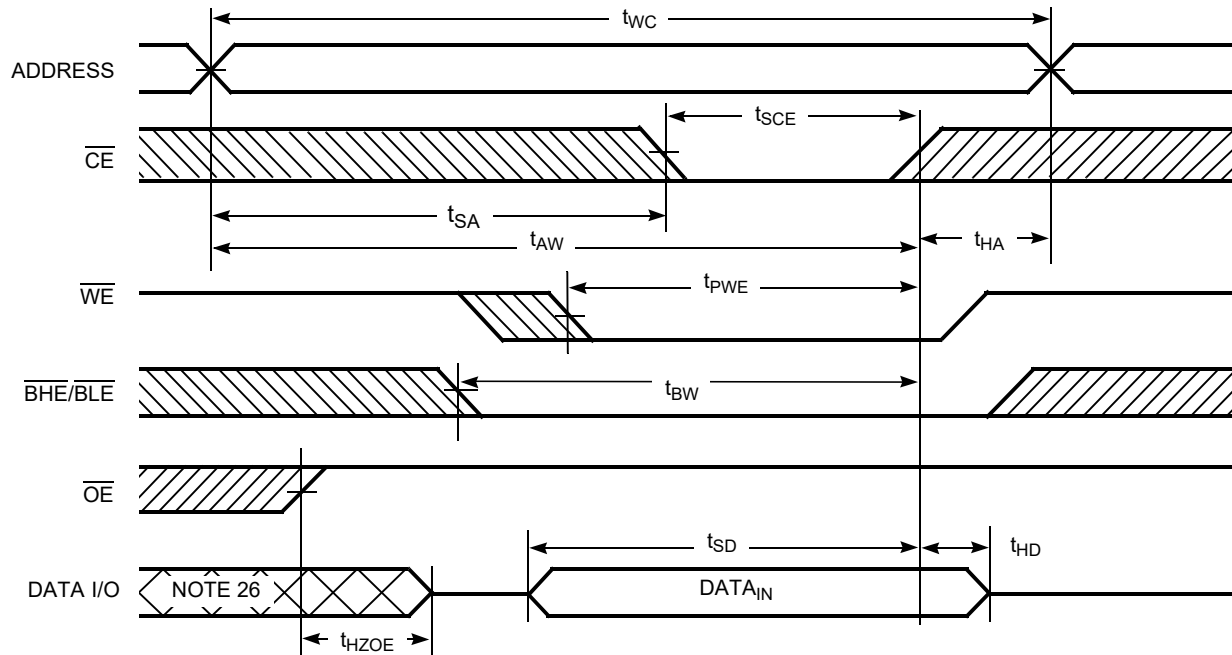
Figure 7. Write Cycle No. 1 ( $\overline{\text{WE}}$  Controlled) [23, 24, 25]Figure 8. Write Cycle No. 2 ( $\overline{\text{CE}}$  Controlled) [23, 24, 25]

## Notes

23. The internal write time of the memory is defined by the overlap of  $\overline{\text{WE}}$ ,  $\overline{\text{CE}} = V_{\text{IL}}$ ,  $\overline{\text{BHE}}$  and/or  $\overline{\text{BLE}} = V_{\text{IL}}$ . All signals must be ACTIVE to initiate a write and any of these signals can terminate a write by going INACTIVE. The data input setup and hold timing must be referenced to the edge of the signal that terminates the write.

24. Data I/O is high impedance if  $\overline{\text{OE}} = V_{\text{IH}}$ .

25. If  $\overline{\text{CE}}$  goes HIGH simultaneously with  $\overline{\text{WE}} = V_{\text{IH}}$ , the output remains in a high impedance state.

26. During this period, the I/Os are in output state and input signals must not be applied.

## Switching Waveforms (continued)

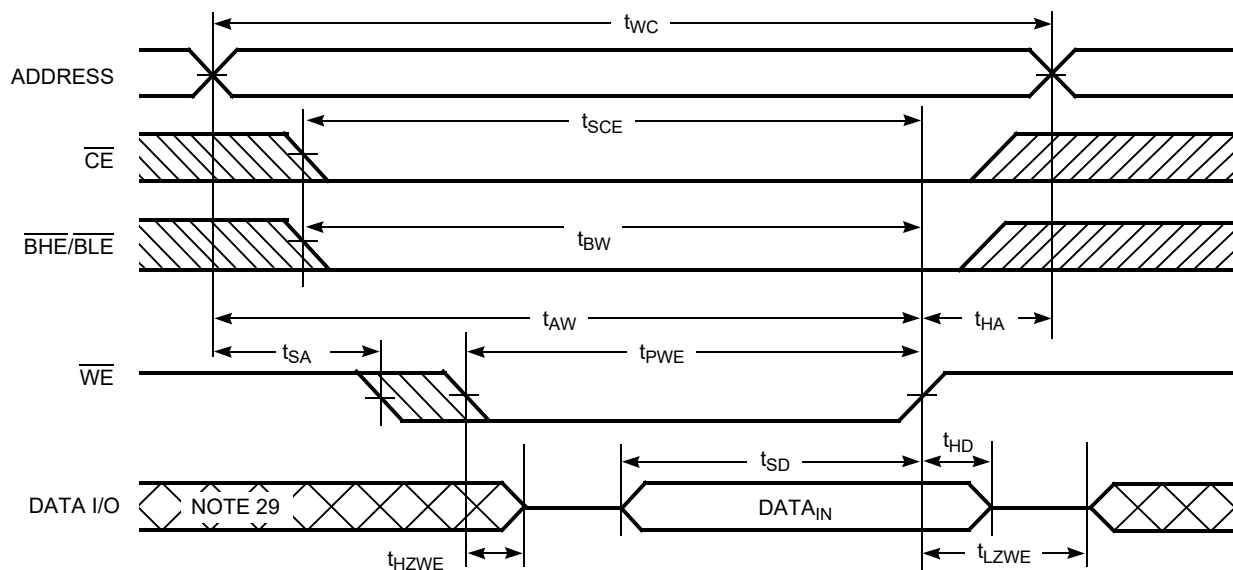
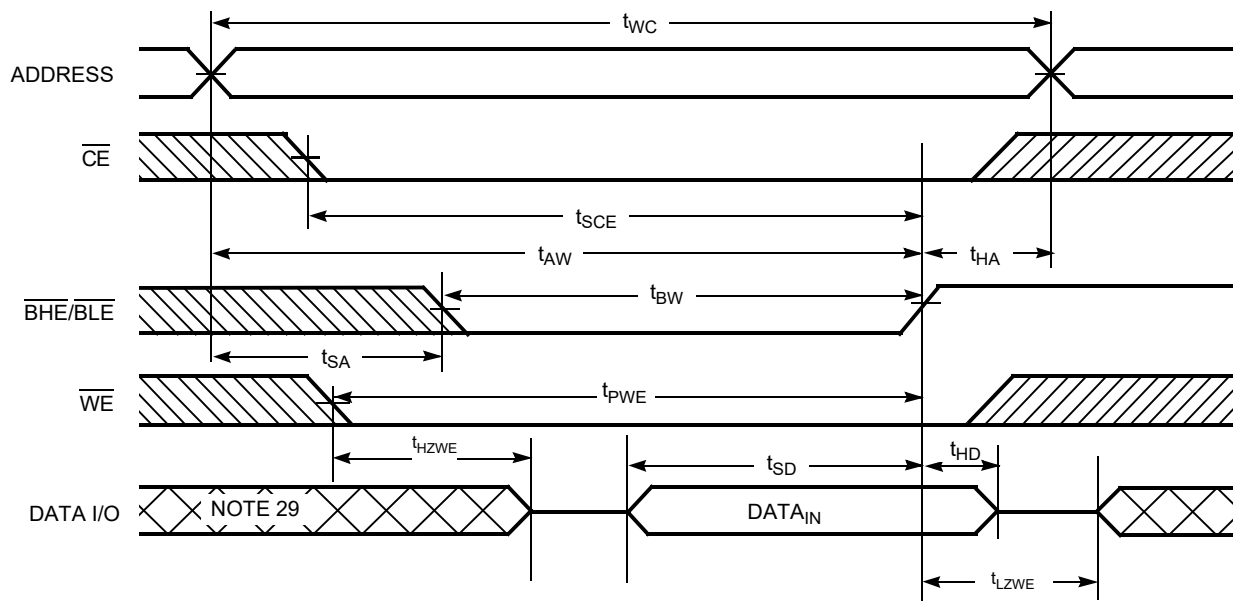
Figure 9. Write Cycle No. 3 ( $\overline{WE}$  Controlled,  $\overline{OE}$  LOW) [27, 28]Figure 10. Write Cycle No. 4 ( $\overline{BHE/BLE}$  Controlled,  $\overline{OE}$  LOW) [27]

## Notes

27. If  $\overline{CE}$  goes HIGH simultaneously with  $\overline{WE} = V_{IH}$ , the output remains in a high impedance state.

28. The minimum write pulse width for Write Cycle No. 3 ( $\overline{WE}$  Controlled,  $\overline{OE}$  LOW) should be sum of  $t_{HZWE}$  and  $t_{SD}$ .

29. During this period, the I/Os are in output state and input signals must not be applied.



## Truth Table

$\overline{CE}$ <sup>[30]</sup>	$\overline{WE}$	$\overline{OE}$	$\overline{BHE}$	$\overline{BLE}$	Inputs/Outputs	Mode	Power
H	X	X	X	X	High-Z	Deselect/power-down	Standby ( $I_{SB}$ )
L	X	X	H	H	High-Z	Output disabled	Active ( $I_{CC}$ )
L	H	L	L	L	Data out ( $I/O_0$ – $I/O_{15}$ )	Read	Active ( $I_{CC}$ )
L	H	L	H	L	Data out ( $I/O_0$ – $I/O_7$ ); $I/O_8$ – $I/O_{15}$ in High-Z	Read	Active ( $I_{CC}$ )
L	H	L	L	H	Data out ( $I/O_8$ – $I/O_{15}$ ); $I/O_0$ – $I/O_7$ in High-Z	Read	Active ( $I_{CC}$ )
L	H	H	L	L	High-Z	Output disabled	Active ( $I_{CC}$ )
L	H	H	H	L	High-Z	Output disabled	Active ( $I_{CC}$ )
L	H	H	L	H	High-Z	Output disabled	Active ( $I_{CC}$ )
L	L	X	L	L	Data in ( $I/O_0$ – $I/O_{15}$ )	Write	Active ( $I_{CC}$ )
L	L	X	H	L	Data in ( $I/O_0$ – $I/O_7$ ); $I/O_8$ – $I/O_{15}$ in High-Z	Write	Active ( $I_{CC}$ )
L	L	X	L	H	Data in ( $I/O_8$ – $I/O_{15}$ ); $I/O_0$ – $I/O_7$ in High-Z	Write	Active ( $I_{CC}$ )

### Note

30. Chip enable must be at CMOS levels (not floating). Intermediate voltage levels on this pin is not permitted.



## Ordering Information

Speed (ns)	Ordering Code	Package Diagram	Package Type	Operating Range
45	CY62146EV30LL-45BVXI	51-85150	48-ball VFBGA (Pb-free)	Industrial
	CY62146EV30LL-45ZSXI	51-85087	44-pin TSOP II (Pb-free)	

Please contact your local Cypress sales representative for availability of other parts

## Ordering Code Definitions

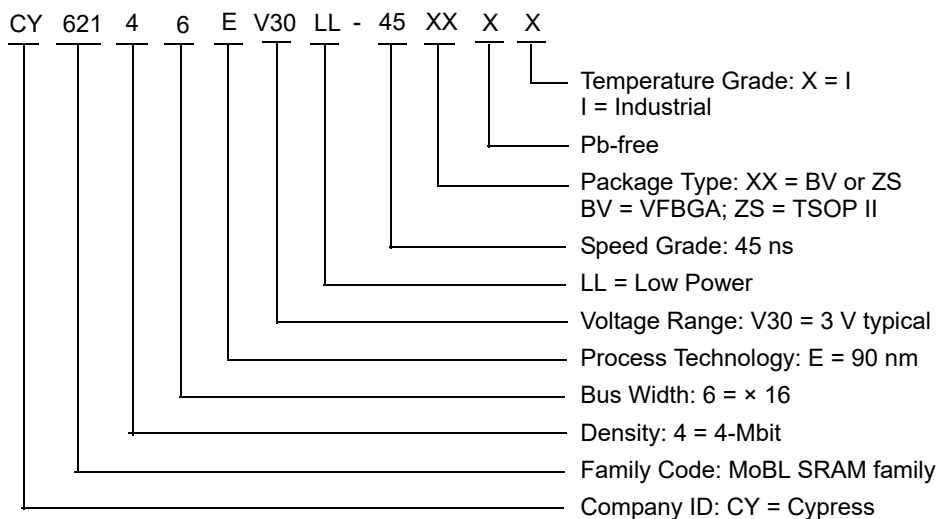

Package Diagrams

Figure 11. 48-ball VFBGA (6 × 8 × 1.0 mm) Package Outline, 51-85150

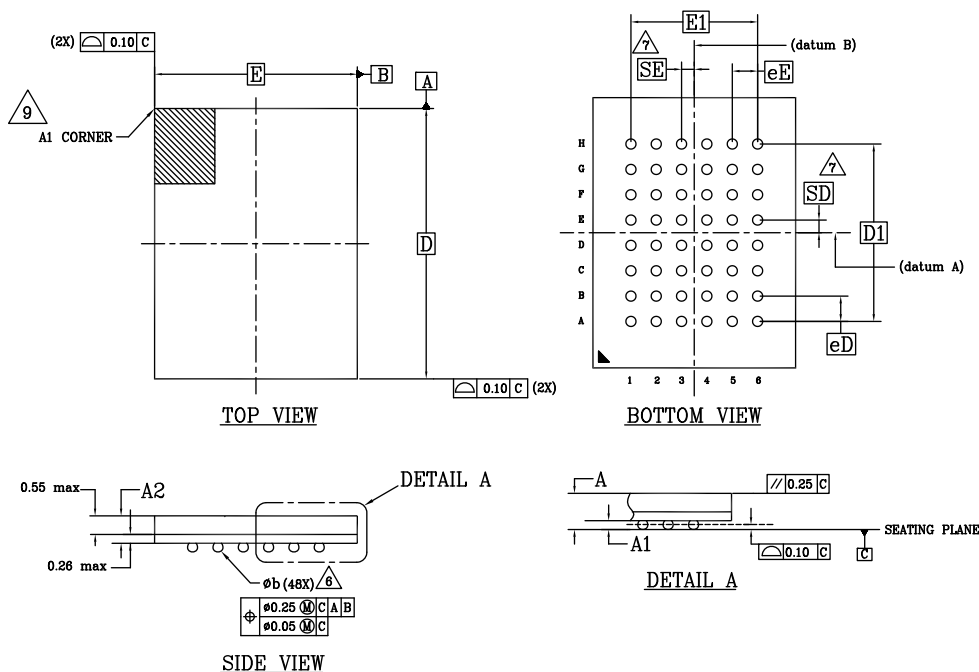

SYMBOL	DIMENSIONS		
	MIN.	NOM.	MAX.
A	-	-	1.00
A1	0.16	-	-
A2	-	-	0.81
D	8.00 BSC		
E	6.00 BSC		
D1	5.25 BSC		
E1	3.75 BSC		
MD	8		
ME	6		
n	48		
∅ b	0.25	0.30	0.35
eE	0.75 BSC		
eD	0.75 BSC		
SD	0.375 BSC		
SE	0.375 BSC		

NOTES:

1. DIMENSIONING AND TOLERANCING METHODS PER ASME Y14.5M-2009.
2. ALL DIMENSIONS ARE IN MILLIMETERS.
3. BALL POSITION DESIGNATION PER JEP95, SECTION 3, SPP-020.
4. [E] REPRESENTS THE SOLDER BALL GRID PITCH.
5. SYMBOL "MD" IS THE BALL MATRIX SIZE IN THE "D" DIRECTION, SYMBOL "ME" IS THE BALL MATRIX SIZE IN THE "E" DIRECTION, n IS THE NUMBER OF POPULATED SOLDER BALL POSITIONS FOR MATRIX SIZE MD X ME.

6. DIMENSION "b" IS MEASURED AT THE MAXIMUM BALL DIAMETER IN A PLANE PARALLEL TO DATUM C.
7. "SD" AND "SE" ARE MEASURED WITH RESPECT TO DATUMS A AND B AND DEFINE THE POSITION OF THE CENTER SOLDER BALL IN THE OUTER ROW. WHEN THERE IS AN ODD NUMBER OF SOLDER BALLS IN THE OUTER ROW "SD" OR "SE" = 0. WHEN THERE IS AN EVEN NUMBER OF SOLDER BALLS IN THE OUTER ROW, "SD" = eD/2 AND "SE" = eE/2.
8. "\*" INDICATES THE THEORETICAL CENTER OF DEPOPULATED BALLS.
9. A1 CORNER TO BE IDENTIFIED BY CHAMFER, LASER OR INK MARK METALIZED MARK, INDENTATION OR OTHER MEANS.

51-85150 \*1



Package Diagrams (continued)

Figure 12. 44-pin TSOP II (18.4 × 10.2 × 1.194 mm) Package Outline, 51-85087

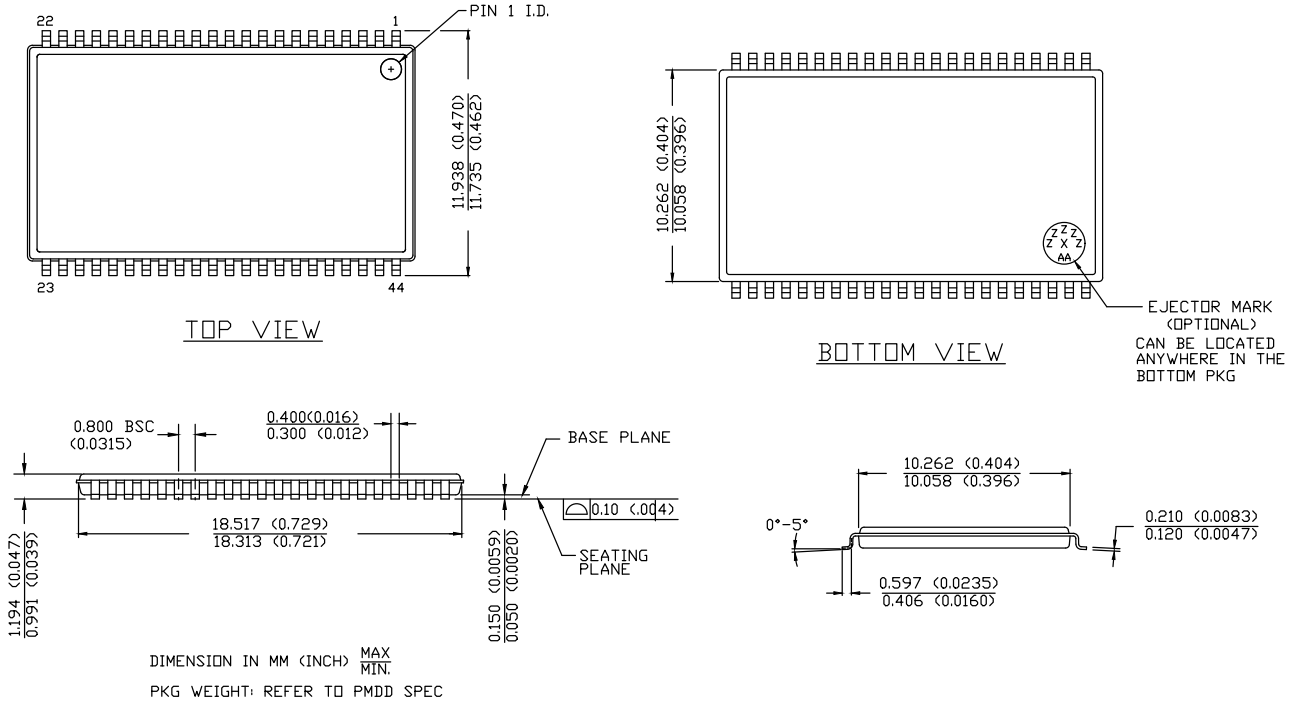

51-85087 \*F



## Acronyms

Acronym	Description
$\overline{\text{BHE}}$	Byte High Enable
$\overline{\text{BLE}}$	Byte Low Enable
CMOS	Complementary Metal Oxide Semiconductor
$\overline{\text{CE}}$	Chip Enable
I/O	Input/Output
$\overline{\text{OE}}$	Output Enable
SRAM	Static Random Access Memory
TSOP	Thin Small Outline Package
VFBGA	Very Fine-Pitch Ball Grid Array
$\overline{\text{WE}}$	Write Enable

## Document Conventions

### Units of Measure

Symbol	Unit of Measure
$^{\circ}\text{C}$	degree Celsius
MHz	megahertz
$\mu\text{A}$	microampere
mA	milliampere
ns	nanosecond
$\Omega$	ohm
pF	picofarad
V	volt
W	watt



## Document History Page

Document Title: CY62146EV30 MoBL, 4-Mbit (256K × 16) Static RAM Document Number: 38-05567			
Rev.	ECN No.	Submission Date	Description of Change
**	223225	05/05/2004	New data sheet.
*A	247373	07/28/2004	<p>Changed status from Advance Information to Preliminary.</p> <p>Updated <a href="#">Operating Range</a>:</p> <p>Updated Note 6 (Replaced “100 μs wait time” with “200 μs wait time”).</p> <p>Updated <a href="#">Data Retention Characteristics</a>:</p> <p>Changed maximum value of I<sub>CCDR</sub> parameter from 2.0 μA to 2.5 μA.</p> <p>Changed minimum value of t<sub>R</sub> parameter from 100 μs to t<sub>RC</sub> ns.</p> <p>Updated <a href="#">Switching Characteristics</a>:</p> <p>Changed minimum value of t<sub>OHA</sub> parameter from 6 ns to 10 ns corresponding to both 35 ns and 45 ns speed bin.</p> <p>Changed maximum value of t<sub>DOE</sub> parameter from 15 ns to 18 ns corresponding to 35 ns speed bin.</p> <p>Changed maximum value of t<sub>HZOE</sub>, t<sub>HZBE</sub>, and t<sub>HZWE</sub> parameters from 12 ns to 15 ns corresponding 35 ns speed bin and from 15 ns to 18 ns corresponding to 45 ns speed bin.</p> <p>Changed maximum value of t<sub>HZCE</sub> parameter from 12 ns to 18 ns corresponding to 35 ns speed bin and from 15 ns to 22 ns corresponding to 45 ns speed bin.</p> <p>Changed maximum value of t<sub>DBE</sub> parameter from 15 ns to 18 ns corresponding to 35 ns speed bin.</p> <p>Changed minimum value of t<sub>SCE</sub> and t<sub>BW</sub> parameters from 25 to 30 ns corresponding to 35 ns speed bin and from 40 ns to 35 ns corresponding to 45 ns speed bin.</p> <p>Changed minimum value of t<sub>SD</sub> parameter from 15 ns to 18 ns corresponding to 35 ns speed bin and from 20 ns to 22 ns corresponding to 45 ns speed bin.</p> <p>Removed Note “If both Byte Enables (BHE and BLE) are toggled together then this value is 6 ns min. Otherwise this value is 3 ns min.” and its reference in t<sub>LZBE</sub> parameter.</p> <p>Updated <a href="#">Ordering Information</a>:</p> <p>Updated part numbers.</p>
*B	414807	12/16/2005	<p>Changed status from Preliminary to Final.</p> <p>Removed “L” version of CY62146EV30 part in all instances across the document.</p> <p>Removed 35 ns speed bin related information in all instances across the document.</p> <p>Changed the address of Cypress Semiconductor Corporation in Page 1 from “3901 North First Street” to “198 Champion Court”.</p> <p>Updated <a href="#">Pin Configurations</a>:</p> <p>Updated <a href="#">Figure 1</a> (Replaced DNU with NC corresponding to ball E3).</p> <p>Removed Note “DNU pins have to be left floating or tied to V<sub>SS</sub> to ensure proper application.” and its reference.</p> <p>Updated <a href="#">Electrical Characteristics</a>:</p> <p>Changed typical value of I<sub>CC</sub> parameter from 12 mA to 15 mA corresponding to 45 ns speed bin and Test Condition “f = f<sub>max</sub>”.</p> <p>Changed typical value of I<sub>CC</sub> parameter from 1.5 mA to 2 mA corresponding to 45 ns speed bin and Test Condition “f = 1 MHz”.</p> <p>Changed maximum value of I<sub>CC</sub> parameter from 2 mA to 2.5 mA corresponding to 45 ns speed bin and Test Condition “f = 1 MHz”.</p> <p>Changed typical value of I<sub>SB1</sub> parameter from 0.7 μA to 1 μA corresponding to 45 ns speed bin.</p> <p>Changed maximum value of I<sub>SB1</sub> parameter from 2.5 μA to 7 μA corresponding to 45 ns speed bin.</p> <p>Changed typical value of I<sub>SB2</sub> parameter from 0.7 μA to 1 μA corresponding to 45 ns speed bin.</p> <p>Changed maximum value of I<sub>SB2</sub> parameter from 2.5 μA to 7 μA corresponding to 45 ns speed bin.</p> <p>Updated <a href="#">AC Test Loads and Waveforms</a>:</p> <p>Updated <a href="#">Figure 3</a> (Replaced 50 pF with 30 pF).</p>



## Document History Page (continued)

Document Title: CY62146EV30 MoBL, 4-Mbit (256K × 16) Static RAM Document Number: 38-05567			
Rev.	ECN No.	Submission Date	Description of Change
*B (cont.)	414807	12/16/2005	<p>Updated <a href="#">Data Retention Characteristics</a>:            Changed maximum value of I<sub>CCDR</sub> parameter from 2.5 μA to 7 μA.            Added typical value of I<sub>CCDR</sub> parameter.</p> <p>Updated <a href="#">Switching Characteristics</a>:            Changed minimum value of t<sub>LZOE</sub> parameter from 3 ns to 5 ns corresponding to 45 ns speed bin.            Changed minimum value of t<sub>LZCE</sub> parameter from 6 ns to 10 ns corresponding to 45 ns speed bin.            Changed maximum value of t<sub>HZCE</sub> parameter from 22 ns to 18 ns corresponding to 45 ns speed bin.            Changed minimum value of t<sub>LZBE</sub> parameter from 6 ns to 5 ns corresponding to 45 ns speed bin.            Changed minimum value of t<sub>PWE</sub> parameter from 30 ns to 35 ns corresponding to 45 ns speed bin.            Changed minimum value of t<sub>SD</sub> parameter from 22 ns to 25 ns corresponding to 45 ns speed bin.            Changed minimum value of t<sub>LZWE</sub> parameter from 6 ns to 10 ns corresponding to 45 ns speed bin.</p> <p>Updated <a href="#">Ordering Information</a>:            Updated part numbers.            Removed "Package Name" column.            Added "Package Diagram" column.</p> <p>Updated <a href="#">Package Diagrams</a>:            spec 51-85150 – Changed revision from *B to *D.            Updated to new template.</p>
*C	925501	04/09/2007	<p>Updated <a href="#">Electrical Characteristics</a>:            Added Note 8 and referred the same note in I<sub>SB2</sub> parameter.</p> <p>Updated <a href="#">Data Retention Characteristics</a>:            Added Note 11 and referred the same note in I<sub>CCDR</sub> parameter.</p> <p>Updated <a href="#">Switching Characteristics</a>:            Added Note 15 and referred the same note in "Parameter" column.</p>
*D	2678796	03/25/2009	<p>Added Automotive-A Temperature Range related information in all instances across the document.            Completing Sunset Review.</p>
*E	2944332	06/04/2010	<p>Updated <a href="#">Truth Table</a>:            Added Note 30 and referred the same note in "CE" column.</p> <p>Updated <a href="#">Package Diagrams</a>:            spec 51-85150 – Changed revision from *D to *E.            spec 51-85087 – Changed revision from *A to *C.            Updated to new template.</p>
*F	3109050	12/13/2010	<p>Changed all Table Footnotes to Notes in all instances across the document.</p> <p>Updated <a href="#">Ordering Information</a>:            No change in part numbers.</p> <p>Added <a href="#">Ordering Code Definitions</a>.</p> <p>Updated <a href="#">Package Diagrams</a>:            spec 51-85150 – Changed revision from *E to *F.</p>
*G	3302915	07/14/2011	<p>Updated <a href="#">Functional Description</a>:            Removed "For best practice recommendations, refer to the Cypress application note AN1064, SRAM System Guidelines." at the end.</p> <p>Updated <a href="#">Ordering Information</a>:            No change in part numbers.</p> <p>Updated <a href="#">Ordering Code Definitions</a>.            Added <a href="#">Units of Measure</a>.            Updated to new template.</p>



## Document History Page (continued)

Document Title: CY62146EV30 MoBL, 4-Mbit (256K × 16) Static RAM Document Number: 38-05567			
Rev.	ECN No.	Submission Date	Description of Change
*H	3961126	04/10/2013	Updated <a href="#">Package Diagrams</a> : spec 51-85150 – Changed revision from *F to *H. spec 51-85087 – Changed revision from *C to *E. Completing Sunset Review.
*I	4101995	08/22/2013	Updated <a href="#">Switching Characteristics</a> : Updated Note 15. Updated to new template.
*J	4348752	04/16/2014	Updated <a href="#">Switching Characteristics</a> : Added Note 19 and referred the same note in "Write Cycle". Updated <a href="#">Switching Waveforms</a> : Added Note 28 and referred the same note in <a href="#">Figure 9</a> (for $t_{PWE}$ parameter in $\overline{WE}$ Controlled, $\overline{OE}$ LOW Write Cycle). Completing Sunset Review.
*K	4576526	11/21/2014	Updated <a href="#">Functional Description</a> : Added "For a complete list of related documentation, <a href="#">click here</a> ." at the end.
*L	5233278	04/21/2016	Updated <a href="#">Thermal Resistance</a> : Replaced "two-layer" with "four-layer" in "Test Conditions" column. Updated all values in "VFBGA" and "TSOP II" columns. Updated to new template. Completing Sunset Review.
*M	6029183	01/12/2018	Updated <a href="#">Ordering Information</a> : Updated part numbers. Updated to new template.
*N	6560465	04/29/2019	Updated <a href="#">Package Diagrams</a> : spec 51-85150 – Changed revision from *H to *I. Updated to new template. Completing Sunset Review.
*O	6906316	06/26/2020	Updated <a href="#">Features</a> : Changed value of Typical standby current from 1 $\mu$ A to 2.5 $\mu$ A. Changed value of Typical active current from 2 mA to 3.5 mA. Updated <a href="#">Product Portfolio</a> : Changed typical value of Operating $I_{CC}$ from 2 mA to 3.5 mA corresponding to "f = 1 MHz". Changed maximum value of Operating $I_{CC}$ from 2.5 mA to 6 mA corresponding to "f = 1 MHz". Changed typical value of Standby, $I_{SB2}$ from 1 $\mu$ A to 2.5 $\mu$ A. Updated <a href="#">Electrical Characteristics</a> : Changed typical value of $I_{CC}$ parameter from 2 mA to 3.5 mA corresponding to Test Condition "f = 1 MHz". Changed maximum value of $I_{CC}$ parameter from 2.5 mA to 6 mA corresponding to Test Condition "f = 1 MHz". Changed typical value of $I_{SB1}$ parameter from 1 $\mu$ A to 2.5 $\mu$ A. Changed typical value of $I_{SB2}$ parameter from 1 $\mu$ A to 2.5 $\mu$ A. Updated <a href="#">Data Retention Characteristics</a> : Changed typical value of $I_{CCDR}$ parameter from 0.8 $\mu$ A to 3 $\mu$ A. Changed maximum value of $I_{CCDR}$ parameter from 7 $\mu$ A to 8.8 $\mu$ A. Updated <a href="#">Package Diagrams</a> : spec 51-85087 – Changed revision from *E to *F. Updated to new template.



## Sales, Solutions, and Legal Information

### Worldwide Sales and Design Support

Cypress maintains a worldwide network of offices, solution centers, manufacturer's representatives, and distributors. To find the office closest to you, visit us at [Cypress Locations](#).

#### Products

Arm® Cortex® Microcontrollers	<a href="http://cypress.com/arm">cypress.com/arm</a>
Automotive	<a href="http://cypress.com/automotive">cypress.com/automotive</a>
Clocks & Buffers	<a href="http://cypress.com/clocks">cypress.com/clocks</a>
Interface	<a href="http://cypress.com/interface">cypress.com/interface</a>
Internet of Things	<a href="http://cypress.com/iot">cypress.com/iot</a>
Memory	<a href="http://cypress.com/memory">cypress.com/memory</a>
Microcontrollers	<a href="http://cypress.com/mcu">cypress.com/mcu</a>
PSoC	<a href="http://cypress.com/psoc">cypress.com/psoc</a>
Power Management ICs	<a href="http://cypress.com/pmic">cypress.com/pmic</a>
Touch Sensing	<a href="http://cypress.com/touch">cypress.com/touch</a>
USB Controllers	<a href="http://cypress.com/usb">cypress.com/usb</a>
Wireless Connectivity	<a href="http://cypress.com/wireless">cypress.com/wireless</a>

#### PSoC® Solutions

[PSoC 1](#) | [PSoC 3](#) | [PSoC 4](#) | [PSoC 5LP](#) | [PSoC 6 MCU](#)

#### Cypress Developer Community

[Community](#) | [Code Examples](#) | [Projects](#) | [Video](#) | [Blogs](#) | [Training](#) | [Components](#)

#### Technical Support

[cypress.com/support](http://cypress.com/support)

© Cypress Semiconductor Corporation, 2004–2020. This document is the property of Cypress Semiconductor Corporation and its subsidiaries ("Cypress"). This document, including any software or firmware included or referenced in this document ("Software"), is owned by Cypress under the intellectual property laws and treaties of the United States and other countries worldwide. Cypress reserves all rights under such laws and treaties and does not, except as specifically stated in this paragraph, grant any license under its patents, copyrights, trademarks, or other intellectual property rights. If the Software is not accompanied by a license agreement and you do not otherwise have a written agreement with Cypress governing the use of the Software, then Cypress hereby grants you a personal, non-exclusive, nontransferable license (without the right to sublicense) (1) under its copyright rights in the Software (a) for Software provided in source code form, to modify and reproduce the Software solely for use with Cypress hardware products, only internally within your organization, and (b) to distribute the Software in binary code form externally to end users (either directly or indirectly through resellers and distributors), solely for use on Cypress hardware product units, and (2) under those claims of Cypress's patents that are infringed by the Software (as provided by Cypress, unmodified) to make, use, distribute, and import the Software solely for use with Cypress hardware products. Any other use, reproduction, modification, translation, or compilation of the Software is prohibited.

TO THE EXTENT PERMITTED BY APPLICABLE LAW, CYPRESS MAKES NO WARRANTY OF ANY KIND, EXPRESS OR IMPLIED, WITH REGARD TO THIS DOCUMENT OR ANY SOFTWARE OR ACCOMPANYING HARDWARE, INCLUDING, BUT NOT LIMITED TO, THE IMPLIED WARRANTIES OF MERCHANTABILITY AND FITNESS FOR A PARTICULAR PURPOSE. No computing device can be absolutely secure. Therefore, despite security measures implemented in Cypress hardware or software products, Cypress shall have no liability arising out of any security breach, such as unauthorized access to or use of a Cypress product. CYPRESS DOES NOT REPRESENT, WARRANT, OR GUARANTEE THAT CYPRESS PRODUCTS, OR SYSTEMS CREATED USING CYPRESS PRODUCTS, WILL BE FREE FROM CORRUPTION, ATTACK, VIRUSES, INTERFERENCE, HACKING, DATA LOSS OR THEFT, OR OTHER SECURITY INTRUSION (collectively, "Security Breach"). Cypress disclaims any liability relating to any Security Breach, and you shall and hereby do release Cypress from any claim, damage, or other liability arising from any Security Breach. In addition, the products described in these materials may contain design defects or errors known as errata which may cause the product to deviate from published specifications. To the extent permitted by applicable law, Cypress reserves the right to make changes to this document without further notice. Cypress does not assume any liability arising out of the application or use of any product or circuit described in this document. Any information provided in this document, including any sample design information or programming code, is provided only for reference purposes. It is the responsibility of the user of this document to properly design, program, and test the functionality and safety of any application made of this information and any resulting product. "High-Risk Device" means any device or system whose failure could cause personal injury, death, or property damage. Examples of High-Risk Devices are weapons, nuclear installations, surgical implants, and other medical devices. "Critical Component" means any component of a High-Risk Device whose failure to perform can be reasonably expected to cause, directly or indirectly, the failure of the High-Risk Device, or to affect its safety or effectiveness. Cypress is not liable, in whole or in part, and you shall and hereby do release Cypress from any claim, damage, or other liability arising from any use of a Cypress product as a Critical Component in a High-Risk Device. You shall indemnify and hold Cypress, its directors, officers, employees, agents, affiliates, distributors, and assigns harmless from and against all claims, costs, damages, and expenses, arising out of any claim, including claims for product liability, personal injury or death, or property damage arising from any use of a Cypress product as a Critical Component in a High-Risk Device. Cypress products are not intended or authorized for use as a Critical Component in any High-Risk Device except to the limited extent that (i) Cypress's published data sheet for the product explicitly states Cypress has qualified the product for use in a specific High-Risk Device, or (ii) Cypress has given you advance written authorization to use the product as a Critical Component in the specific High-Risk Device and you have signed a separate indemnification agreement.

Cypress, the Cypress logo, Spansion, the Spansion logo, and combinations thereof, WICED, PSoC, CapSense, EZ-USB, F-RAM, and Traveo are trademarks or registered trademarks of Cypress in the United States and other countries. For a more complete list of Cypress trademarks, visit [cypress.com](http://cypress.com). Other names and brands may be claimed as property of their respective owners.

## OUR CERTIFICATE

DiGi provide top-quality products and perfect service for customer worldwide through standardization, technological innovation and continuous improvement. DiGi through third-party certification, we stricly control the quality of products and services. Welcome your RFQ to

Email: [Info@DiGi-Electronics.com](mailto:Info@DiGi-Electronics.com)



Tel: +00 852-30501935

RFQ Email: [Info@DiGi-Electronics.com](mailto:Info@DiGi-Electronics.com)

DiGi is a global authorized distributor of electronic components.