

CY62147EV18LL-55BVXI Datasheet



www.digi-electronics.com

<https://www.DiGi-Electronics.com>

DiGi Electronics Part Number	CY62147EV18LL-55BVXI-DG
Manufacturer	Infineon Technologies
Manufacturer Product Number	CY62147EV18LL-55BVXI
Description	IC SRAM 4MBIT PARALLEL 48VFBGA
Detailed Description	SRAM - Asynchronous Memory IC 4Mbit Parallel 55 ns 48-VFBGA (6x8)

This model CY62147EV18LL-55BVXI is available at DiGi Electronics.

DiGi Electronics offers a global database of semiconductor and electronic component datasheets.

We welcome your inquiries regarding pricing, lead time, or other product-related questions.

 [Request a Quote](#)

 [Datasheet Search](#)



Tel: +00 852-30501935

RFQ Email: Info@DiGi-Electronics.com

DiGi is a global authorized distributor of electronic components.

Purchase and inquiry

Manufacturer Product Number:

CY62147EV18LL-55BVXI

Series:

MoBL®

DiGi-Electronics Programmable:

Not Verified

Memory Format:

SRAM

Memory Size:

4Mbit

Memory Interface:

Parallel

Access Time:

55 ns

Operating Temperature:

-40°C ~ 85°C (TA)

Package / Case:

48-VFBGA

Base Product Number:

CY62147

Manufacturer:

Infineon Technologies

Product Status:

Active

Memory Type:

Volatile

Technology:

SRAM - Asynchronous

Memory Organization:

256K x 16

Write Cycle Time - Word, Page:

55ns

Voltage - Supply:

1.65V ~ 2.25V

Mounting Type:

Surface Mount

Supplier Device Package:

48-VFBGA (6x8)

Environmental & Export classification

RoHS Status:

ROHS3 Compliant

REACH Status:

REACH Unaffected

HTSUS:

8542.32.0041

Moisture Sensitivity Level (MSL):

3 (168 Hours)

ECCN:

3A991B2A



CY62147EV18 MoBL®

4-Mbit (256 K × 16) Static RAM

Features

- Very high speed: 55 ns
- Wide voltage range: 1.65 V to 2.25 V
- Pin compatible with CY62147DV18
- Ultra low standby power
 - Typical standby current: 1 μ A
 - Maximum standby current: 7 μ A
- Ultra low active power
 - Typical active current: 2 mA at f = 1 MHz
- Ultra low standby power
- Easy memory expansion with \overline{CE} and \overline{OE} features
- Automatic power down when deselected
- Complementary metal oxide semiconductor (CMOS) for optimum speed and power
- Available in a Pb-free 48-ball very fine ball grid array (VFBGA) package

Functional Description

The CY62147EV18 is a high performance CMOS static RAM organized as 256 K words by 16 bits. This device features advanced circuit design to provide ultra low active current. This

is ideal for providing More Battery Life™ (MoBL®) in portable applications such as cellular telephones. The device also has an automatic power down feature that significantly reduces power consumption when addresses are not toggling. Placing the device into standby mode reduces power consumption by more than 99% when deselected (\overline{CE} HIGH or both \overline{BLE} and \overline{BHE} are HIGH). The input and output pins (I/O_0 through I/O_{15}) are placed in a high impedance state when the device is deselected (\overline{CE} HIGH), the outputs are disabled (\overline{OE} HIGH), both the $\overline{Byte High Enable}$ and the $\overline{Byte Low Enable}$ are disabled (\overline{BHE} , \overline{BLE} HIGH), or during an active write operation (\overline{CE} LOW and \overline{WE} LOW).

To write to the device, take Chip Enable (\overline{CE}) and Write Enable (\overline{WE}) inputs LOW. If $\overline{Byte Low Enable}$ (\overline{BLE}) is LOW then data from I/O pins (I/O_0 through I/O_7) is written into the location specified on the address pins (A_0 through A_{17}). If $\overline{Byte High Enable}$ (\overline{BHE}) is LOW, then data from I/O pins (I/O_8 through I/O_{15}) is written into the location specified on the address pins (A_0 through A_{17}).

To read from the device, take Chip Enable (\overline{CE}) and Output Enable (\overline{OE}) LOW while forcing the Write Enable (\overline{WE}) HIGH. If $\overline{Byte Low Enable}$ (\overline{BLE}) is LOW, then data from the memory location specified by the address pins appears on I/O_0 to I/O_7 . If $\overline{Byte High Enable}$ (\overline{BHE}) is LOW, then data from memory appears on I/O_8 to I/O_{15} . See the Truth Table on page 11 for a complete description of read and write modes.

For a complete list of related documentation, [click here](#).

Logic Block Diagram

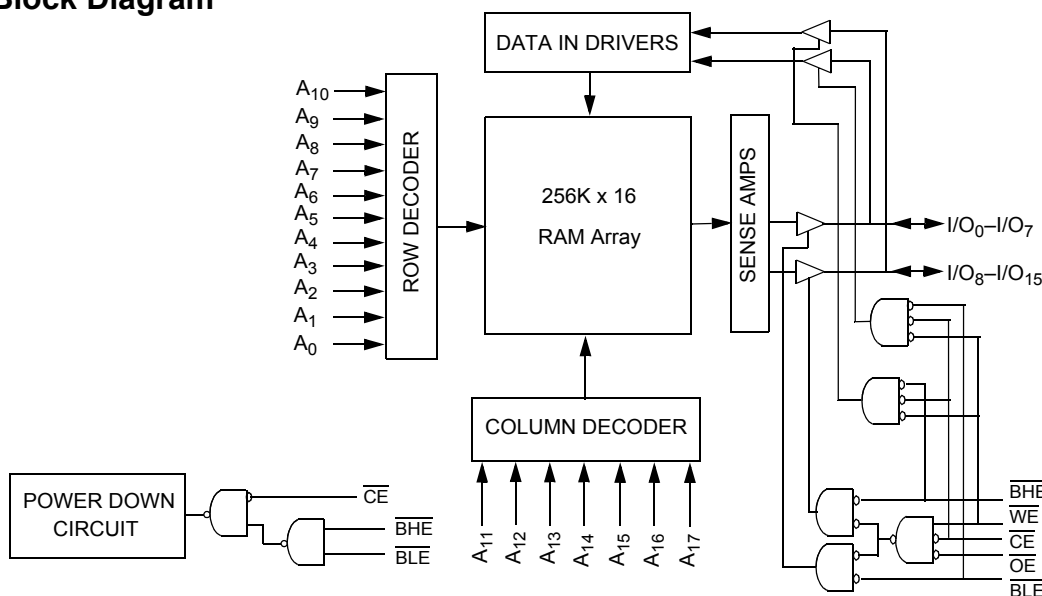



Contents

Product Portfolio	3	Ordering Information	12
Pin Configuration	3	Ordering Code Definitions	12
Maximum Ratings	4	Package Diagram	13
Operating Range	4	Acronyms	14
Electrical Characteristics	4	Document Conventions	14
Capacitance	5	Units of Measure	14
Thermal Resistance	5	Document History Page	15
AC Test Loads and Waveforms	5	Sales, Solutions, and Legal Information	17
Data Retention Characteristics	6	Worldwide Sales and Design Support	17
Data Retention Waveform	6	Products	17
Switching Characteristics	7	PSoC [®] Solutions	17
Switching Waveforms	8	Cypress Developer Community	17
Truth Table	11	Technical Support	17



Product Portfolio

Product	V _{CC} Range (V)			Speed (ns)	Power Dissipation					
					Operating I _{CC} (mA)				Standby I _{SB2} (μA)	
	f = 1MHz		f = f _{max}							
	Min	Typ ^[1]	Max		Typ ^[1]	Max	Typ ^[1]	Max	Typ ^[1]	Max
CY62147EV18LL	1.65	1.8	2.25	55	2	2.5	15	20	1	7

Pin Configuration

Figure 1. 48-ball VFBGA pinout^[2, 3]

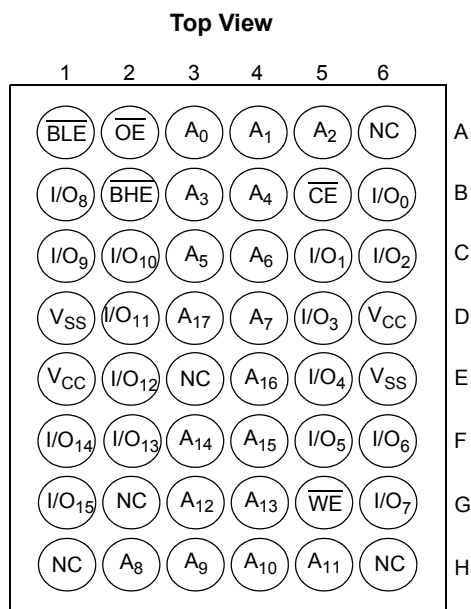

Notes

1. Typical values are included for reference only and are not guaranteed or tested. Typical values are measured at V_{CC} = V_{CC(typ)}, T_A = 25 °C
2. NC pins are not connected on the die.
3. Pins H1, G2, and H6 in the VFBGA package are address expansion pins for 8 Mb, 16 Mb and 32 Mb, respectively.



Maximum Ratings

Exceeding the maximum ratings may shorten the battery life of the device. User guidelines are not tested.

Storage temperature -65 °C to + 150 °C

Ambient temperature with power applied -55 °C to + 125 °C

Supply voltage to ground potential^[4, 5] -0.2 V to + 2.45 V ($V_{CCmax} + 0.2 V$)

DC voltage applied to outputs in High Z state^[4, 5] -0.2 V to 2.45 V ($V_{CCmax} + 0.2 V$)

DC input voltage^[4, 5] -0.2 V to 2.45 V ($V_{CCmax} + 0.2 V$)

Output current into outputs (LOW) 20 mA

Static discharge voltage (MIL-STD-883, Method 3015) > 2001 V

Latch up current > 200 mA

Operating Range

Device	Range	Ambient Temperature	V_{CC} ^[6]
CY62147EV18LL	Industrial	-40 °C to +85 °C	1.65 V to 2.25 V

Electrical Characteristics

Over the Operating Range

Parameter	Description	Test Conditions	55 ns			Unit
			Min	Typ ^[7]	Max	
V_{OH}	Output high voltage	$I_{OH} = -0.1 \text{ mA}$	1.4	–	–	V
V_{OL}	Output low voltage	$I_{OL} = 0.1 \text{ mA}$		–	0.2	V
V_{IH}	Input high voltage	$V_{CC} = 1.65 \text{ V to } 2.25 \text{ V}$	1.4	–	$V_{CC} + 0.2$	V
V_{IL}	Input low voltage	$V_{CC} = 1.65 \text{ V to } 2.25 \text{ V}$	-0.2	–	0.4	V
I_{IX}	Input leakage current	$GND \leq V_I \leq V_{CC}$	-1	–	+1	μA
I_{OZ}	Output leakage current	$GND \leq V_O \leq V_{CC}$, Output Disabled	-1	–	+1	μA
I_{CC}	V_{CC} operating supply current	$f = f_{max} = 1/t_{RC}$		15	20	mA
		$f = 1 \text{ MHz}$	$V_{CC(max)} = 2.25 \text{ V}$ $I_{OUT} = 0 \text{ mA}$ CMOS levels	–	2	2.5
I_{SB1} ^[8]	Automatic power down current – CMOS inputs	$\overline{CE} \geq V_{CC} - 0.2 \text{ V}$ or $(\overline{BHE} \text{ and } \overline{BLE}) \geq V_{CC} - 0.2 \text{ V}$, $V_{IN} \geq V_{CC} - 0.2 \text{ V}$, $V_{IN} \leq 0.2 \text{ V}$, $f = f_{max}$ (address and data only), $f = 0$ (OE, and WE), $V_{CC} = V_{CC} (max)$		1	7	μA
I_{SB2} ^[8]	Automatic power down current – CMOS inputs	$\overline{CE} \geq V_{CC} - 0.2 \text{ V}$ or $(\overline{BHE} \text{ and } \overline{BLE}) \geq V_{CC} - 0.2 \text{ V}$, $V_{IN} \geq V_{CC} - 0.2 \text{ V}$ or $V_{IN} \leq 0.2 \text{ V}$, $f = 0$, $V_{CC} = V_{CC} (max)$		1	7	μA

Notes

- $V_{IL(min)}$ = -2.0 V for pulse durations less than 20 ns.
- $V_{IH(max)}$ = $V_{CC} + 0.5 \text{ V}$ for pulse durations less than 20 ns.
- Full device AC operation assumes a minimum of 100 μs ramp time from 0 to $V_{CC(min)}$ and 200 μs wait time after V_{CC} stabilization.
- Typical values are included for reference only and are not guaranteed or tested. Typical values are measured at $V_{CC} = V_{CC(typ)}$, $T_A = 25 \text{ }^\circ\text{C}$
- Chip enable (CE) and byte enables (BHE and BLE) need to be tied to CMOS levels to meet the I_{SB1} / I_{SB2} / I_{CCDR} spec. Other inputs can be left floating.



Capacitance

Parameter ^[9]	Description	Test Conditions	Max	Unit
C _{IN}	Input capacitance	T _A = 25 °C, f = 1 MHz, V _{CC} = V _{CC(typ)}	10	pF
C _{OUT}	Output capacitance		10	pF

Thermal Resistance

Parameter ^[9]	Description	Test Conditions	VFBGA Package	Unit
Θ _{JA}	Thermal resistance (junction to ambient)	Still air, soldered on a 3 × 4.5 inch, four-layer printed circuit board	54	°C/W
Θ _{JC}	Thermal resistance (junction to case)		12	°C/W

AC Test Loads and Waveforms

Figure 2. AC Test Loads and Waveforms

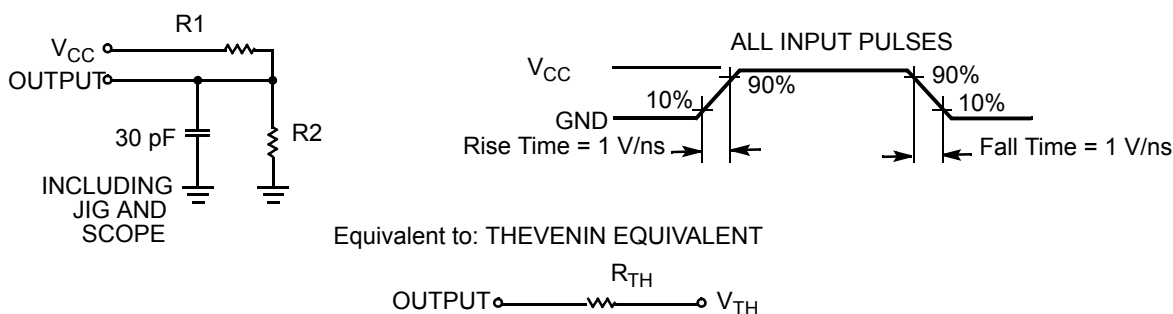

Parameters	1.80V	Unit
R1	13500	Ω
R2	10800	Ω
R _{TH}	6000	Ω
V _{TH}	0.80	V

Note

9. Tested initially and after any design or process changes that may affect these parameters.



Data Retention Characteristics

Over the Operating Range

Parameter	Description	Conditions	Min	Typ ^[10]	Max	Unit
V_{DR}	V_{CC} for data retention		1.0	–	–	V
I_{CCDR} ^[11]	Data retention current	$V_{CC} = 1.0\text{ V}$, $\overline{CE} \geq V_{CC} - 0.2\text{ V}$ or $(\overline{BHE}$ and $\overline{BLE}) \geq V_{CC} - 0.2\text{ V}$, $V_{IN} \geq V_{CC} - 0.2\text{ V}$ or $V_{IN} \leq 0.2\text{ V}$	–	0.5	5	μA
t_{CDR} ^[12]	Chip deselect to data retention time		0	–	–	ns
t_R ^[13]	Operation recovery time		55	–	–	ns

Data Retention Waveform

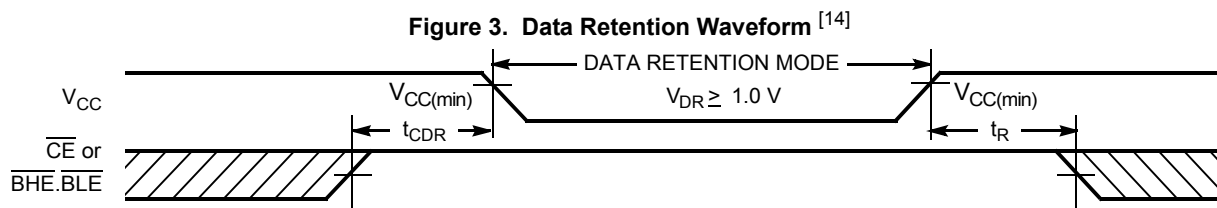

Notes

- Typical values are included for reference only and are not guaranteed or tested. Typical values are measured at $V_{CC} = V_{CC(\text{typ})}$, $T_A = 25\text{ }^\circ\text{C}$.
- Chip enable (\overline{CE}) and byte enables (\overline{BHE} and \overline{BLE}) need to be tied to CMOS levels to meet the I_{SB1} / I_{SB2} / I_{CCDR} spec. Other inputs can be left floating.
- Tested initially and after any design or process changes that may affect these parameters.
- Full device operation requires linear V_{CC} ramp from V_{DR} to $V_{CC(\text{min})} \geq 100\text{ }\mu\text{s}$ or stable at $V_{CC(\text{min})} \geq 100\text{ }\mu\text{s}$.
- $\overline{BHE.BLE}$ is the AND of both \overline{BHE} and \overline{BLE} . Deselect the chip by either disabling chip enable signals or by disabling both \overline{BHE} and \overline{BLE} .



Switching Characteristics

Over the Operating Range

Parameter ^[15,16]	Description	55 ns		Unit
		Min	Max	
Read Cycle				
t_{RC}	Read cycle time	55	–	ns
t_{AA}	Address to data valid	–	55	ns
t_{OHA}	Data hold from address change	10	–	ns
t_{ACE}	\overline{CE} LOW to data valid	–	55	ns
t_{DOE}	\overline{OE} LOW to data valid		25	ns
t_{LZOE}	\overline{OE} LOW to Low Z ^[17]	5	–	ns
t_{HZOE}	\overline{OE} HIGH to High Z ^[17, 18]	–	18	ns
t_{LZCE}	\overline{CE} LOW to Low Z ^[17]	10	–	ns
t_{HZCE}	\overline{CE} HIGH to High Z ^[17, 18]	–	18	ns
t_{PU}	\overline{CE} LOW to power up	0	–	ns
t_{PD}	\overline{CE} HIGH to power down	–	55	ns
t_{DBE}	$\overline{BLE}/\overline{BHE}$ LOW to data valid	–	55	ns
t_{LZBE}	$\overline{BLE}/\overline{BHE}$ LOW to Low Z ^[17]	10	–	ns
t_{HZBE}	$\overline{BLE}/\overline{BHE}$ HIGH to High Z ^[17, 18]	–	18	ns
Write Cycle ^[19, 20]				
t_{WC}	Write cycle time	45	–	ns
t_{SCE}	\overline{CE} LOW to write end	35	–	ns
t_{AW}	Address setup to write end	35	–	ns
t_{HA}	Address hold from write end	0	–	ns
t_{SA}	Address setup to write start	0	–	ns
t_{PWE}	\overline{WE} pulse width	35	–	ns
t_{BW}	$\overline{BLE}/\overline{BHE}$ LOW to write end	35	–	ns
t_{SD}	Data setup to write end	25	–	ns
t_{HD}	Data hold from write end	0	–	ns
t_{HZWE}	\overline{WE} LOW to High Z ^[17, 18]	–	18	ns
t_{LZWE}	\overline{WE} HIGH to Low Z ^[17]	10	–	ns

Notes

- Test conditions for all parameters other than tri-state parameters assume signal transition time of 1 V/ns or less, timing reference levels of $V_{CC(typ)}/2$, input pulse levels of 0 to $V_{CC(typ)}$, and output loading of the specified I_{OL}/I_{OH} as shown in the "AC Test Loads and Waveforms" on page 5 section
- In an earlier revision of this device, under a specific application condition, READ and WRITE operations were limited to switching of the byte enable and/or chip enable signals as described in the Application Notes AN13842 and AN66311. However, the issue has been fixed and in production now, and hence, these Application Notes are no longer applicable. They are available for download on our website as they contain information on the date code of the parts, beyond which the fix has been in production.
- At any temperature and voltage condition, t_{HZCE} is less than t_{LZCE} , t_{HZBE} is less than t_{LZBE} , t_{HZOE} is less than t_{LZOE} , and t_{HZWE} is less than t_{LZWE} for any device.
- t_{HZOE} , t_{HZCE} , t_{HZBE} , and t_{HZWE} transitions are measured when the output enters a high impedance state
- The internal write time of the memory is defined by the overlap of \overline{WE} , $\overline{CE} = V_{IL}$, \overline{BHE} , \overline{BLE} or both = V_{IL} . All signals must be active to initiate a write and any of these signals can terminate a write by going inactive. The data input setup and hold timing must be referenced to the edge of the signal that terminates the write.
- The minimum pulse width for write cycle 3 (\overline{WE} controlled, \overline{OE} LOW) should be equal to the sum of t_{SD} and t_{HZWE} .

Switching Waveforms

Figure 4. Read Cycle No. 1 (Address Transition Controlled) [21, 22]

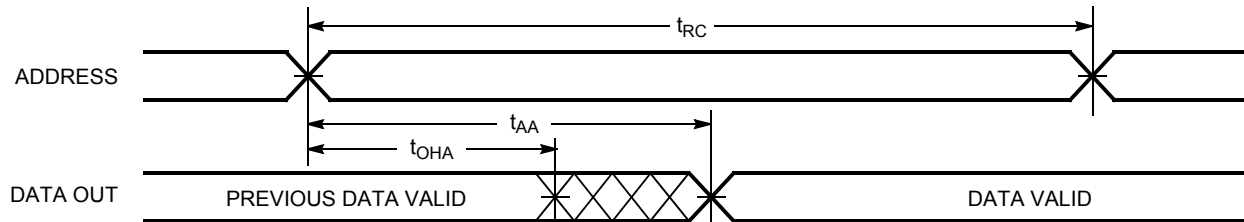
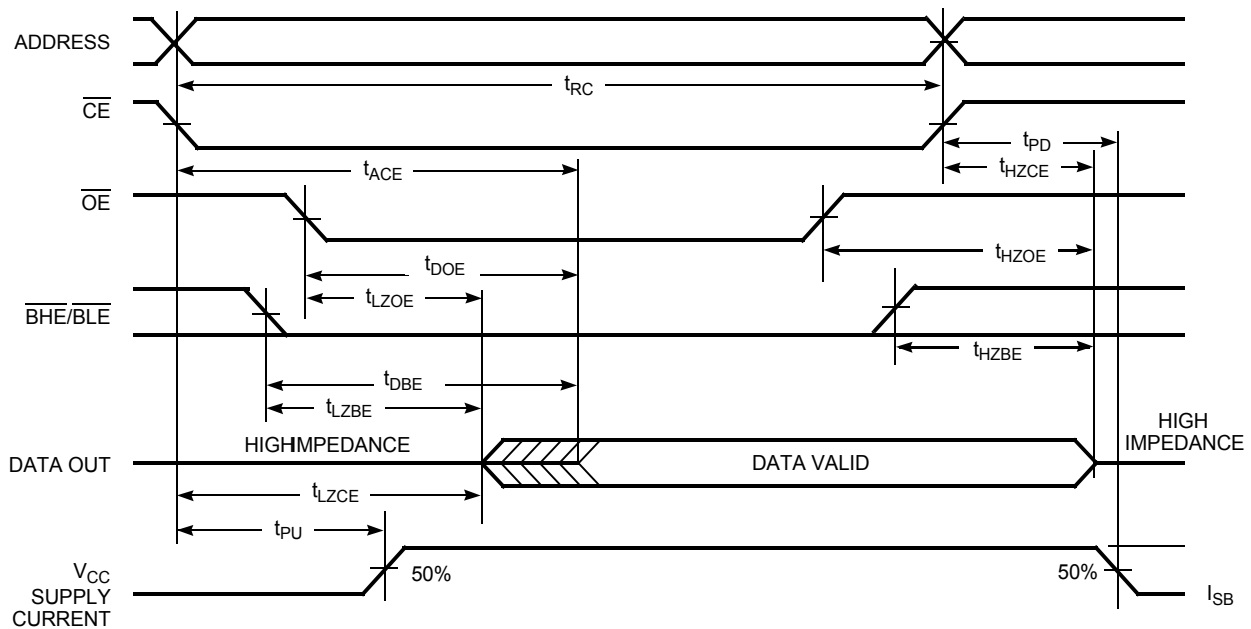

Figure 5. Read Cycle No. 2 (\overline{OE} Controlled) [22, 23]



Notes

21. The device is continuously selected. \overline{OE} , \overline{CE} = V_{IL} , \overline{BHE} , \overline{BLE} or both = V_{IL} .
22. \overline{WE} is high for read cycle.
23. Address valid before or similar to \overline{CE} and \overline{BHE} , \overline{BLE} transition low.

Switching Waveforms (continued)

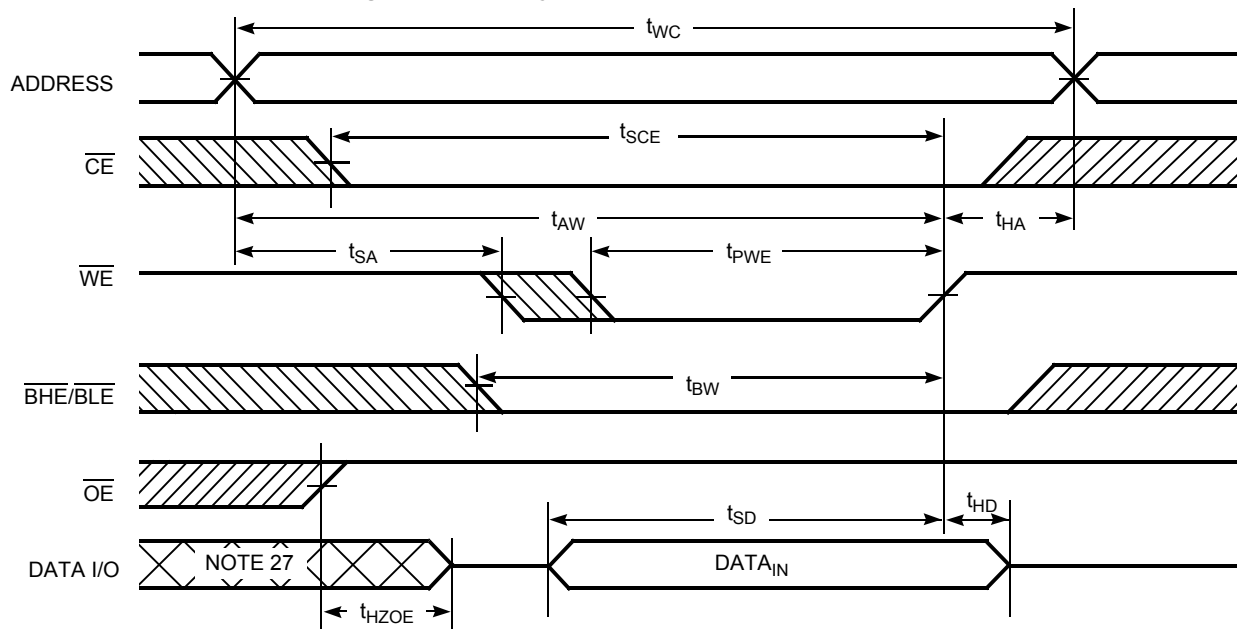
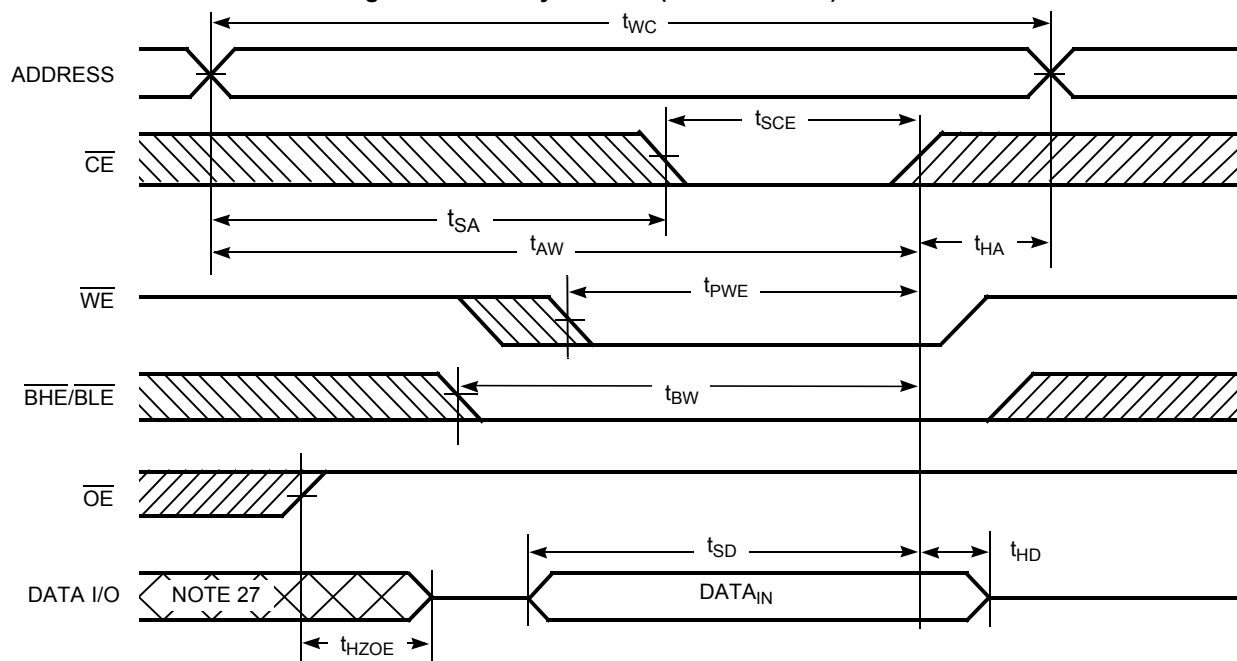
Figure 6. Write Cycle No. 1 ($\overline{\text{WE}}$ Controlled) [24, 25, 26]Figure 7. Write Cycle No. 2 ($\overline{\text{CE}}$ Controlled) [24, 25, 26]

Notes

24. $\overline{\text{BHE}}/\overline{\text{BLE}}$ is the AND of both $\overline{\text{BHE}}$ and $\overline{\text{BLE}}$. Deselect the chip by either disabling chip enable signals or by disabling both $\overline{\text{BHE}}$ and $\overline{\text{BLE}}$.

25. Data I/O is high impedance if $\text{OE} = V_{\text{IH}}$.

26. If $\overline{\text{CE}}$ goes high simultaneously with $\text{WE} = V_{\text{IH}}$, the output remains in a high impedance state.

27. During this period, the I/Os are in output state. Do not apply input signals.

Switching Waveforms (continued)

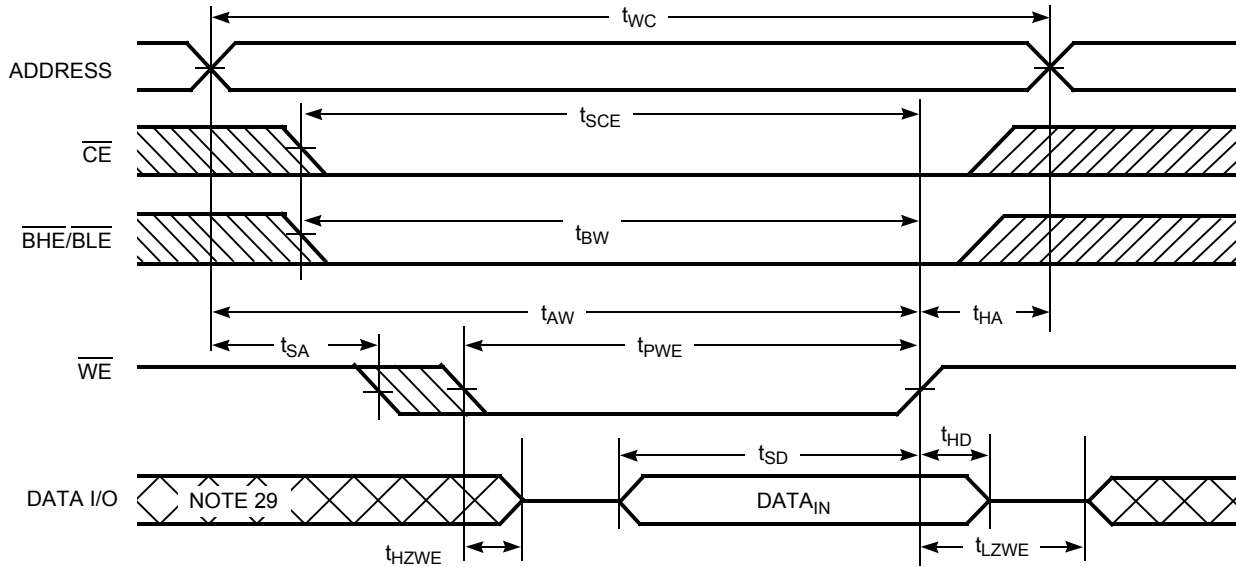
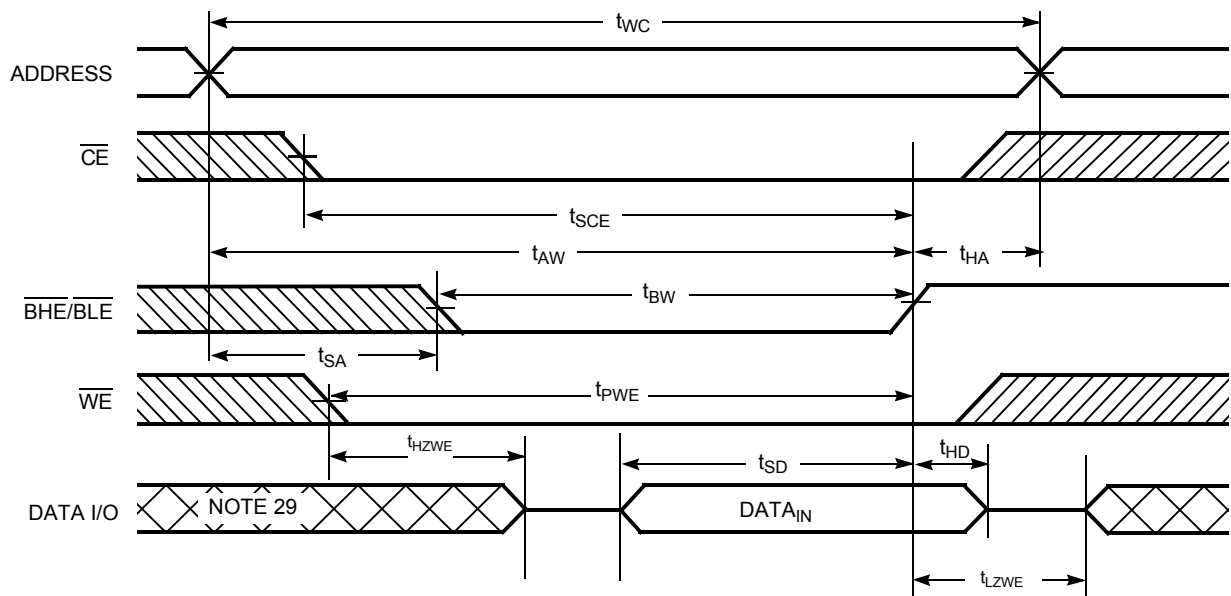
Figure 8. Write Cycle No. 3 ($\overline{\text{WE}}$ Controlled and $\overline{\text{OE}}$ LOW) [28]Figure 9. Write Cycle No. 4 ($\overline{\text{BHE/BLE}}$ Controlled and $\overline{\text{OE}}$ LOW) [28]

Notes

28. If $\overline{\text{CE}}$ goes high simultaneously with $\overline{\text{WE}} = V_{IH}$, the output remains in a high impedance state.
 29. During this period, the I/Os are in output state. Do not apply input signals.



Truth Table

\overline{CE}	\overline{WE}	\overline{OE}	\overline{BHE}	\overline{BLE}	Inputs or Outputs	Mode	Power
H	X	X	X ^[30]	X ^[30]	High-Z	Deselect or power down	Standby (I_{SB})
X ^[30]	X	X	H	H	High-Z	Deselect or power down	Standby (I_{SB})
L	H	L	L	L	Data out ($I/O_0 - I/O_{15}$)	Read	Active (I_{CC})
L	H	L	H	L	Data out ($I/O_0 - I/O_7$); $I/O_8 - I/O_{15}$ in High-Z	Read	Active (I_{CC})
L	H	L	L	H	Data out ($I/O_8 - I/O_{15}$); $I/O_0 - I/O_7$ in High-Z	Read	Active (I_{CC})
L	H	H	L	L	High-Z	Output disabled	Active (I_{CC})
L	H	H	H	L	High-Z	Output disabled	Active (I_{CC})
L	H	H	L	H	High-Z	Output disabled	Active (I_{CC})
L	L	X	L	L	Data in ($I/O_0 - I/O_{15}$)	Write	Active (I_{CC})
L	L	X	H	L	Data in ($I/O_0 - I/O_7$); $I/O_8 - I/O_{15}$ in High-Z	Write	Active (I_{CC})
L	L	X	L	H	Data in ($I/O_8 - I/O_{15}$); $I/O_0 - I/O_7$ in High-Z	Write	Active (I_{CC})

Note

30. The 'X' (Do not care) state for the Chip enable (\overline{CE}) and byte enables (\overline{BHE} and \overline{BLE}) in the truth table refer to the logic state (either high or low). Intermediate voltage levels on this pin is not permitted.



Ordering Information

Speed (ns)	Ordering Code	Package Diagram	Package Type	Operating Range
55	CY62147EV18LL-55BVXI	51-85150	48-ball VFBGA (Pb-free)	Industrial

Contact your local Cypress sales representative for availability of other parts.

Ordering Code Definitions

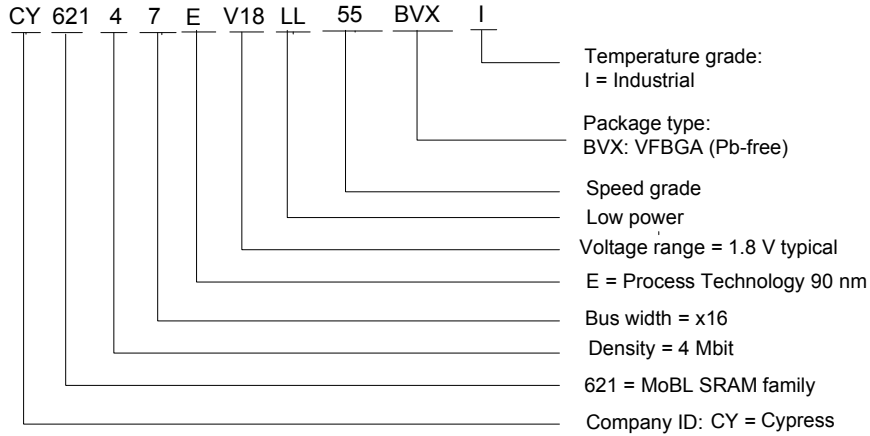



Package Diagram

Figure 10. 48-Ball VFBGA (6 × 8 × 1 mm) BV48/BZ48 Package Outline, 51-85150

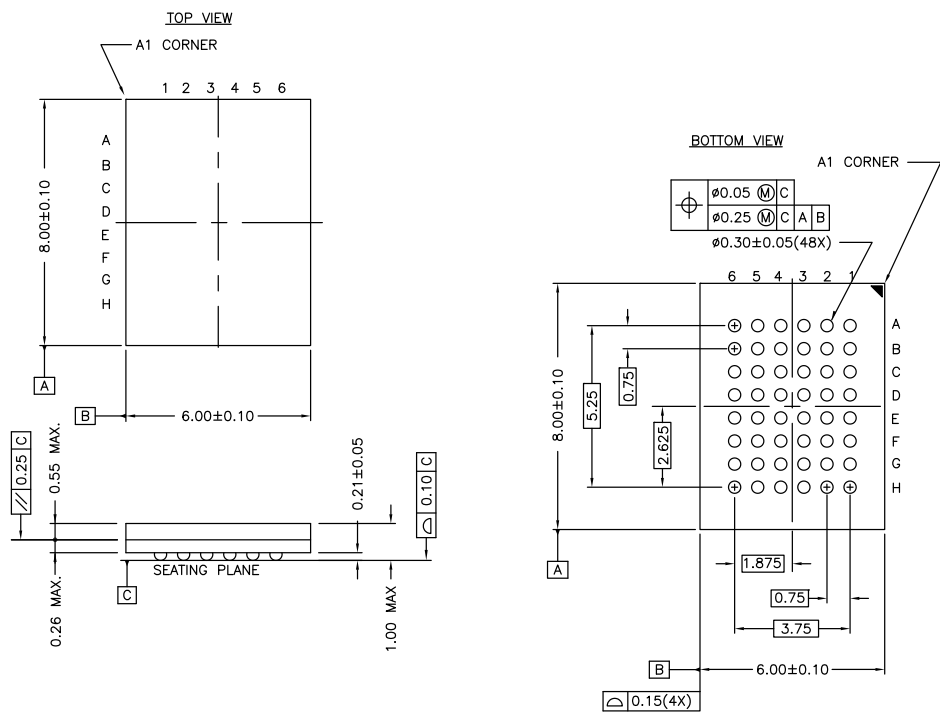

NOTE:
 PACKAGE WEIGHT: See Cypress Package Material Declaration Datasheet (PMDD) posted on the Cypress web.

51-85150 *H



Acronyms

Acronym	Description
$\overline{\text{BHE}}$	Byte High Enable
$\overline{\text{BLE}}$	Byte Low Enable
CMOS	Complementary Metal Oxide Semiconductor
$\overline{\text{CE}}$	Chip Enable
I/O	Input/Output
$\overline{\text{OE}}$	Output Enable
SRAM	Static Random Access Memory
TSOP	Thin Small Outline Package
VFBGA	Very Fine-Pitch Ball Grid Array
$\overline{\text{WE}}$	Write Enable

Document Conventions

Units of Measure

Symbol	Unit of Measure
°C	degree Celsius
MHz	megahertz
μA	microampere
mA	milliampere
ns	nanosecond
Ω	ohm
pF	picofarad
V	volt
W	watt



Document History Page

Document Title: CY62147EV18 MoBL [®] , 4-Mbit (256 K × 16) Static RAM Document Number: 38-05441				
Rev.	ECN No.	Submission Date	Orig. of Change	Description of Change
**	201580	01/08/04	AJU	New data sheet.
*A	247009	See ECN	SYT	<p>Changed status from Advance Information to Preliminary. Moved Product Portfolio to Page 2 Changed V_{CCMax} from 2.20 to 2.25 V Changed V_{CC} stabilization time in footnote #8 from 100 μs to 200 μs Removed Footnote #15 (t_{LZBE}) from Previous Revision Changed I_{CCDR} from 2.0 μA to 2.5 μA Changed typo in Data Retention Characteristics (t_R) from 100 μs to t_{RC} ns Changed t_{OHA} from 6 ns to 10 ns for both 35 ns and 45 ns Speed Bin Changed t_{HZOE}, t_{HZBE}, t_{HZWE} from 12 to 15 ns for 35 ns Speed Bin and 15 to 18 ns for 45 ns Speed Bin Changed t_{SCE} and t_{BW} from 25 to 30 ns for 35 ns Speed Bin and 40 to 35 ns for 45 ns Speed Bin Changed t_{HZCE} from 12 to 18 ns for 35 ns Speed Bin and 15 to 22 ns for 45 ns Speed Bin Changed t_{SD} from 15 to 18 ns for 35 ns Speed Bin and 20 to 22 ns for 45 ns Speed Bin Changed t_{DOE} from 15 to 18 ns for 35 ns Speed Bin Changed Ordering Information to include Pb-Free Packages</p>
*B	414820	See ECN	ZSD	<p>Changed status from Preliminary to Final Changed the address of Cypress Semiconductor Corporation on Page #1 from "3901 North First Street" to "198 Champion Court" Removed 35 ns Speed Bin Removed "L" version of CY62147EV18 Changed ball E3 from DNU to NC Changed $I_{CC}(typ)$ value from 1.5 mA to 2 mA at $f = 1$ MHz Changed $I_{CC}(max)$ value from 2 mA to 2.5 mA at $f = 1$ MHz Changed $I_{CC}(typ)$ value from 12 mA to 15 mA at $f = f_{max}$ Changed I_{SB1} and I_{SB2} Typ values from 0.7 μA to 1 μA and Max values from 2.5 μA to 7 μA Extended undershoot limit to -2 V in footnote #5 Changed I_{CCDR} Max from 2.5 μA to 3 μA Added I_{CCDR} typical value Changed t_{LZOE} from 3 ns to 5 ns Changed t_{LZCE}, t_{LZBE} and t_{LZWE} from 6 ns to 10 ns Changed t_{HZCE} from 22 ns to 18 ns Changed t_{PWE} from 30 ns to 35 ns Changed t_{SD} from 22 ns to 25 ns Updated the package diagram 48-pin VFBGA from *B to *D Updated the ordering information table and replaced Package Name Column with Package Diagram</p>
*C	571786	See ECN	VKN	Replaced 45ns speed bin with 55 ns



Document History Page (continued)

Document Title: CY62147EV18 MoBL [®] , 4-Mbit (256 K × 16) Static RAM Document Number: 38-05441				
Rev.	ECN No.	Submission Date	Orig. of Change	Description of Change
*D	908120	See ECN	VKN	Added footnote #8 related to I _{SB2} and I _{CCDR} Added footnote #13 related AC timing parameters Changed t _{WC} specification from 45 ns to 55 ns Changed t _{SCE} , t _{AW} , t _{PWE} , t _{BW} spec from 35 ns to 40 ns Changed t _{HZWE} specification from 18 ns to 20 ns
*E	1045701	See ECN	VKN	Changed I _{CCDR} specification from 3 μA to 5 μA
*F	1274728	See ECN	VKN / AESA	Changed t _{WC} specification from 55 ns to 45 ns Changed t _{SCE} , t _{AW} , t _{PWE} , t _{BW} specification from 40 ns to 35 ns Changed t _{HZWE} specification from 20 ns to 18 ns
*G	2944332	06/04/2010	VKN	Added Contents Added footnote related to chip enable in Truth Table Updated Package Diagram . Added Sales, Solutions, and Legal Information .
*H	3047228	10/06/2010	RAME	Updated and converted all table notes into footnotes. Updated Electrical Characteristics . Updated Data Retention Characteristics . Updated Package Diagram : spec 51-85150 – Changed revision from *E to *F. Added Acronyms and Units of Measure .
*I	3302815	07/29/2011	RAME	Removed AN1064 reference from the document. Updated Ordering Code Definition. Updated to new template.
*J	4102266	08/22/2013	VINI	Updated Switching Characteristics : Updated Note 16. Updated Package Diagram : spec 51-85150 – Changed revision from *F to *H. Updated to new template. Completing Sunset Review.
*K	4574264	11/19/2014	VINI	Updated Functional Description : Added “For a complete list of related documentation, click here .” at the end. Updated Maximum Ratings : Referred Notes 4 and 5 in “Supply voltage to ground potential”. Updated Switching Characteristics : Added Note 20 and referred the same note in “Write Cycle”.
*L	5023825	11/23/2015	VINI	Updated Thermal Resistance : Changed value of Θ _{JA} parameter corresponding to VFBGA Package from 75 °C/W to 54 °C/W. Changed value of Θ _{JC} parameter corresponding to VFBGA Package from 10 °C/W to 12 °C/W. Updated to new template. Completing Sunset Review.



Sales, Solutions, and Legal Information

Worldwide Sales and Design Support

Cypress maintains a worldwide network of offices, solution centers, manufacturer's representatives, and distributors. To find the office closest to you, visit us at [Cypress Locations](#).

Products

Automotive	cypress.com/go/automotive
Clocks & Buffers	cypress.com/go/clocks
Interface	cypress.com/go/interface
Lighting & Power Control	cypress.com/go/powerpsoc
Memory	cypress.com/go/memory
PSoC	cypress.com/go/psoc
Touch Sensing	cypress.com/go/touch
USB Controllers	cypress.com/go/USB
Wireless/RF	cypress.com/go/wireless

PSoC[®] Solutions

psoc.cypress.com/solutions
 PSoC 1 | PSoC 3 | PSoC 4 | PSoC 5LP

Cypress Developer Community

[Community](#) | [Forums](#) | [Blogs](#) | [Video](#) | [Training](#)

Technical Support

cypress.com/go/support

© Cypress Semiconductor Corporation, 2004-2015. The information contained herein is subject to change without notice. Cypress Semiconductor Corporation assumes no responsibility for the use of any circuitry other than circuitry embodied in a Cypress product. Nor does it convey or imply any license under patent or other rights. Cypress products are not warranted nor intended to be used for medical, life support, life saving, critical control or safety applications, unless pursuant to an express written agreement with Cypress. Furthermore, Cypress does not authorize its products for use as critical components in life-support systems where a malfunction or failure may reasonably be expected to result in significant injury to the user. The inclusion of Cypress products in life-support systems application implies that the manufacturer assumes all risk of such use and in doing so indemnifies Cypress against all charges.

Any Source Code (software and/or firmware) is owned by Cypress Semiconductor Corporation (Cypress) and is protected by and subject to worldwide patent protection (United States and foreign), United States copyright laws and international treaty provisions. Cypress hereby grants to licensee a personal, non-exclusive, non-transferable license to copy, use, modify, create derivative works of, and compile the Cypress Source Code and derivative works for the sole purpose of creating custom software and or firmware in support of licensee product to be used only in conjunction with a Cypress integrated circuit as specified in the applicable agreement. Any reproduction, modification, translation, compilation, or representation of this Source Code except as specified above is prohibited without the express written permission of Cypress.

Disclaimer: CYPRESS MAKES NO WARRANTY OF ANY KIND, EXPRESS OR IMPLIED, WITH REGARD TO THIS MATERIAL, INCLUDING, BUT NOT LIMITED TO, THE IMPLIED WARRANTIES OF MERCHANTABILITY AND FITNESS FOR A PARTICULAR PURPOSE. Cypress reserves the right to make changes without further notice to the materials described herein. Cypress does not assume any liability arising out of the application or use of any product or circuit described herein. Cypress does not authorize its products for use as critical components in life-support systems where a malfunction or failure may reasonably be expected to result in significant injury to the user. The inclusion of Cypress' product in a life-support systems application implies that the manufacturer assumes all risk of such use and in doing so indemnifies Cypress against all charges.

Use may be limited by and subject to the applicable Cypress software license agreement.

OUR CERTIFICATE

DiGi provide top-quality products and perfect service for customer worldwide through standardization, technological innovation and continuous improvement. DiGi through third-party certification, we stricly control the quality of products and services. Welcome your RFQ to

Email: Info@DiGi-Electronics.com



Tel: +00 852-30501935

RFQ Email: Info@DiGi-Electronics.com

DiGi is a global authorized distributor of electronic components.