

CY62148ELL-45ZSXIT Datasheet

www.digi-electronics.com

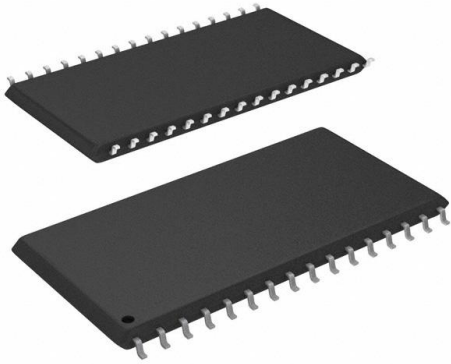

<https://www.DiGi-Electronics.com>

DiGi Electronics Part Number	CY62148ELL-45ZSXIT-DG
Manufacturer	Infineon Technologies
Manufacturer Product Number	CY62148ELL-45ZSXIT
Description	IC SRAM 4MBIT PARALLEL 32TSOP II
Detailed Description	SRAM - Asynchronous Memory IC 4Mbit Parallel 45 ns 32-TSOP II

This model CY62148ELL-45ZSXIT is available at DiGi Electronics.

DiGi Electronics offers a global database of semiconductor and electronic component datasheets.

We welcome your inquiries regarding pricing, lead time, or other product-related questions.

 [Request a Quote](#)

 [Datasheet Search](#)



Tel: +00 852-30501935

RFQ Email: Info@DiGi-Electronics.com

DiGi is a global authorized distributor of electronic components.

Purchase and inquiry

Manufacturer Product Number:

CY62148ELL-45ZSXIT

Series:

MoBL®

DiGi-Electronics Programmable:

Not Verified

Memory Format:

SRAM

Memory Size:

4Mbit

Memory Interface:

Parallel

Access Time:

45 ns

Operating Temperature:

-40°C ~ 85°C (TA)

Package / Case:

32-SOIC (0.400", 10.16mm Width)

Base Product Number:

CY62148

Manufacturer:

Infineon Technologies

Product Status:

Active

Memory Type:

Volatile

Technology:

SRAM - Asynchronous

Memory Organization:

512K x 8

Write Cycle Time - Word, Page:

45ns

Voltage - Supply:

4.5V ~ 5.5V

Mounting Type:

Surface Mount

Supplier Device Package:

32-TSOP II

Environmental & Export classification

RoHS Status:

ROHS3 Compliant

REACH Status:

REACH Unaffected

HTSUS:

8542.32.0041

Moisture Sensitivity Level (MSL):

3 (168 Hours)

ECCN:

3A991B2A



Please note that Cypress is an Infineon Technologies Company.

The document following this cover page is marked as “Cypress” document as this is the company that originally developed the product. Please note that Infineon will continue to offer the product to new and existing customers as part of the Infineon product portfolio.

Continuity of document content

The fact that Infineon offers the following product as part of the Infineon product portfolio does not lead to any changes to this document. Future revisions will occur when appropriate, and any changes will be set out on the document history page.

Continuity of ordering part numbers

Infineon continues to support existing part numbers. Please continue to use the ordering part numbers listed in the datasheet for ordering.



CY62148E MoBL

4-Mbit (512K × 8) Static RAM

Features

- Very high speed: 45 ns
- Voltage range: 4.5 V to 5.5 V
- Pin compatible with CY62148B
- Ultra low standby power
 - Typical standby current: 2.5 μ A
 - Maximum standby current: 7 μ A (Industrial)
- Ultra low active power
 - Typical active current: 3.5 mA at f = 1 MHz
- Easy memory expansion with \overline{CE} , and \overline{OE} features
- Automatic power-down when deselected
- Complementary metal oxide semiconductor (CMOS) for optimum speed and power
- Available in Pb-free 32-pin thin small outline package (TSOP) II and 32-pin small-outline integrated circuit (SOIC)^[1] packages

Functional Description

The CY62148E is a high performance CMOS static RAM organized as 512K words by 8-bits. This device features

advanced circuit design to provide ultra low standby current. This is ideal for providing More Battery Life™ (MoBL®) in portable applications. The device also has an automatic power-down feature that significantly reduces power consumption when addresses are not toggling. Placing the device into standby mode reduces power consumption by more than 99% when deselected (\overline{CE} HIGH). The eight input and output pins (I/O₀ through I/O₇) are placed in a high impedance state when the device is deselected (\overline{CE} HIGH), Outputs are disabled (\overline{OE} HIGH), or during an active Write operation (\overline{CE} LOW and \overline{WE} LOW).

To write to the device, take Chip Enable (\overline{CE}) and Write Enable (\overline{WE}) inputs LOW. Data on the eight I/O pins (I/O₀ through I/O₇) is then written into the location specified on the address pins (A₀ through A₁₈).

To read from the device, take Chip Enable (\overline{CE}) and Output Enable (\overline{OE}) LOW while forcing Write Enable (\overline{WE}) HIGH. Under these conditions, the contents of the memory location specified by the address pins appear on the I/O pins.

The CY62148E device is suitable for interfacing with processors that have TTL I/P levels. It is not suitable for processors that require CMOS I/P levels. Please see [Electrical Characteristics on page 4](#) for more details and suggested alternatives.

For a complete list of related documentation, [click here](#).

Logic Block Diagram

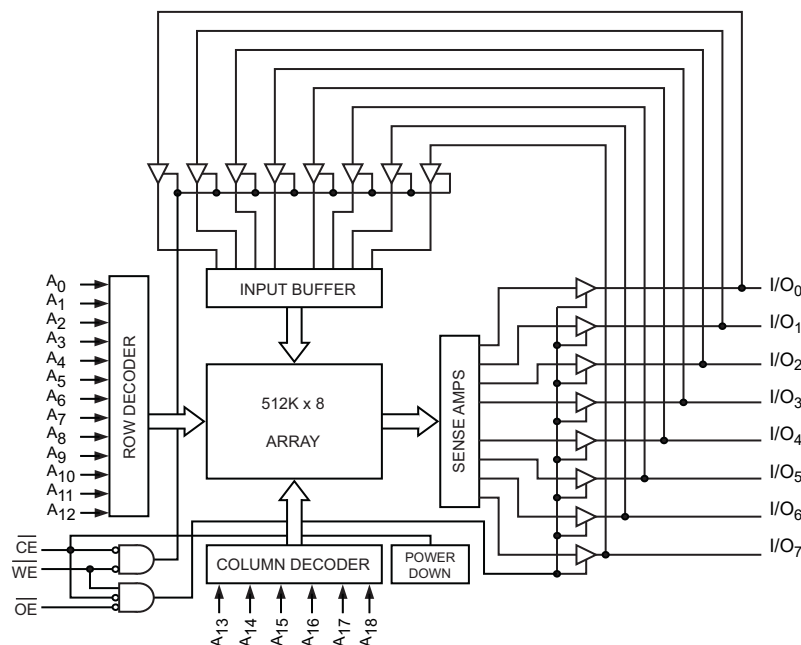

Note

1. SOIC package is available only in 55 ns speed bin.



Contents

Pin Configurations	3	Ordering Information	11
Product Portfolio	3	Ordering Code Definitions	11
Maximum Ratings	4	Package Diagrams	12
Operating Range	4	Acronyms	14
Electrical Characteristics	4	Document Conventions	14
Capacitance	5	Units of Measure	14
Thermal Resistance	5	Document History Page	15
AC Test Loads and Waveforms	5	Sales, Solutions, and Legal Information	19
Data Retention Characteristics	6	Worldwide Sales and Design Support	19
Data Retention Waveform	6	Products	19
Switching Characteristics	7	PSoC® Solutions	19
Switching Waveforms	8	Cypress Developer Community	19
Truth Table	10	Technical Support	19

Pin Configurations

Figure 1. 32-pin SOIC/TSOP II pinout [2]

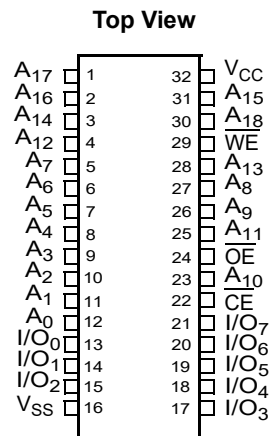

Product Portfolio

Product		Range	V _{CC} Range (V)			Speed (ns)	Power Dissipation						
			Min	Typ ^[3]	Max		Operating I _{CC} (mA)				Standby I _{SB2} (μA)		
f = 1 MHz		f = f _{max}				Typ ^[3]		Max		Typ ^[3]		Max	
CY62148ELL	TSOP II	Industrial	4.5	5.0	5.5	45	3.5	6	15	20	2.5	7	
CY62148ELL	SOIC	Industrial/ Automotive-A	4.5	5.0	5.5	55	3.5	6	15	20	2.5	7	

Notes

- SOIC package is available only in 55 ns speed bin.
- Typical values are included for reference only and are not guaranteed or tested. Typical values are measured at V_{CC} = V_{CC(typ)}, T_A = 25 °C.



Maximum Ratings

Exceeding maximum ratings may shorten the useful life of the device. User guidelines are not tested.

Storage temperature -65 °C to +150 °C

Ambient temperature
with power applied -55 °C to +125 °C

Supply voltage
to ground potential -0.5 V to 6.0 V ($V_{CCmax} + 0.5$ V)

DC voltage applied to outputs
in high Z state ^[4, 5] -0.5 V to 6.0 V ($V_{CCmax} + 0.5$ V)

DC input voltage ^[4, 5] -0.5 V to 6.0 V ($V_{CCmax} + 0.5$ V)

Output current into outputs (LOW) 20 mA

Static discharge voltage
(per MIL-STD-883, Method 3015) > 2001 V

Latch-up current > 200 mA

Operating Range

Device	Range	Ambient Temperature	V_{CC} ^[6]
CY62148E	Industrial/ Automotive-A	-40 °C to +85 °C	4.5 V to 5.5 V

Electrical Characteristics

Over the operating range

Parameter	Description	Test Conditions	45 ns			55 ns ^[7]			Unit	
			Min	Typ ^[8]	Max	Min	Typ ^[8]	Max		
V_{OH} ^[9]	Output HIGH voltage	$V_{CC} = 4.5$ V, $I_{OH} = -1$ mA	2.4	–	–	2.4	–	–	V	
		$V_{CC} = 5.5$ V, $I_{OH} = -0.1$ mA	–	–	3.4 ^[8]	–	–	3.4 ^[8]	V	
V_{OL}	Output LOW voltage	$I_{OL} = 2.1$ mA	–	–	0.4	–	–	0.4	V	
V_{IH}	Input HIGH voltage	$V_{CC} = 4.5$ V to 5.5 V	2.2	–	$V_{CC} + 0.5$	2.2	–	$V_{CC} + 0.5$	V	
V_{IL}	Input LOW voltage	$V_{CC} = 4.5$ V to 5.5 V	For TSOPII package	-0.5	–	0.8	–	–	–	V
			For SOIC package	–	–	–	-0.5	–	0.6 ^[10]	
I_{IX}	Input leakage current	$GND \leq V_I \leq V_{CC}$	-1	–	+1	-1	–	+1	μ A	
I_{OZ}	Output leakage current	$GND \leq V_O \leq V_{CC}$, output disabled	-1	–	+1	-1	–	+1	μ A	
I_{CC}	V_{CC} operating supply current	$f = f_{max} = 1/t_{RC}$	–	15	20	–	15	20	mA	
		$f = 1$ MHz	–	3.5	6	–	3.5	6		
I_{SB2} ^[11]	Automatic \overline{CE} power-down current – CMOS inputs	$\overline{CE} \geq V_{CC} - 0.2$ V, $V_{IN} \geq V_{CC} - 0.2$ V or $V_{IN} \leq 0.2$ V, $f = 0$, $V_{CC} = V_{CC(max)}$	–	2.5	7	–	2.5	7	μ A	

Notes

- $V_{IL(min)}$ = -2.0 V for pulse durations less than 20 ns for $I \leq 30$ mA.
- $V_{IH(max)}$ = $V_{CC} + 0.75$ V for pulse durations less than 20 ns.
- Full device AC operation assumes a minimum of 100 μ s ramp time from 0 to $V_{CC(min)}$ and 200 μ s wait time after V_{CC} stabilization.
- SOIC package is available only in 55 ns speed bin.
- Typical values are included for reference and are not guaranteed or tested. Typical values are measured at $V_{CC} = V_{CC(typ)}$, $T_A = 25$ °C.
- Please note that the maximum V_{OH} limit for this device does not exceed minimum CMOS V_{IH} of 3.5V. If you are interfacing this SRAM with 5 V legacy processors that require a minimum V_{IH} of 3.5 V, please refer to Application Note AN6081 for technical details and options you may consider.
- Under DC conditions the device meets a V_{IL} of 0.8 V. However, in dynamic conditions Input LOW Voltage applied to the device must not be higher than 0.6 V. This is applicable to SOIC package only.
- Chip enable (\overline{CE}) must be HIGH at CMOS level to meet the I_{SB2} / I_{CCDR} spec. Other inputs can be left floating.

Capacitance

Parameter ^[12]	Description	Test Conditions	Max	Unit
C_{IN}	Input capacitance	$T_A = 25\text{ }^\circ\text{C}$, $f = 1\text{ MHz}$, $V_{CC} = V_{CC(Typ)}$	10	pF
C_{OUT}	Output capacitance		10	pF

Thermal Resistance

Parameter ^[12]	Description	Test Conditions	32-pin SOIC Package	32-pin TSOP II Package	Unit
Θ_{JA}	Thermal resistance (junction to ambient)	Still air, soldered on a 3 × 4.5 inch, four-layer printed circuit board	51.57	59.10	$^\circ\text{C/W}$
Θ_{JC}	Thermal resistance (junction to case)		25.01	12.19	$^\circ\text{C/W}$

AC Test Loads and Waveforms

Figure 2. AC Test Loads and Waveforms

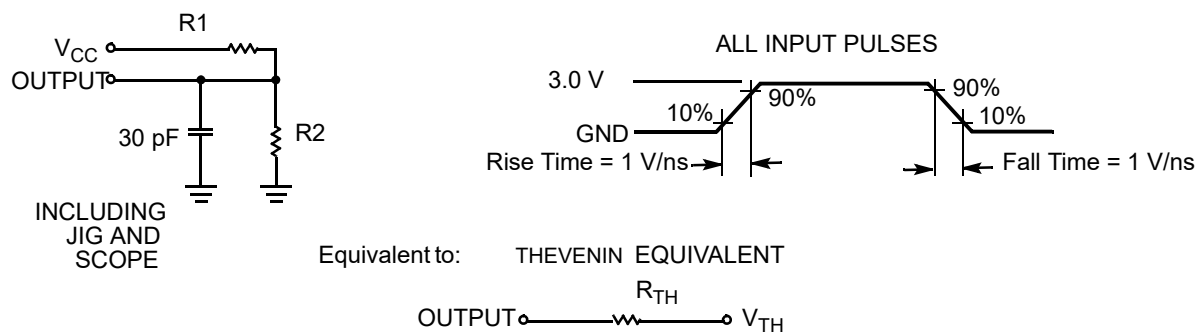

Parameter ^[12]	5.0 V	Unit
R1	1800	Ω
R2	990	Ω
R_{TH}	639	Ω
V_{TH}	1.77	V

Note

12. Tested initially and after any design or process changes that may affect these parameters.

Data Retention Characteristics

Over the operating range

Parameter	Description	Conditions	Min	Typ ^[13]	Max	Unit
V_{DR}	V_{CC} for data retention		2	–	–	V
I_{CCDR} ^[14]	Data retention current	$V_{CC} = V_{DR}$, $\overline{CE} \geq V_{CC} - 0.2\text{ V}$, $V_{IN} \geq V_{CC} - 0.2\text{ V}$ or $V_{IN} \leq 0.2\text{ V}$	–	3	8.8	μA
t_{CDR}	Chip deselect to data retention time		0	–	–	ns
t_R ^[15]	Operation recovery time		45/55	–	–	ns

Data Retention Waveform

Figure 3. Data Retention Waveform

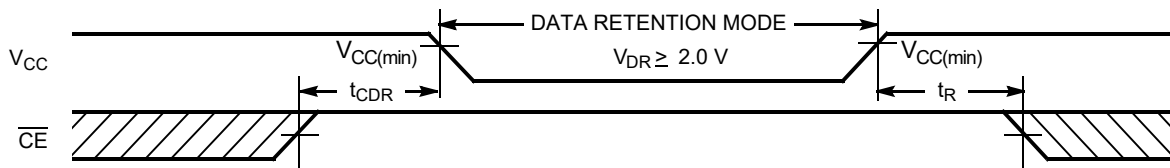

Notes

13. Typical values are included for reference and are not guaranteed or tested. Typical values are measured at $V_{CC} = V_{CC(\text{typ})}$, $T_A = 25\text{ }^\circ\text{C}$.
14. Chip enable (\overline{CE}) must be HIGH at CMOS level to meet the I_{SB2} / I_{CCDR} spec. Other inputs can be left floating.
15. Full device operation requires linear V_{CC} ramp from V_{DR} to $V_{CC(\text{min})} > 100\text{ }\mu\text{s}$ or stable at $V_{CC(\text{min})} > 100\text{ }\mu\text{s}$.



Switching Characteristics

Over the operating range

Parameter ^[16, 17]	Description	45 ns		55 ns ^[18]		Unit
		Min	Max	Min	Max	
Read Cycle						
t_{RC}	Read cycle time	45	–	55	–	ns
t_{AA}	Address to data valid	–	45	–	55	ns
t_{OHA}	Data hold from address change	10	–	10	–	ns
t_{ACE}	\overline{CE} LOW to data valid	–	45	–	55	ns
t_{DOE}	\overline{OE} LOW to data valid	–	22	–	25	ns
t_{LZOE}	\overline{OE} LOW to low Z ^[19]	5	–	5	–	ns
t_{HZOE}	\overline{OE} HIGH to high Z ^[19, 20]	–	18	–	20	ns
t_{LZCE}	\overline{CE} LOW to low Z ^[19]	10	–	10	–	ns
t_{HZCE}	\overline{CE} HIGH to high Z ^[19, 20]	–	18	–	20	ns
t_{PU}	\overline{CE} LOW to power-up	0	–	0	–	ns
t_{PD}	\overline{CE} HIGH to power-down	–	45	–	55	ns
Write Cycle ^[21, 22]						
t_{WC}	Write cycle time	45	–	55	–	ns
t_{SCE}	\overline{CE} LOW to write end	35	–	40	–	ns
t_{AW}	Address setup to write end	35	–	40	–	ns
t_{HA}	Address hold from write end	0	–	0	–	ns
t_{SA}	Address setup to write start	0	–	0	–	ns
t_{PWE}	\overline{WE} pulse width	35	–	40	–	ns
t_{SD}	Data setup to write end	25	–	25	–	ns
t_{HD}	Data hold from write end	0	–	0	–	ns
t_{HZWE}	\overline{WE} LOW to high Z ^[19, 20]	–	18	–	20	ns
t_{LZWE}	\overline{WE} HIGH to low Z ^[19]	10	–	10	–	ns

Notes

16. In an earlier revision of this device, under a specific application condition, READ and WRITE operations were limited to switching of the chip enable signal as described in the Application Note AN66311. However, the issue has been fixed and in production now, and hence, this Application Notes is no longer applicable. It is available for download on our website as it contains information on the date code of the parts, beyond which the fix has been in production.
17. Test conditions for all parameters other than tri-state parameters assume signal transition time of 3 ns or less, timing reference levels of 1.5 V, input pulse levels of 0 to 3 V, and output loading of the specified I_{OL}/I_{OH} as shown in the Figure 2 on page 5.
18. SOIC package is available only in 55 ns speed bin.
19. At any temperature and voltage condition, t_{HZCE} is less than t_{LZCE} , t_{HZOE} is less than t_{LZOE} , and t_{HZWE} is less than t_{LZWE} for any device.
20. t_{HZOE} , t_{HZCE} , and t_{HZWE} transitions are measured when the outputs enter a high impedance state.
21. The internal write time of the memory is defined by the overlap of \overline{WE} , $\overline{CE} = V_{IL}$. All signals must be ACTIVE to initiate a write and any of these signals can terminate a write by going INACTIVE. The data input setup and hold timing should be referenced to the edge of the signal that terminates the write.
22. The minimum write cycle pulse width for Write Cycle No. 3 (\overline{WE} Controlled, \overline{OE} LOW) should be equal to the sum of t_{SD} and t_{HZWE} .

Switching Waveforms

Figure 4. Read Cycle No. 1 (Address Transition Controlled) [23, 24]

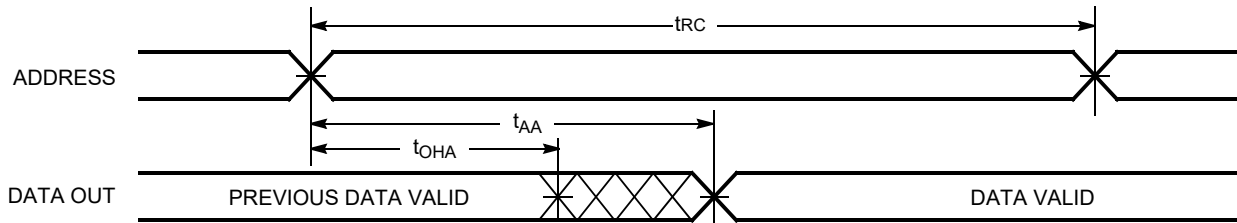

Figure 5. Read Cycle No. 2 ($\overline{\text{OE}}$ Controlled) [24, 25]

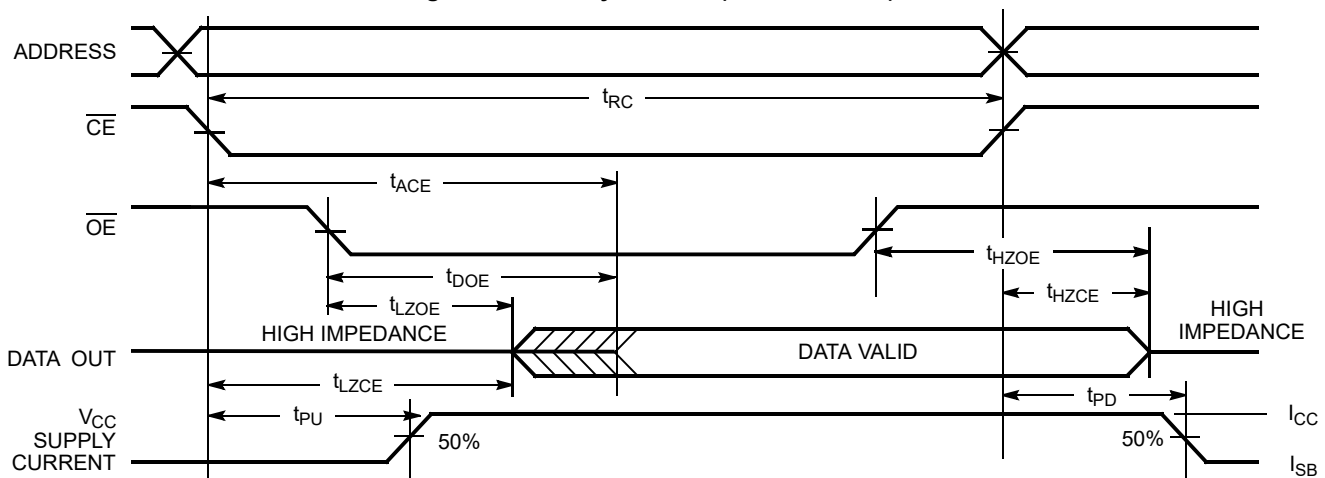
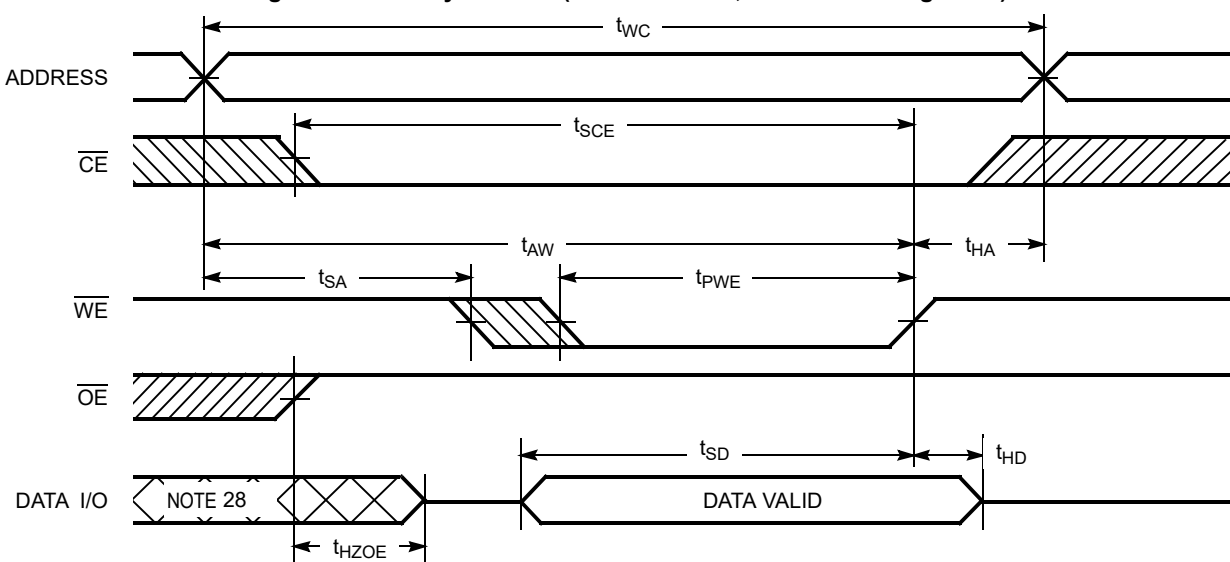

Figure 6. Write Cycle No. 1 ($\overline{\text{WE}}$ Controlled, $\overline{\text{OE}}$ HIGH During Write) [26, 27]



Notes

23. Device is continuously selected. $\overline{\text{OE}}, \overline{\text{CE}} = V_{\text{IL}}$.
24. $\overline{\text{WE}}$ is HIGH for read cycles.
25. Address valid before or similar to $\overline{\text{CE}}$ transition LOW.
26. Data I/O is high impedance if $\overline{\text{OE}} = V_{\text{IH}}$.
27. If $\overline{\text{CE}}$ goes HIGH simultaneously with $\overline{\text{WE}}$ HIGH, the output remains in high impedance state.
28. During this period, the I/Os are in output state and input signals must not be applied.

Switching Waveforms (continued)

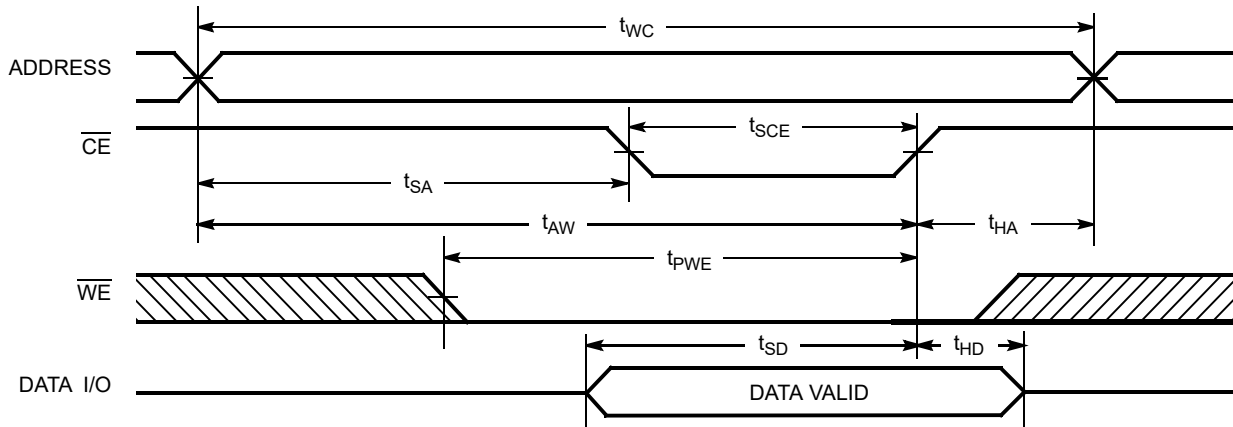
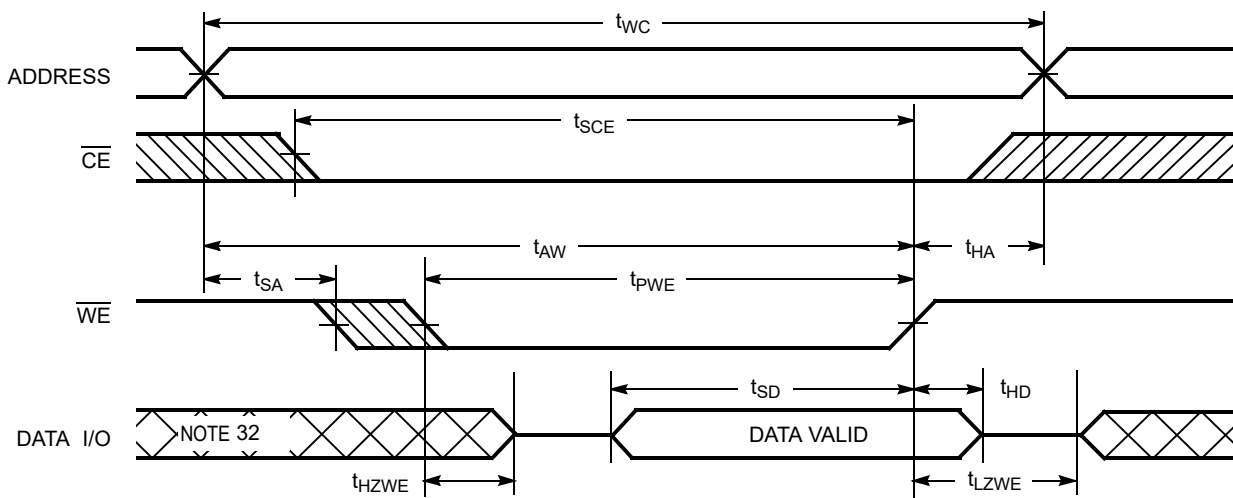
Figure 7. Write Cycle No. 2 ($\overline{\text{CE}}$ Controlled) [29, 30]Figure 8. Write Cycle No. 3 ($\overline{\text{WE}}$ Controlled, $\overline{\text{OE}}$ LOW) [30, 31]**Notes**

29. Data I/O is high impedance if $\overline{\text{OE}} = V_{\text{IH}}$.

30. If $\overline{\text{CE}}$ goes HIGH simultaneously with $\overline{\text{WE}}$ HIGH, the output remains in high impedance state.

31. The minimum write cycle pulse width should be equal to the sum of t_{SD} and t_{HZWE} .

32. During this period, the I/Os are in output state and input signals must not be applied.



Truth Table

\overline{CE}	\overline{WE}	\overline{OE}	I/O	Mode	Power
H ^[33]	X	X	High Z	Deselect/power-down	Standby (I_{SB})
L	H	L	Data out	Read	Active (I_{CC})
L	L	X	Data in	Write	Active (I_{CC})
L	H	H	High Z	Selected, outputs disabled	Active (I_{CC})

Note

33. Chip enable (\overline{CE}) must be HIGH at CMOS level to meet the I_{SB2} / I_{CCDR} spec. Other inputs can be left floating.



Ordering Information

Table 1 lists the CY62148E MoBL key package features and ordering codes. The table contains only the parts that are currently available. If you do not see what you are looking for, contact your local sales representative. For more information, visit the Cypress website at www.cypress.com and refer to the product summary page at <http://www.cypress.com/products>.

Table 1. Key features and Ordering Information

Speed (ns)	Ordering Code	Package Diagram	Package Type	Operating Range
45	CY62148ELL-45ZSXI	51-85095	32-pin TSOP II (Pb-free)	Industrial
55	CY62148ELL-55SXI	51-85081	32-pin SOIC (Pb-free)	Industrial

Contact your local Cypress sales representative for availability of these parts.

Ordering Code Definitions

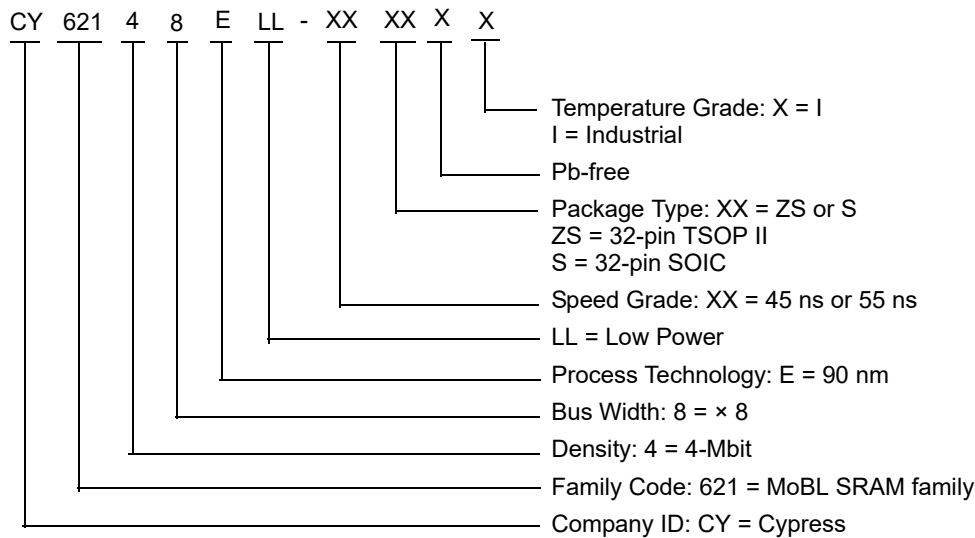

Package Diagrams

Figure 9. 32-pin TSOP II (20.95 × 11.76 × 1.0 mm) Package Outline, 51-85095

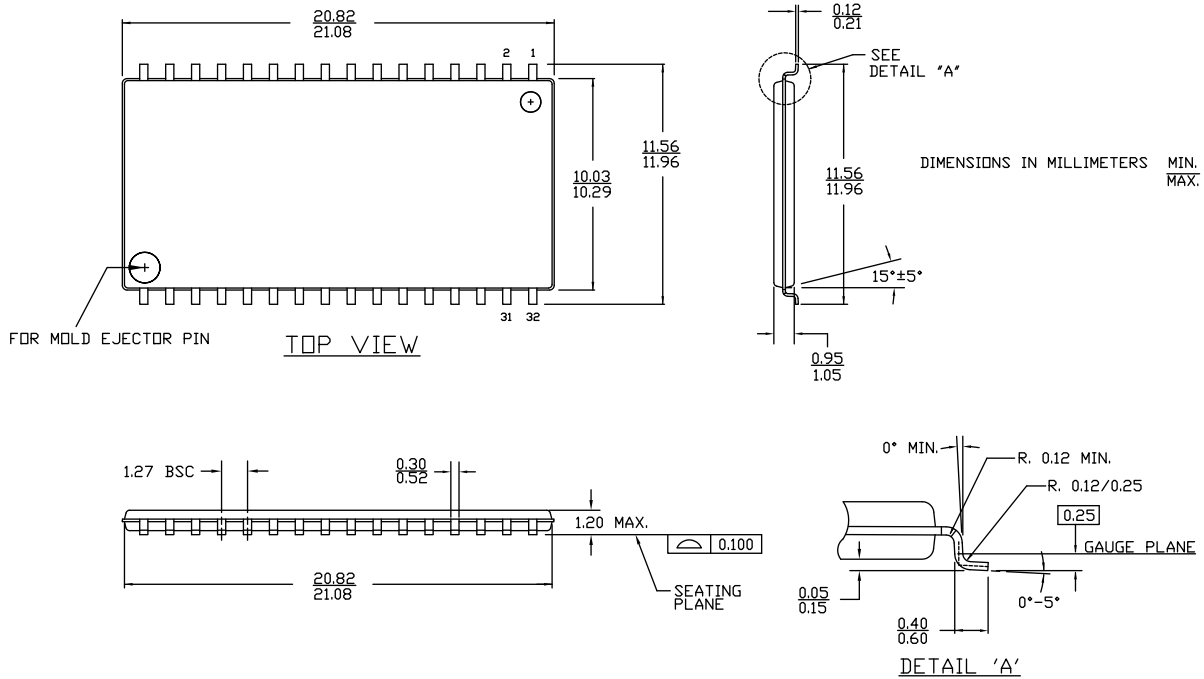

51-85095 *D



Package Diagrams (continued)

Figure 10. 32-pin SOIC (450 Mils) Package Outline, 51-85081

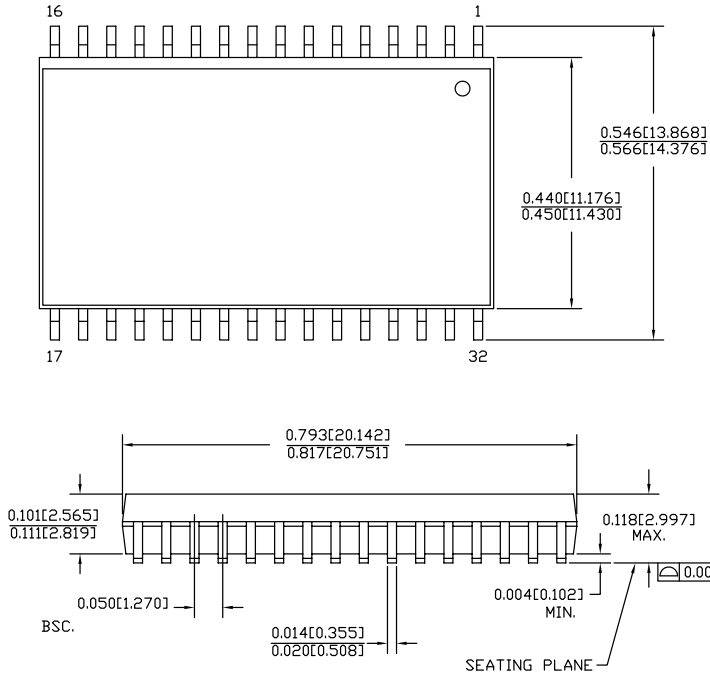

NOTE

1. DIMENSIONS IN INCHES[MM] MIN. MAX.
2. PACKAGE WEIGHT: See Cypress Package Material Declaration Datasheet (PMDD) posted on the Cypress web.
3. The chamfer feature is optional. If it is not present, then Pin 1 identifier must be located within the index area indicated.

PART #	
S32.45	STANDARD PKG.
SZ32.45	LEAD FREE PKG.



51-85081 *F



Acronyms

Acronym	Description
\overline{CE}	Chip Enable
CMOS	Complementary Metal Oxide Semiconductor
I/O	Input/Output
\overline{OE}	Output Enable
MoBL	More Battery Life
SOIC	Small Outline Integrated Circuit
SRAM	Static Random Access Memory
TSOP	Thin Small Outline Package
\overline{WE}	Write Enable

Document Conventions

Units of Measure

Symbol	Unit of Measure
$^{\circ}\text{C}$	degree Celsius
MHz	megahertz
μA	microampere
μs	microsecond
mA	milliampere
ns	nanosecond
Ω	ohm
%	percent
pF	picofarad
V	volt
W	watt



Document History Page

Document Title: CY62148E MoBL, 4-Mbit (512K × 8) Static RAM Document Number: 38-05442			
Revision	ECN	Submission Date	Description of Change
**	201580	01/08/2004	New data sheet.
*A	249276	08/03/2004	<p>Changed status from Advance Information to Preliminary.</p> <p>Updated Features: Added RTSOP II Package related information. Removed FBGA Package related information.</p> <p>Updated Functional Description: Added RTSOP II package related information. Removed FBGA Package related information.</p> <p>Updated Pin Configurations: Added RTSOP II package related information. Removed FBGA Package related information.</p> <p>Updated Operating Range: Updated Note 6 (Changed V_{CC} stabilization time from 100 μs to 200 μs).</p> <p>Updated Data Retention Characteristics: Changed maximum value of I_{CCDR} parameter from 2.0 μA to 2.5 μA. Changed minimum value of t_R parameter from 100 μs to t_{RC} ns.</p> <p>Updated Switching Characteristics: Changed minimum value of t_{OHA} parameter from 6 ns to 10 ns corresponding to both 35 ns and 45 ns speed bins. Changed maximum value of t_{DOE} parameter from 15 ns to 18 ns corresponding to 35 ns speed bin. Changed maximum value of t_{HZOE}, t_{HZWE} parameters from 12 ns to 15 ns corresponding to 35 ns speed bin and 15 ns to 18 ns corresponding to 45 ns speed bin. Changed minimum value of t_{SCE} parameter from 25 ns to 30 ns corresponding to 35 ns speed bin and 40 ns to 35 ns corresponding to 45 ns speed bin. Changed maximum value of t_{HZCE} parameter from 12 ns to 18 ns corresponding to 35 ns speed bin and 15 ns to 22 ns corresponding to 45 ns speed bin. Changed minimum value of t_{SD} parameter from 15 ns to 18 ns corresponding to 35 ns speed bin and 20 ns to 22 ns corresponding to 45 ns speed bin.</p> <p>Updated Ordering Information: Corrected typo in Package Name column. Updated part numbers.</p>
*B	414820	12/16/2005	<p>Changed status from Preliminary to Final.</p> <p>Changed the address of Cypress Semiconductor Corporation on Page 1 from "3901 North First Street" to "198 Champion Court".</p> <p>Updated Features: Removed 35 ns speed bin.</p> <p>Updated Pin Configurations: Removed Note "DNU pins have to be left floating or tied to V_{SS} to ensure proper application." and its reference.</p> <p>Updated Product Portfolio: Removed 35 ns speed bin.</p> <p>Updated Maximum Ratings: Updated Note 4 (to include current limit).</p>



Document History Page (continued)

Document Title: CY62148E MoBL, 4-Mbit (512K × 8) Static RAM Document Number: 38-05442			
Revision	ECN	Submission Date	Description of Change
*B (cont.)	414820	12/16/2005	<p>Updated Electrical Characteristics: Removed “L” version of CY62148E. Changed typical value of I_{CC} parameter from 1.5 mA to 2 mA corresponding to Test Condition “f = 1 MHz”. Changed maximum value of I_{CC} parameter from 2 mA to 2.5 mA corresponding to Test Condition “f = 1 MHz”. changed typical value of I_{CC} parameter from 12 mA to 15 mA corresponding to Test Condition “f = f_{max}”. Removed I_{SB1} parameter and its corresponding details. Changed typical value of I_{SB2} parameter from 0.7 μA to 1 μA. Changed maximum value of I_{SB2} parameter from 2.5 μA to 7 μA. Updated AC Test Loads and Waveforms: Changed the AC test load capacitance from 100 pF to 30 pF in Figure 2. Changed test load parameters R_1, R_2, R_{TH} and V_{TH} from 1838 Ω, 994 Ω, 645 Ω and 1.75 V to 1800 Ω, 990 Ω, 639 Ω and 1.77 V. Updated Data Retention Characteristics: Changed maximum value of I_{CCDR} parameter from 2.5 μA to 7 μA. Added typical value for I_{CCDR} parameter. Updated Switching Characteristics: Removed 35 ns speed bin. Changed minimum value of t_{LZOE} parameter from 3 ns to 5 ns. Changed minimum value of t_{LZCE} and t_{LZWE} parameters from 6 ns to 10 ns. Changed maximum value of t_{HZCE} parameter from 22 ns to 18 ns. Changed minimum value of t_{PWE} parameter from 30 ns to 35 ns. Changed minimum value of t_{SD} parameter from 22 ns to 25 ns. Updated Ordering Information: Updated part numbers. Removed “Package Name” column. Added “Package Diagram” column. Updated to new template.</p>
*C	464503	05/25/2006	<p>Updated Product Portfolio (Included Automotive Range). Updated Operating Range (Included Automotive Range). Updated Electrical Characteristics (Included Automotive Range). Updated Data Retention Characteristics (Included Automotive Range). Updated Switching Characteristics (Included Automotive Range). Updated Ordering Information: Updated part numbers.</p>
*D	485639	07/21/2006	<p>Updated Operating Range: Replaced “2.2 V to 3.6 V” with “4.5 V to 5.5 V” in “V_{CC}” column.</p>
*E	833080	03/09/2007	<p>Updated Electrical Characteristics: Added SOIC package in “Test Conditions” of V_{IL} parameter and also added corresponding values. Added Note 10 and referred the same note in maximum value of V_{IL} parameter corresponding to SOIC package.</p>



Document History Page (continued)

Document Title: CY62148E MoBL, 4-Mbit (512K × 8) Static RAM Document Number: 38-05442			
Revision	ECN	Submission Date	Description of Change
*F	890962	03/09/2007	Updated Pin Configurations : Added Note 2 and referred the same note in Figure 1 . Updated Product Portfolio : Included Automotive-A range and removed Automotive-E range. Updated Operating Range : Included Automotive-A range and removed Automotive-E range. Updated Electrical Characteristics : Included Automotive-A range and removed Automotive-E range. Added Note 11 (related to I_{SB2}) and referred the same note in I_{SB2} parameter. Updated Data Retention Characteristics : Included Automotive-A range and removed Automotive-E range. Updated Switching Characteristics : Included Automotive-A range and removed Automotive-E range. Updated Ordering Information : Updated part numbers.
*G	2947039	06/10/2010	Updated Truth Table : Added Note 33 and referred the same note in " \overline{CE} " column. Updated Ordering Information : Updated part numbers. Updated Package Diagrams : spec 51-85095 – Changed revision from ** to *A. spec 51-85081 – Changed revision from *B to *C. Updated to new template.
*H	3006318	08/23/2010	Updated Data Retention Characteristics : Added Note 14 and referred the same note in I_{CCDR} parameter. Updated Ordering Information : No change in part numbers. Added Ordering Code Definitions . Added Acronyms and Units of Measure . Updated to new template.
*I	3235744	04/20/2011	Updated Functional Description : Removed "For best practice recommendations, refer to the Cypress application note AN1064, SRAM System Guidelines ." at the end. Updated Package Diagrams : spec 51-85095 – Changed revision from *A to *B. Completing Sunset Review.
*J	3302815	07/14/2011	Updated to new template.
*K	3539544	03/01/2012	Updated Electrical Characteristics : Updated Note 10. Updated Package Diagrams : spec 51-85081 – Changed revision from *C to *D. Completing Sunset Review.
*L	3992135	05/06/2013	Updated Functional Description : Updated description. Updated Electrical Characteristics : Added one more Test Condition " $V_{CC} = 5.5\text{ V}$, $I_{OH} = -0.1\text{ mA}$ " for V_{OH} parameter and also added corresponding values. Updated Package Diagrams : spec 51-85081 – Changed revision from *D to *E. Completing Sunset Review.



Document History Page (continued)

Document Title: CY62148E MoBL, 4-Mbit (512K × 8) Static RAM Document Number: 38-05442			
Revision	ECN	Submission Date	Description of Change
*M	4099045	08/19/2013	Updated Switching Characteristics : Added Note 16 and referred the same note in "Parameter" column. Updated to new template.
*N	4576526	11/21/2014	Updated Features : Added "For a complete list of related documentation, click here ." at the end. Updated Switching Characteristics : Added Note 22 and referred the same note in "Write Cycle". Updated Switching Waveforms : Added Note 31 and referred the same note in Figure 8 .
*O	4794169	06/11/2015	Updated Package Diagrams : spec 51-85095 – Changed revision from *B to *D. Updated to new template.
*P	5285890	06/01/2016	Updated Thermal Resistance : Replaced "two-layer" with "four-layer" in "Test Conditions" column. Updated all values in "32-pin SOIC Package" and "32-pin TSOP II Package" columns. Updated Data Retention Characteristics : Removed details in "Conditions" column corresponding to t_R parameter (To match the speed grade). Updated to new template. Completing Sunset Review.
*Q	6072272	02/15/2018	Updated Ordering Information : Updated part numbers. Updated to new template.
*R	6533264	04/04/2019	Updated to new template. Completing Sunset Review.
*S	6906316	06/26/2020	Updated Features : Changed value of Typical standby current from 1 μ A to 2.5 μ A. Changed value of Typical active current from 2 mA to 3.5 mA. Updated Product Portfolio : Changed typical value of Operating I_{CC} from 2 mA to 3.5 mA corresponding to all packages and "f = 1 MHz". Changed maximum value of Operating I_{CC} from 2.5 mA to 6 mA corresponding to all packages and "f = 1 MHz". Changed typical value of Standby, I_{SB2} from 1 μ A to 2.5 μ A corresponding to all packages. Updated Electrical Characteristics : Changed typical value of I_{CC} parameter from 2 mA to 3.5 mA corresponding to all speed bins and Test Condition "f = 1 MHz". Changed maximum value of I_{CC} parameter from 2.5 mA to 6 mA corresponding to all speed bins and Test Condition "f = 1 MHz". Changed typical value of I_{SB1} parameter from 1 μ A to 2.5 μ A corresponding to all speed bins. Changed typical value of I_{SB2} parameter from 1 μ A to 2.5 μ A corresponding to all speed bins. Updated Data Retention Characteristics : Changed typical value of I_{CCDR} parameter from 1 μ A to 3 μ A. Changed maximum value of I_{CCDR} parameter from 7 μ A to 8.8 μ A. Updated Package Diagrams : spec 51-85081 – Changed revision from *E to *F. Updated to new template.



Sales, Solutions, and Legal Information

Worldwide Sales and Design Support

Cypress maintains a worldwide network of offices, solution centers, manufacturer's representatives, and distributors. To find the office closest to you, visit us at [Cypress Locations](#).

Products

Arm® Cortex® Microcontrollers	cypress.com/arm
Automotive	cypress.com/automotive
Clocks & Buffers	cypress.com/clocks
Interface	cypress.com/interface
Internet of Things	cypress.com/iot
Memory	cypress.com/memory
Microcontrollers	cypress.com/mcu
PSoC	cypress.com/psoc
Power Management ICs	cypress.com/pmic
Touch Sensing	cypress.com/touch
USB Controllers	cypress.com/usb
Wireless Connectivity	cypress.com/wireless

PSoC® Solutions

[PSoC 1](#) | [PSoC 3](#) | [PSoC 4](#) | [PSoC 5LP](#) | [PSoC 6 MCU](#)

Cypress Developer Community

[Community](#) | [Code Examples](#) | [Projects](#) | [Video](#) | [Blogs](#) | [Training](#) | [Components](#)

Technical Support

cypress.com/support

© Cypress Semiconductor Corporation, 2004–2020. This document is the property of Cypress Semiconductor Corporation and its subsidiaries ("Cypress"). This document, including any software or firmware included or referenced in this document ("Software"), is owned by Cypress under the intellectual property laws and treaties of the United States and other countries worldwide. Cypress reserves all rights under such laws and treaties and does not, except as specifically stated in this paragraph, grant any license under its patents, copyrights, trademarks, or other intellectual property rights. If the Software is not accompanied by a license agreement and you do not otherwise have a written agreement with Cypress governing the use of the Software, then Cypress hereby grants you a personal, non-exclusive, nontransferable license (without the right to sublicense) (1) under its copyright rights in the Software (a) for Software provided in source code form, to modify and reproduce the Software solely for use with Cypress hardware products, only internally within your organization, and (b) to distribute the Software in binary code form externally to end users (either directly or indirectly through resellers and distributors), solely for use on Cypress hardware product units, and (2) under those claims of Cypress's patents that are infringed by the Software (as provided by Cypress, unmodified) to make, use, distribute, and import the Software solely for use with Cypress hardware products. Any other use, reproduction, modification, translation, or compilation of the Software is prohibited.

TO THE EXTENT PERMITTED BY APPLICABLE LAW, CYPRESS MAKES NO WARRANTY OF ANY KIND, EXPRESS OR IMPLIED, WITH REGARD TO THIS DOCUMENT OR ANY SOFTWARE OR ACCOMPANYING HARDWARE, INCLUDING, BUT NOT LIMITED TO, THE IMPLIED WARRANTIES OF MERCHANTABILITY AND FITNESS FOR A PARTICULAR PURPOSE. No computing device can be absolutely secure. Therefore, despite security measures implemented in Cypress hardware or software products, Cypress shall have no liability arising out of any security breach, such as unauthorized access to or use of a Cypress product. CYPRESS DOES NOT REPRESENT, WARRANT, OR GUARANTEE THAT CYPRESS PRODUCTS, OR SYSTEMS CREATED USING CYPRESS PRODUCTS, WILL BE FREE FROM CORRUPTION, ATTACK, VIRUSES, INTERFERENCE, HACKING, DATA LOSS OR THEFT, OR OTHER SECURITY INTRUSION (collectively, "Security Breach"). Cypress disclaims any liability relating to any Security Breach, and you shall and hereby do release Cypress from any claim, damage, or other liability arising from any Security Breach. In addition, the products described in these materials may contain design defects or errors known as errata which may cause the product to deviate from published specifications. To the extent permitted by applicable law, Cypress reserves the right to make changes to this document without further notice. Cypress does not assume any liability arising out of the application or use of any product or circuit described in this document. Any information provided in this document, including any sample design information or programming code, is provided only for reference purposes. It is the responsibility of the user of this document to properly design, program, and test the functionality and safety of any application made of this information and any resulting product. "High-Risk Device" means any device or system whose failure could cause personal injury, death, or property damage. Examples of High-Risk Devices are weapons, nuclear installations, surgical implants, and other medical devices. "Critical Component" means any component of a High-Risk Device whose failure to perform can be reasonably expected to cause, directly or indirectly, the failure of the High-Risk Device, or to affect its safety or effectiveness. Cypress is not liable, in whole or in part, and you shall and hereby do release Cypress from any claim, damage, or other liability arising from any use of a Cypress product as a Critical Component in a High-Risk Device. You shall indemnify and hold Cypress, its directors, officers, employees, agents, affiliates, distributors, and assigns harmless from and against all claims, costs, damages, and expenses, arising out of any claim, including claims for product liability, personal injury or death, or property damage arising from any use of a Cypress product as a Critical Component in a High-Risk Device. Cypress products are not intended or authorized for use as a Critical Component in any High-Risk Device except to the limited extent that (i) Cypress's published data sheet for the product explicitly states Cypress has qualified the product for use in a specific High-Risk Device, or (ii) Cypress has given you advance written authorization to use the product as a Critical Component in the specific High-Risk Device and you have signed a separate indemnification agreement.

Cypress, the Cypress logo, Spansion, the Spansion logo, and combinations thereof, WICED, PSoC, CapSense, EZ-USB, F-RAM, and Traveo are trademarks or registered trademarks of Cypress in the United States and other countries. For a more complete list of Cypress trademarks, visit cypress.com. Other names and brands may be claimed as property of their respective owners.

OUR CERTIFICATE

DiGi provide top-quality products and perfect service for customer worldwide through standardization, technological innovation and continuous improvement. DiGi through third-party certification, we stricly control the quality of products and services. Welcome your RFQ to

Email: Info@DiGi-Electronics.com



Tel: +00 852-30501935

RFQ Email: Info@DiGi-Electronics.com

DiGi is a global authorized distributor of electronic components.