

CY62162G18-55BGXIT Datasheet

www.digi-electronics.com

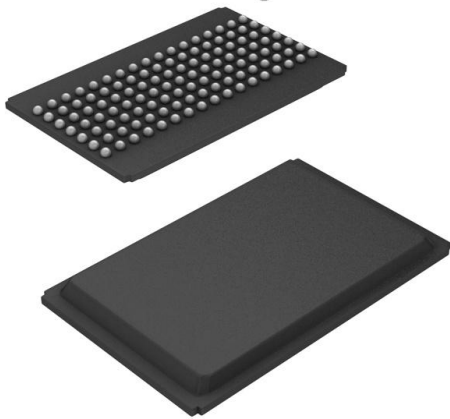

<https://www.DiGi-Electronics.com>

DiGi Electronics Part Number	CY62162G18-55BGXIT-DG
Manufacturer	Infineon Technologies
Manufacturer Product Number	CY62162G18-55BGXIT
Description	IC SRAM 16MBIT PARALLEL 119PBGA
Detailed Description	SRAM - Asynchronous Memory IC 16Mbit Parallel 55 ns 119-PBGA (14x22)

This model CY62162G18-55BGXIT is available at DiGi Electronics.

DiGi Electronics offers a global database of semiconductor and electronic component datasheets.

We welcome your inquiries regarding pricing, lead time, or other product-related questions.

 [Request a Quote](#)

 [Datasheet Search](#)



Tel: +00 852-30501935

RFQ Email: Info@DiGi-Electronics.com

DiGi is a global authorized distributor of electronic components.

Purchase and inquiry

Manufacturer Product Number:

CY62162G18-55BGXIT

Series:

MoBL®

DiGi-Electronics Programmable:

Not Verified

Memory Format:

SRAM

Memory Size:

16Mbit

Memory Interface:

Parallel

Access Time:

55 ns

Operating Temperature:

-40°C ~ 85°C (TA)

Package / Case:

119-BGA

Base Product Number:

CY62162

Manufacturer:

Infineon Technologies

Product Status:

Active

Memory Type:

Volatile

Technology:

SRAM - Asynchronous

Memory Organization:

512K x 32

Write Cycle Time - Word, Page:

55ns

Voltage - Supply:

1.65V ~ 2.2V

Mounting Type:

Surface Mount

Supplier Device Package:

119-PBGA (14x22)

Environmental & Export classification

RoHS Status:

ROHS3 Compliant

REACH Status:

REACH Unaffected

HTSUS:

8542.32.0041

Moisture Sensitivity Level (MSL):

3 (168 Hours)

ECCN:

3A991B2A



Please note that Cypress is an Infineon Technologies Company.

The document following this cover page is marked as “Cypress” document as this is the company that originally developed the product. Please note that Infineon will continue to offer the product to new and existing customers as part of the Infineon product portfolio.

Continuity of document content

The fact that Infineon offers the following product as part of the Infineon product portfolio does not lead to any changes to this document. Future revisions will occur when appropriate, and any changes will be set out on the document history page.

Continuity of ordering part numbers

Infineon continues to support existing part numbers. Please continue to use the ordering part numbers listed in the datasheet for ordering.



CY62162G/CY62162GE MoBL

16-Mbit (512K × 32) Static RAM
with Error-Correcting Code (ECC)

Features

- Ultra-low standby power
 - Typical standby current: 5.5 μ A
 - Maximum standby current: 16 μ A
- High speed: 45 ns/55 ns
- Embedded error-correcting code (ECC) for single-bit error correction
- Wide voltage range: 1.65 V to 2.2 V, 2.2 V to 3.6 V
- 1.0-V data retention
- Transistor-transistor logic (TTL) compatible inputs and outputs
- ERR pin to indicate 1-bit error detection and correction
- Easy memory expansion with \overline{CE}_1 and CE_2 features
- Available in Pb-free 119-ball PBGA package, 512K × 32 bits SRAM

Functional Description

The CY62162G and CY62162GE devices are high performance CMOS MoBL SRAM organized as 512K words by 32-bits. Both CY62162G and CY62162GE are available with dual chip enables. CY62162GE includes an error indication pin that signals the host processor in the case of a single bit error-detection and correction event. It is ideal for providing More Battery Life™ (MoBL®) in portable applications such as cellular telephones. The device also has an automatic power down

feature that reduces power consumption when addresses are not toggling. Placing the device into standby mode reduces power consumption by more than 99% when deselected (\overline{CE}_1 HIGH or CE_2 LOW or \overline{B}_{A-D} HIGH). The input and output pins (I/O_0 through I/O_{31}) are placed in a high impedance state when deselected (\overline{CE}_1 HIGH or CE_2 LOW) or outputs are disabled (\overline{OE} HIGH) or the byte selects are disabled (\overline{B}_{A-D} HIGH).

To write to the device, take chip enables (\overline{CE}_1 LOW, CE_2 HIGH) and write enable (\overline{WE}) input LOW. If byte enable A (\overline{B}_A) is LOW, then data from I/O pins (I/O_0 through I/O_7) is written into the location specified on the address pins (A_0 through A_{18}). If byte enable B (\overline{B}_B) is LOW, then data from I/O pins (I/O_8 through I/O_{15}) is written into the location specified on the address pins (A_0 through A_{18}). Likewise, \overline{B}_C and \overline{B}_D correspond with the I/O pins I/O_{16} to I/O_{23} and I/O_{24} to I/O_{31} , respectively.

To read from the device, take chip enables (\overline{CE}_1 LOW, CE_2 HIGH), and output enable (\overline{OE}) LOW while forcing the write enable (\overline{WE}) HIGH. If the first byte enable (\overline{B}_A) is LOW, then data from the memory location specified by the address pins appear on I/O_0 to I/O_7 . If byte enable (\overline{B}_B) is LOW, then data from memory appears on I/O_8 to I/O_{15} . Likewise, \overline{B}_C and \overline{B}_D correspond to the third and fourth bytes. During Read operation, in case of a single bit error detection and correction, ERR is asserted HIGH^[1]. See the [Truth Table – CY62162G/CY62162GE](#) on page 14 for a complete description of read and write modes.

CY62162G and CY62162GE devices are available in a 119-ball PBGA package with center power and ground pinout.

Product Portfolio

Product	Features and Options (see the Pin Configurations Section)	Range	V_{CC} Range (V)	Speed (ns)	Power Dissipation			
					Operating I_{CC} , (mA)		Standby, I_{SB2} (μ A)	
					$f = f_{max}$			
					Typ ^[2]	Max	Typ ^[2]	Max
CY62162G(E)18	Dual Chip Enable Optional Error indication on ERR pinout	Industrial	1.65 V–2.2 V	55	29	32	7	26
CY62162G(E)30			2.2 V–3.6 V	45	29	36	5.5	16

Notes

1. This device does not support automatic write-back on error detection.
2. Typical values are included for reference only and are not guaranteed or tested. Typical values are measured at $V_{CC} = 1.8$ V (for V_{CC} range of 1.65 V–2.2 V), $V_{CC} = 3$ V (for V_{CC} range of 2.2 V–3.6 V), $T_A = 25$ °C.



Logic Block Diagram – CY62162G

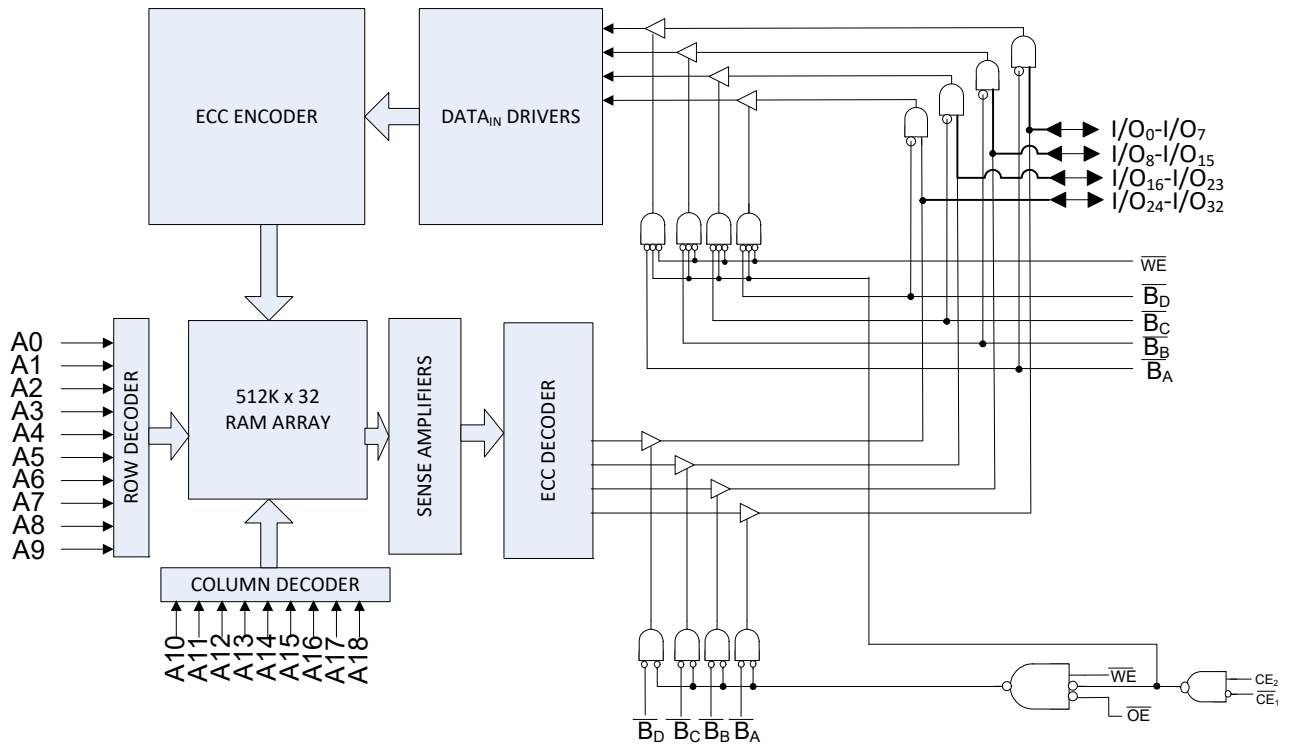

Logic Block Diagram – CY62162GE

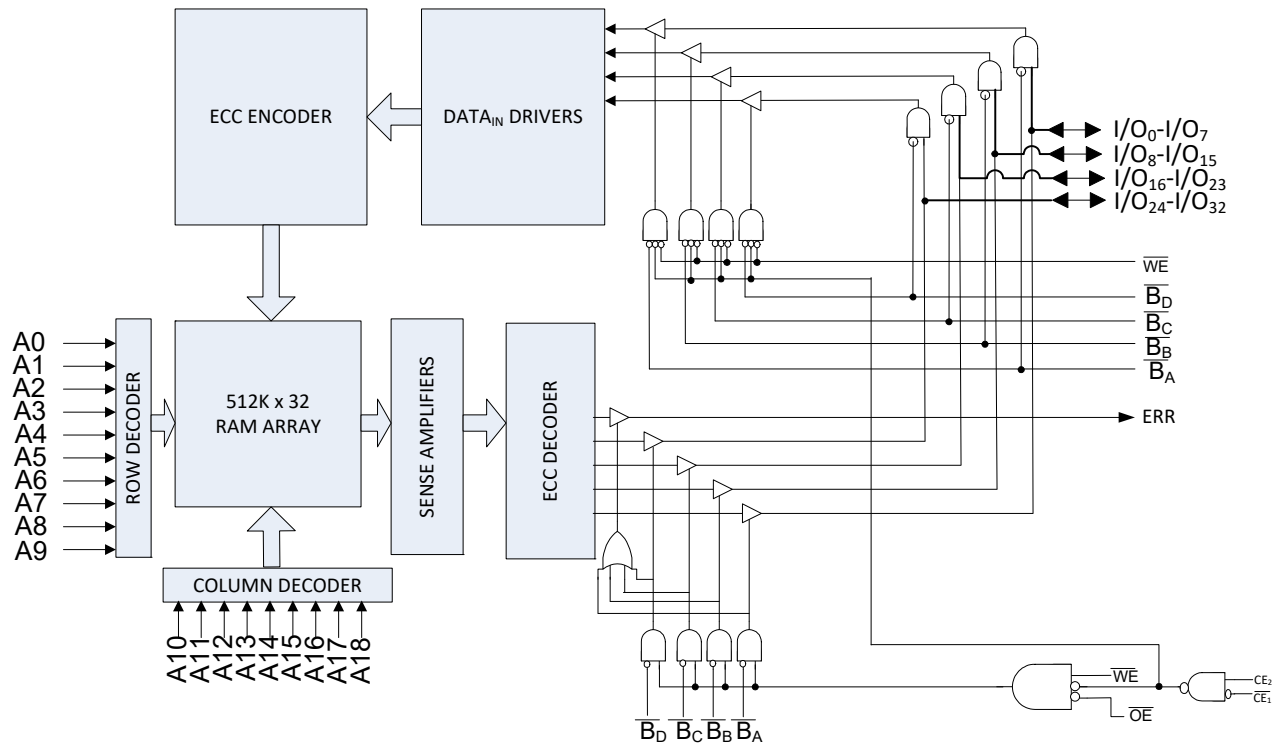



Contents

Pin Configurations	5	Ordering Information	15
Maximum Ratings	6	Ordering Code Definitions	15
Operating Range	6	Package Diagram	16
Electrical Characteristics	6	Acronyms	17
Capacitance	7	Document Conventions	17
Thermal Resistance	7	Units of Measure	17
AC Test Loads and Waveforms	7	Document History Page	18
Data Retention Characteristics	8	Sales, Solutions, and Legal Information	20
Data Retention Waveform	8	Worldwide Sales and Design Support	20
Switching Characteristics	9	Products	20
Switching Waveforms	10	PSoC® Solutions	20
Truth Table – CY62162G/CY62162GE	14	Cypress Developer Community	20
ERR Output – CY62162GE	14	Technical Support	20



Pin Configurations

Figure 1. 119-ball FBGA pinout ^[3]
CY62162G (512K × 32)

	1	2	3	4	5	6	7
A	I/O ₁₆	A ₄	A ₃	A ₂	A ₁	A ₀	I/O ₀
B	I/O ₁₇	A ₁₈	A ₁₇	\overline{CE}_1	A ₁₆	A ₁₅	I/O ₁
C	I/O ₁₈	\overline{B}_c	CE ₂	NC	NC	\overline{B}_a	I/O ₂
D	I/O ₁₉	V _{CC}	GND	GND	GND	V _{CC}	I/O ₃
E	I/O ₂₀	GND	V _{CC}	GND	V _{CC}	GND	I/O ₄
F	I/O ₂₁	V _{CC}	GND	GND	GND	V _{CC}	I/O ₅
G	I/O ₂₂	GND	V _{CC}	GND	V _{CC}	GND	I/O ₆
H	I/O ₂₃	V _{CC}	GND	GND	GND	V _{CC}	I/O ₇
J	NC	GND	V _{CC}	GND	V _{CC}	GND	NC
K	I/O ₂₄	V _{CC}	GND	GND	GND	V _{CC}	I/O ₈
L	I/O ₂₅	GND	V _{CC}	GND	V _{CC}	GND	I/O ₉
M	I/O ₂₆	V _{CC}	GND	GND	GND	V _{CC}	I/O ₁₀
N	I/O ₂₇	GND	V _{CC}	GND	V _{CC}	GND	I/O ₁₁
P	I/O ₂₈	V _{CC}	GND	GND	GND	V _{CC}	I/O ₁₂
R	I/O ₂₉	A ₁₄	B _d	NC	B _b	A ₁₃	I/O ₁₃
T	I/O ₃₀	A ₁₂	A ₁₁	\overline{WE}	A ₁₀	A ₉	I/O ₁₄
U	I/O ₃₁	A ₈	A ₇	\overline{OE}	A ₆	A ₅	I/O ₁₅

Figure 2. 119-ball FBGA pinout ^[3, 4]
CY62162GE (512K × 32)

	1	2	3	4	5	6	7
A	I/O ₁₆	A ₄	A ₃	A ₂	A ₁	A ₀	I/O ₀
B	I/O ₁₇	A ₁₈	A ₁₇	\overline{CE}_1	A ₁₆	A ₁₅	I/O ₁
C	I/O ₁₈	\overline{B}_c	CE ₂	NC	NC	\overline{B}_a	I/O ₂
D	I/O ₁₉	V _{CC}	GND	GND	GND	V _{CC}	I/O ₃
E	I/O ₂₀	GND	V _{CC}	GND	V _{CC}	GND	I/O ₄
F	I/O ₂₁	V _{CC}	GND	GND	GND	V _{CC}	I/O ₅
G	I/O ₂₂	GND	V _{CC}	GND	V _{CC}	GND	I/O ₆
H	I/O ₂₃	V _{CC}	GND	GND	GND	V _{CC}	I/O ₇
J	ERR	GND	V _{CC}	GND	V _{CC}	GND	NC
K	I/O ₂₄	V _{CC}	GND	GND	GND	V _{CC}	I/O ₈
L	I/O ₂₅	GND	V _{CC}	GND	V _{CC}	GND	I/O ₉
M	I/O ₂₆	V _{CC}	GND	GND	GND	V _{CC}	I/O ₁₀
N	I/O ₂₇	GND	V _{CC}	GND	V _{CC}	GND	I/O ₁₁
P	I/O ₂₈	V _{CC}	GND	GND	GND	V _{CC}	I/O ₁₂
R	I/O ₂₉	A ₁₄	\overline{B}_d	NC	\overline{B}_b	A ₁₃	I/O ₁₃
T	I/O ₃₀	A ₁₂	A ₁₁	\overline{WE}	A ₁₀	A ₉	I/O ₁₄
U	I/O ₃₁	A ₈	A ₇	\overline{OE}	A ₆	A ₅	I/O ₁₅

Notes

3. NC pins are not connected internally to the die.
4. ERR is an Output pin. If not used, this pin should be left floating.



CY62162G/CY62162GE MoBL

Maximum Ratings

Exceeding maximum ratings may impair the useful life of the device. These user guidelines are not tested.

Storage temperature -65 °C to +150 °C

Ambient temperature
with power applied -55 °C to +125 °C

Supply voltage to ground potential -0.5 V to $V_{CC} + 0.5$ V

DC voltage applied to outputs
in high Z State^[6] -0.5 V to $V_{CC} + 0.5$ V

DC input voltage^[6] -0.5 V to $V_{CC} + 0.5$ V

Output current into outputs (LOW) 20 mA

Static discharge voltage
(per MIL-STD-883, method 3015) > 2001 V

Latch-up current > 140 mA

Operating Range

Device	Range	Ambient Temperature	V_{CC} ^[7]
CY62162G	Industrial	-40 °C to +85 °C	1.65 V to 2.2 V, 2.2 V to 3.6 V

Electrical Characteristics

Over the Operating Range

Parameter	Description	Test Conditions	Min	Typ ^[8]	Max	Unit	
V_{OH}	Output HIGH voltage	1.65 V to 2.2 V	$V_{CC} = \text{Min}$, $I_{OH} = -0.1$ mA	1.4	–	–	V
		2.2 V to 2.7 V	$V_{CC} = \text{Min}$, $I_{OH} = -1.0$ mA	2.0	–	–	
		2.7 V to 3.6 V	$V_{CC} = \text{Min}$, $I_{OH} = -4.0$ mA	2.2	–	–	
V_{OL}	Output LOW voltage	1.65 V to 2.2 V	$V_{CC} = \text{Min}$, $I_{OL} = 0.1$ mA	–	–	0.2	
		2.2 V to 2.7 V	$V_{CC} = \text{Min}$, $I_{OL} = 2$ mA	–	–	0.4	
		2.7 V to 3.6 V	$V_{CC} = \text{Min}$, $I_{OL} = 8$ mA	–	–	0.4	
V_{IH}	Input HIGH voltage	1.65 V to 2.2 V	–	1.4	–	$V_{CC} + 0.2$	
		2.2 V to 2.7 V	–	2.0	–	$V_{CC} + 0.3$	
		2.7 V to 3.6 V	–	2.0	–	$V_{CC} + 0.3$	
V_{IL}	Input LOW voltage ^[6]	1.65 V to 2.2 V	–	-0.2	–	0.4	
		2.2 V to 2.7 V	–	-0.3	–	0.6	
		2.7 V to 3.6 V	–	-0.3	–	0.8	
I_{IX}	Input leakage current	$GND \leq V_{IN} \leq V_{CC}$	-1.0	–	+1.0	μ A	
I_{OZ}	Output leakage current	$GND \leq V_{OUT} \leq V_{CC}$, Output disabled	-1.0	–	+1.0		
I_{CC}	V_{CC} operating supply current	$f = 22.22$ MHz (45 ns)	$V_{CC} = V_{CC(\text{max})}$, $I_{OUT} = 0$ mA CMOS levels	–	29.0	36.0	mA
		$f = 18.18$ MHz (55 ns)		–	29.0	32.0	
		$f = 1$ MHz		–	7.0	9.0	
I_{SB1} ^[9]	Automatic power down current – CMOS inputs; $V_{CC} = 2.2$ to 3.6 V	$\overline{CE}_1 \geq V_{CC} - 0.2$ V or $CE_2 \leq 0.2$ V	–	5.5	16.0	μ A	
	Automatic power down current – CMOS inputs; $V_{CC} = 1.65$ to 2.2 V	or $\overline{B}_{A-D} \geq V_{CC} - 0.2$ V, $V_{IN} \geq V_{CC} - 0.2$ V, $V_{IN} \leq 0.2$ V, $f = f_{\text{max}}$ (address and data only), $f = 0$ (OE, and WE), $V_{CC} = V_{CC(\text{max})}$	–	7.0	26.0		
I_{SB2} ^[9]	Automatic power down current – CMOS inputs; $V_{CC} = 2.2$ to 3.6 V	$\overline{CE}_1 \geq V_{CC} - 0.2$ V or $CE_2 \leq 0.2$ V	–	5.5	16.0		
	Automatic power down current – CMOS inputs; $V_{CC} = 1.65$ to 2.2 V	or $\overline{B}_{A-D} \geq V_{CC} - 0.2$ V, $V_{IN} \geq V_{CC} - 0.2$ V or $V_{IN} \leq 0.2$ V, $f = 0$, $V_{CC} = V_{CC(\text{max})}$	–	7.0	26.0		

Notes

- Typical values are included for reference only and are not guaranteed or tested. Typical values are measured at $V_{CC} = 1.8$ V (for V_{CC} range of 1.65 V–2.2 V), $V_{CC} = 3$ V (for V_{CC} range of 2.2 V–3.6 V), $T_A = 25$ °C.
- $V_{IL(\text{min})} = -2.0$ V and $V_{IH(\text{max})} = V_{CC} + 2$ V for pulse durations of less than 2 ns.
- Full device AC operation assumes a 100- μ s ramp time from 0 to V_{CC} (min) and 200- μ s wait time after V_{CC} stabilizes to its operational value.
- Indicates the value for the center of distribution at 3.0 V, 25 °C and not 100% tested.
- Chip enables (CE_1 and CE_2) must be tied to CMOS levels to meet the $I_{SB1}/I_{SB2}/I_{CCDR}$ spec. Other inputs can be left floating.



Capacitance

Parameter ^[10]	Description	Test Conditions	Max	Unit
C _{IN}	Input capacitance	T _A = 25 °C, f = 1 MHz, V _{CC} = V _{CC(typ)}	10	pF
C _{OUT}	Output capacitance			

Thermal Resistance

Parameter ^[10]	Description	Test Conditions	119-ball BGA	Unit
θ _{JA}	Thermal resistance (junction to ambient)	Still air, soldered on a 3 × 4.5 inch, 2-layer printed circuit board	20.92	°C/W
θ _{JC}	Thermal resistance (junction to case)		15.84	

AC Test Loads and Waveforms

Figure 3. AC Test Loads and Waveforms

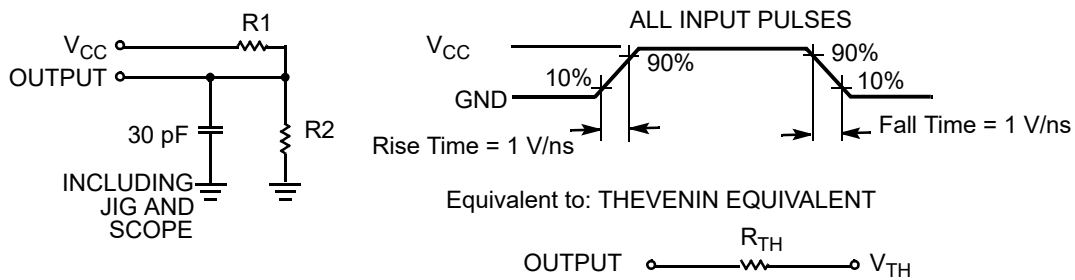

Table 1. AC Test Loads

Parameter	1.8 V	2.5 V	3.0 V	Unit
R1	13500	16667	1103	Ω
R2	10800	15385	1554	
R _{TH}	6000	8000	645	
V _{TH}	0.8	1.2	1.75	V

Note

10. Tested initially and after any design or process changes that may affect these parameters.



Data Retention Characteristics

Over the Operating Range

Parameter	Description	Conditions	Min	Typ ^[11]	Max	Unit
V_{DR}	V_{CC} for data retention		1.0	–	–	V
I_{CCDR} ^[12, 13]	Data retention current	$1.0\text{ V} \leq V_{CC} \leq 2.2\text{ V}$, $\overline{CE}_1 \geq V_{CC} - 0.2\text{ V}$ or $CE_2 \leq 0.2\text{ V}$ or $\overline{B}_{A-D} \geq V_{CC} - 0.2\text{ V}$, $V_{IN} \geq V_{CC} - 0.2\text{ V}$ or $V_{IN} \leq 0.2\text{ V}$	–	7.0	26.0	μA
		$2.2\text{ V} < V_{CC} \leq 3.6\text{ V}$, $\overline{CE}_1 \geq V_{CC} - 0.2\text{ V}$ or $CE_2 \leq 0.2\text{ V}$ or $\overline{B}_{A-D} \geq V_{CC} - 0.2\text{ V}$, $V_{IN} \geq V_{CC} - 0.2\text{ V}$ or $V_{IN} \leq 0.2\text{ V}$	–	5.5	16.0	
t_{CDR} ^[14]	Chip deselect to data retention time	–	0	–	–	ns
t_R ^[14, 15]	Operation recovery time	–	45 / 55	–	–	

Data Retention Waveform

Figure 4. Data Retention Waveform

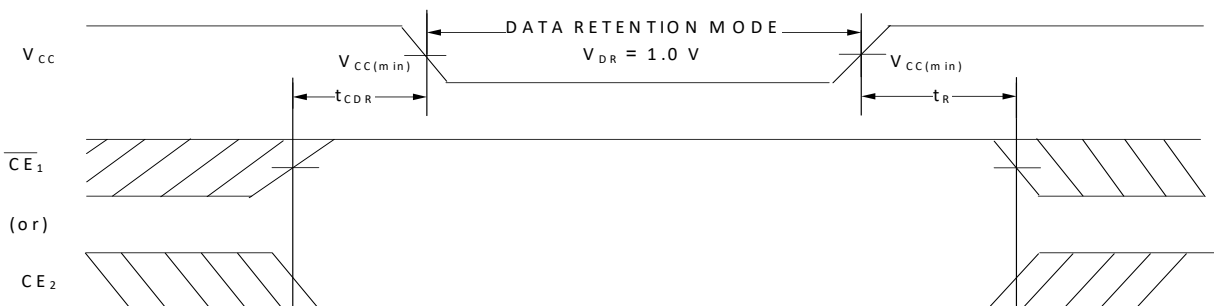

Notes

- Typical values are included for reference only and are not guaranteed or tested. Typical values are measured at $V_{CC} = 1.8\text{ V}$ for the range 1.7 V to 2.2 V; 3 V for the range 2.2 V to 3.6 V, $T_A = 25\text{ }^\circ\text{C}$.
- Only chip enables (\overline{CE}_1 and CE_2) and all byte enables (\overline{B}_{A-D}) need to be tied to CMOS levels to meet the I_{SB2}/I_{CCDR} spec. Other inputs can be left floating.
- \overline{B}_{A-D} is the AND of \overline{B}_A , \overline{B}_B , \overline{B}_C and \overline{B}_D . Chip is deselected by either disabling the chip enable signals or by disabling all byte enables together.
- These parameters are guaranteed by design and are not tested.
- Full device operation requires linear V_{CC} ramp from V_{DR} to $V_{CC(min)} \geq 100\text{ }\mu\text{s}$ or stable at $V_{CC(min)} \geq 100\text{ }\mu\text{s}$.



Switching Characteristics

Over the Operating Range

Parameter ^[16, 17]	Description	45 ns		55 ns		Unit
		Min	Max	Min	Max	
Read Cycle						
t_{RC}	Read cycle time	45.0	–	55.0	–	ns
t_{AA}	Address to data/ERR valid	–	45.0	–	55.0	
t_{OHA}	Data/ERR hold from address change	10	–	10.0	–	
t_{ACE}	\overline{CE}_1 LOW and CE_2 HIGH to data/ERR valid	–	45.0	–	55.0	
t_{DOE}	\overline{OE} LOW to data/ERR valid	–	22.0	–	25.0	
t_{LZOE}	\overline{OE} LOW to low Z ^[17, 18]	5.0	–	5.0	–	
t_{HZOE}	\overline{OE} HIGH to high Z ^[17, 18, 19]	–	18.0	–	18.0	
t_{LZCE}	\overline{CE}_1 LOW and CE_2 HIGH to low Z ^[17, 18]	10.0	–	10.0	–	
t_{HZCE}	\overline{CE}_1 HIGH and CE_2 LOW to high Z ^[17, 18, 19]	–	18.0	–	18.0	
t_{PU}	\overline{CE}_1 LOW and CE_2 HIGH to power-up ^[20]	0	–	0	–	
t_{PD}	\overline{CE}_1 HIGH and CE_2 LOW to power-down ^[20]	–	45.0	–	55.0	
t_{DBE}	Byte enable LOW to data valid	–	45.0	–	55.0	
t_{LZBE}	Byte enable LOW to low Z ^[17]	5.0	–	5.0	–	
t_{HZBE}	Byte enable HIGH to high Z ^[17, 19]	–	18.0	–	18.0	
Write Cycle ^[21, 22]						
t_{WC}	Write cycle time	45.0	–	55.0	–	ns
t_{SCE}	\overline{CE}_1 LOW and CE_2 HIGH to write end	35.0	–	40.0	–	
t_{AW}	Address setup to write end	35.0	–	40.0	–	
t_{HA}	Address hold from write end	0	–	0	–	
t_{SA}	Address setup to write start	0	–	0	–	
t_{PWE}	\overline{WE} pulse width	35.0	–	40.0	–	
t_{BW}	Byte enable LOW to write end	35.0	–	40.0	–	
t_{SD}	Data setup to write end	25.0	–	25.0	–	
t_{HD}	Data hold from write end	0	–	0	–	
t_{HZWE}	\overline{WE} LOW to high Z ^[17, 18, 19]	–	18.0	–	20.0	
t_{LZWE}	\overline{WE} HIGH to low Z ^[17, 18]	10.0	–	10.0	–	

Notes

- Test conditions for all parameters other than tri-state parameters assume signal transition time of 1 V/ns, timing reference levels of V_{TH} , input pulse levels of 0 to $V_{CC(typ)}$, and output loading of the specified I_{OL}/I_{OH} as shown in Table 1 on page 7.
- At any temperature and voltage condition, t_{HZCE} is less than t_{LZCE} , t_{HZBE} is less than t_{LZBE} , t_{HZOE} is less than t_{LZOE} , and t_{HZWE} is less than t_{LZWE} for any given device.
- Tested initially and after any design or process changes that may affect these parameters.
- t_{HZOE} , t_{HZCE} , t_{HZBE} , and t_{HZWE} transitions are measured when the outputs enter a high impedance state.
- These parameters are guaranteed by design and are not tested.
- The internal write time of the memory is defined by the overlap of \overline{CE} and \overline{WE} LOW. Chip enable must be active and \overline{WE} and byte enables must be LOW to initiate a write, and the transition of any of these signals terminate the write. The input data setup and hold timing are referenced to the leading edge of the signal that terminates the write.
- The minimum write cycle pulse width for Write Cycle No. 2 (\overline{WE} Controlled, \overline{OE} LOW) should be equal to sum of t_{HZWE} and t_{SD} .

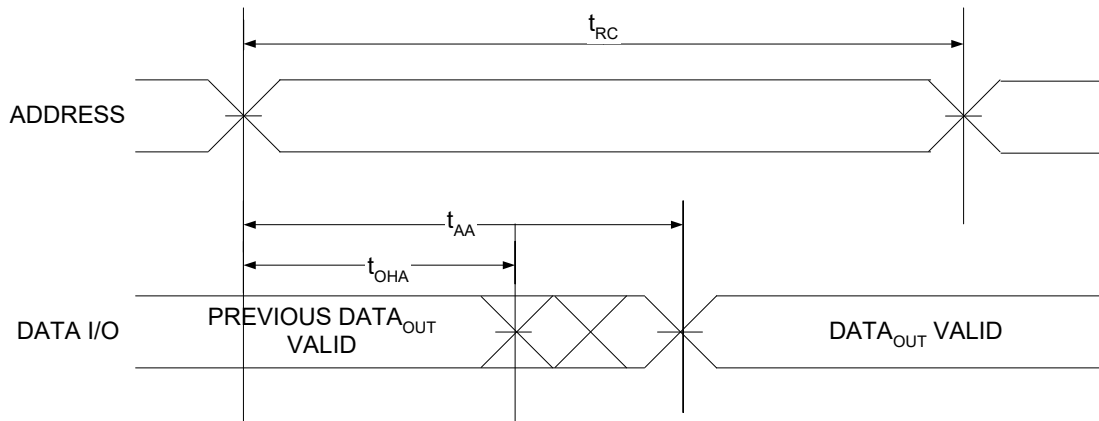
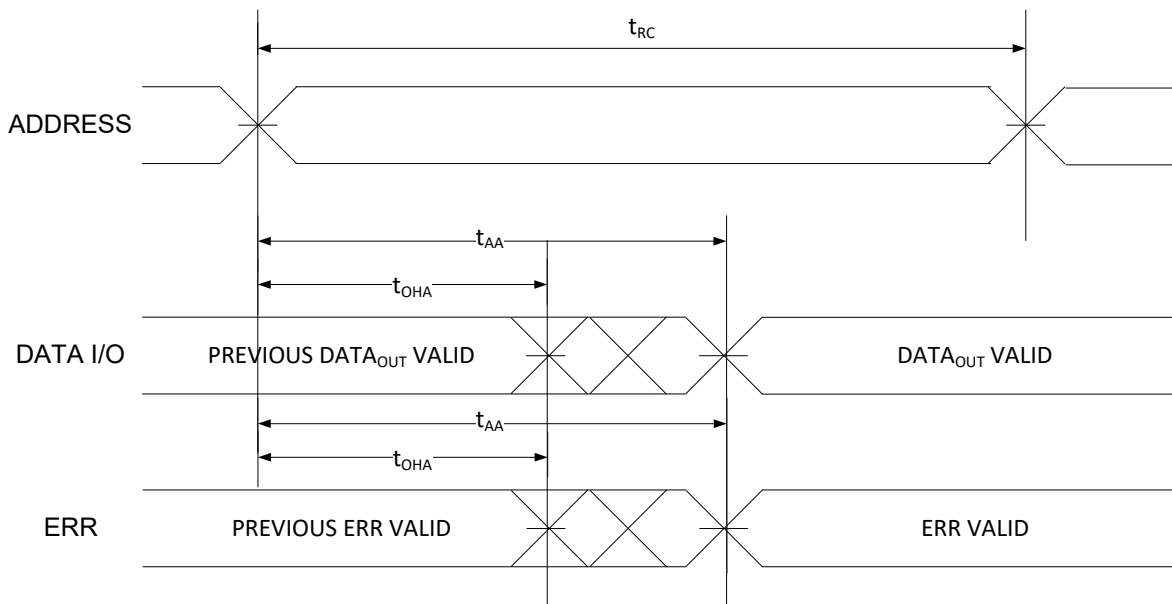
Switching Waveforms**Figure 5. Read Cycle No. 1 of CY62162G (Address Transition Controlled)** [23, 24]**Figure 6. Read Cycle No. 1 of CY62162GE (Address Transition Controlled)** [23, 24]**Notes**

23. Device is continuously selected. $\overline{OE} = V_{IL}$, $\overline{CE} = V_{IL}$.
 24. WE is HIGH for read cycle.

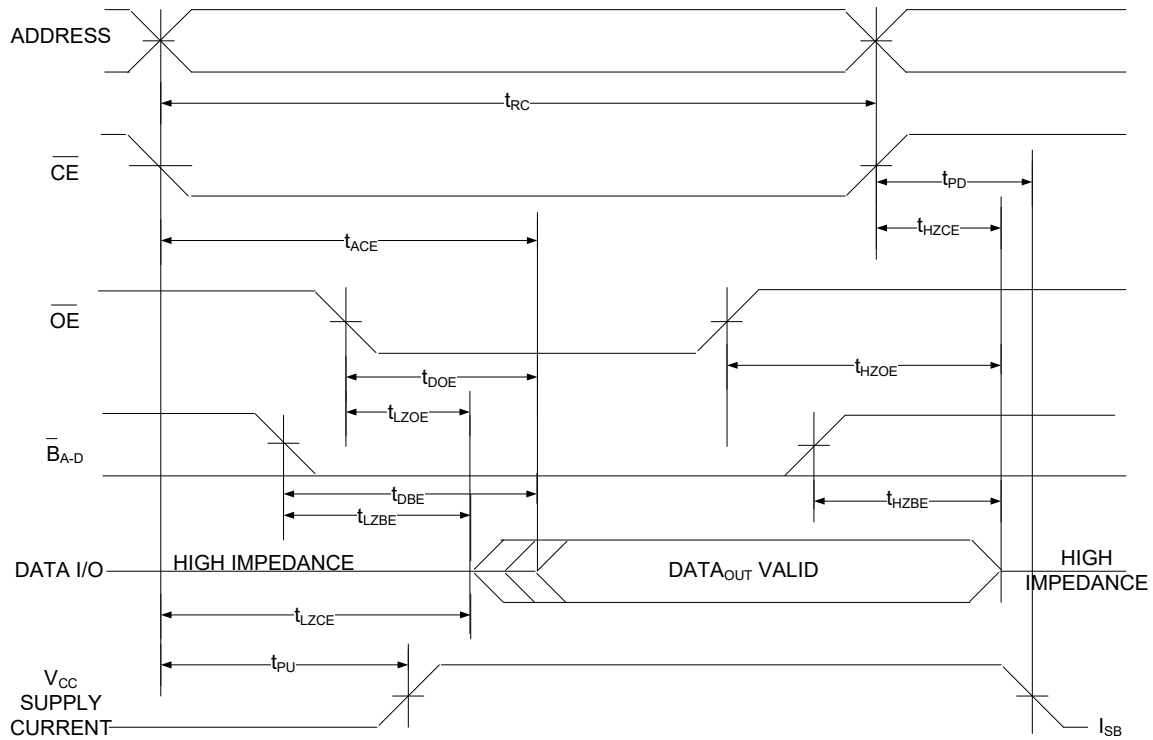

Switching Waveforms (continued)

Figure 7. Read Cycle No. 2 ($\overline{\text{OE}}$ Controlled) [25, 26, 27]

Notes

25. $\overline{\text{WE}}$ is HIGH for read cycle.

26. Address valid before or similar to $\overline{\text{CE}}$ transition LOW.

27. $\overline{\text{CE}}$ refers to a combination of $\overline{\text{CE}}_1$ and CE_2 . $\overline{\text{CE}}$ is LOW when $\overline{\text{CE}}_1$ is LOW and CE_2 is HIGH. $\overline{\text{CE}}$ is HIGH when $\overline{\text{CE}}_1$ is HIGH or CE_2 is LOW.

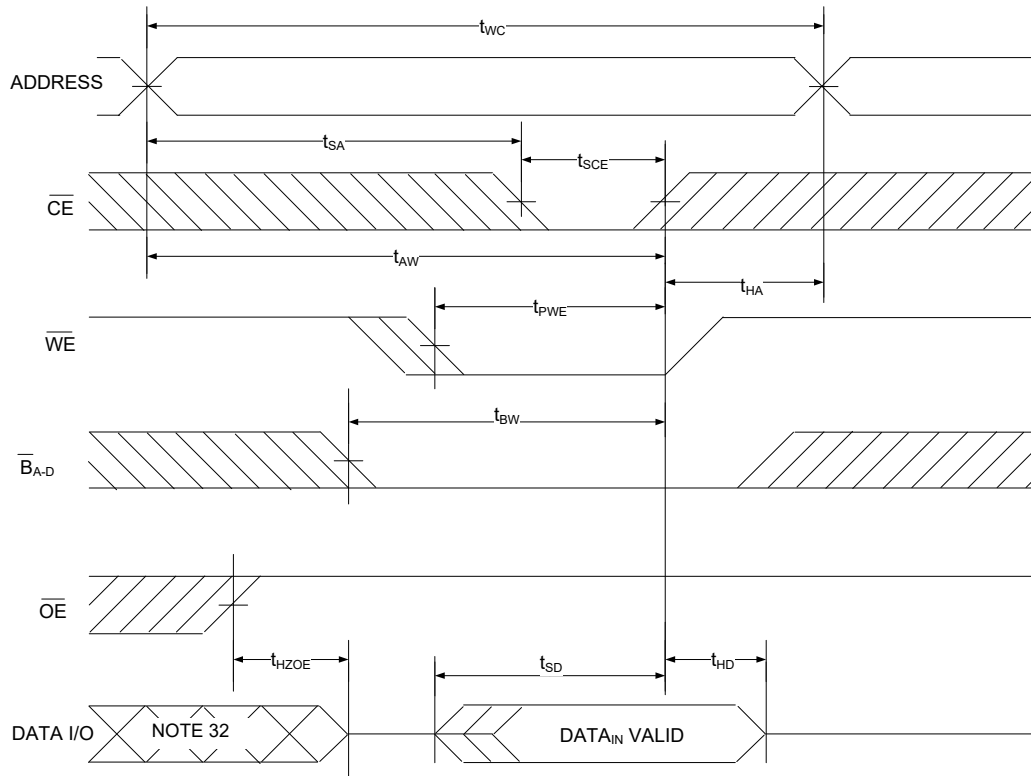

Switching Waveforms (continued)

Figure 8. Write Cycle No. 1 ($\overline{\text{CE}}$ Controlled) [28, 29, 30, 31]

Notes

28. The internal write time of the memory is defined by the overlap of $\overline{\text{CE}}$ and $\overline{\text{WE}}$ LOW. Chip enable must be active and $\overline{\text{WE}}$ and byte enables must be LOW to initiate a write, and the transition of any of these signals terminate the write. The input data setup and hold timing are referenced to the leading edge of the signal that terminates the write.

29. Data I/O is high impedance if $\overline{\text{OE}}$ or $\overline{\text{B}}_A$, $\overline{\text{B}}_B$, $\overline{\text{B}}_C$, $\overline{\text{B}}_D = V_{IH}$.

30. If $\overline{\text{CE}}$ goes HIGH simultaneously with $\overline{\text{WE}}$ going HIGH, the output remains in a high impedance state.

31. $\overline{\text{CE}}$ refers to a combination of $\overline{\text{CE}}_1$ and CE_2 . $\overline{\text{CE}}$ is LOW when $\overline{\text{CE}}_1$ is LOW and CE_2 is HIGH. $\overline{\text{CE}}$ is HIGH when $\overline{\text{CE}}_1$ is HIGH or CE_2 is LOW.

32. During this period the I/Os are in output state and input signals should not be applied.

Switching Waveforms (continued)

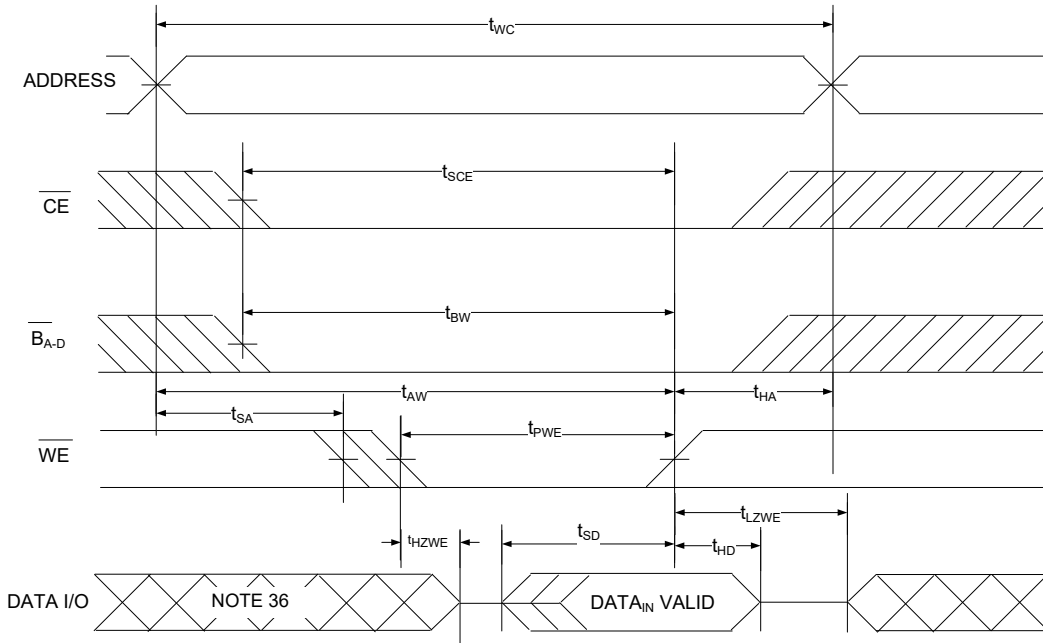
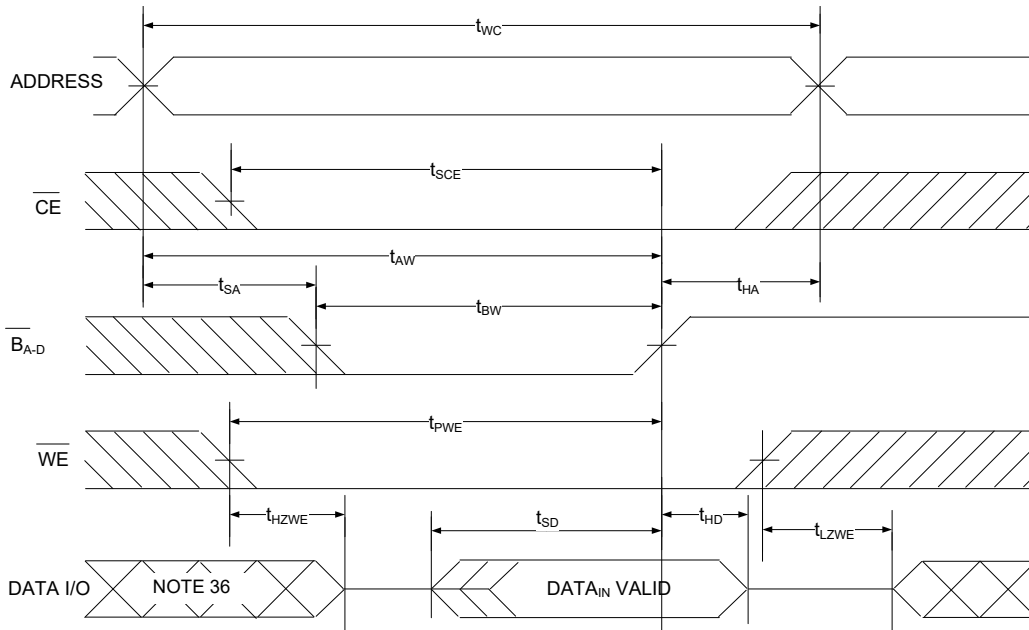
Figure 9. Write Cycle No. 2 (\overline{WE} Controlled, \overline{OE} LOW) [33, 34, 35]Figure 10. Write Cycle No. 3 (\overline{BA} , \overline{BB} , \overline{BC} , \overline{BD} Controlled, \overline{OE} LOW) [33, 34]

Notes

33. If \overline{CE} goes HIGH simultaneously with \overline{WE} going HIGH, the output remains in a high impedance state.

34. \overline{CE} refers to a combination of \overline{CE}_1 and CE_2 . \overline{CE} is LOW when \overline{CE}_1 is LOW and CE_2 is HIGH. \overline{CE} is HIGH when \overline{CE}_1 is HIGH or CE_2 is LOW.

35. The minimum write cycle pulse width should be equal to the sum of t_{HZWE} and t_{SD} .

36. During this period the I/Os are in output state and input signals should not be applied.



Truth Table – CY62162G/CY62162GE

$\overline{CE}^{[37]}$	\overline{OE}	\overline{WE}	\overline{B}_A	\overline{B}_B	\overline{B}_C	\overline{B}_D	I/O ₀ –I/O ₇	I/O ₈ –I/O ₁₅	I/O ₁₆ –I/O ₂₃	I/O ₂₄ –I/O ₃₁	Mode	Power
H	X	X	X ^[38]	X ^[38]	X ^[38]	X ^[38]	High Z	High Z	High Z	High Z	Standby	(I _{SB})
X ^[38]	X	X	H	H	H	H	High Z	High Z	High Z	High Z	Standby	(I _{SB})
L	L	H	L	L	L	L	Data out	Data out	Data out	Data out	Read all bits	(I _{CC})
L	L	H	L	H	H	H	Data out	High Z	High Z	High Z	Read byte A bits only	(I _{CC})
L	L	H	H	L	H	H	High Z	Data out	High Z	High Z	Read byte B bits only	(I _{CC})
L	L	H	H	H	L	H	High Z	High Z	Data out	High Z	Read byte C bits only	(I _{CC})
L	L	H	H	H	H	L	High Z	High Z	High Z	Data out	Read byte D bits only	(I _{CC})
L	X	L	L	L	L	L	Data in	Data in	Data in	Data in	Write all bits	(I _{CC})
L	X	L	L	H	H	H	Data in	High Z	High Z	High Z	Write byte A bits only	(I _{CC})
L	X	L	H	L	H	H	High Z	Data in	High Z	High Z	Write byte B bits only	(I _{CC})
L	X	L	H	H	L	H	High Z	High Z	Data in	High Z	Write byte C bits only	(I _{CC})
L	X	L	H	H	H	L	High Z	High Z	High Z	Data in	Write byte D bits only	(I _{CC})
L	H	H	X ^[38]	X ^[38]	X ^[38]	X ^[38]	High Z	High Z	High Z	High Z	Selected, outputs disabled	(I _{CC})

ERR Output – CY62162GE

Output ^[39]	Mode
0	Read Operation, no single bit error in the stored data.
1	Read Operation, single bit error detected and corrected.
Z	Device deselected / Outputs disabled / Write Operation.

Note

37. \overline{CE} refers to a combination of \overline{CE}_1 and CE_2 . \overline{CE} is LOW when \overline{CE}_1 is LOW and CE_2 is HIGH. \overline{CE} is HIGH when \overline{CE}_1 is HIGH or CE_2 is LOW.

38. 'X' refers to V_{IL} or V_{IH} . For CMOS voltage levels refer to I_{SB2} test conditions in [Electrical Characteristics on page 6](#). Chip enables (\overline{CE}_1 and CE_2) and all Byte Enables (\overline{B}_{A-D}) must be in CMOS voltage levels to meet the I_{SB2}/I_{CCDR} spec.

39. ERR is an Output pin. If not used, this pin should be left floating.



CY62162G/CY62162GE MoBL

Ordering Information

Speed (ns)	Voltage Range	Ordering Code	Package Diagram	Package Type (All Pb-free)	Operating Range
45	2.2 V–3.6 V	CY62162G30-45BGXI	51-85115	119-ball PBGA (14 × 22 × 2.4 mm)	Industrial
55	1.65 V–2.2 V	CY62162G18-55BGXI			Industrial

Ordering Code Definitions

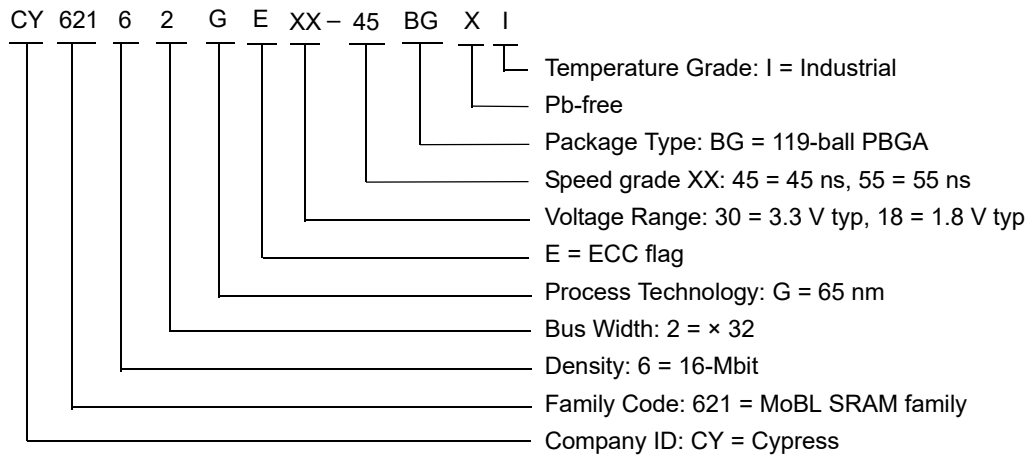



CY62162G/CY62162GE MoBL

Package Diagram

Figure 11. 119-ball PBGA (14 × 22 × 2.4 mm) Package Outline, 51-85115

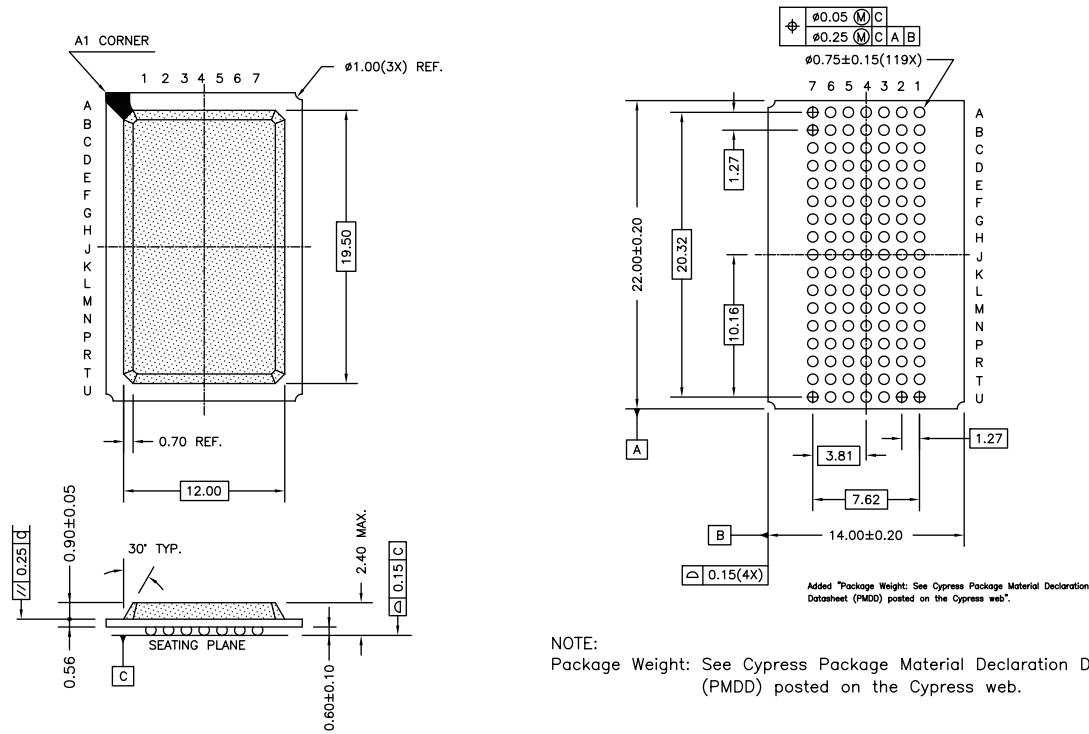

51-85115 *D



Acronyms

Acronym	Description
\overline{CE}	Chip Enable
CMOS	Complementary Metal Oxide Semiconductor
FBGA	Fine-Pitch Ball Grid Array
I/O	Input/Output
\overline{OE}	Output Enable
SRAM	Static Random Access Memory
\overline{WE}	Write Enable

Document Conventions

Units of Measure

Symbol	Unit of Measure
$^{\circ}C$	degree Celsius
mA	milliampere
MHz	megahertz
mm	millimeter
μA	microampere
μs	microsecond
ns	nanosecond
Ω	ohm
%	percent
pF	picofarad
V	volt
W	watt



Document History Page

Document Title: CY62162G/CY62162GE MoBL, 16-Mbit (512K × 32) Static RAM with Error-Correcting Code (ECC) Document Number: 001-81598			
Revision	ECN	Submission Date	Description of Change
*C	4863821	07/31/2015	Changed status from Preliminary to Final.
*D	6012120	01/03/2018	Updated Cypress Logo and Copyright.
*E	6674948	09/27/2019	<p>Updated Product Portfolio: Added Note "This device is offered with improved I_{CC}, I_{SB1} and I_{SB2} specifications compared to the current revision with same marketing part number. The new device will be in production from WW1952. For more information, please contact Cypress sales representative." and referred the same note in "CY62162G(E)30" under "Product" column. Added Note "For next version of this device, kindly refer here. Further details about improvement and comparison between current and new versions can be found in the PCN193805." and referred the same note in "CY62162G(E)30" under "Product" column.</p> <p>Updated Pin Configurations: Updated Figure 1. Updated Figure 2.</p> <p>Updated Electrical Characteristics: Added Note "This device is offered with improved I_{CC}, I_{SB1} and I_{SB2} specifications compared to the current revision with same marketing part number. The new device will be in production from WW1952. For more information, please contact Cypress sales representative." and referred the same note in I_{CC}, I_{SB1}, I_{SB2} parameters. Added Note "For next version of this device, kindly refer here. Further details about improvement and comparison between current and new versions can be found in the PCN193805." and referred the same note in I_{CC}, I_{SB1}, I_{SB2} parameters.</p> <p>Updated Data Retention Characteristics: Added Note "This device is offered with improved I_{CC}, I_{SB1} and I_{SB2} specifications compared to the current revision with same marketing part number. The new device will be in production from WW1952. For more information, please contact Cypress sales representative." and referred the same note in I_{CCDR} parameter. Added Note "For next version of this device, kindly refer here. Further details about improvement and comparison between current and new versions can be found in the PCN193805." and referred the same note in I_{CCDR} parameter.</p> Updated to new template. Completing Sunset Review.
*F	6822780	03/02/2020	<p>Updated Product Portfolio: Removed Note "This device is offered with improved I_{CC}, I_{SB1} and I_{SB2} specifications compared to the current revision with same marketing part number. The new device will be in production from WW1952. For more information, please contact Cypress sales representative." and its reference in "CY62162G(E)30" under "Product" column. Removed Note "For next version of this device, kindly refer here. Further details about improvement and comparison between current and new versions can be found in the PCN193805." and its reference in "CY62162G(E)30" under "Product" column.</p> <p>Updated Electrical Characteristics: Removed Note "This device is offered with improved I_{CC}, I_{SB1} and I_{SB2} specifications compared to the current revision with same marketing part number. The new device will be in production from WW1952. For more information, please contact Cypress sales representative." and its reference in I_{CC}, I_{SB1}, I_{SB2} parameters. Removed Note "For next version of this device, kindly refer here. Further details about improvement and comparison between current and new versions can be found in the PCN193805." and its reference in I_{CC}, I_{SB1}, I_{SB2} parameters.</p>



Document History Page *(continued)*

Document Title: CY62162G/CY62162GE MoBL, 16-Mbit (512K × 32) Static RAM with Error-Correcting Code (ECC) Document Number: 001-81598			
Revision	ECN	Submission Date	Description of Change
*F (cont.)	6822780	03/02/2020	<p>Updated Data Retention Characteristics:</p> <p>Removed Note “This device is offered with improved I_{CC}, I_{SB1} and I_{SB2} specifications compared to the current revision with same marketing part number. The new device will be in production from WW1952. For more information, please contact Cypress sales representative.” and its reference in I_{CCDR} parameter.</p> <p>Removed Note “For next version of this device, kindly refer here. Further details about improvement and comparison between current and new versions can be found in the PCN193805.” and its reference in I_{CCDR} parameter.</p> <p>Updated to new template.</p>



Sales, Solutions, and Legal Information

Worldwide Sales and Design Support

Cypress maintains a worldwide network of offices, solution centers, manufacturer's representatives, and distributors. To find the office closest to you, visit us at [Cypress Locations](#).

Products

Arm® Cortex® Microcontrollers	cypress.com/arm
Automotive	cypress.com/automotive
Clocks & Buffers	cypress.com/clocks
Interface	cypress.com/interface
Internet of Things	cypress.com/iot
Memory	cypress.com/memory
Microcontrollers	cypress.com/mcu
PSoC	cypress.com/psoc
Power Management ICs	cypress.com/pmic
Touch Sensing	cypress.com/touch
USB Controllers	cypress.com/usb
Wireless Connectivity	cypress.com/wireless

PSoC® Solutions

[PSoC 1](#) | [PSoC 3](#) | [PSoC 4](#) | [PSoC 5LP](#) | [PSoC 6 MCU](#)

Cypress Developer Community

[Community](#) | [Code Examples](#) | [Projects](#) | [Video](#) | [Blogs](#) | [Training](#) | [Components](#)

Technical Support

cypress.com/support

© Cypress Semiconductor Corporation, 2012–2020. This document is the property of Cypress Semiconductor Corporation and its subsidiaries ("Cypress"). This document, including any software or firmware included or referenced in this document ("Software"), is owned by Cypress under the intellectual property laws and treaties of the United States and other countries worldwide. Cypress reserves all rights under such laws and treaties and does not, except as specifically stated in this paragraph, grant any license under its patents, copyrights, trademarks, or other intellectual property rights. If the Software is not accompanied by a license agreement and you do not otherwise have a written agreement with Cypress governing the use of the Software, then Cypress hereby grants you a personal, non-exclusive, nontransferable license (without the right to sublicense) (1) under its copyright rights in the Software (a) for Software provided in source code form, to modify and reproduce the Software solely for use with Cypress hardware products, only internally within your organization, and (b) to distribute the Software in binary code form externally to end users (either directly or indirectly through resellers and distributors), solely for use on Cypress hardware product units, and (2) under those claims of Cypress's patents that are infringed by the Software (as provided by Cypress, unmodified) to make, use, distribute, and import the Software solely for use with Cypress hardware products. Any other use, reproduction, modification, translation, or compilation of the Software is prohibited.

TO THE EXTENT PERMITTED BY APPLICABLE LAW, CYPRESS MAKES NO WARRANTY OF ANY KIND, EXPRESS OR IMPLIED, WITH REGARD TO THIS DOCUMENT OR ANY SOFTWARE OR ACCOMPANYING HARDWARE, INCLUDING, BUT NOT LIMITED TO, THE IMPLIED WARRANTIES OF MERCHANTABILITY AND FITNESS FOR A PARTICULAR PURPOSE. No computing device can be absolutely secure. Therefore, despite security measures implemented in Cypress hardware or software products, Cypress shall have no liability arising out of any security breach, such as unauthorized access to or use of a Cypress product. CYPRESS DOES NOT REPRESENT, WARRANT, OR GUARANTEE THAT CYPRESS PRODUCTS, OR SYSTEMS CREATED USING CYPRESS PRODUCTS, WILL BE FREE FROM CORRUPTION, ATTACK, VIRUSES, INTERFERENCE, HACKING, DATA LOSS OR THEFT, OR OTHER SECURITY INTRUSION (collectively, "Security Breach"). Cypress disclaims any liability relating to any Security Breach, and you shall and hereby do release Cypress from any claim, damage, or other liability arising from any Security Breach. In addition, the products described in these materials may contain design defects or errors known as errata which may cause the product to deviate from published specifications. To the extent permitted by applicable law, Cypress reserves the right to make changes to this document without further notice. Cypress does not assume any liability arising out of the application or use of any product or circuit described in this document. Any information provided in this document, including any sample design information or programming code, is provided only for reference purposes. It is the responsibility of the user of this document to properly design, program, and test the functionality and safety of any application made of this information and any resulting product. "High-Risk Device" means any device or system whose failure could cause personal injury, death, or property damage. Examples of High-Risk Devices are weapons, nuclear installations, surgical implants, and other medical devices. "Critical Component" means any component of a High-Risk Device whose failure to perform can be reasonably expected to cause, directly or indirectly, the failure of the High-Risk Device, or to affect its safety or effectiveness. Cypress is not liable, in whole or in part, and you shall and hereby do release Cypress from any claim, damage, or other liability arising from any use of a Cypress product as a Critical Component in a High-Risk Device. You shall indemnify and hold Cypress, its directors, officers, employees, agents, affiliates, distributors, and assigns harmless from and against all claims, costs, damages, and expenses, arising out of any claim, including claims for product liability, personal injury or death, or property damage arising from any use of a Cypress product as a Critical Component in a High-Risk Device. Cypress products are not intended or authorized for use as a Critical Component in any High-Risk Device except to the limited extent that (i) Cypress's published data sheet for the product explicitly states Cypress has qualified the product for use in a specific High-Risk Device, or (ii) Cypress has given you advance written authorization to use the product as a Critical Component in the specific High-Risk Device and you have signed a separate indemnification agreement.

Cypress, the Cypress logo, Spansion, the Spansion logo, and combinations thereof, WICED, PSoC, CapSense, EZ-USB, F-RAM, and Traveo are trademarks or registered trademarks of Cypress in the United States and other countries. For a more complete list of Cypress trademarks, visit cypress.com. Other names and brands may be claimed as property of their respective owners.

OUR CERTIFICATE

DiGi provide top-quality products and perfect service for customer worldwide through standardization, technological innovation and continuous improvement. DiGi through third-party certification, we stricly control the quality of products and services. Welcome your RFQ to

Email: Info@DiGi-Electronics.com



Tel: +00 852-30501935

RFQ Email: Info@DiGi-Electronics.com

DiGi is a global authorized distributor of electronic components.