

CY62167ESL-55FNXIT Datasheet



<https://www.DiGi-Electronics.com>

DiGi Electronics Part Number	CY62167ESL-55FNXIT-DG
Manufacturer	Infineon Technologies
Manufacturer Product Number	CY62167ESL-55FNXIT
Description	IC SRAM 16MBIT PARALLEL 60WLCSP
Detailed Description	SRAM - Asynchronous Memory IC 16Mbit Parallel 55 ns 60-WLCSP (5.81x4.65)

This model CY62167ESL-55FNXIT is available at DiGi Electronics.

DiGi Electronics offers a global database of semiconductor and electronic component datasheets.

We welcome your inquiries regarding pricing, lead time, or other product-related questions.

 [Request a Quote](#)

 [Datasheet Search](#)



Tel: +00 852-30501935

RFQ Email: Info@DiGi-Electronics.com

DiGi is a global authorized distributor of electronic components.

Purchase and inquiry

Manufacturer Product Number:

CY62167ESL-55FNXIT

Series:

MoBL®

DiGi-Electronics Programmable:

Not Verified

Memory Format:

SRAM

Memory Size:

16Mbit

Memory Interface:

Parallel

Access Time:

55 ns

Operating Temperature:

-40°C ~ 85°C (TA)

Package / Case:

60-UFBGA, WLCSP

Base Product Number:

CY62167

Manufacturer:

Infineon Technologies

Product Status:

Obsolete

Memory Type:

Volatile

Technology:

SRAM - Asynchronous

Memory Organization:

2M x 8, 1M x 16

Write Cycle Time - Word, Page:

55ns

Voltage - Supply:

1.65V ~ 1.95V

Mounting Type:

Surface Mount

Supplier Device Package:

60-WLCSP (5.81x4.65)

Environmental & Export classification

RoHS Status:

ROHS3 Compliant

REACH Status:

REACH Unaffected

HTSUS:

8542.32.0041

Moisture Sensitivity Level (MSL):

1 (Unlimited)

ECCN:

3A991B2A



CY62167ESL MoBL®

16-Mbit (1 M × 16) Static RAM

Features

- High speed: 45 ns/55 ns
- Temperature range:
 - Industrial: -40 °C to +85 °C
- Wide voltage range: 1.65 V to 1.95 V, 2.2 V to 3.6 V and 4.5 V to 5.5 V
- Ultra-low standby power
 - Typical standby current at 25 °C = 1.5 μA
 - Typical standby current at 40 °C = 2.5 μA
- Ultra-low active power
 - Active current: I_{CC} = 2.2 mA (typical) at f = 1 MHz
- Easy memory expansion with \overline{CE}_1 , CE₂, and \overline{OE} Features
- Automatic power-down when deselected
- CMOS for optimum speed and power
- Pb-free 60-pin WLCSP packages

Functional Description

The CY62167ESL is a high-performance CMOS Static RAM organized as 1M words by 16 bits. This device features an advanced circuit design that provides an ultra low active current. Ultra low active current is ideal for providing More Battery Life™ (MoBL®) in portable applications such as hand-held devices. The device also has an automatic power-down feature that

reduces power consumption by 99% when addresses are not toggling. Place the device into standby mode when deselected (CE₁ HIGH or CE₂ LOW or both BHE and BLE are HIGH).

The input and output pins (I/O₀ through I/O₁₅) are placed in a high impedance state during the following events:

- The device is deselected (\overline{CE}_1 HIGH or CE₂ LOW)
- Outputs are disabled (\overline{OE} HIGH)
- Byte High Enable and Byte Low Enable are disabled (\overline{BHE} , BLE HIGH), or a write operation is in progress (CE₁ LOW, CE₂ HIGH and WE LOW)

Write to the device by taking Chip Enable (\overline{CE}_1 LOW and CE₂ HIGH) and Write Enable (WE) inputs LOW. If Byte Low Enable (BLE) is LOW, then data from I/O pins (I/O₀ through I/O₇) is written into the location specified on the address pins (A₀ through A₁₉). If Byte High Enable (BHE) is LOW, then data from the I/O pins (I/O₈ through I/O₁₅) is written into the location specified on the address pins (A₀ through A₁₉).

Read from the device by taking Chip Enables (\overline{CE}_1 LOW and CE₂ HIGH) and Output Enable (\overline{OE}) LOW while forcing the Write Enable (WE) HIGH. If Byte Low Enable (BLE) is LOW, then data from the memory location specified by the address pins appears on I/O₀ to I/O₇. If Byte High Enable (\overline{BHE}) is LOW, then data from memory appears on I/O₈ to I/O₁₅. See Truth Table on page 12 for a complete description of read and write modes.

Logic Block Diagram – CY62167ESL

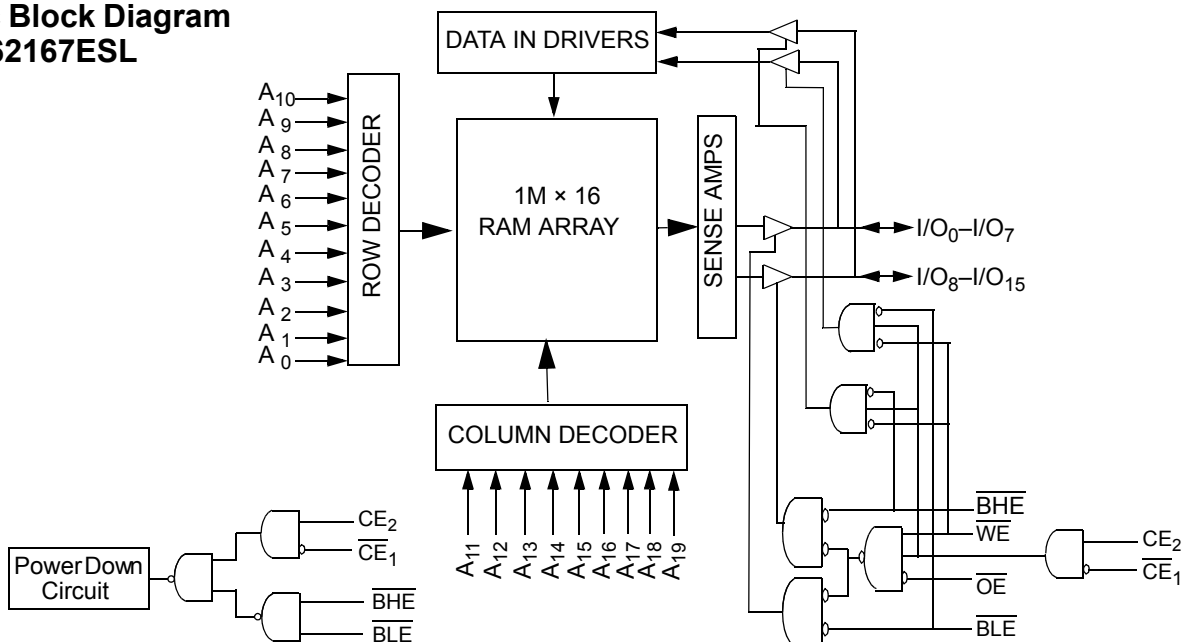



Contents

Pin Configurations	3	Ordering Information	13
Product Portfolio	3	Ordering Code Definitions	13
Maximum Ratings	4	Package Diagram	14
Operating Range	4	Acronyms	15
DC Electrical Characteristics	4	Document Conventions	15
Capacitance	5	Units of Measure	15
Thermal Resistance	5	Document History Page	16
AC Test Loads and Waveforms	5	Sales, Solutions, and Legal Information	17
Data Retention Characteristics	6	Worldwide Sales and Design Support	17
Data Retention Waveform	6	Products	17
AC Switching Characteristics	7	PSoC [®] Solutions	17
Switching Waveforms	8	Cypress Developer Community	17
Truth Table	12	Technical Support	17

Pin Configurations

Figure 1. 60-Pin WLCSP Pinout (Ball Up View)^[1]

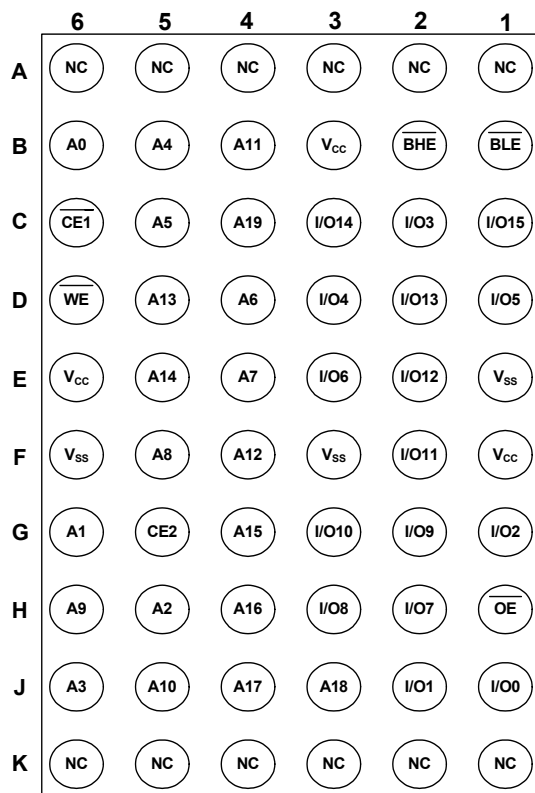
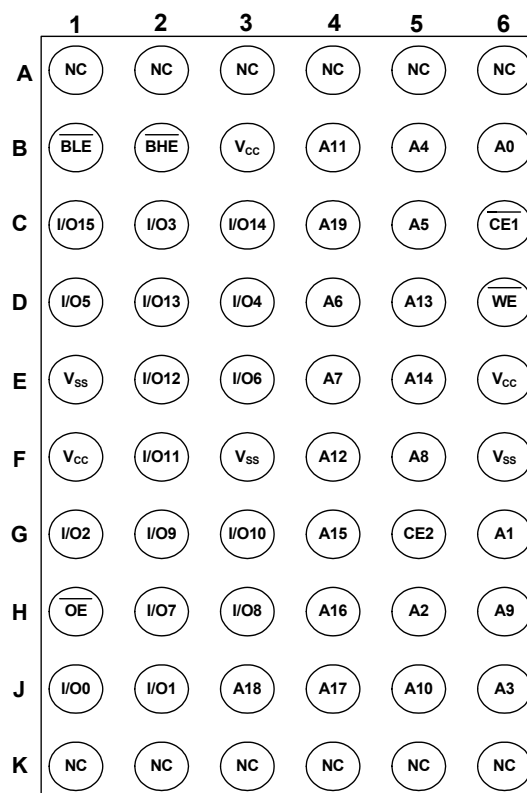

Figure 2. 60-Pin WLCSP Pinout (Ball Down View)^[1]



Product Portfolio

Product	Range	V _{CC} Range (V)			Speed (ns)	Power Dissipation					
						Operating I _{CC} (mA)				Standby I _{SB2} (μA)	
		f = 1 MHz		f = f _{max}							
		Min	Typ	Max		Typ	Max	Typ	Max	Typ	Max
CY62167ESL	Industrial	4.5	5.0	5.5	45	2.2	4.0	25	30	1.5	12
		2.2	3.0	3.6							
		1.65	1.8	1.95	55						

Notes

- NC pins are not connected on the die.



Maximum Ratings

Exceeding maximum ratings may shorten the useful life of device. User guidelines are not tested.

Storage temperature -65 °C to + 150 °C

Ambient temperature with power applied -55 °C to + 125 °C

Supply voltage to ground potential [2, 3] -0.5 V to 6.0 V

DC voltage applied to outputs in High Z state [2, 3] -0.5 V to $V_{CC} + 0.5$ V

DC input voltage [2, 3] -0.5 V to $V_{CC} + 0.5$ V

Output current into outputs (LOW) 20 mA

Static discharge voltage (MIL-STD-883, Method 3015) >2001 V

Latch-up current >200 mA

Operating Range

Device	Range	Ambient Temperature	V_{CC} [4]
CY62167ESL	Industrial	-40 °C to +85 °C	1.65 V to 1.95 V, 2.2 V to 3.6 V, 4.5 V to 5.5 V

DC Electrical Characteristics

Over the operating range of -40 °C to 85 °C

Parameter	Description	Test Conditions		45/55 ns			Unit
				Min	Typ [5]	Max	
V_{OH}	Output HIGH Voltage	$1.65 \leq V_{CC} \leq 1.95$	$I_{OH} = -0.1$ mA	1.4	-	-	V
		$2.2 \leq V_{CC} \leq 2.7$	$I_{OH} = -0.1$ mA	2.0	-	-	
		$2.7 \leq V_{CC} \leq 3.6$	$I_{OH} = -1.0$ mA	2.4	-	-	
		$4.5 \leq V_{CC} \leq 5.5$	$I_{OH} = -1.0$ mA	2.4	-	-	
V_{OL}	Output LOW Voltage	$1.65 \leq V_{CC} \leq 1.95$	$I_{OL} = 0.1$ mA	-	-	0.2	
		$2.2 \leq V_{CC} \leq 2.7$	$I_{OL} = 0.1$ mA	-	-	0.4	
		$2.7 \leq V_{CC} \leq 3.6$	$I_{OL} = 2.1$ mA	-	-	0.4	
		$4.5 \leq V_{CC} \leq 5.5$	$I_{OL} = 2.1$ mA	-	-	0.4	
V_{IH}	Input HIGH Voltage	$1.65 \leq V_{CC} \leq 1.95$		1.4	-	$V_{CC} + 0.2$	
		$2.2 \leq V_{CC} \leq 2.7$		1.8	-	$V_{CC} + 0.3$	
		$2.7 \leq V_{CC} \leq 3.6$		2.2	-	$V_{CC} + 0.3$	
		$4.5 \leq V_{CC} \leq 5.5$		2.2	-	$V_{CC} + 0.5$	
V_{IL}	Input LOW Voltage	$1.65 \leq V_{CC} \leq 1.95$		-0.2	-	0.4	
		$2.2 \leq V_{CC} \leq 2.7$		-0.3	-	0.6	
		$2.7 \leq V_{CC} \leq 3.6$		-0.3	-	0.8	
		$4.5 \leq V_{CC} \leq 5.5$		-0.5	-	0.8	
I_{IX}	Input Leakage Current	$GND \leq V_I \leq V_{CC}$		-1.0	-	+1.0	μ A
I_{OZ}	Output Leakage Current	$GND \leq V_O \leq V_{CC}$, Output disabled		-1.0	-	+1.0	
I_{CC}	V_{CC} Operating Supply Current	$f = f_{max} = 1/t_{RC}$	$V_{CC} = V_{CC Max}$.	-	25.0	30.0	mA
		$f = 1$ MHz	$I_{OUT} = 0$ mA, CMOS levels	-	2.2	4.0	
I_{SB1} [6]	Automatic CE Power-down Current – CMOS Inputs	$\overline{CE}_1 \geq V_{CC} - 0.2$ V or $CE_2 \leq 0.2$ V or $(\overline{BHE}$ and $\overline{BLE}) \geq V_{CC} - 0.2$ V, $V_{IN} \geq V_{CC} - 0.2$ V, $V_{IN} \leq 0.2$ V, $f = f_{max}$ (address and data only), $f = 0$ (OE, and WE), $V_{CC} = V_{CC(max)}$		-	-	12.0	μ A
I_{SB2} [6]	Automatic CE Power-down Current – CMOS Inputs	or \overline{BHE} and $\overline{BLE} \geq V_{CC} - 0.2$ V, $V_{IN} \geq V_{CC} - 0.2$ V or $V_{IN} \leq 0.2$ V, $f = 0$, $V_{CC} = V_{CC(max)}$		25 °C [5]	1.5	4.0	
				40 °C [5]	2.5	7.0	
				85 °C	-	12.0	

Notes

- $V_{IL(min)}$ = -2.0 V for pulse durations less than 20 ns.
- $V_{IH(max)}$ = $V_{CC} + 0.75$ V for pulse durations less than 20 ns.
- Full Device AC operation assumes a 100 μ s ramp time from 0 to $V_{CC(min)}$ and 200 μ s wait time after V_{CC} stabilization.
- These values are included for reference only and are not guaranteed or tested. Typical values are measured at $V_{CC} = V_{CC(typ)}$, $T_A = 25$ °C.
- Chip enables (CE_1 and CE_2) and byte enables (BHE and BLE) must be tied to CMOS levels to meet the $I_{SB1}/I_{SB2}/I_{CCDR}$ spec. Other inputs can be left floating.

Capacitance

Parameter ^[7]	Description	Test Conditions	Max	Unit
C _{IN}	Input Capacitance	T _A = 25 °C, f = 1 MHz, V _{CC} = V _{CC(typ)}	10.0	pF
C _{OUT}	Output Capacitance		10.0	pF

Thermal Resistance

Parameter ^[7]	Description	Test Conditions	WLCSP Package	Unit
θ _{JA}	Thermal resistance (junction to ambient)	Still Air, soldered on a 3 × 4.5 inch, four-layer printed circuit board	26.54	°C/W
θ _{JC}	Thermal resistance (junction to case)		0.11	°C/W

AC Test Loads and Waveforms

Figure 3. AC Test Loads and Waveforms

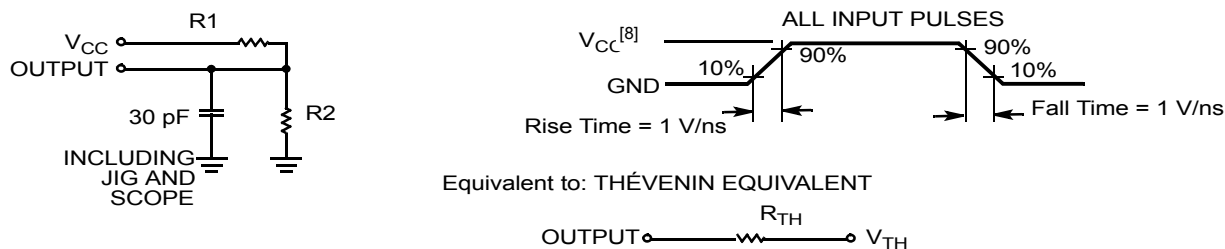

Parameters	1.65 V to 1.95 V	2.2 V to 2.7 V	2.7 V to 3.6 V	4.5 V to 5.5 V	Unit
R ₁	13500	16667	1103	1800	Ω
R ₂	10800	15385	1554	990	Ω
R _{TH}	6000	8000	645	639	Ω
V _{TH}	0.80	1.20	1.75	1.77	V

Notes

- Tested initially and after any design or process changes that may affect these parameters.
- Test conditions for all parameters other than tri-state parameters assume signal transition time of 1 V/ns, timing reference level of 1.5V (for V_{CC} > 3V) and V_{CC}/2 (for V_{CC} < 3V), and input pulse levels of 0 to 3V (for V_{CC} > 3V) and 0 to V_{CC} (V_{CC} < 3V) and output loading of the specified I_{OL}/I_{OH} as shown.

Data Retention Characteristics

Over the operating range of $-40\text{ }^{\circ}\text{C}$ to $85\text{ }^{\circ}\text{C}$

Parameter	Description	Conditions	Min	Typ ^[9]	Max	Unit
V_{DR}	V_{CC} for Data Retention	–	1.0	–	–	V
I_{CCDR} ^[10]	Data Retention Current	$V_{CC} = 1.0\text{ V}$, $\overline{CE}_1 \geq V_{CC} - 0.2\text{ V}$ or $CE_2 \leq 0.2\text{ V}$ or $(\overline{BHE}\text{ and } \overline{BLE}) \geq V_{CC} - 0.2\text{ V}$, $V_{IN} \geq V_{CC} - 0.2\text{ V}$ or $V_{IN} \leq 0.2\text{ V}$	–	–	10.0	μA
t_{CDR} ^[11]	Chip Deselect to Data Retention Time	–	0.0	–	–	–
t_R ^[12]	Operation Recovery Time	–	45/55	–	–	ns

Data Retention Waveform

Figure 4. Data Retention Waveform

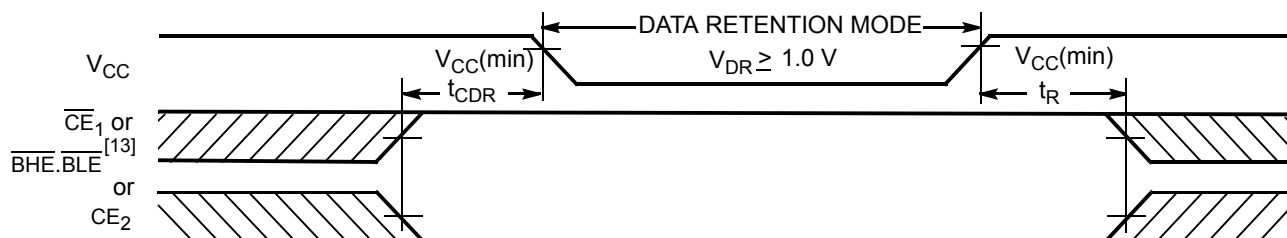

Notes

9. Typical values are included for reference only, and are not guaranteed or tested. Typical values are measured at $V_{CC} = V_{CC(typ)}$, $T_A = 25\text{ }^{\circ}\text{C}$.
10. Chip enables (\overline{CE}_1 and CE_2) and byte enables (\overline{BHE} and \overline{BLE}) must be tied to CMOS levels to meet the $I_{SB1} / I_{SB2} / I_{CCDR}$ spec. Other inputs can be left floating.
11. Tested initially and after any design or process changes that may affect these parameters.
12. Full device operation requires linear V_{CC} ramp from V_{DR} to $V_{CC(min)} \geq 100\text{ }\mu\text{s}$ or stable at $V_{CC(min)} \geq 100\text{ }\mu\text{s}$.
13. $\overline{BHE.BLE}$ is the AND of both \overline{BHE} and \overline{BLE} . Deselect the chip by either disabling the chip enable signals or by disabling both \overline{BHE} and \overline{BLE} .



AC Switching Characteristics

Over the operating range of -40 °C to 85 °C

Parameter [14, 15]	Description	45 ns		55 ns		Unit
		Min	Max	Min	Max	
Read Cycle						
t_{RC}	Read cycle time	45	–	55	–	ns
t_{AA}	Address to data valid	–	45	–	55	ns
t_{OHA}	Data hold from address change	10	–	10	–	ns
t_{ACE}	\overline{CE}_1 LOW and CE_2 HIGH to data valid	–	45	–	55	ns
t_{DOE}	\overline{OE} LOW to data valid	–	22	–	25	ns
t_{LZOE}	\overline{OE} LOW to Low Z [15]	5	–	5	–	ns
t_{HZOE}	\overline{OE} HIGH to High Z [15, 16]	–	18	–	18	ns
t_{LZCE}	\overline{CE}_1 LOW and CE_2 HIGH to Low Z [15]	10	–	10	–	ns
t_{HZCE}	\overline{CE}_1 HIGH and CE_2 LOW to High Z [15, 16]	–	18	–	18	ns
t_{PU}	\overline{CE}_1 LOW and CE_2 HIGH to power-up	0	–	0	–	ns
t_{PD}	\overline{CE}_1 HIGH and CE_2 LOW to power-down	–	45	–	55	ns
t_{DBE}	BLE / BHE LOW to data valid	–	45	–	55	ns
t_{LZBE}	\overline{BLE} / \overline{BHE} LOW to Low Z [15]	10	–	10	–	ns
t_{HZBE}	\overline{BLE} / \overline{BHE} HIGH to High Z [15, 16]	–	18	–	18	ns
Write Cycle [17, 18]						
t_{WC}	Write cycle time	45	–	55	–	ns
t_{SCE}	\overline{CE}_1 LOW and CE_2 HIGH to write end	35	–	40	–	ns
t_{AW}	Address setup to write end	35	–	40	–	ns
t_{HA}	Address hold from write end	0	–	0	–	ns
t_{SA}	Address setup to write start	0	–	0	–	ns
t_{PWE}	\overline{WE} pulse width	35	–	40	–	ns
t_{BW}	BLE / BHE LOW to write end	35	–	40	–	ns
t_{SD}	Data setup to write end	25	–	25	–	ns
t_{HD}	Data hold from write end	0	–	0	–	ns
t_{HZWE}	\overline{WE} LOW to High Z [15, 16]	–	18	–	20	ns
t_{LZWE}	\overline{WE} HIGH to Low Z [15]	10	–	10	–	ns

Notes

- Test conditions for all parameters other than tri-state parameters assume signal transition time of 1 V/ns, timing reference level of 1.5V (for $V_{CC} > 3V$) and $V_{CC}/2$ (for $V_{CC} < 3V$), and input pulse levels of 0 to 3V (for $V_{CC} > 3V$) and 0 to V_{CC} ($V_{CC} < 3V$) and output loading of the specified I_{OL}/I_{OH} as shown in Figure 3 on page 5.
- At any temperature and voltage condition, t_{HZCE} is less than t_{LZCE} , t_{HZBE} is less than t_{LZBE} , t_{HZOE} is less than t_{LZOE} , and t_{HZWE} is less than t_{LZWE} for any device.
- t_{HZOE} , t_{HZCE} , t_{HZBE} , and t_{HZWE} transitions are measured when the outputs enter a high impedance state.
- The internal write time of the memory is defined by the overlap of \overline{WE} , $\overline{CE}_1 = V_{IL}$, \overline{BHE} or \overline{BLE} or both = V_{IL} , and $CE_2 = V_{IH}$. All signals must be ACTIVE to initiate a write and any of these signals can terminate a write by going INACTIVE. The data input setup and hold timing must refer to the edge of the signal that terminates the write.
- The minimum pulse width for write cycle 3 (\overline{WE} controlled, \overline{OE} LOW) should be equal to the sum of t_{SD} and t_{HZWE} .

Switching Waveforms (continued)

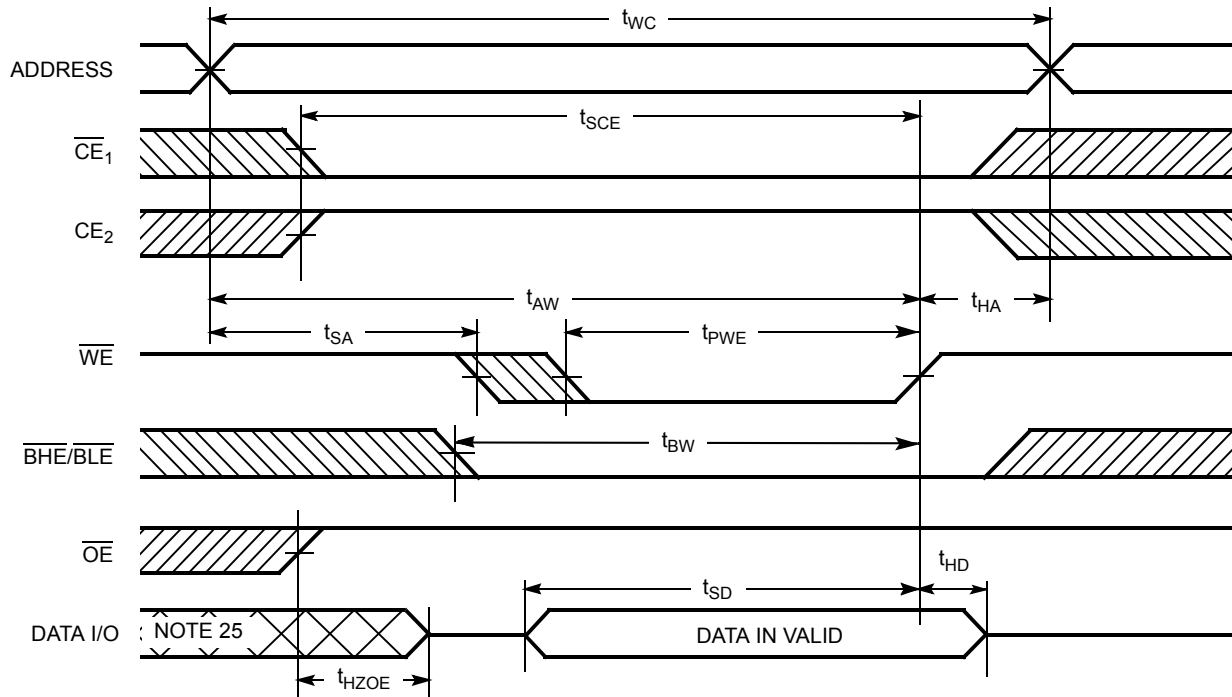
Figure 7. Write Cycle No. 1 ($\overline{\text{WE}}$ Controlled) [22, 23, 24]

Notes

22. The internal write time of the memory is defined by the overlap of $\overline{\text{WE}}$, $\overline{\text{CE}}_1 = V_{\text{IL}}$, $\overline{\text{BHE}}$ or $\overline{\text{BLE}}$ or both = V_{IL} , and $\text{CE}_2 = V_{\text{IH}}$. All signals must be ACTIVE to initiate a write and any of these signals can terminate a write by going INACTIVE. The data input setup and hold timing must refer to the edge of the signal that terminates the write.
23. Data I/O is high impedance if $\overline{\text{OE}} = V_{\text{IH}}$.
24. If $\overline{\text{CE}}_1$ goes HIGH and CE_2 goes LOW simultaneously with $\overline{\text{WE}} = V_{\text{IH}}$, the output remains in a high impedance state.
25. During this period, the I/Os are in output state. Do not apply input signals.

Switching Waveforms (continued)

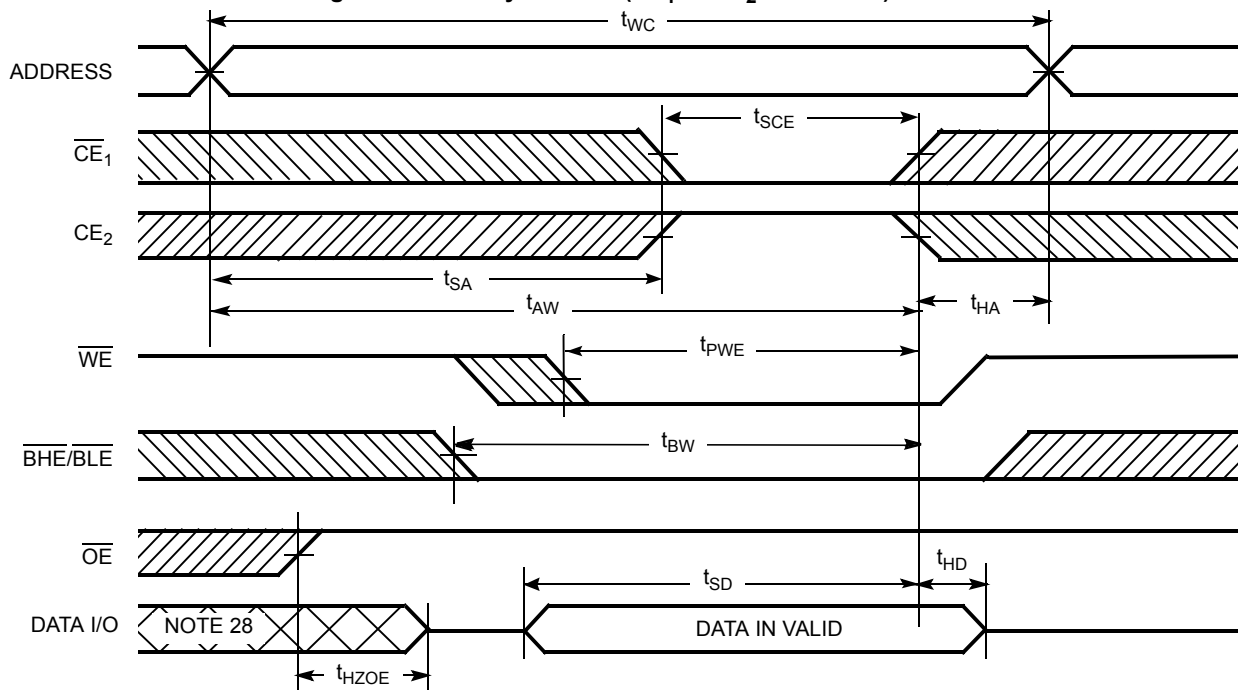
Figure 8. Write Cycle No. 2 (\overline{CE}_1 or CE_2 Controlled) [26, 27]

Notes

26. The internal write time of the memory is defined by the overlap of \overline{WE} , $\overline{CE}_1 = V_{IL}$, \overline{BHE} or \overline{BLE} or both = V_{IL} , and $CE_2 = V_{IH}$. All signals must be ACTIVE to initiate a write and any of these signals can terminate a write by going INACTIVE. The data input setup and hold timing must refer to the edge of the signal that terminates the write.
27. If \overline{CE}_1 goes HIGH and CE_2 goes LOW simultaneously with $\overline{WE} = V_{IH}$, the output remains in a high impedance state.
28. During this period the I/Os are in output state. Do not apply input signals.

Switching Waveforms (continued)

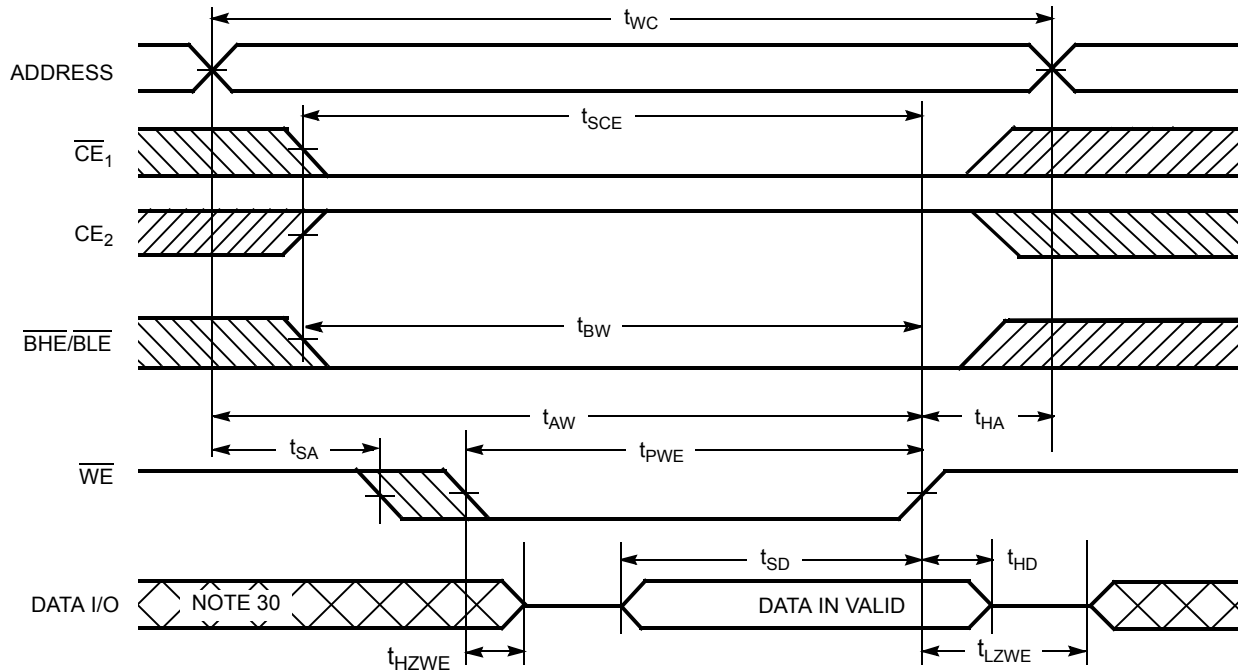
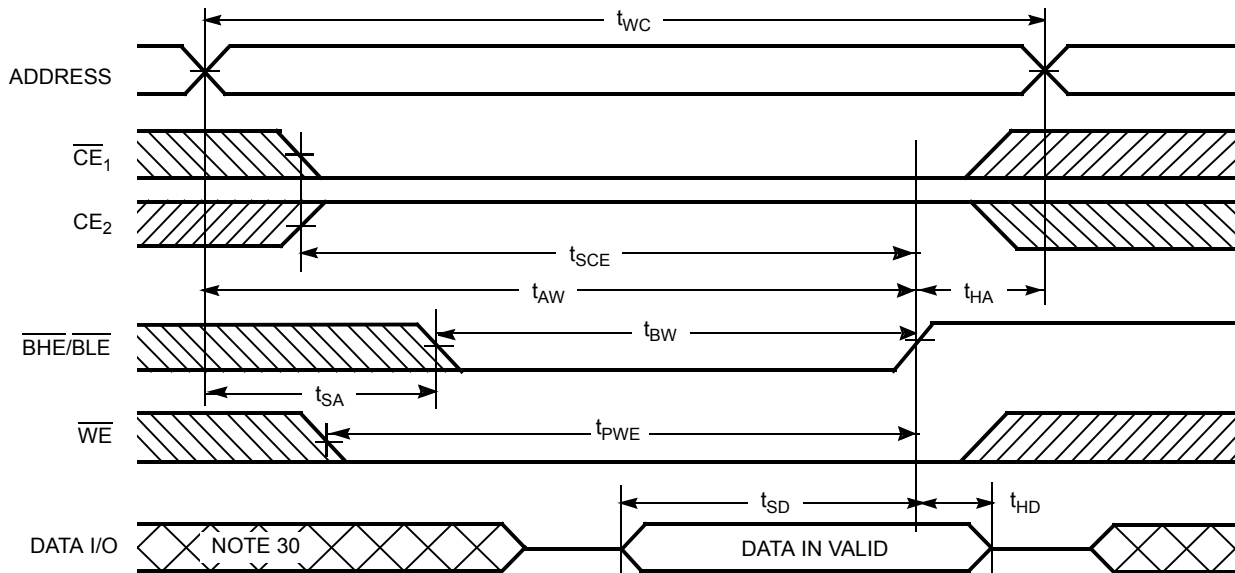
Figure 9. Write Cycle No. 3 (\overline{WE} Controlled, \overline{OE} LOW) [29, 31]Figure 10. Write Cycle No. 4 ($\overline{BHE}/\overline{BLE}$ Controlled, \overline{OE} LOW) [29]**Notes**

29. If \overline{CE}_1 goes HIGH and \overline{CE}_2 goes LOW simultaneously with $\overline{WE} = V_{IH}$, the output remains in a high impedance state.

30. During this period, the I/Os are in output state. Do not apply input signals.

31. The minimum pulse width for write cycle 3 (\overline{WE} controlled, \overline{OE} LOW) should be equal to the sum of t_{SD} and t_{HZWE} .



Truth Table

\overline{CE}_1	\overline{CE}_2	\overline{WE}	\overline{OE}	\overline{BHE}	\overline{BLE}	Inputs/Outputs	Mode	Power
H	X ^[32]	X	X	X ^[32]	X ^[32]	High Z	Deselect/Power-down	Standby (I_{SB})
X ^[32]	L	X	X	X ^[32]	X ^[32]	High Z	Deselect/Power-down	Standby (I_{SB})
X ^[32]	X ^[32]	X	X	H	H	High Z	Deselect/Power-down	Standby (I_{SB})
L	H	H	L	L	L	Data Out (I/O_0 – I/O_{15})	Read	Active (I_{CC})
L	H	H	L	H	L	Data Out (I/O_0 – I/O_7) High Z (I/O_8 – I/O_{15})	Read	Active (I_{CC})
L	H	H	L	L	H	High Z (I/O_0 – I/O_7) Data Out (I/O_8 – I/O_{15})	Read	Active (I_{CC})
L	H	H	H	L	H	High Z	Output disabled	Active (I_{CC})
L	H	H	H	H	L	High Z	Output disabled	Active (I_{CC})
L	H	H	H	L	L	High Z	Output disabled	Active (I_{CC})
L	H	L	X	L	L	Data In (I/O_0 – I/O_{15})	Write	Active (I_{CC})
L	H	L	X	H	L	Data In (I/O_0 – I/O_7) High Z (I/O_8 – I/O_{15})	Write	Active (I_{CC})
L	H	L	X	L	H	High Z (I/O_0 – I/O_7) Data In (I/O_8 – I/O_{15})	Write	Active (I_{CC})

Note

³²The 'X' (Don't care) state for the chip enables and Byte enables in the truth table refer to the logic state (either HIGH or LOW). Intermediate voltage levels on these pins is not permitted.



Ordering Information

Speed (ns)	Ordering Code	Package Diagram	Package Type	Operating Range
55	CY62167ESL-55FNXI	001-96092	WLCSP	Industrial
	CY62167ESL-55FNXIT			

Ordering Code Definitions

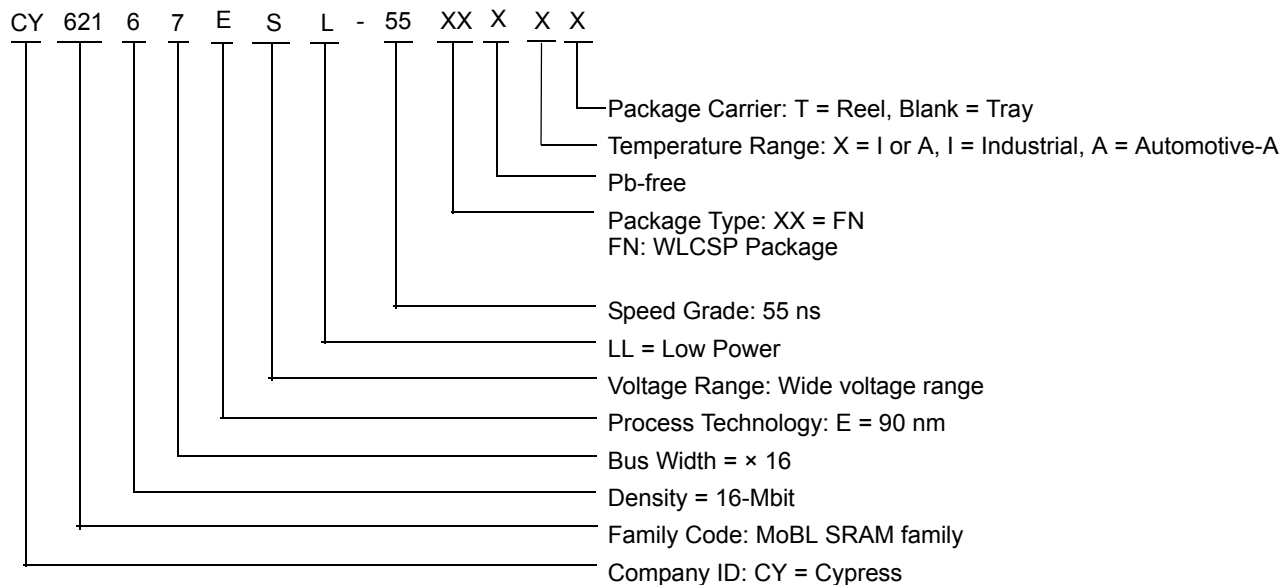

Package Diagram

Figure 11. 60-Pin WLCSP Package Outline

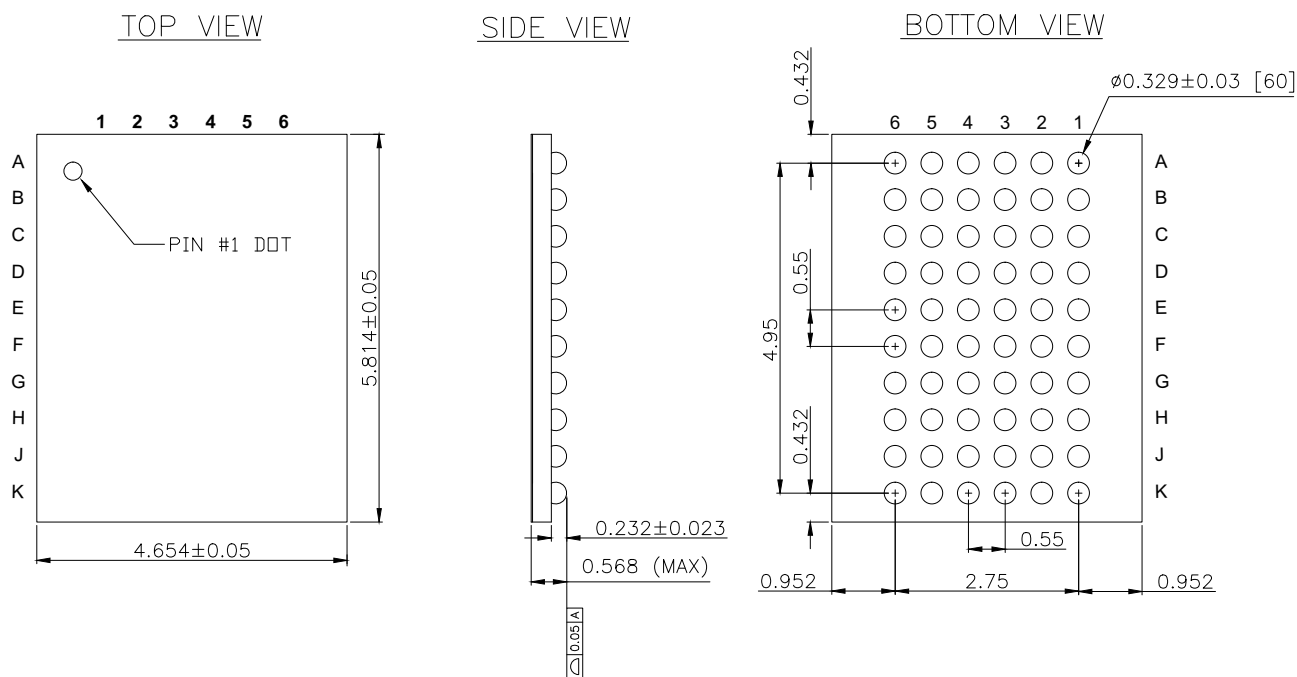

NOTES:

1. Reference Jeduc Publication 95; Design Guide 4.18
2. All dimensions are in millimeters

001-96092 **



Acronyms

Acronym	Description
BHE	byte high enable
BLE	byte low enable
CE	chip enable
CMOS	complementary metal oxide semiconductor
I/O	input/output
OE	output enable
SRAM	static random access memory
TSOP	thin small outline package
VFBGA	very fine-pitch ball grid array
WE	write enable

Document Conventions

Units of Measure

Symbol	Unit of Measure
°C	degree Celsius
MHz	megahertz
μA	microampere
μs	microsecond
mA	milliampere
mm	millimeter
ns	nanosecond
Ω	ohm
%	percent
pF	picofarad
V	volt
W	watt



Document History Page

Document Title: CY62167ESL MoBL [®] , 16-Mbit (1 M × 16) Static RAM Document Number: 001-95928				
Rev.	ECN No.	Orig. of Change	Submission Date	Description of Change
**	4626678	VINI	02/03/2015	New datasheet.
*A	4664021	VINI	02/17/2015	Added Thermal Resistance . Updated the label "V" to "V _{TH} " in Figure 3 .
*B	4841477	VINI	07/16/2015	Updated Ordering Information and Ordering Code Definitions to include Tape and Reel parts.
*C	6003255	AESATMP9	12/22/2017	Updated logo and copyright.



Sales, Solutions, and Legal Information

Worldwide Sales and Design Support

Cypress maintains a worldwide network of offices, solution centers, manufacturer's representatives, and distributors. To find the office closest to you, visit us at [Cypress Locations](#).

Products

Arm [®] Cortex [®] Microcontrollers	cypress.com/arm
Automotive	cypress.com/automotive
Clocks & Buffers	cypress.com/clocks
Interface	cypress.com/interface
Internet of Things	cypress.com/iot
Memory	cypress.com/memory
Microcontrollers	cypress.com/mcu
PSoC	cypress.com/psoc
Power Management ICs	cypress.com/pmic
Touch Sensing	cypress.com/touch
USB Controllers	cypress.com/usb
Wireless Connectivity	cypress.com/wireless

PSoC[®] Solutions

[PSoC 1](#) | [PSoC 3](#) | [PSoC 4](#) | [PSoC 5LP](#) | [PSoC 6 MCU](#)

Cypress Developer Community

[Community](#) | [Projects](#) | [Video](#) | [Blogs](#) | [Training](#) | [Components](#)

Technical Support

cypress.com/support

© Cypress Semiconductor Corporation, 2015-2017. This document is the property of Cypress Semiconductor Corporation and its subsidiaries, including Spansion LLC ("Cypress"). This document, including any software or firmware included or referenced in this document ("Software"), is owned by Cypress under the intellectual property laws and treaties of the United States and other countries worldwide. Cypress reserves all rights under such laws and treaties and does not, except as specifically stated in this paragraph, grant any license under its patents, copyrights, trademarks, or other intellectual property rights. If the Software is not accompanied by a license agreement and you do not otherwise have a written agreement with Cypress governing the use of the Software, then Cypress hereby grants you a personal, non-exclusive, nontransferable license (without the right to sublicense) (1) under its copyright rights in the Software (a) for Software provided in source code form, to modify and reproduce the Software solely for use with Cypress hardware products, only internally within your organization, and (b) to distribute the Software in binary code form externally to end users (either directly or indirectly through resellers and distributors), solely for use on Cypress hardware product units, and (2) under those claims of Cypress's patents that are infringed by the Software (as provided by Cypress, unmodified) to make, use, distribute, and import the Software solely for use with Cypress hardware products. Any other use, reproduction, modification, translation, or compilation of the Software is prohibited.

TO THE EXTENT PERMITTED BY APPLICABLE LAW, CYPRESS MAKES NO WARRANTY OF ANY KIND, EXPRESS OR IMPLIED, WITH REGARD TO THIS DOCUMENT OR ANY SOFTWARE OR ACCOMPANYING HARDWARE, INCLUDING, BUT NOT LIMITED TO, THE IMPLIED WARRANTIES OF MERCHANTABILITY AND FITNESS FOR A PARTICULAR PURPOSE. No computing device can be absolutely secure. Therefore, despite security measures implemented in Cypress hardware or software products, Cypress does not assume any liability arising out of any security breach, such as unauthorized access to or use of a Cypress product. In addition, the products described in these materials may contain design defects or errors known as errata which may cause the product to deviate from published specifications. To the extent permitted by applicable law, Cypress reserves the right to make changes to this document without further notice. Cypress does not assume any liability arising out of the application or use of any product or circuit described in this document. Any information provided in this document, including any sample design information or programming code, is provided only for reference purposes. It is the responsibility of the user of this document to properly design, program, and test the functionality and safety of any application made of this information and any resulting product. Cypress products are not designed, intended, or authorized for use as critical components in systems designed or intended for the operation of weapons, weapons systems, nuclear installations, life-support devices or systems, other medical devices or systems (including resuscitation equipment and surgical implants), pollution control or hazardous substances management, or other uses where the failure of the device or system could cause personal injury, death, or property damage ("Unintended Uses"). A critical component is any component of a device or system whose failure to perform can be reasonably expected to cause the failure of the device or system, or to affect its safety or effectiveness. Cypress is not liable, in whole or in part, and you shall and hereby do release Cypress from any claim, damage, or other liability arising from or related to all Unintended Uses of Cypress products. You shall indemnify and hold Cypress harmless from and against all claims, costs, damages, and other liabilities, including claims for personal injury or death, arising from or related to any Unintended Uses of Cypress products.

Cypress, the Cypress logo, Spansion, the Spansion logo, and combinations thereof, WICED, PSoC, CapSense, EZ-USB, F-RAM, and Traveo are trademarks or registered trademarks of Cypress in the United States and other countries. For a more complete list of Cypress trademarks, visit cypress.com. Other names and brands may be claimed as property of their respective owners.

OUR CERTIFICATE

DiGi provide top-quality products and perfect service for customer worldwide through standardization, technological innovation and continuous improvement. DiGi through third-party certification, we stricly control the quality of products and services. Welcome your RFQ to

Email: Info@DiGi-Electronics.com



Tel: +00 852-30501935

RFQ Email: Info@DiGi-Electronics.com

DiGi is a global authorized distributor of electronic components.