

CY7C1019D-10VXI Datasheet

www.digi-electronics.com

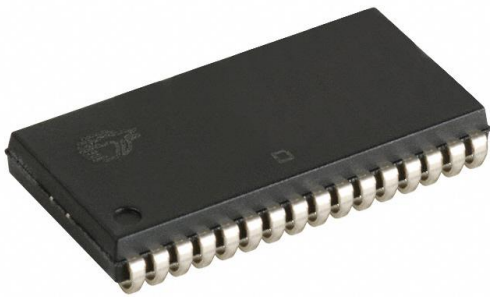

<https://www.DiGi-Electronics.com>

DiGi Electronics Part Number	CY7C1019D-10VXI-DG
Manufacturer	Infineon Technologies
Manufacturer Product Number	CY7C1019D-10VXI
Description	IC SRAM 1MBIT PARALLEL 32SOJ
Detailed Description	SRAM - Asynchronous Memory IC 1Mbit Parallel 10 ns 32-SOJ

This model CY7C1019D-10VXI is available at DiGi.Electronics.

DiGi Electronics offers a global database of semiconductor and electronic component datasheets.

We welcome your inquiries regarding pricing, lead time, or other product-related questions.

 [Request a Quote](#)

 [Datasheet Search](#)



Tel: +00 852-30501935

RFQ Email: Info@DiGi-Electronics.com

DiGi is a global authorized distributor of electronic components.

Purchase and inquiry

Manufacturer Product Number:

CY7C1019D-10VXI

Series:

-

DiGi-Electronics Programmable:

Not Verified

Memory Format:

SRAM

Memory Size:

1Mbit

Memory Interface:

Parallel

Access Time:

10 ns

Operating Temperature:

-40°C ~ 85°C (TA)

Package / Case:

32-BSOJ (0.400", 10.16mm Width)

Base Product Number:

CY7C1019

Manufacturer:

Infineon Technologies

Product Status:

Last Time Buy

Memory Type:

Volatile

Technology:

SRAM - Asynchronous

Memory Organization:

128K x 8

Write Cycle Time - Word, Page:

10ns

Voltage - Supply:

4.5V ~ 5.5V

Mounting Type:

Surface Mount

Supplier Device Package:

32-SOJ

Environmental & Export classification

RoHS Status:

ROHS3 Compliant

REACH Status:

REACH Unaffected

HTSUS:

8542.32.0041

Moisture Sensitivity Level (MSL):

3 (168 Hours)

ECCN:

3A991B2B



Please note that Cypress is an Infineon Technologies Company.

The document following this cover page is marked as “Cypress” document as this is the company that originally developed the product. Please note that Infineon will continue to offer the product to new and existing customers as part of the Infineon product portfolio.

Continuity of document content

The fact that Infineon offers the following product as part of the Infineon product portfolio does not lead to any changes to this document. Future revisions will occur when appropriate, and any changes will be set out on the document history page.

Continuity of ordering part numbers

Infineon continues to support existing part numbers. Please continue to use the ordering part numbers listed in the datasheet for ordering.

**CY7C1019D****1-Mbit (128 K × 8) Static RAM****Features**

- Pin- and function-compatible with CY7C1019B
- High speed
 - $t_{AA} = 10 \text{ ns}$
- Low active power
 - $I_{CC} = 80 \text{ mA @ } 10 \text{ ns}$
- Low CMOS standby power
 - $I_{SB2} = 3 \text{ mA}$
- 2.0 V Data retention
- Automatic power-down when deselected
- CMOS for optimum speed/power
- Center power/ground pinout
- Easy memory expansion with \overline{CE} and \overline{OE} options
- Functionally equivalent to CY7C1019B
- Available in Pb-free 32-pin 400-Mil wide Molded SOJ and 32-pin TSOP II packages

Functional Description

The CY7C1019D ^[1] is a high-performance CMOS static RAM organized as 131,072 words by 8 bits. Easy memory expansion is provided by an active LOW Chip Enable (\overline{CE}), an active LOW Output Enable (\overline{OE}), and tri-state drivers. This device has an automatic power-down feature that significantly reduces power consumption when deselected. The eight input and output pins (IO₀ through IO₇) are placed in a high-impedance state when:

- Deselected (\overline{CE} HIGH)
- Outputs are disabled (\overline{OE} HIGH)
- When the write operation is active (\overline{CE} LOW, and \overline{WE} LOW).

Write to the device by taking Chip Enable (\overline{CE}) and Write Enable (\overline{WE}) inputs LOW. Data on the eight IO pins (IO₀ through IO₇) is then written into the location specified on the address pins (A₀ through A₁₆).

Read from the device by taking Chip Enable (\overline{CE}) and Output Enable (\overline{OE}) LOW while forcing Write Enable (\overline{WE}) HIGH. Under these conditions, the contents of the memory location specified by the address pins appears on the IO pins.

The CY7C1019D device is suitable for interfacing with processors that have TTL I/P levels. It is not suitable for processors that require CMOS I/P levels. Please see [Electrical Characteristics on page 4](#) for more details and suggested alternatives.

For a complete list of related documentation, [click here](#).

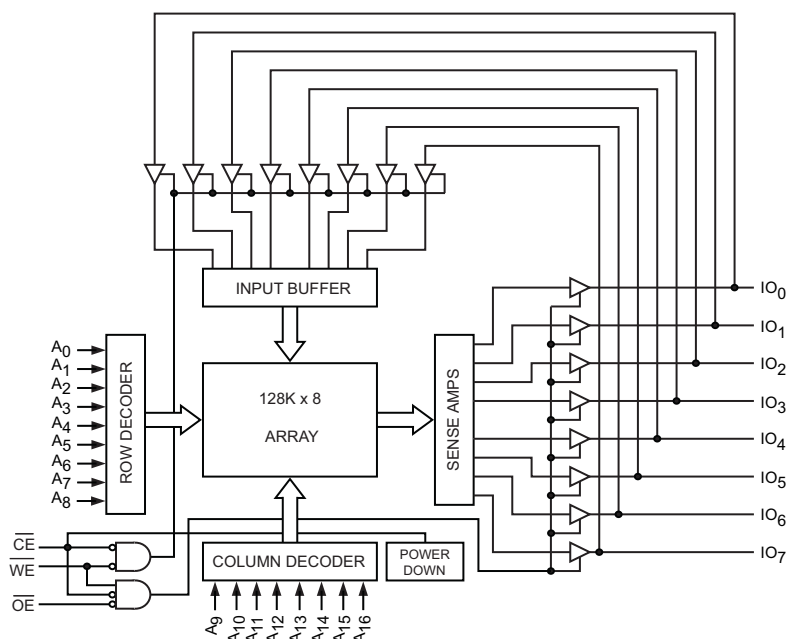
Logic Block Diagram**Note**

1. For guidelines on SRAM system design, please refer to the 'System Design Guidelines' Cypress application note, available on the internet at www.cypress.com.



Contents

Pin Configuration	3	Ordering Information	11
Selection Guide	3	Ordering Code Definitions	11
Maximum Ratings	4	Package Diagrams	12
Operating Range	4	Acronyms	14
Electrical Characteristics	4	Document Conventions	14
Capacitance	5	Units of Measure	14
Thermal Resistance	5	Document History Page	15
AC Test Loads and Waveforms	5	Sales, Solutions, and Legal Information	16
Data Retention Characteristics	6	Worldwide Sales and Design Support	16
Data Retention Waveform	6	Products	16
Switching Characteristics	7	PSoC® Solutions	16
Switching Waveforms	8	Cypress Developer Community	16
Truth Table	11	Technical Support	16



Pin Configuration

Figure 1. 32-pin SOJ / TSOP II pinout (Top View)

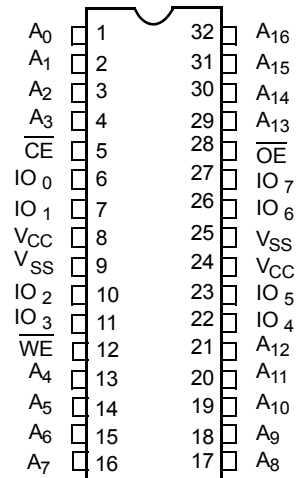

Selection Guide

Description	-10 (Industrial)	Unit
Maximum Access Time	10	ns
Maximum Operating Current	80	mA
Maximum Standby Current	3	mA



Maximum Ratings

Exceeding the maximum ratings may impair the useful life of the device. These user guidelines are not tested.

Storage Temperature	-65 °C to +150 °C
Ambient Temperature with Power Applied	-55 °C to +125 °C
Supply Voltage on V_{CC} to Relative GND ^[2]	-0.5 V to +6.0 V
DC Voltage Applied to Outputs in High Z State ^[2]	-0.5 V to $V_{CC} + 0.5$ V

DC Input Voltage ^[2]	-0.5 V to $V_{CC} + 0.5$ V
Current into Outputs (LOW)	20 mA
Static Discharge Voltage (per MIL-STD-883, Method 3015)	> 2001 V
Latch-up Current	> 200 mA

Operating Range

Range	Ambient Temperature	V_{CC}	Speed
Industrial	-40 °C to +85 °C	5 V ± 0.5 V	10 ns

Electrical Characteristics

Over the Operating Range

Parameter	Description	Test Conditions	-10 (Industrial)		Unit	
			Min	Max		
V_{OH}	Output HIGH Voltage	$I_{OH} = -4.0$ mA	2.4	-	V	
		$I_{OH} = -0.1$ mA	-	3.4 ^[3]		
V_{OL}	Output LOW Voltage	$I_{OL} = 8.0$ mA	-	0.4	V	
V_{IH}	Input HIGH Voltage		2.2	$V_{CC} + 0.5$	V	
V_{IL}	Input LOW Voltage ^[2]		-0.5	0.8	V	
I_{IX}	Input Leakage Current	$GND \leq V_I \leq V_{CC}$	-1	+1	μ A	
I_{OZ}	Output Leakage Current	$GND \leq V_I \leq V_{CC}$, Output Disabled	-1	+1	μ A	
I_{CC}	V_{CC} Operating Supply Current	$V_{CC} = \text{Max}$, $I_{OUT} = 0$ mA, $f = f_{max} = 1/t_{RC}$	100 MHz	-	80	mA
			83 MHz	-	72	
			66 MHz	-	58	
			40 MHz	-	37	
I_{SB1}	Automatic CE Power-Down Current – TTL Inputs	$\text{Max } V_{CC}$, $\overline{CE} \geq V_{IH}$, $V_{IN} \geq V_{IH}$ or $V_{IN} \leq V_{IL}$, $f = f_{max}$	-	10	mA	
I_{SB2}	Automatic CE Power-Down Current – CMOS Inputs	$\text{Max } V_{CC}$, $\overline{CE} \geq V_{CC} - 0.3$ V, $V_{IN} \geq V_{CC} - 0.3$ V, or $V_{IN} \leq 0.3$ V, $f = 0$	-	3	mA	

Note

- V_{IL} (min) = -2.0 V and V_{IH} (max) = $V_{CC} + 1$ V for pulse durations of less than 5 ns.
- Please note that the maximum V_{OH} limit does not exceed minimum CMOS V_{IH} of 3.5V. If you are interfacing this SRAM with 5 V legacy processors that require a minimum V_{IH} of 3.5 V, please refer to Application Note [AN6081](#) for technical details and options you may consider.

Capacitance

Parameter ^[4]	Description	Test Conditions	Max	Unit
C_{IN}	Input capacitance	$T_A = 25\text{ }^\circ\text{C}$, $f = 1\text{ MHz}$, $V_{CC} = 5.0\text{ V}$	6	pF
C_{OUT}	Output capacitance		8	pF

Thermal Resistance

Parameter ^[4]	Description	Test Conditions	400-Mil Wide SOJ	TSOP II	Unit
Θ_{JA}	Thermal resistance (junction to ambient)	Still Air, soldered on a 3×4.5 inch, four-layer printed circuit board	56.29	62.22	$^\circ\text{C/W}$
Θ_{JC}	Thermal resistance (junction to case)		38.14	21.43	$^\circ\text{C/W}$

AC Test Loads and Waveforms

Figure 2. AC Test Loads and Waveforms ^[5]

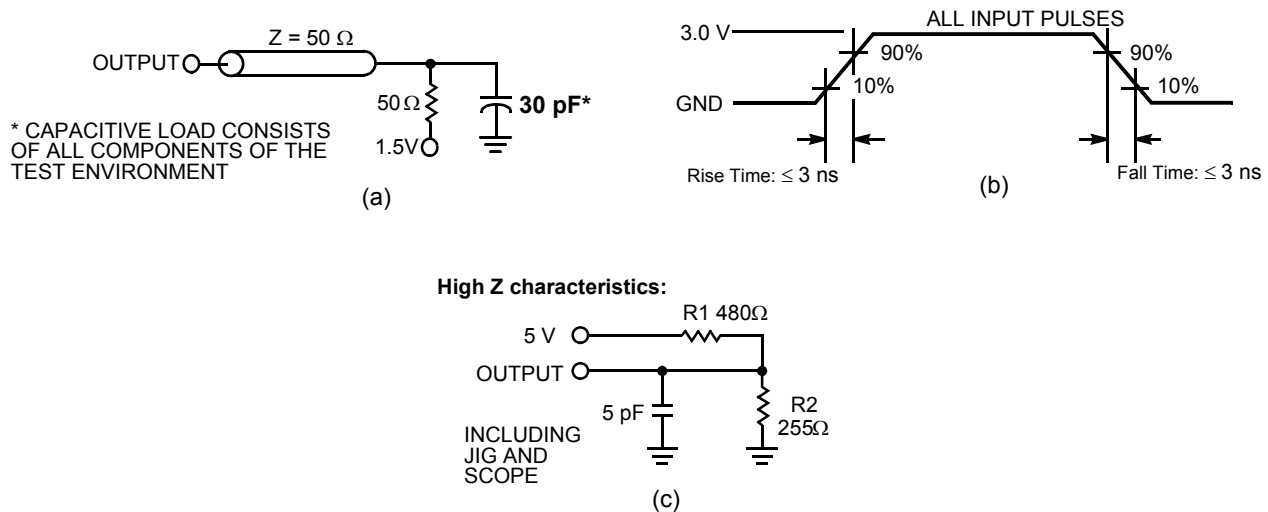

Notes

- Tested initially and after any design or process changes that may affect these parameters.
- AC characteristics (except High Z) are tested using the load conditions shown in Figure 2 (a). High Z characteristics are tested for all speeds using the test load shown in Figure 2 (c).

Data Retention Characteristics

Over the Operating Range

Parameter	Description	Conditions	Min	Max	Unit
V_{DR}	V_{CC} for Data Retention		2.0	–	V
I_{CCDR}	Data Retention Current	$V_{CC} = V_{DR} = 2.0\text{ V}$, $\overline{CE} \geq V_{CC} - 0.3\text{ V}$, $V_{IN} \geq V_{CC} - 0.3\text{ V}$ or $V_{IN} \leq 0.3\text{ V}$	–	3	mA
$t_{CDR}^{[6]}$	Chip Deselect to Data Retention Time		0	–	ns
$t_R^{[7]}$	Operation Recovery Time		t_{RC}	–	ns

Data Retention Waveform

Figure 3. Data Retention Waveform

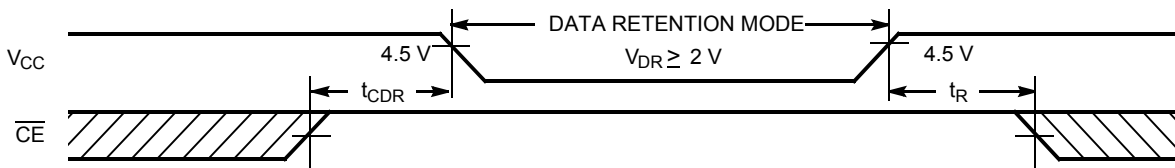

Notes

- Tested initially and after any design or process changes that may affect these parameters.
- Full device operation requires linear V_{CC} ramp from V_{DR} to $V_{CC(min)} \geq 50\ \mu\text{s}$ or stable at $V_{CC(min)} \geq 50\ \mu\text{s}$.



Switching Characteristics

Over the Operating Range

Parameter ^[8]	Description	-10 (Industrial)		Unit
		Min	Max	
Read Cycle				
$t_{\text{power}}^{[9]}$	V_{CC} (typical) to the first access	100	–	μs
t_{RC}	Read Cycle Time	10	–	ns
t_{AA}	Address to Data Valid	–	10	ns
t_{OHA}	Data Hold from Address Change	3	–	ns
t_{ACE}	$\overline{\text{CE}}$ LOW to Data Valid	–	10	ns
t_{DOE}	$\overline{\text{OE}}$ LOW to Data Valid	–	5	ns
t_{LZOE}	$\overline{\text{OE}}$ LOW to Low Z	0	–	ns
t_{HZOE}	$\overline{\text{OE}}$ HIGH to High Z ^[10, 11]	–	5	ns
t_{LZCE}	$\overline{\text{CE}}$ LOW to Low Z ^[11]	3	–	ns
t_{HZCE}	$\overline{\text{CE}}$ HIGH to High Z ^[10, 11]	–	5	ns
$t_{\text{PU}}^{[12]}$	$\overline{\text{CE}}$ LOW to Power-Up	0	–	ns
$t_{\text{PD}}^{[12]}$	$\overline{\text{CE}}$ HIGH to Power-Down	–	10	ns
Write Cycle ^[13, 14]				
t_{WC}	Write Cycle Time	10	–	ns
t_{SCE}	$\overline{\text{CE}}$ LOW to Write End	7	–	ns
t_{AW}	Address Set-Up to Write End	7	–	ns
t_{HA}	Address Hold from Write End	0	–	ns
t_{SA}	Address Set-Up to Write Start	0	–	ns
t_{PWE}	$\overline{\text{WE}}$ Pulse Width	7	–	ns
t_{SD}	Data Set-Up to Write End	6	–	ns
t_{HD}	Data Hold from Write End	0	–	ns
t_{LZWE}	$\overline{\text{WE}}$ HIGH to Low Z ^[11]	3	–	ns
t_{HZWE}	$\overline{\text{WE}}$ LOW to High Z ^[10, 11]	–	5	ns

Notes

- Test conditions assume signal transition time of 3 ns or less, timing reference levels of 1.5 V, input pulse levels of 0 to 3.0 V, and output loading of the specified $I_{\text{OL}}/I_{\text{OH}}$ and 30-pF load capacitance.
- t_{POWER} gives the minimum amount of time that the power supply should be at typical V_{CC} values until the first memory access can be performed.
- t_{HZOE} , t_{HZCE} , and t_{HZWE} are specified with a load capacitance of 5 pF as in (c) of [Figure 2 on page 5](#). Transition is measured when the outputs enter a high impedance state.
- At any given temperature and voltage condition, t_{HZCE} is less than t_{LZCE} , t_{HZOE} is less than t_{LZOE} , and t_{HZWE} is less than t_{LZWE} for any given device.
- This parameter is guaranteed by design and is not tested.
- The internal write time of the memory is defined by the overlap of $\overline{\text{CE}}$ LOW and $\overline{\text{WE}}$ LOW. $\overline{\text{CE}}$ and $\overline{\text{WE}}$ must be LOW to initiate a write, and the transition of any of these signals can terminate the write. The input data set-up and hold timing should be referenced to the leading edge of the signal that terminates the write.
- The minimum write cycle time for Write Cycle no. 3 ($\overline{\text{WE}}$ controlled, $\overline{\text{OE}}$ LOW) is the sum of t_{HZWE} and t_{SD} .

Switching Waveforms

Figure 4. Read Cycle No. 1 (Address Transition Controlled) [15, 16]

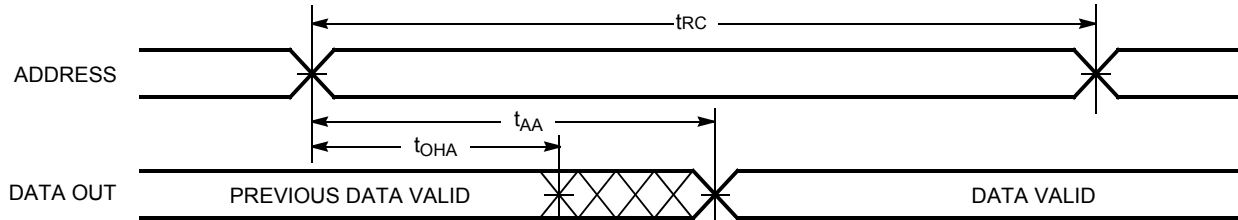
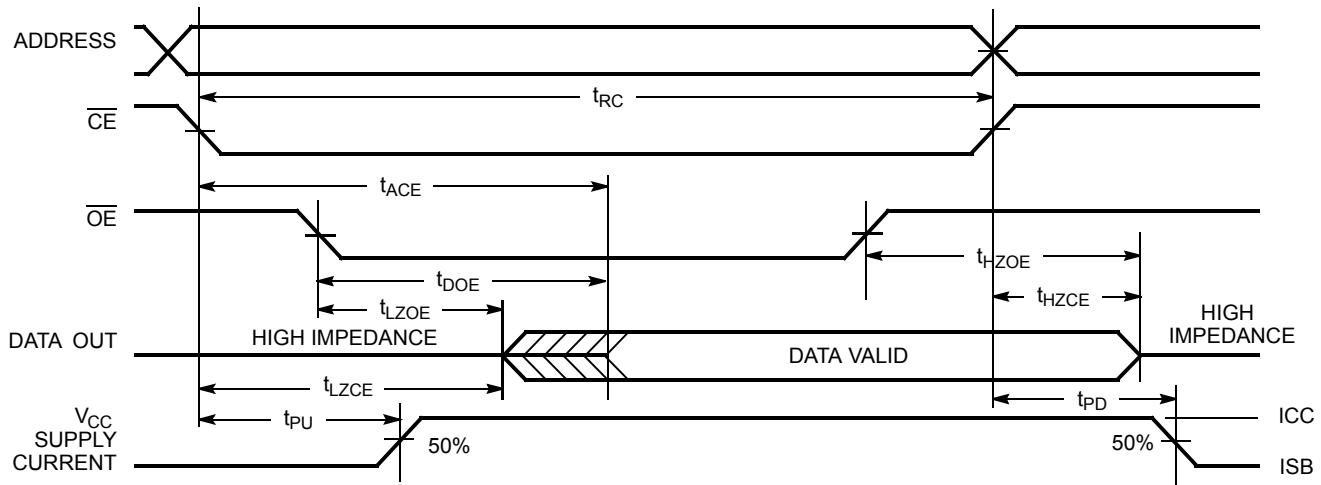

Figure 5. Read Cycle No. 2 (\overline{OE} Controlled) [16, 17]



Notes

15. Device is continuously selected. \overline{OE} , $\overline{CE} = V_{IL}$.
16. \overline{WE} is HIGH for Read cycle.
17. Address valid prior to or coincident with \overline{CE} transition LOW.

Switching Waveforms (continued)

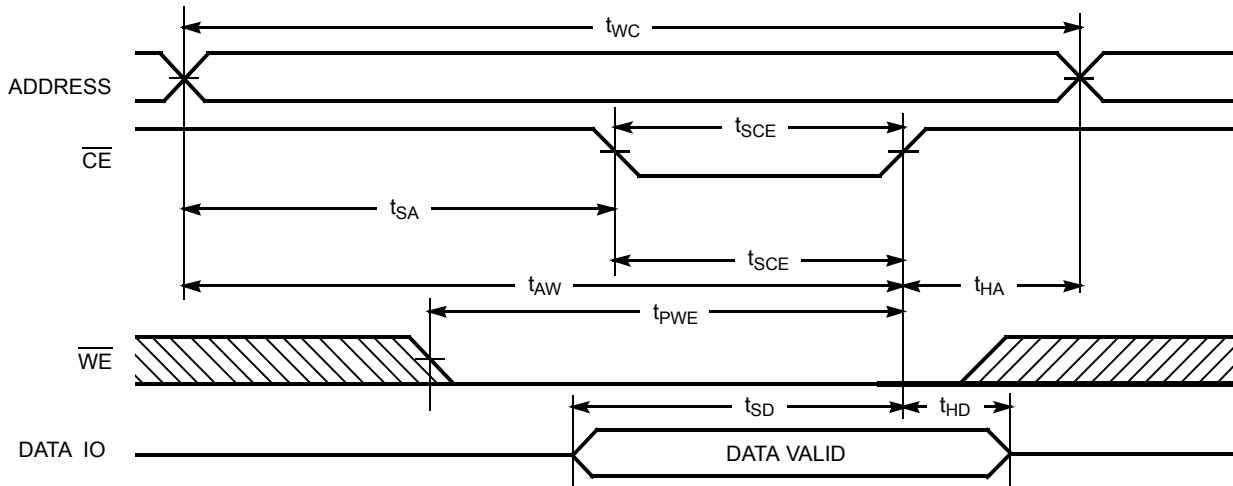
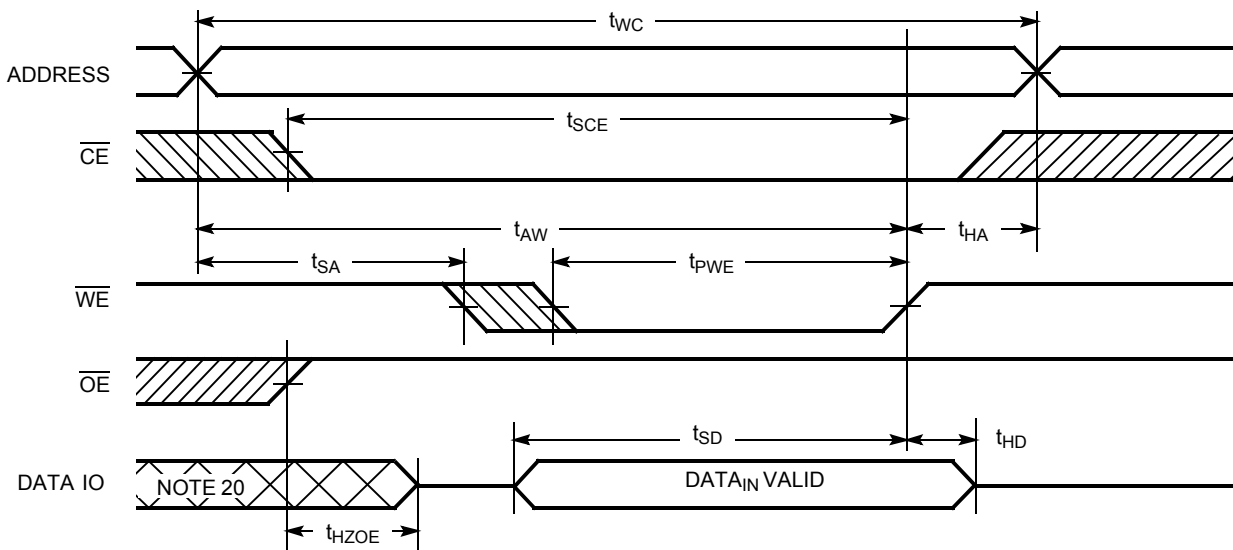
Figure 6. Write Cycle No. 1 ($\overline{\text{CE}}$ Controlled) [18, 19]Figure 7. Write Cycle No. 2 ($\overline{\text{WE}}$ Controlled, $\overline{\text{OE}}$ HIGH During Write) [18, 19]

Notes

18. Data IO is high impedance if $\overline{\text{OE}} = V_{\text{IH}}$.
19. If CE goes HIGH simultaneously with WE going HIGH, the output remains in a high-impedance state.
20. During this period the IOs are in the output state and input signals should not be applied.

Switching Waveforms (continued)

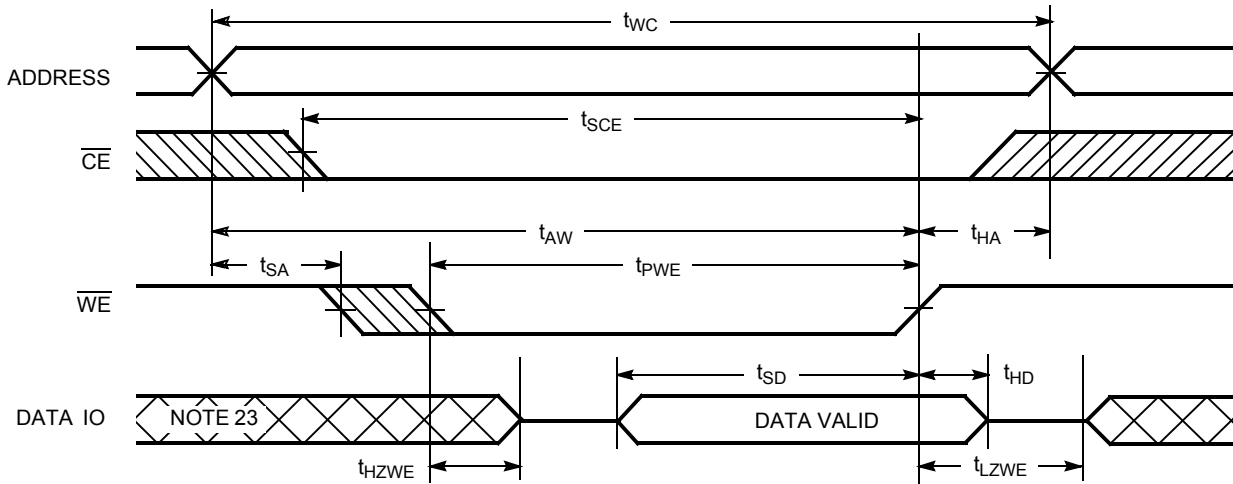
Figure 8. Write Cycle No. 3 (\overline{WE} Controlled, \overline{OE} LOW) [21, 22]

Notes

21. The minimum write cycle time for Write Cycle no. 3 (\overline{WE} Controlled, \overline{OE} LOW) is the sum of t_{HZWE} and t_{SD} .

22. If \overline{CE} goes HIGH simultaneously with \overline{WE} going HIGH, the output remains in a high-impedance state.

23. During this period the IOs are in the output state and input signals should not be applied.



Truth Table

\overline{CE}	\overline{OE}	\overline{WE}	IO_0 - IO_7	Mode	Power
H	X	X	High Z	Power-Down	Standby (I_{SB})
L	L	H	Data Out	Read	Active (I_{CC})
L	X	L	Data In	Write	Active (I_{CC})
L	H	H	High Z	Selected, Outputs Disabled	Active (I_{CC})

Ordering Information

Speed (ns)	Ordering Code	Package Diagram	Package Type	Operating Range
10	CY7C1019D-10VXI	51-85033	32-pin SOJ (400 Mils) Pb-free	Industrial
	CY7C1019D-10ZSXI	51-85095	32-pin TSOP (Type II) Pb-free	

Please contact your local Cypress sales representative for availability of these parts.

Ordering Code Definitions

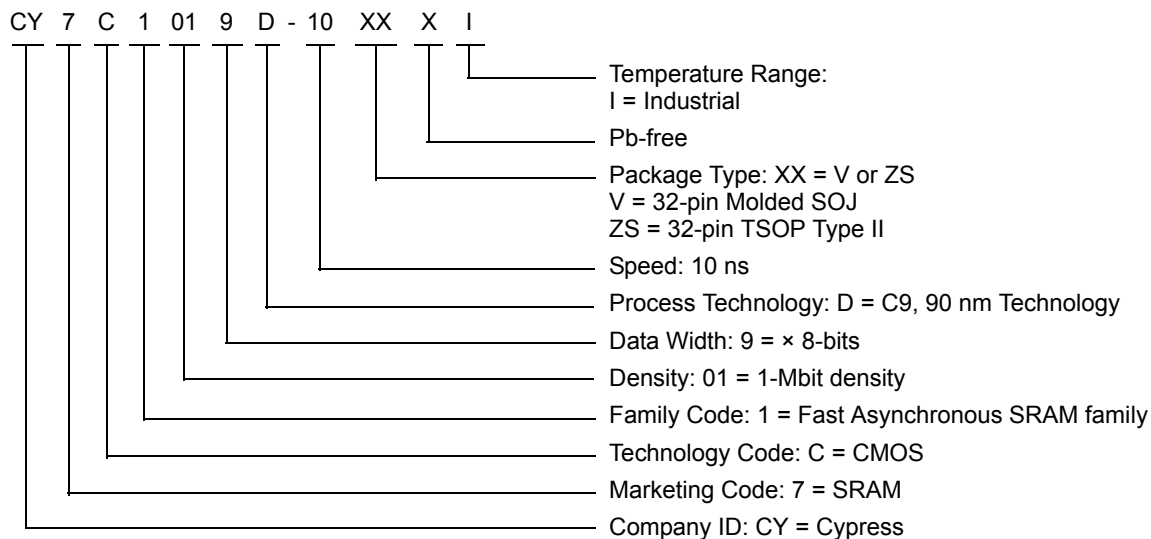



Package Diagrams

Figure 9. 32-pin SOJ (400 Mils) V32.4 (Molded SOJ V33) Package Outline, 51-85033

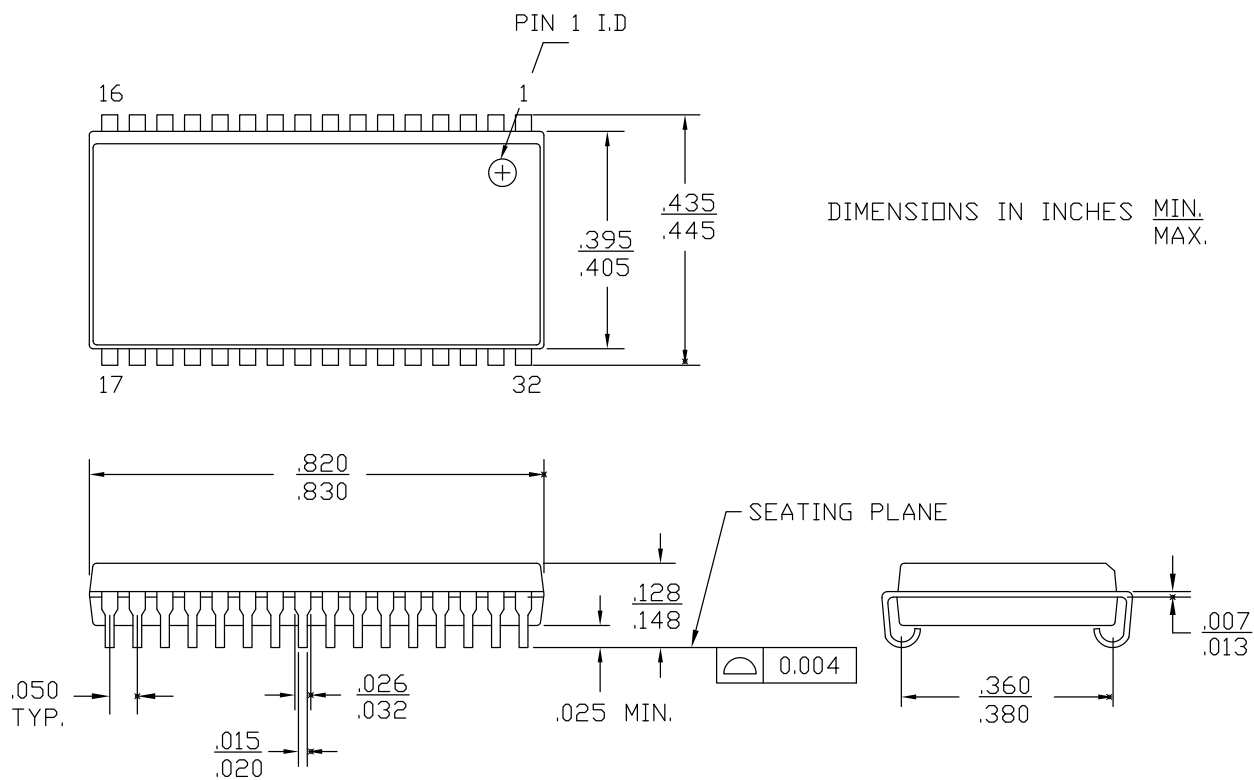

51-85033 *E

Package Diagrams (continued)

Figure 10. 32-pin TSOP II (20.95 × 11.76 × 1.0 mm) ZS32 Package Outline, 51-85095

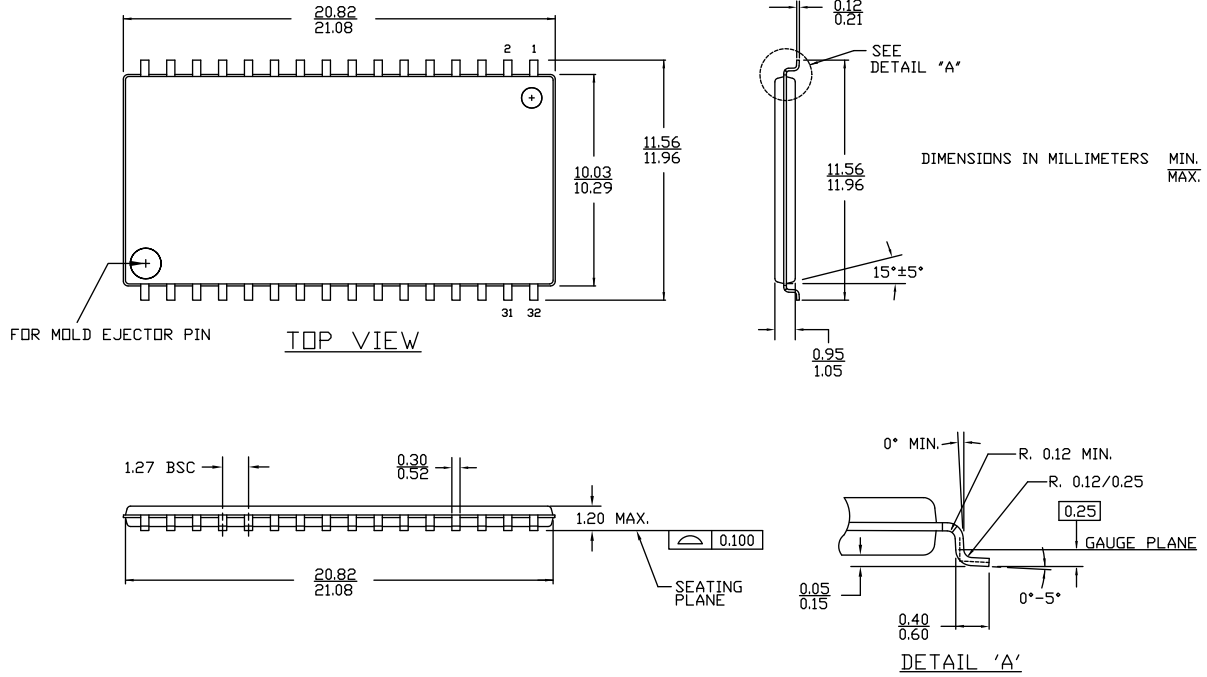

51-85095 *D



Acronyms

Acronym	Description
\overline{CE}	Chip Enable
CMOS	Complementary Metal Oxide Semiconductor
I/O	Input/Output
\overline{OE}	Output Enable
SOJ	Small Outline J-lead
SRAM	Static Random Access Memory
TSOP	Thin Small Outline Package
TTL	Transistor-Transistor Logic
\overline{WE}	Write Enable

Document Conventions

Units of Measure

Symbol	Unit of Measure
$^{\circ}\text{C}$	degree Celsius
MHz	megahertz
μA	microampere
μs	microsecond
mA	milliampere
ms	millisecond
mm	millimeter
ns	nanosecond
Ω	ohm
%	percent
pF	picofarad
V	volt
W	watt



Document History Page

Document Title: CY7C1019D, 1-Mbit (128 K × 8) Static RAM Document Number: 38-05464				
Rev.	ECN No.	Issue Date	Orig. of Change	Description of Change
**	201560	See ECN	SWI	Advance Information data sheet for C9 IPP
*A	233715	See ECN	RKF	DC parameters are modified as per EROS (Spec # 01-2165) Pb-free offering in the Ordering Information
*B	262950	See ECN	RKF	Added T _{power} Spec in Switching Characteristics table Added Data Retention Characteristics table and waveforms Shaded Ordering Information
*C	307598	See ECN	RKF	Reduced Speed bins to -10 and -12 ns
*D	520647	See ECN	VKN	Changed status from Preliminary to Final. Removed Commercial Temperature Range related information in all instances across the document. Removed 12 ns speed bin related information in all instances across the document. Updated Electrical Characteristics : Added values of I _{CC} parameter corresponding to Test Conditions 83 MHz, 66 MHz and 40 MHz. Updated Note 2 (Replaced "V _{CC} + 2 V" with "V _{CC} + 1 V"). Updated Thermal Resistance . Updated Ordering Information .
*E	802877	See ECN	VKN	Updated Electrical Characteristics : Changed maximum value of I _{CC} parameter from 60 mA to 80 mA corresponding to Test Condition 100 MHz. Changed maximum value of I _{CC} parameter from 55 mA to 72 mA corresponding to Test Condition 83 MHz. Changed maximum value of I _{CC} parameter from 45 mA to 58 mA corresponding to Test Condition 66 MHz. Changed maximum value of I _{CC} parameter from 30 mA to 37 mA corresponding to Test Condition 40 MHz.
*F	3110052	12/14/2010	AJU	Added Ordering Code Definitions . Updated Package Diagrams .
*G	3245896	05/02/2011	PRAS	Updated Package Diagrams . Added Acronyms and Units of Measure . Updated to new template.
*H	4038234	06/24/2013	MEMJ	Updated Functional Description . Updated Electrical Characteristics : Added one more Test Condition "I _{OH} = -0.1 mA" for V _{OH} parameter and added maximum value corresponding to that Test Condition. Added Note 3 and referred the same note in maximum value for V _{OH} parameter corresponding to Test Condition "I _{OH} = -0.1 mA". Updated to new template.
*I	4385827	05/21/2014	MEMJ	Updated Package Diagrams : spec 51-85033 – Changed revision from *D to *E. Completing Sunset Review.
*J	4579569	11/26/2014	MEMJ	Updated Functional Description : Added "For a complete list of related documentation, click here ." at the end.
*K	4795495	06/12/2015	NILE	Updated Package Diagrams : spec 51-85095 – Changed revision from *B to *D. Updated to new template.



Sales, Solutions, and Legal Information

Worldwide Sales and Design Support

Cypress maintains a worldwide network of offices, solution centers, manufacturer's representatives, and distributors. To find the office closest to you, visit us at [Cypress Locations](#).

Products

Automotive	cypress.com/go/automotive
Clocks & Buffers	cypress.com/go/clocks
Interface	cypress.com/go/interface
Lighting & Power Control	cypress.com/go/powerpsoc
Memory	cypress.com/go/memory
PSoC	cypress.com/go/psoc
Touch Sensing	cypress.com/go/touch
USB Controllers	cypress.com/go/USB
Wireless/RF	cypress.com/go/wireless

PSoC[®] Solutions

psoc.cypress.com/solutions
 PSoC 1 | PSoC 3 | PSoC 4 | PSoC 5LP

Cypress Developer Community

[Community](#) | [Forums](#) | [Blogs](#) | [Video](#) | [Training](#)

Technical Support

cypress.com/go/support

© Cypress Semiconductor Corporation, 2004-2015. The information contained herein is subject to change without notice. Cypress Semiconductor Corporation assumes no responsibility for the use of any circuitry other than circuitry embodied in a Cypress product. Nor does it convey or imply any license under patent or other rights. Cypress products are not warranted nor intended to be used for medical, life support, life saving, critical control or safety applications, unless pursuant to an express written agreement with Cypress. Furthermore, Cypress does not authorize its products for use as critical components in life-support systems where a malfunction or failure may reasonably be expected to result in significant injury to the user. The inclusion of Cypress products in life-support systems application implies that the manufacturer assumes all risk of such use and in doing so indemnifies Cypress against all charges.

Any Source Code (software and/or firmware) is owned by Cypress Semiconductor Corporation (Cypress) and is protected by and subject to worldwide patent protection (United States and foreign), United States copyright laws and international treaty provisions. Cypress hereby grants to licensee a personal, non-exclusive, non-transferable license to copy, use, modify, create derivative works of, and compile the Cypress Source Code and derivative works for the sole purpose of creating custom software and or firmware in support of licensee product to be used only in conjunction with a Cypress integrated circuit as specified in the applicable agreement. Any reproduction, modification, translation, compilation, or representation of this Source Code except as specified above is prohibited without the express written permission of Cypress.

Disclaimer: CYPRESS MAKES NO WARRANTY OF ANY KIND, EXPRESS OR IMPLIED, WITH REGARD TO THIS MATERIAL, INCLUDING, BUT NOT LIMITED TO, THE IMPLIED WARRANTIES OF MERCHANTABILITY AND FITNESS FOR A PARTICULAR PURPOSE. Cypress reserves the right to make changes without further notice to the materials described herein. Cypress does not assume any liability arising out of the application or use of any product or circuit described herein. Cypress does not authorize its products for use as critical components in life-support systems where a malfunction or failure may reasonably be expected to result in significant injury to the user. The inclusion of Cypress' product in a life-support systems application implies that the manufacturer assumes all risk of such use and in doing so indemnifies Cypress against all charges.

Use may be limited by and subject to the applicable Cypress software license agreement.

OUR CERTIFICATE

DiGi provide top-quality products and perfect service for customer worldwide through standardization, technological innovation and continuous improvement. DiGi through third-party certification, we strictly control the quality of products and services. Welcome your RFQ to

Email: Info@DiGi-Electronics.com



Tel: +00 852-30501935

RFQ Email: Info@DiGi-Electronics.com

DiGi is a global authorized distributor of electronic components.