

CY7C1021BN-12ZXC Datasheet

www.digi-electronics.com

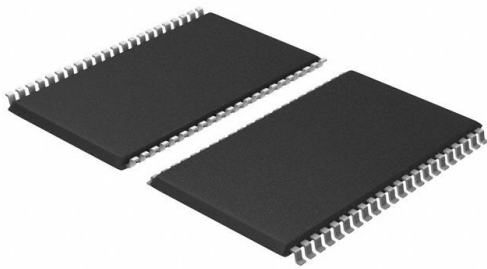

<https://www.DiGi-Electronics.com>

DiGi Electronics Part Number	CY7C1021BN-12ZXC-DG
Manufacturer	Infineon Technologies
Manufacturer Product Number	CY7C1021BN-12ZXC
Description	IC SRAM 1MBIT PARALLEL 44TSOP II
Detailed Description	SRAM - Asynchronous Memory IC 1Mbit Parallel 12 ns 44-TSOP II

This model CY7C1021BN-12ZXC is available at DiGi Electronics.

DiGi Electronics offers a global database of semiconductor and electronic component datasheets.

We welcome your inquiries regarding pricing, lead time, or other product-related questions.

 [Request a Quote](#)

 [Datasheet Search](#)



Tel: +00 852-30501935

RFQ Email: Info@DiGi-Electronics.com

DiGi is a global authorized distributor of electronic components.

Purchase and inquiry

Manufacturer Product Number:

CY7C1021BN-12ZX

Series:

-

DiGi-Electronics Programmable:

Not Verified

Memory Format:

SRAM

Memory Size:

1Mbit

Memory Interface:

Parallel

Access Time:

12 ns

Operating Temperature:

0°C ~ 70°C (TA)

Package / Case:

44-TSOP (0.400", 10.16mm Width)

Base Product Number:

CY7C1021

Manufacturer:

Infineon Technologies

Product Status:

Obsolete

Memory Type:

Volatile

Technology:

SRAM - Asynchronous

Memory Organization:

64K x 16

Write Cycle Time - Word, Page:

12ns

Voltage - Supply:

4.5V ~ 5.5V

Mounting Type:

Surface Mount

Supplier Device Package:

44-TSOP II

Environmental & Export classification

RoHS Status:

ROHS3 Compliant

REACH Status:

REACH Unaffected

HTSUS:

8542.32.0041

Moisture Sensitivity Level (MSL):

3 (168 Hours)

ECCN:

3A991B2B



CY7C1021BN

1-Mbit (64 K × 16) Static RAM

Features

- Temperature ranges
 - Commercial: 0 °C to 70 °C
 - Industrial: -40 °C to 85 °C
 - Automotive-A: -40 °C to 85 °C
 - Automotive-E: -40 °C to 125 °C
- High speed
 - t_{AA} = 15 ns (Automotive)
- Complementary metal oxide semiconductor (CMOS) for optimum speed/power
- Low active power
 - 825 mW (maximum)
- Automatic power down when deselected
- Independent control of upper and lower bits
- Available in Pb-free and non Pb-free 44-pin TSOP II and 44-pin 400-mil-wide SOJ

Functional Description

The CY7C1021BN is a high performance CMOS static RAM organized as 65,536 words by 16 bits. This device has an automatic power down feature that significantly reduces power consumption when deselected.

Writing to the device is accomplished by taking Chip Enable (\overline{CE}) and Write Enable (WE) inputs LOW. If Byte Low Enable (BLE) is LOW, then data from the input/output (I/O) pins (I/O₁ through I/O₈), is written into the location specified on the address pins (A₀ through A₁₅). If Byte High Enable (BHE) is LOW, then data from I/O pins (I/O₉ through I/O₁₆) is written into the location specified on the address pins (A₀ through A₁₅).

Reading from the device is accomplished by taking \overline{CE} and Output Enable (OE) LOW while forcing WE HIGH. If BLE is LOW, then data from the memory location specified by the address pins appears on I/O₁ to I/O₈. If BHE is LOW, then data from memory appears on I/O₉ to I/O₁₆. See the Truth Table on page 11 for a complete description of read and write modes.

The I/O pins (I/O₁ through I/O₁₆) are placed in a high impedance state when the device is deselected (\overline{CE} HIGH), the outputs are disabled (OE HIGH), the BHE and BLE are disabled (BHE, BLE HIGH), or during a write operation (\overline{CE} LOW, WE LOW).

The CY7C1021BN is available in standard 44-pin TSOP type II and 44-pin 400-mil-wide SOJ packages. Use part number CY7C1021BN when ordering 15 ns t_{AA} .

For a complete list of related resources, click [here](#).

Logic Block Diagram

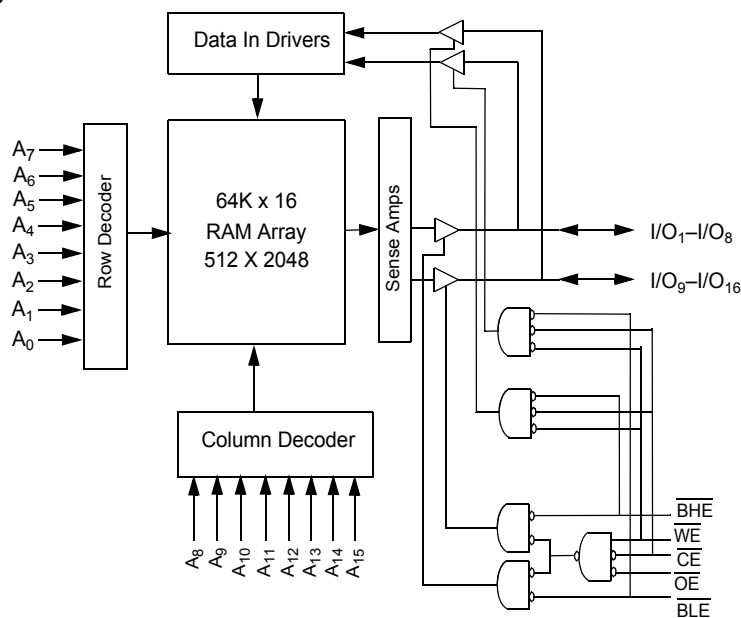



Contents

Selection Guide	3	Package Diagrams	13
Pin Configuration	3	Acronyms	14
Pin Definitions	4	Document Conventions	14
Maximum Ratings	5	Units of Measure	14
Operating Range	5	Document History Page	15
Electrical Characteristics	5	Sales, Solutions, and Legal Information	16
Capacitance	6	Worldwide Sales and Design Support	16
Thermal Resistance	6	Products	16
AC Test Loads and Waveforms	6	PSoC® Solutions	16
Switching Characteristics	7	Cypress Developer Community	16
Switching Waveforms	8	Technical Support	16
Truth Table	11		
Ordering Information	12		
Ordering Code Definitions	12		

Selection Guide

Description		CY7C1021B-15
Maximum access time (ns)		15
Maximum operating current (mA)	Commercial/Industrial	130
	Automotive-A	130
	Automotive-E	130
Maximum CMOS standby current (mA)	Commercial/Industrial	10
	Commercial/Industrial (L version)	0.5
	Automotive-A (L version)	0.5
	Automotive-E	15

Pin Configuration

Figure 1. 44-pin SOJ/TSOP II pinout (Top View)

A ₄	1	44	A ₅
A ₃	2	43	A ₆
A ₂	3	42	A ₇
A ₁	4	41	OE
A ₀	5	40	BHE
CE	6	39	BLE
I/O ₁	7	38	I/O ₁₆
I/O ₂	8	37	I/O ₁₅
I/O ₃	9	36	I/O ₁₄
I/O ₄	10	35	I/O ₁₃
V _{CC}	11	34	V _{SS}
V _{SS}	12	33	V _{CC}
I/O ₅	13	32	I/O ₁₂
I/O ₆	14	31	I/O ₁₁
I/O ₇	15	30	I/O ₁₀
I/O ₈	16	29	I/O ₉
WE	17	28	NC
A ₁₅	18	27	A ₈
A ₁₄	19	26	A ₉
A ₁₃	20	25	A ₁₀
A ₁₂	21	24	A ₁₁
NC	22	23	NC



Pin Definitions

Pin Name	Pin Number	I/O Type	Description
A ₀ -A ₁₅	1-5, 18-21, 24-27, 42-44	Input	Address inputs used to select one of the address locations.
I/O ₁ -I/O ₁₆	7-10, 13-16, 29-32, 35-38	Input/Output	Bidirectional data I/O lines. Used as input or output lines depending on operation.
NC	22, 23, 28	No Connect	Not connected to the die.
\overline{WE}	17	Input/Control	Write enable input, active LOW. When selected LOW, a write is conducted. When deselected HIGH, a read is conducted.
\overline{CE}	6	Input/Control	Chip enable input, active LOW. When LOW, selects the chip. When HIGH, deselects the chip.
\overline{BHE} , \overline{BLE}	40, 39	Input/Control	Byte enable select inputs, active LOW. \overline{BHE} controls I/O ₁₆ -I/O ₉ , \overline{BLE} controls I/O ₈ -I/O ₁ .
\overline{OE}	41	Input/Control	Output enable, active LOW. Controls the direction of the I/O pins. When LOW, the I/O pins are allowed to behave as outputs. When deasserted HIGH, I/O pins are tristated, and act as input data pins.
V _{SS}	12, 34	Ground	Ground for the device. Should be connected to ground of the system.
V _{CC}	11, 33	Power Supply	Power supply inputs to the device.



Maximum Ratings

Exceeding the maximum ratings may impair the useful life of the device. These user guidelines are not tested.

Storage temperature -65 °C to +150 °C

Ambient temperature with power applied -55 °C to +125 °C

Supply voltage on V_{CC} relative to GND ^[1] -0.5 V to +7.0 V

DC voltage applied to outputs in High Z state ^[1] -0.5 V to $V_{CC} + 0.5$ V

DC input voltage ^[1] -0.5 V to $V_{CC} + 0.5$ V

Current into outputs (LOW) 20 mA

Static discharge voltage (per MIL-STD-883, Method 3015) > 2001 V

Latch-up current > 200 mA

Operating Range

Range	Ambient Temperature (T_A) ^[2]	V_{CC}
Commercial	0 °C to +70 °C	5 V ± 10%
Industrial	-40 °C to +85 °C	
Automotive-A	-40 °C to +85 °C	
Automotive-E	-40 °C to +125 °C	

Electrical Characteristics

Over the operating range

Parameter	Description	Test Conditions	-15		Unit	
			Min	Max		
V_{OH}	Output HIGH voltage	$V_{CC} = \text{Min}, I_{OH} = -4.0 \text{ mA}$	2.4	-	V	
V_{OL}	Output LOW voltage	$V_{CC} = \text{Min}, I_{OL} = 8.0 \text{ mA}$	-	0.4	V	
V_{IH}	Input HIGH voltage		2.2	6.0	V	
V_{IL}	Input LOW voltage ^[1]		-0.5	0.8	V	
I_{IX}	Input leakage current	$GND \leq V_I \leq V_{CC}$	Commercial / Industrial	-1	+1	μA
			Automotive-A	-1	+1	μA
			Automotive-E	-4	+4	μA
I_{OZ}	Output leakage current	$GND \leq V_I \leq V_{CC}$, Output Disabled	Commercial / Industrial	-1	+1	μA
			Automotive-A	-1	+1	μA
			Automotive-E	-4	+4	μA
I_{CC}	V_{CC} operating supply current	$V_{CC} = \text{Max}$, $I_{OUT} = 0 \text{ mA}$, $f = f_{MAX} = 1/t_{RC}$	Commercial / Industrial	-	130	mA
			Automotive-A	-	130	
			Automotive-E	-	130	
I_{SB1}	Automatic CE power down current – TTL inputs	Max V_{CC} , $\overline{CE} \geq V_{IH}$, $V_{IN} \geq V_{IH}$ or $V_{IN} \leq V_{IL}$, $f = f_{MAX}$	Commercial / Industrial	-	40	mA
			Automotive-A	-	40	
			Automotive-E	-	50	
I_{SB2}	Automatic CE power down current – CMOS inputs	Max V_{CC} , $CE \geq V_{CC} - 0.3 \text{ V}$, $V_{IN} \geq V_{CC} - 0.3 \text{ V}$, or $V_{IN} \leq 0.3 \text{ V}$, $f = 0$	Commercial / Industrial	-	10	mA
			Commercial / Industrial (L)	-	0.5	
			Automotive-A (L)	-	0.5	
			Automotive-E	-	15	

Notes

- V_{IL} (min.) = -2.0 V and V_{IH} (max) = $V_{CC} + 0.5$ V for pulse durations of less than 20 ns.
- T_A is the "Instant On" case temperature.

Capacitance

Parameter ^[3]	Description	Test Conditions	Max	Unit
C_{IN}	Input capacitance	$T_A = 25\text{ }^\circ\text{C}$, $f = 1\text{ MHz}$, $V_{CC} = 5.0\text{ V}$	8	pF
C_{OUT}	Output capacitance		8	pF

Thermal Resistance

Parameter ^[3]	Description	Test Conditions	44-pin SOJ	44-pin TSOP II	Unit
Θ_{JA}	Thermal resistance (junction to ambient)	Test conditions follow standard test methods and procedures for measuring thermal impedance, per EIA / JESD51.	64.32	76.89	$^\circ\text{C/W}$
Θ_{JC}	Thermal resistance (junction to case)		31.03	14.28	$^\circ\text{C/W}$

AC Test Loads and Waveforms

Figure 2. AC Test Loads and Waveforms

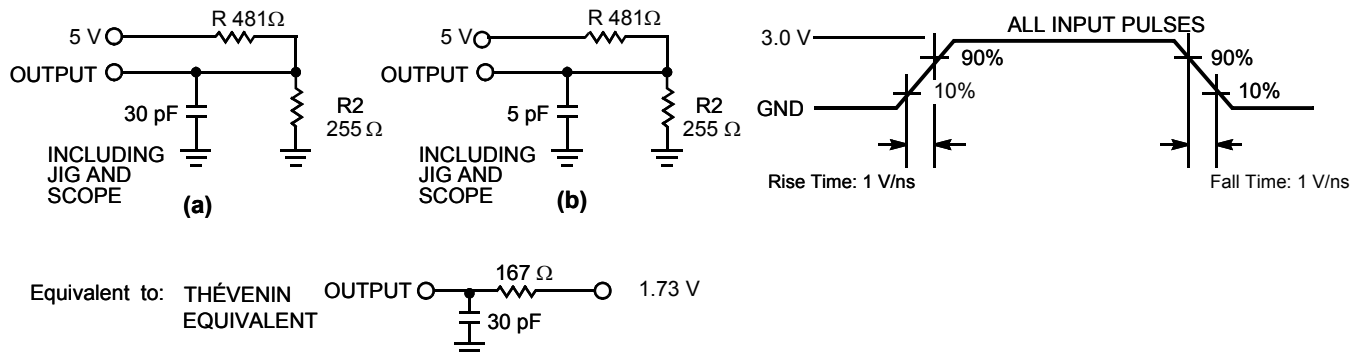

Note

3. Tested initially and after any design or process changes that may affect these parameters.



Switching Characteristics

Over the operating range

Parameter ^[4]	Description	-15		Unit
		Min	Max	
Read Cycle				
t_{RC}	Read cycle time	15	–	ns
t_{AA}	Address to data valid	–	15	ns
t_{OHA}	Data hold from address change	3	–	ns
t_{ACE}	\overline{CE} LOW to data valid	–	15	ns
t_{DOE}	\overline{OE} LOW to data valid	–	7	ns
t_{LZOE}	\overline{OE} LOW to low Z ^[4]	0	–	ns
t_{HZOE}	\overline{OE} HIGH to high Z ^[5, 6]	–	7	ns
t_{LZCE}	\overline{CE} LOW to low Z ^[5]	3	–	ns
t_{HZCE}	\overline{CE} HIGH to high Z ^[5, 6]	–	7	ns
t_{PU}	\overline{CE} LOW to power up	0	–	ns
t_{PD}	\overline{CE} HIGH to power down	–	15	ns
t_{DBE}	Byte enable to data valid	–	7	ns
t_{LZBE}	Byte enable to low Z ^[5]	0	–	ns
t_{HZBE}	Byte disable to high Z ^[5, 6]	–	7	ns
Write Cycle ^[7, 8]				
t_{WC}	Write cycle time	15	–	ns
t_{SCE}	\overline{CE} LOW to write end	10	–	ns
t_{AW}	Address setup to write end	10	–	ns
t_{HA}	Address hold from write end	0	–	ns
t_{SA}	Address setup to write start	0	–	ns
t_{PWE}	\overline{WE} pulse width	12	–	ns
t_{SD}	Data setup to write end	8	–	ns
t_{HD}	Data hold from write end	0	–	ns
t_{LZWE}	\overline{WE} HIGH to low Z ^[5]	3	–	ns
t_{HZWE}	\overline{WE} LOW to high Z ^[5, 6]	–	7	ns
t_{BW}	Byte enable to write end	9	–	ns

Notes

- Test conditions assume signal transition time of 3 ns or less, timing reference levels of 1.5 V, input pulse levels of 0 to 3.0 V, and output loading of the specified I_{OL}/I_{OH} and 30 pF load capacitance.
- At any temperature and voltage condition, t_{HZCE} is less than t_{LZCE} , t_{HZOE} is less than t_{LZOE} , t_{HZBE} is less than t_{LZBE} , and t_{HZWE} is less than t_{LZWE} for any device.
- t_{HZOE} , t_{HZBE} , t_{HZCE} , and t_{HZWE} are specified with a load capacitance of 5 pF as in part (b) of [Figure 2 on page 6](#). Transition is measured ± 500 mV from steady-state voltage.
- The internal write time of the memory is defined by the overlap of \overline{CE} LOW, \overline{WE} LOW, and $\overline{BHE} / \overline{BLE}$ LOW. \overline{CE} , \overline{WE} , and $\overline{BHE} / \overline{BLE}$ must be LOW to initiate a write, and the transition of these signals can terminate the write. The input data setup and hold timing should be referenced to the leading edge of the signal that terminates the write.
- The minimum write cycle pulse width for the Write Cycle No. 3 (\overline{WE} Controlled, \overline{OE} LOW) should be equal to sum of t_{SD} and t_{HZWE} .

Switching Waveforms

Figure 3. Read Cycle No. 1 [9, 10]

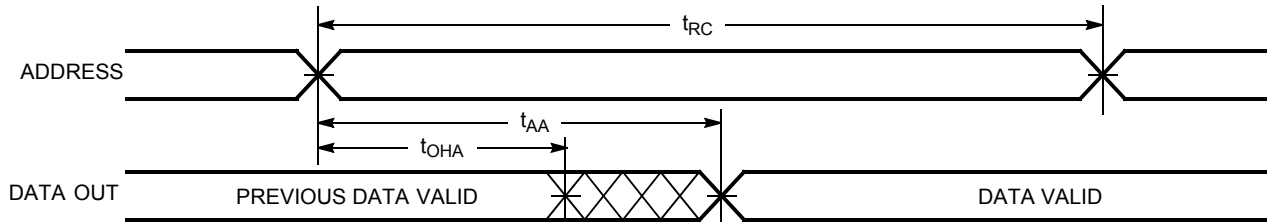
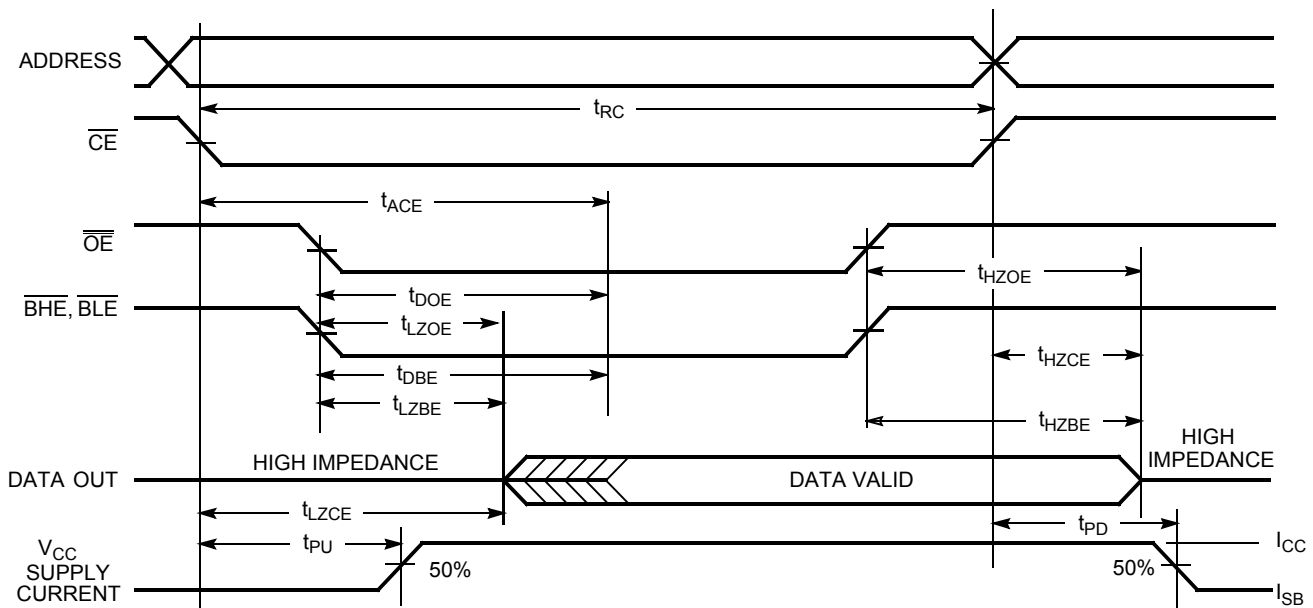

Figure 4. Read Cycle No. 2 (\overline{OE} Controlled) [10, 11]



Notes

9. Device is continuously selected. \overline{OE} , \overline{CE} , \overline{BHE} , and \overline{BLE} = V_{IL} .

10. \overline{WE} is HIGH for read cycle.

11. Address valid prior to or coincident with \overline{CE} transition LOW.

Switching Waveforms (continued)

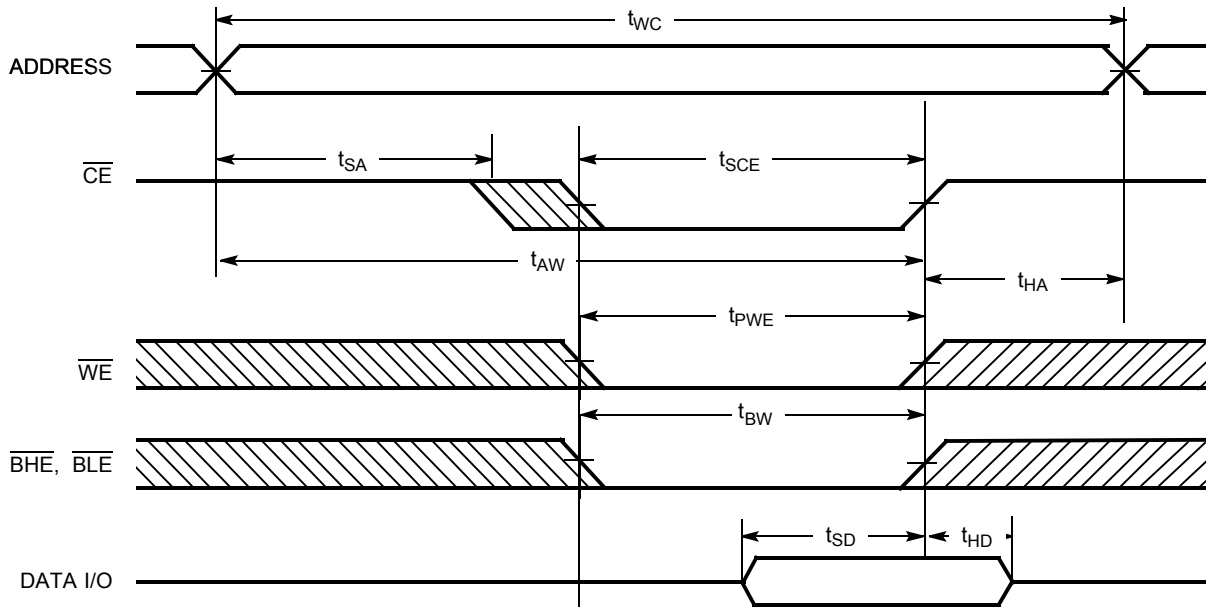
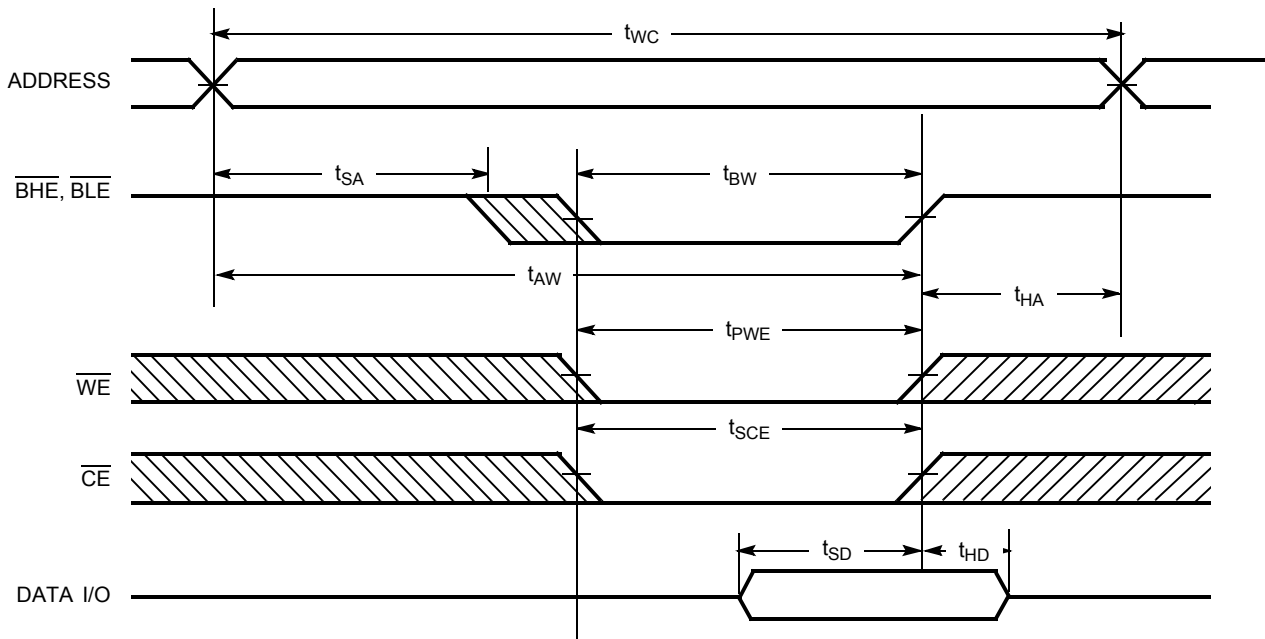
Figure 5. Write Cycle No. 1 ($\overline{\text{CE}}$ Controlled) [12, 13]

Figure 6. Write Cycle No. 2 ($\overline{\text{BLE}}$ or $\overline{\text{BHE}}$ Controlled)

Notes

 12. Data I/O is high impedance if $\overline{\text{OE}}$ or $\overline{\text{BHE}}$ and/or $\overline{\text{BLE}} = V_{IH}$.

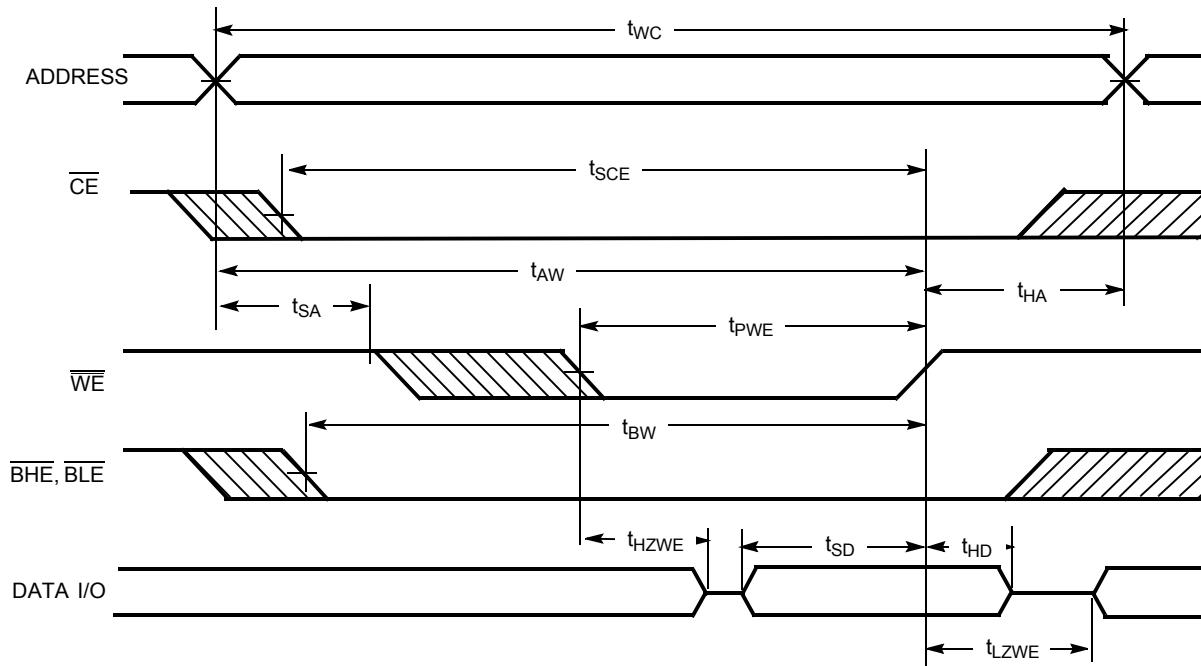
 13. If $\overline{\text{CE}}$ goes HIGH simultaneously with $\overline{\text{WE}}$ going HIGH, the output remains in a high impedance state.

Switching Waveforms (continued)

Figure 7. Write Cycle No. 3 (\overline{WE} Controlled, \overline{OE} LOW)



Truth Table

$\overline{\text{CE}}$	$\overline{\text{OE}}$	$\overline{\text{WE}}$	$\overline{\text{BLE}}$	$\overline{\text{BHE}}$	I/O ₁ –I/O ₈	I/O ₉ –I/O ₁₆	Mode	Power
H	X	X	X	X	High Z	High Z	Power down	Standby (I _{SB})
L	L	H	L	L	Data out	Data out	Read - All bits	Active (I _{CC})
			L	H	Data out	High Z	Read - Lower bits only	Active (I _{CC})
			H	L	High Z	Data out	Read - Upper bits only	Active (I _{CC})
L	X	L	L	L	Data In	Data In	Write - All bits	Active (I _{CC})
			L	H	Data In	High Z	Write - Lower bits only	Active (I _{CC})
			H	L	High Z	Data In	Write - Upper bits only	Active (I _{CC})
L	H	H	X	X	High Z	High Z	Selected, outputs disabled	Active (I _{CC})
L	X	X	H	H	High Z	High Z	Selected, outputs disabled	Active (I _{CC})



Ordering Information

Cypress offers other versions of this product type in many different configurations and features. The following table contains only the list of parts that are currently available. For a complete listing of all options, refer to the product summary page at <http://www.cypress.com/products> or contact your local sales representative.

Cypress maintains a worldwide network of offices, solution centers, manufacturers' representatives and distributors. To find the office closest to you, visit us at <http://www.cypress.com/go/datasheet/offices>.

Speed (ns)	Ordering Code	Package Diagram	Package Type	Operating Range
15	CY7C1021BNL-15VXC	51-85082	44-pin (400-mil) Molded SOJ (Pb-free)	Commercial
	CY7C1021BNL-15ZXI	51-85087	44-pin TSOP Type II (Pb-free)	Industrial
	CY7C1021BNL-15ZSXA	51-85087	44-pin TSOP Type II (Pb-free)	Automotive-A
	CY7C1021BN-15ZSXE			Automotive-E

Ordering Code Definitions

CY 7 C 1 02 1 X BN L - 15 XX X X

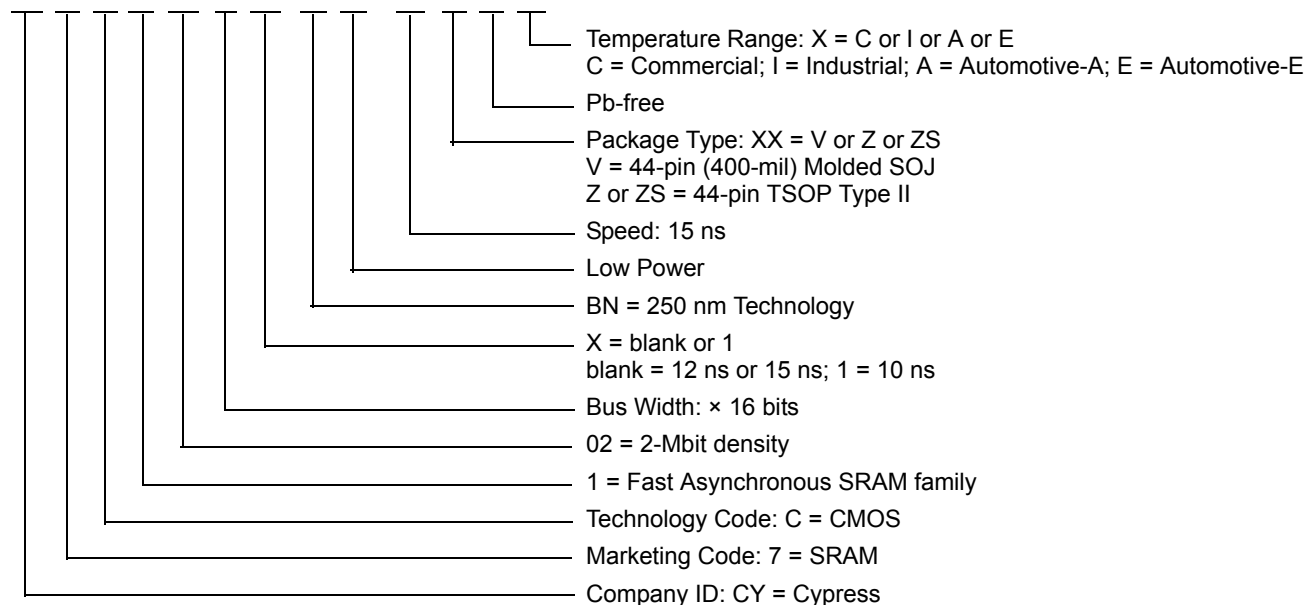

Package Diagrams

Figure 8. 44-pin SOJ (400 Mils) V44.4 Package Outline, 51-85082

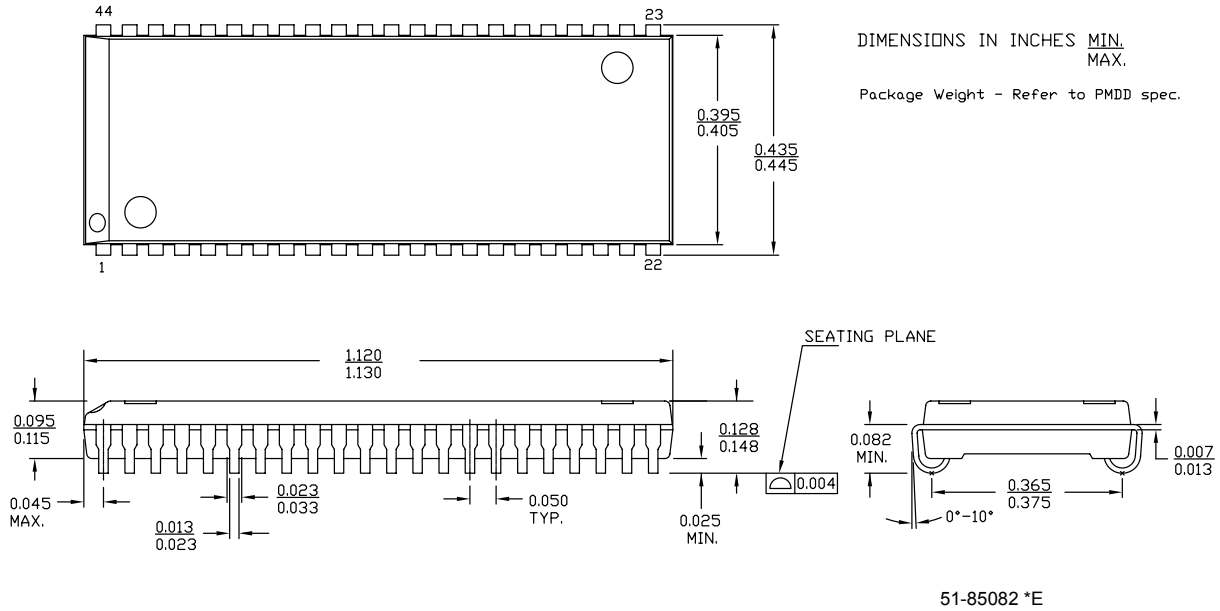
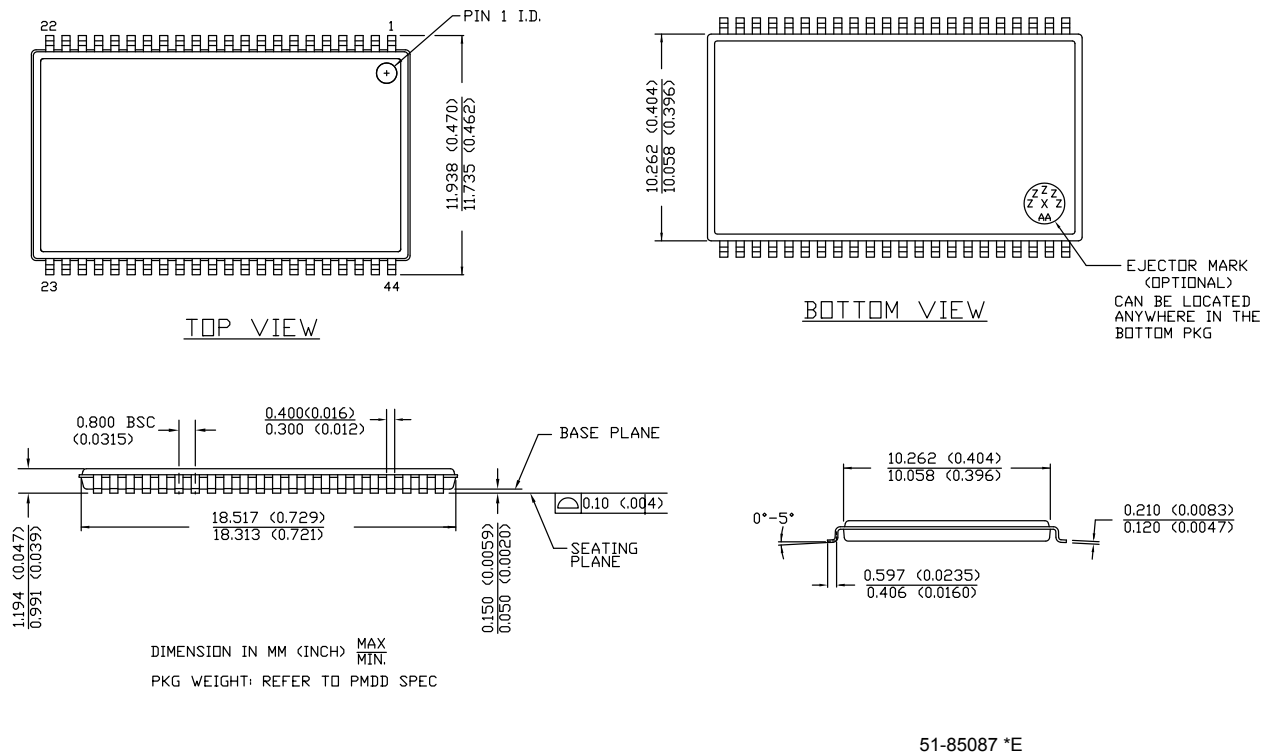

Figure 9. 44-pin TSOP Z44-II Package Outline, 51-85087





Acronyms

Acronym	Description
$\overline{\text{BHE}}$	Byte High Enable
$\overline{\text{BLE}}$	Byte Low Enable
$\overline{\text{CE}}$	Chip Enable
CMOS	Complementary Metal Oxide Semiconductor
I/O	Input/Output
$\overline{\text{OE}}$	Output Enable
SOJ	Small Outline J-lead
SRAM	Static Random Access Memory
TSOP	Thin Small Outline Package
TTL	Transistor-Transistor Logic
$\overline{\text{WE}}$	Write Enable

Document Conventions

Units of Measure

Symbol	Unit of Measure
$^{\circ}\text{C}$	degree Celsius
MHz	megahertz
μA	microampere
mA	milliampere
mm	millimeter
mW	milliwatt
ns	nanosecond
Ω	ohm
%	percent
pF	picofarad
V	volt
W	watt



Document History Page

Document Title: CY7C1021BN, 1-Mbit (64 K × 16) Static RAM				
Document Number: 001-06494				
Rev.	ECN No.	Submission Date	Orig. of Change	Description of Change
**	423877	See ECN	NXR	New data sheet.
*A	505726	See ECN	NXR	Removed I _{OS} parameter from DC Electrical Characteristics table. Updated Ordering Information (Added Automotive products).
*B	2897061	03/22/10	AJU	Updated Ordering Information (Removed obsolete parts). Updated Package Diagrams .
*C	2947254	06/08/10	RAME	Updated Pin Definitions (Replaced "Byte write select inputs" with "Byte Enable select inputs" in description of pin BHE, BLE). Updated AC Test Loads and Waveforms (Updated Figure 2 (Added ohm (Ω) symbol in Thevenin equivalent circuit)). Updated Switching Characteristics (Updated Note 5 (Included t _{HZBE} and t _{LZBE} in the note)). Updated Ordering Information (Included operating range for CY7C1021BNL-15ZXI in ordering information table).
*D	3328634	26/07/2011	AJU	Updated Features (Removed the information associated with speed bins -10 and -12). Removed the note "For best practice recommendations, refer to the Cypress application note, SRAM System Design Guidelines-AN1064." in page 1 and its reference in Functional Description . Updated Functional Description (Removed the information associated with speed bins -10 and -12). Updated Selection Guide (Removed the information associated with speed bins -10 and -12). Updated Electrical Characteristics (Removed the information associated with speed bins -10 and -12). Updated Switching Characteristics (Removed the information associated with speed bins -10 and -12). Updated Ordering Information . Added Acronyms and Units of Measure . Updated to new template.
*E	4125119	09/16/2013	VINI	Updated Package Diagrams : spec 51-85082 – Changed revision from *C to *E. spec 51-85087 – Changed revision from *C to *E. Updated to new template. Completing Sunset Review.
*F	4545523	10/20/2014	VINI	Updated Document Title to read as "CY7C1021BN, 1-Mbit (64 K × 16) Static RAM". Removed CY7C10211BN related information in all instances across the document. Updated Switching Characteristics : Removed "CY7C1021B" and retained "-15" in column heading "CY7C1021B-15". Added Note 8 and referred the same note in "Write Cycle". Added t _{PWE} parameter and its details. Completing Sunset Review.
*G	4557296	10/31/2014	VINI	Updated Switching Characteristics : Updated minimum and maximum values of t _{PWE} parameter.
*H	4578500	12/16/2014	VINI	Updated Ordering Information : Removed the prune part number CY7C1021BN-15VXE.
*I	4984333	10/23/2015	NILE	Updated to new template. Completing Sunset Review.
*J	5979549	11/29/2017	AESATMP9	Updated logo and copyright.



Sales, Solutions, and Legal Information

Worldwide Sales and Design Support

Cypress maintains a worldwide network of offices, solution centers, manufacturer's representatives, and distributors. To find the office closest to you, visit us at [Cypress Locations](#).

Products

ARM® Cortex® Microcontrollers	cypress.com/arm
Automotive	cypress.com/automotive
Clocks & Buffers	cypress.com/clocks
Interface	cypress.com/interface
Internet of Things	cypress.com/iot
Memory	cypress.com/memory
Microcontrollers	cypress.com/mcu
PSoC	cypress.com/psoc
Power Management ICs	cypress.com/pmic
Touch Sensing	cypress.com/touch
USB Controllers	cypress.com/usb
Wireless Connectivity	cypress.com/wireless

PSoC® Solutions

[PSoC 1](#) | [PSoC 3](#) | [PSoC 4](#) | [PSoC 5LP](#) | [PSoC 6](#)

Cypress Developer Community

[Forums](#) | [WICED IOT Forums](#) | [Projects](#) | [Video](#) | [Blogs](#) | [Training](#) | [Components](#)

Technical Support

cypress.com/support

© Cypress Semiconductor Corporation, 2006-2017. This document is the property of Cypress Semiconductor Corporation and its subsidiaries, including Spansion LLC ("Cypress"). This document, including any software or firmware included or referenced in this document ("Software"), is owned by Cypress under the intellectual property laws and treaties of the United States and other countries worldwide. Cypress reserves all rights under such laws and treaties and does not, except as specifically stated in this paragraph, grant any license under its patents, copyrights, trademarks, or other intellectual property rights. If the Software is not accompanied by a license agreement and you do not otherwise have a written agreement with Cypress governing the use of the Software, then Cypress hereby grants you a personal, non-exclusive, nontransferable license (without the right to sublicense) (1) under its copyright rights in the Software (a) for Software provided in source code form, to modify and reproduce the Software solely for use with Cypress hardware products, only internally within your organization, and (b) to distribute the Software in binary code form externally to end users (either directly or indirectly through resellers and distributors), solely for use on Cypress hardware product units, and (2) under those claims of Cypress's patents that are infringed by the Software (as provided by Cypress, unmodified) to make, use, distribute, and import the Software solely for use with Cypress hardware products. Any other use, reproduction, modification, translation, or compilation of the Software is prohibited.

TO THE EXTENT PERMITTED BY APPLICABLE LAW, CYPRESS MAKES NO WARRANTY OF ANY KIND, EXPRESS OR IMPLIED, WITH REGARD TO THIS DOCUMENT OR ANY SOFTWARE OR ACCOMPANYING HARDWARE, INCLUDING, BUT NOT LIMITED TO, THE IMPLIED WARRANTIES OF MERCHANTABILITY AND FITNESS FOR A PARTICULAR PURPOSE. To the extent permitted by applicable law, Cypress reserves the right to make changes to this document without further notice. Cypress does not assume any liability arising out of the application or use of any product or circuit described in this document. Any information provided in this document, including any sample design information or programming code, is provided only for reference purposes. It is the responsibility of the user of this document to properly design, program, and test the functionality and safety of any application made of this information and any resulting product. Cypress products are not designed, intended, or authorized for use as critical components in systems designed or intended for the operation of weapons, weapons systems, nuclear installations, life-support devices or systems, other medical devices or systems (including resuscitation equipment and surgical implants), pollution control or hazardous substances management, or other uses where the failure of the device or system could cause personal injury, death, or property damage ("Unintended Uses"). A critical component is any component of a device or system whose failure to perform can be reasonably expected to cause the failure of the device or system, or to affect its safety or effectiveness. Cypress is not liable, in whole or in part, and you shall and hereby do release Cypress from any claim, damage, or other liability arising from or related to all Unintended Uses of Cypress products. You shall indemnify and hold Cypress harmless from and against all claims, costs, damages, and other liabilities, including claims for personal injury or death, arising from or related to any Unintended Uses of Cypress products.

Cypress, the Cypress logo, Spansion, the Spansion logo, and combinations thereof, WICED, PSoC, CapSense, EZ-USB, F-RAM, and Traveo are trademarks or registered trademarks of Cypress in the United States and other countries. For a more complete list of Cypress trademarks, visit cypress.com. Other names and brands may be claimed as property of their respective owners.

OUR CERTIFICATE

DiGi provide top-quality products and perfect service for customer worldwide through standardization, technological innovation and continuous improvement. DiGi through third-party certification, we stricly control the quality of products and services. Welcome your RFQ to

Email: Info@DiGi-Electronics.com



Tel: +00 852-30501935

RFQ Email: Info@DiGi-Electronics.com

DiGi is a global authorized distributor of electronic components.