

CY7C1021CV26-15ZSXET Datasheet

www.digi-electronics.com

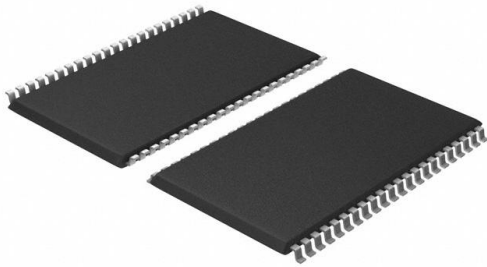

<https://www.DiGi-Electronics.com>

DiGi Electronics Part Number	CY7C1021CV26-15ZSXET-DG
Manufacturer	Infineon Technologies
Manufacturer Product Number	CY7C1021CV26-15ZSXET
Description	IC SRAM 1MBIT PARALLEL 44TSOP II
Detailed Description	SRAM - Asynchronous Memory IC 1Mbit Parallel 15 ns 44-TSOP II

This model CY7C1021CV26-15ZSXET is available at DiGi Electronics.

DiGi Electronics offers a global database of semiconductor and electronic component datasheets.

We welcome your inquiries regarding pricing, lead time, or other product-related questions.

 [Request a Quote](#)

 [Datasheet Search](#)



Tel: +00 852-30501935

RFQ Email: Info@DiGi-Electronics.com

DiGi is a global authorized distributor of electronic components.

Purchase and inquiry

Manufacturer Product Number:

CY7C1021CV26-15ZSXET

Series:

-

DiGi-Electronics Programmable:

Not Verified

Memory Format:

SRAM

Memory Size:

1Mbit

Memory Interface:

Parallel

Access Time:

15 ns

Operating Temperature:

-40°C ~ 125°C (TA)

Package / Case:

44-TSOP (0.400", 10.16mm Width)

Base Product Number:

CY7C1021

Manufacturer:

Infineon Technologies

Product Status:

Obsolete

Memory Type:

Volatile

Technology:

SRAM - Asynchronous

Memory Organization:

64K x 16

Write Cycle Time - Word, Page:

15ns

Voltage - Supply:

2.5V ~ 2.7V

Mounting Type:

Surface Mount

Supplier Device Package:

44-TSOP II

Environmental & Export classification

RoHS Status:

ROHS3 Compliant

REACH Status:

REACH Unaffected

HTSUS:

8542.32.0041

Moisture Sensitivity Level (MSL):

3 (168 Hours)

ECCN:

3A991B2B



CY7C1021CV26

1-Mbit (64 K × 16) Static RAM

Features

- Temperature Range
 - Automotive: -40 °C to 125 °C
- High speed
 - $t_{AA} = 15 \text{ ns}$
- Optimized voltage range: 2.5 V to 2.7 V
- Low active power: 220 mW (Max)
- Automatic power-down when deselected
- Independent control of upper and lower bits
- CMOS for optimum speed/power
- Available in Pb-free and non Pb-free 44-pin TSOP II, 44-pin (400-Mil) Molded SOJ and Pb-free 48-ball FBGA packages

Functional Description

The CY7C1021CV26 is a high-performance CMOS static RAM organized as 65,536 words by 16 bits. This device has an automatic power-down feature that significantly reduces power consumption when deselected.

Writing to the device is accomplished by taking Chip Enable (\overline{CE}) and Write Enable (WE) inputs LOW. If Byte Low Enable (BLE) is LOW, then data from I/O pins (I/O₀ through I/O₇), is written into the location specified on the address pins (A₀ through A₁₅). If Byte High Enable (BHE) is LOW, then data from I/O pins (I/O₈ through I/O₁₅) is written into the location specified on the address pins (A₀ through A₁₅).

Reading from the device is accomplished by taking Chip Enable (\overline{CE}) and Output Enable (\overline{OE}) LOW while forcing the Write Enable (WE) HIGH. If Byte Low Enable (BLE) is LOW, then data from the memory location specified by the address pins will appear on I/O₀ to I/O₇. If Byte High Enable (BHE) is LOW, then data from memory will appear on I/O₈ to I/O₁₅. See the truth table at the end of this data sheet for a complete description of Read and Write modes.

The input/output pins (I/O₀ through I/O₁₅) are placed in a high-impedance state when the device is deselected (\overline{CE} HIGH), the outputs are disabled (\overline{OE} HIGH), the BHE and BLE are disabled (\overline{BHE} , BLE HIGH), or during a Write operation (\overline{CE} LOW, and WE LOW).

For a complete list of related resources, [click here](#).

Logic Block Diagram

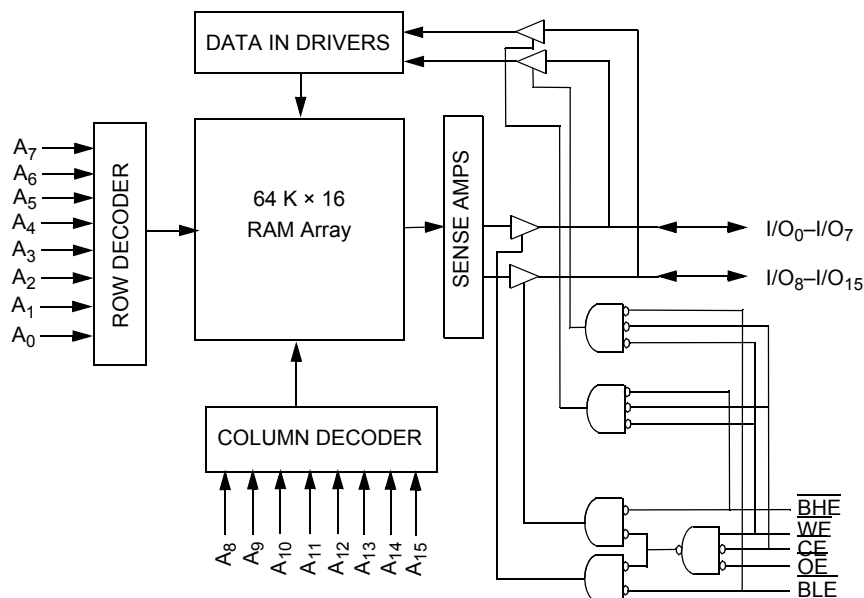



Contents

Selection Guide	3	Package Diagrams	13
Pin Configurations	3	Acronyms	15
Pin Definitions	4	Document Conventions	15
Maximum Ratings	5	Units of Measure	15
Operating Range	5	Document History Page	16
Electrical Characteristics	5	Sales, Solutions, and Legal Information	17
Capacitance	6	Worldwide Sales and Design Support	17
Thermal Resistance	6	Products	17
AC Test Loads and Waveforms	6	PSoC® Solutions	17
Switching Characteristics	7	Cypress Developer Community	17
Switching Waveforms	8	Technical Support	17
Truth Table	11		
Ordering Information	12		
Ordering Code Definitions	12		



Selection Guide

Description ^[1]	-15	Unit
Maximum Access Time	15	ns
Maximum Operating Current	80	mA
Maximum CMOS Standby Current	10	mA

Pin Configurations

Figure 1. 44-pin SOJ/TSOP II pinout ^[2]

A ₄	1	44	A ₅
A ₃	2	43	A ₆
A ₂	3	42	A ₇
A ₁	4	41	OE
A ₀	5	40	BHE
CE	6	39	BLE
I/O ₀	7	38	I/O ₁₅
I/O ₁	8	37	I/O ₁₄
I/O ₂	9	36	I/O ₁₃
I/O ₃	10	35	I/O ₁₂
V _{CC}	11	34	V _{SS}
V _{SS}	12	33	V _{CC}
I/O ₄	13	32	I/O ₁₁
I/O ₅	14	31	I/O ₁₀
I/O ₆	15	30	I/O ₉
I/O ₇	16	29	I/O ₈
WE	17	28	NC
A ₁₅	18	27	A ₈
A ₁₄	19	26	A ₉
A ₁₃	20	25	A ₁₀
A ₁₂	21	24	A ₁₁
NC	22	23	NC

Figure 2. 48-ball FBGA pinout ^[2]

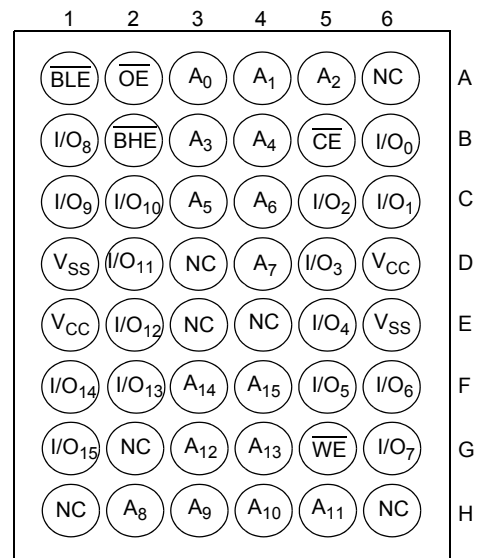

Notes

- Typical values are included for reference only and are not guaranteed or tested. Typical values are measured at $V_{CC} = V_{CC(typ)}$, $T_A = 25\text{ }^\circ\text{C}$.
- NC pins are not connected on the die.



Pin Definitions

Pin Name	Pin Number	I/O Type	Description
A ₀ -A ₁₅	1-5, 18-21, 24-27, 42-44	Input	Address Inputs used to select one of the address locations.
I/O ₀ -I/O ₁₅	7-10, 13-16, 29-32, 35-38	Input/Output	Bidirectional Data I/O lines. Used as input or output lines depending on operation.
NC	22, 23, 28	No Connect	No Connects. This pin is not connected to the die.
WE	17	Input/Control	Write Enable Input, active LOW. When selected LOW, a Write is conducted. When selected HIGH, a Read is conducted.
CE	6	Input/Control	Chip Enable Input, active LOW. When LOW, selects the chip. When HIGH, deselects the chip.
$\overline{\text{BHE}}$, $\overline{\text{BLE}}$	40, 39	Input/Control	Byte Write Select Inputs, active LOW. $\overline{\text{BHE}}$ controls I/O ₁₅ -I/O ₈ , $\overline{\text{BLE}}$ controls I/O ₇ -I/O ₀ .
OE	41	Input/Control	Output Enable, active LOW. Controls the direction of the I/O pins. When LOW, the I/O pins are allowed to behave as outputs. When de-asserted HIGH, I/O pins are tri-stated, and act as input data pins.
V _{SS}	12, 34	Ground	Ground for the device. Should be connected to ground of the system.
V _{CC}	11, 33	Power Supply	Power Supply inputs to the device.



Maximum Ratings

Exceeding maximum ratings may shorten the useful life of the device. User guidelines are not tested.

Storage temperature	-65 °C to +150 °C
Ambient temperature with power applied	-55 °C to +125 °C
Supply voltage on V_{CC} to relative GND ^[3]	-0.5 V to +4.6 V
DC voltage applied to outputs in high Z state ^[3]	-0.5 V to $V_{CC} + 0.5$ V

DC input voltage ^[3]	-0.5 V to $V_{CC} + 0.5$ V
Current into outputs (LOW)	20 mA
Static discharge voltage (per MIL-STD-883, method 3015)	> 2001 V
Latch-up current	> 200 mA

Operating Range

Range	Ambient Temperature	V_{CC}
Automotive	-40 °C to +125 °C	2.5 V–2.7 V

Electrical Characteristics

Over the Operating Range

Parameter	Description	Test Conditions	-15		Unit
			Min	Max	
V_{OH}	Output HIGH voltage	$V_{CC} = \text{Min}, I_{OH} = -1.0 \text{ mA}$	2.3	–	V
V_{OL}	Output LOW voltage	$V_{CC} = \text{Min}, I_{OL} = 1.0 \text{ mA}$	–	0.4	V
V_{IH}	Input HIGH voltage		2.0	$V_{CC} + 0.3$	V
V_{IL}	Input LOW voltage ^[3]		-0.3	0.8	V
I_{IX}	Input leakage current	$GND \leq V_I \leq V_{CC}$	-3	+3	μA
I_{OZ}	Output leakage current	$GND \leq V_I \leq V_{CC}$, output disabled	-3	+3	μA
I_{CC}	V_{CC} operating supply current	$V_{CC} = \text{Max}, I_{OUT} = 0 \text{ mA}, f = f_{MAX} = 1/t_{RC}$	–	80	mA
I_{SB1}	Automatic CE power-down Current – TTL inputs	Max V_{CC} , $\overline{CE} \geq V_{IH}$, $V_{IN} \geq V_{IH}$ or $V_{IN} \leq V_{IL}$, $f = f_{MAX}$	–	15	mA
I_{SB2}	Automatic CE power-down Current – CMOS inputs	Max V_{CC} , $\overline{CE} \geq V_{CC} - 0.3 \text{ V}$, $V_{IN} \geq V_{CC} - 0.3 \text{ V}$, or $V_{IN} \leq 0.3 \text{ V}$, $f = 0$	–	10	mA

Note

3. $V_{IL}(\text{min.}) = -2.0\text{V}$ and $V_{IH}(\text{max.}) = V_{CC} + 0.5 \text{ V}$ for pulse durations of less than 20 ns.

Capacitance

Parameter ^[4]	Description	Test Conditions	Max	Unit
C_{IN}	Input capacitance	$T_A = 25\text{ }^\circ\text{C}$, $f = 1\text{ MHz}$, $V_{CC} = 2.6\text{ V}$	8	pF
C_{OUT}	Output capacitance		8	pF

Thermal Resistance

Parameter ^[4]	Description	Test Conditions	44-pin TSOP II	Unit
Θ_{JA}	Thermal resistance (junction to ambient)	Still Air, soldered on a 3×4.5 inch, four-layer printed circuit board	76.92	$^\circ\text{C/W}$
Θ_{JC}	Thermal resistance (junction to case)		15.86	$^\circ\text{C/W}$

AC Test Loads and Waveforms

Figure 3. AC Test Loads and Waveforms ^[5]

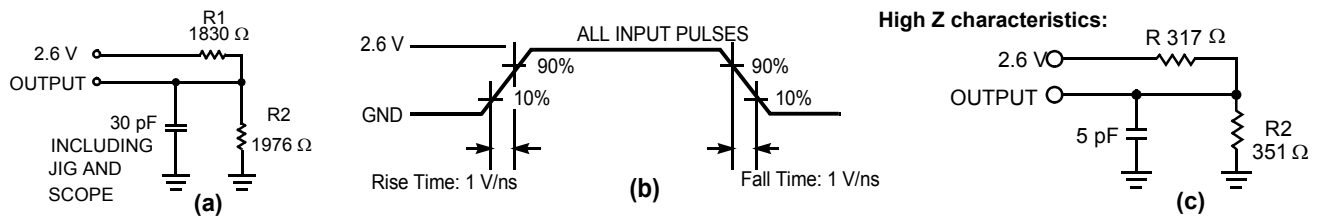

Notes

- Tested initially and after any design or process changes that may affect these parameters.
- AC characteristics (except high Z) are tested using the Thevenin load shown in Figure 3 (a). High Z characteristics are tested for all speeds using the test load shown in Figure 3 (c).



Switching Characteristics

Over the Operating Range

Parameter ^[6]	Description	-15		Unit
		Min	Max	
Read Cycle				
t_{RC}	Read cycle time	15	–	ns
t_{AA}	Address to data valid	–	15	ns
t_{OHA}	Data hold from address change	3	–	ns
t_{ACE}	\overline{CE} LOW to data valid	–	15	ns
t_{DOE}	\overline{OE} LOW to data valid	–	7	ns
t_{LZOE}	\overline{OE} LOW to low Z ^[7]	0	–	ns
t_{HZOE}	\overline{OE} HIGH to high Z ^[7, 8]	–	7	ns
t_{LZCE}	\overline{CE} LOW to low Z ^[7]	3	–	ns
t_{HZCE}	\overline{CE} HIGH to high Z ^[7, 8]	–	7	ns
t_{PU} ^[9]	\overline{CE} LOW to power-up	0	–	ns
t_{PD} ^[9]	\overline{CE} HIGH to power-down	–	15	ns
t_{DBE}	Byte enable to data valid	–	7	ns
t_{LZBE}	Byte enable to low Z	0	–	ns
t_{HZBE}	Byte disable to high Z	–	7	ns
Write Cycle ^[10, 11]				
t_{WC}	Write cycle time	15	–	ns
t_{SCE}	\overline{CE} LOW to write end	10	–	ns
t_{AW}	Address set-up to write end	10	–	ns
t_{HA}	Address hold from write end	0	–	ns
t_{SA}	Address set-up to write start	0	–	ns
t_{PWE}	\overline{WE} pulse width	10	–	ns
t_{SD}	Data set-up to write end	8	–	ns
t_{HD}	Data hold from write end	0	–	ns
t_{LZWE}	\overline{WE} HIGH to low Z ^[7]	3	–	ns
t_{HZWE}	\overline{WE} LOW to high Z ^[7, 8]	–	7	ns
t_{BW}	Byte enable to end of write	9	–	ns

Notes

- Test conditions assume signal transition time of 2.6 ns or less, timing reference levels of 1.3 V, input pulse levels of 0 to 2.6 V.
- At any given temperature and voltage condition, t_{HZCE} is less than t_{LZCE} , t_{HZOE} is less than t_{LZOE} , and t_{HZWE} is less than t_{LZWE} for any given device.
- t_{HZOE} , t_{HZBE} , t_{HZCE} , and t_{HZWE} are specified with a load capacitance of 5 pF as in part (c) of Figure 3. Transition is measured ± 500 mV from steady-state voltage.
- This parameter is guaranteed by design and is not tested.
- The internal Write time of the memory is defined by the overlap of \overline{CE} LOW, \overline{WE} LOW and $\overline{BHE}/\overline{BLE}$ LOW. \overline{CE} , \overline{WE} and $\overline{BHE}/\overline{BLE}$ must be LOW to initiate a Write, and the transition of these signals can terminate the Write. The input data set-up and hold timing should be referenced to the leading edge of the signal that terminates the Write.
- The minimum write pulse width for Write Cycle No. 3 (\overline{WE} Controlled, \overline{OE} LOW) should be sum of t_{SD} and t_{HZWE} .

Switching Waveforms

Figure 4. Read Cycle No. 1 [12, 13]

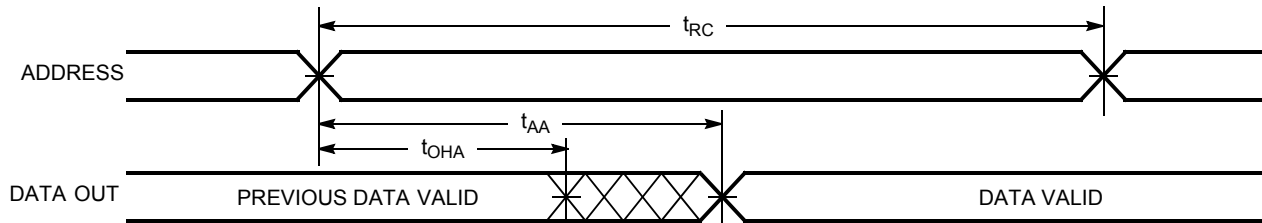
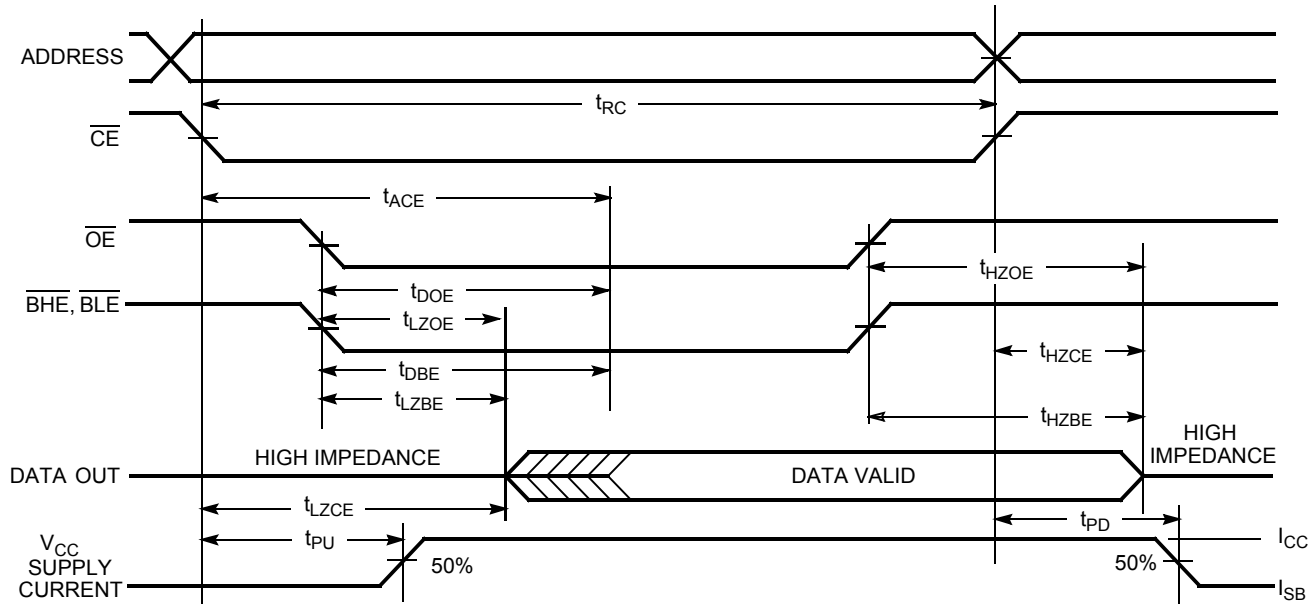
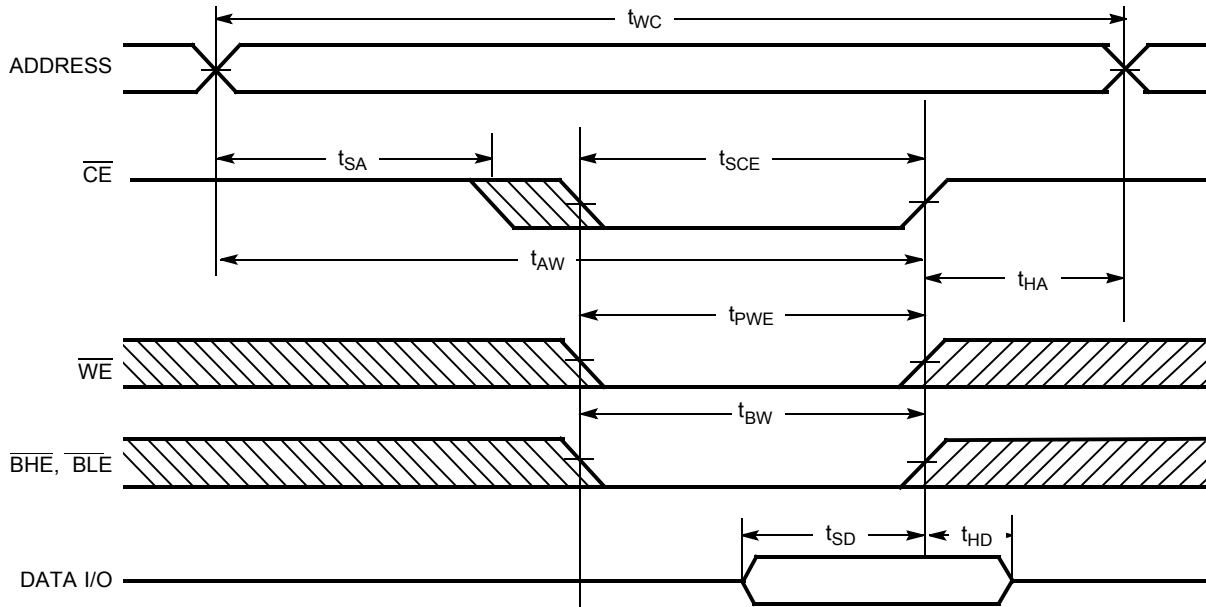
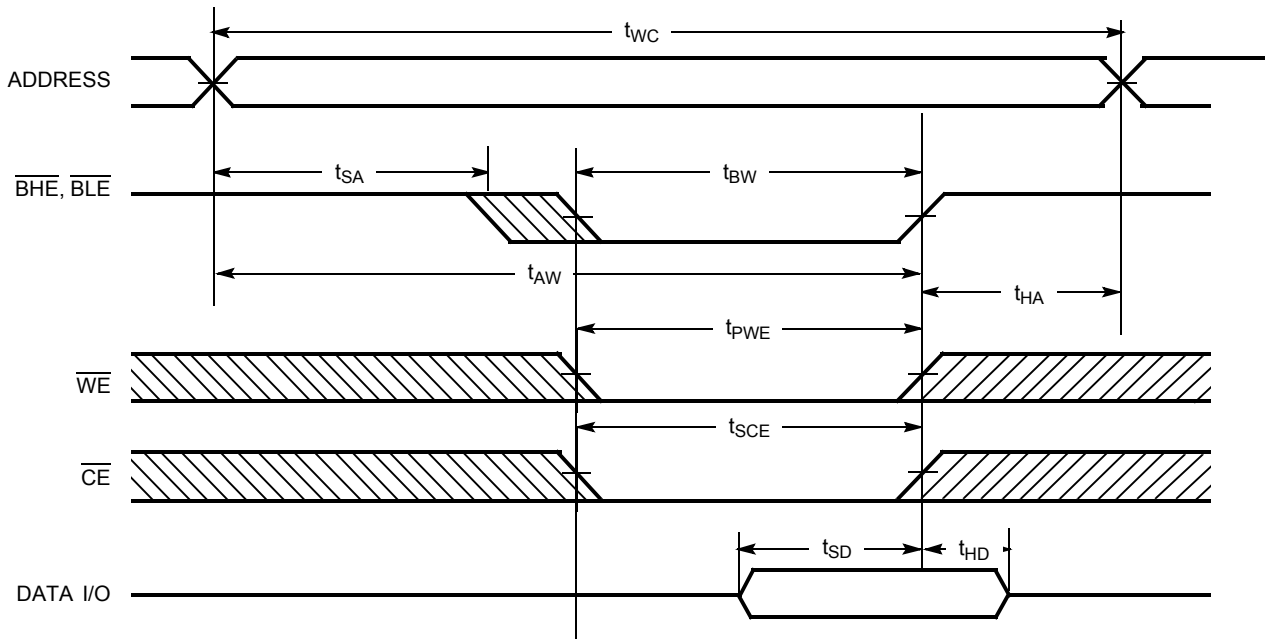

Figure 5. Read Cycle No. 2 (\overline{OE} Controlled) [13, 14]



Notes

12. Device is continuously selected. \overline{OE} , \overline{CE} , \overline{BHE} and/or \overline{BLE} = V_{IL} .
13. \overline{WE} is HIGH for Read cycle.
14. Address valid prior to or coincident with \overline{CE} transition LOW.

Switching Waveforms (continued)**Figure 6. Write Cycle No. 1 ($\overline{\text{CE}}$ Controlled)** [15, 16]**Figure 7. Write Cycle No. 2 ($\overline{\text{BLE}}$ or $\overline{\text{BHE}}$ Controlled)****Notes**

15. Data I/O is high-impedance if $\overline{\text{OE}}$ or $\overline{\text{BHE}}$ and/or $\overline{\text{BLA}} = V_{IH}$.
 16. If $\overline{\text{CE}}$ goes HIGH simultaneously with $\overline{\text{WE}}$ going HIGH, the output remains in a high-impedance state.

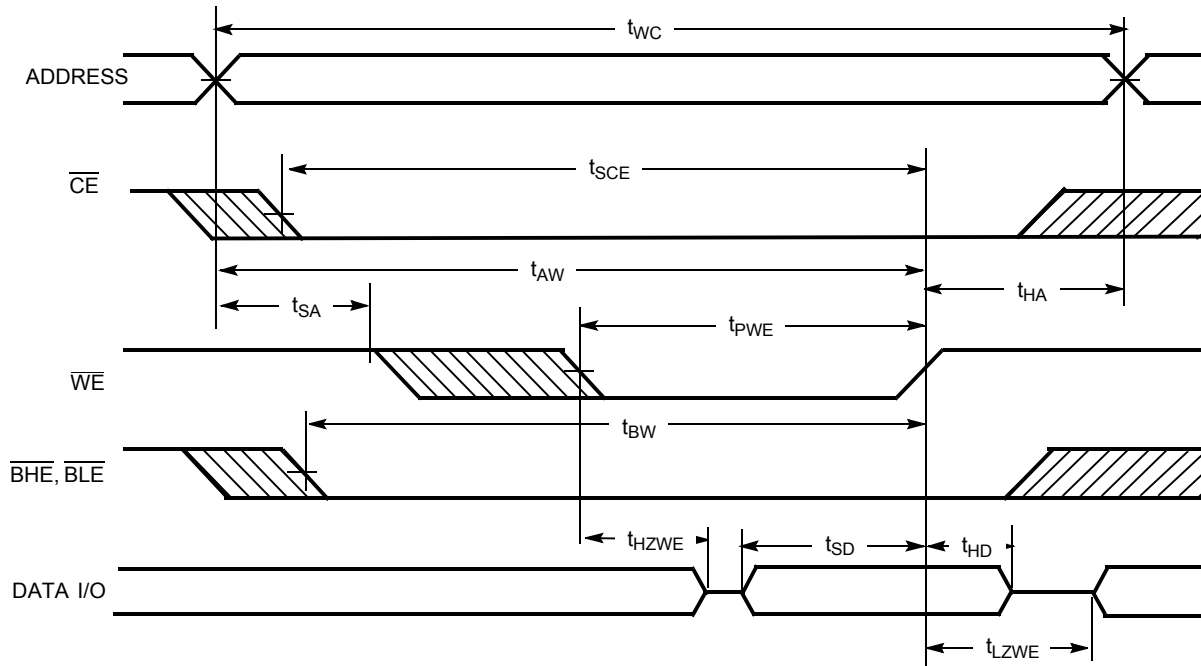
Switching Waveforms (continued)**Figure 8. Write Cycle No. 3 (\overline{WE} Controlled, \overline{OE} LOW) ^[17]****Note**

17. The minimum write pulse width for Write Cycle No. 3 (\overline{WE} controlled, \overline{OE} LOW) should be sum of t_{SD} and t_{HZWE} .



Truth Table

$\overline{\text{CE}}$	$\overline{\text{OE}}$	$\overline{\text{WE}}$	$\overline{\text{BLE}}$	$\overline{\text{BHE}}$	I/O ₀ -I/O ₇	I/O ₈ -I/O ₁₅	Mode	Power
H	X	X	X	X	High Z	High Z	Power-down	Standby (I _{SB})
L	L	H	L	L	Data Out	Data Out	Read – All bits	Active (I _{CC})
			L	H	Data Out	High Z	Read – Lower bits only	Active (I _{CC})
			H	L	High Z	Data Out	Read – Upper bits only	Active (I _{CC})
L	X	L	L	L	Data In	Data In	Write – All bits	Active (I _{CC})
			L	H	Data In	High Z	Write – Lower bits only	Active (I _{CC})
			H	L	High Z	Data In	Write – Upper bits only	Active (I _{CC})
L	H	H	X	X	High Z	High Z	Selected, Outputs Disabled	Active (I _{CC})
L	X	X	H	H	High Z	High Z	Selected, Outputs Disabled	Active (I _{CC})



Ordering Information

Cypress offers other versions of this type of product in many different configurations and features. The following table contains only the list of parts that are currently available. For a complete listing of all options, visit the Cypress website at <http://www.cypress.com> and refer to the product summary page at <http://www.cypress.com/products> or contact your local sales representative.

Cypress maintains a worldwide network of offices, solution centers, manufacturer's representatives and distributors. To find the office closest to you, visit us at <http://www.cypress.com/go/datasheet/offices>.

Speed (ns)	Ordering Code	Package Name	Package Type	Operating Range
15	CY7C1021CV26-15ZSX E	51-85087	44-pin TSOP Type II (Pb-free)	Automotive
	CY7C1021CV26-15ZSX ET	51-85087	44-pin TSOP Type II (Pb-free)	

Ordering Code Definitions

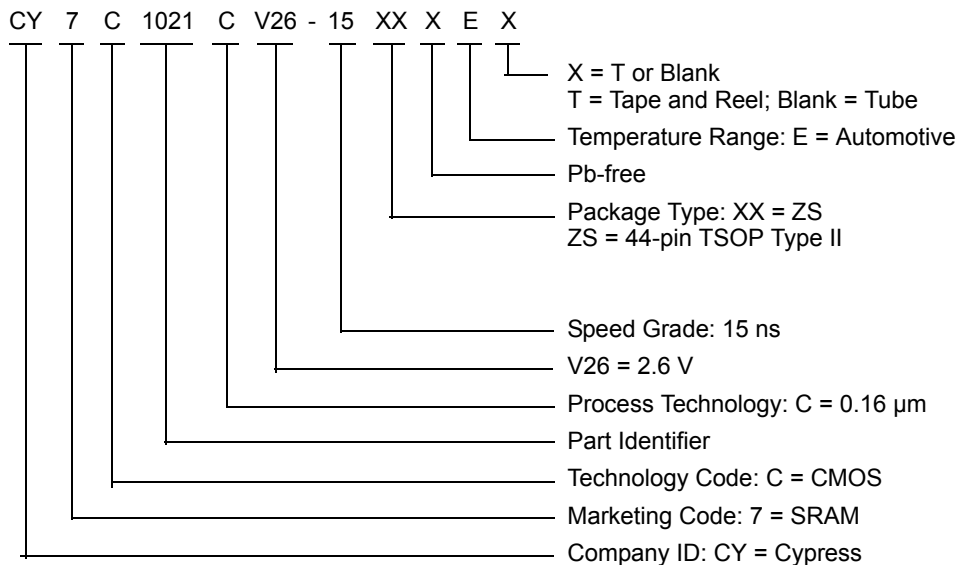

Package Diagrams

Figure 9. 44-pin TSOP Z44-II Package Outline, 51-85087

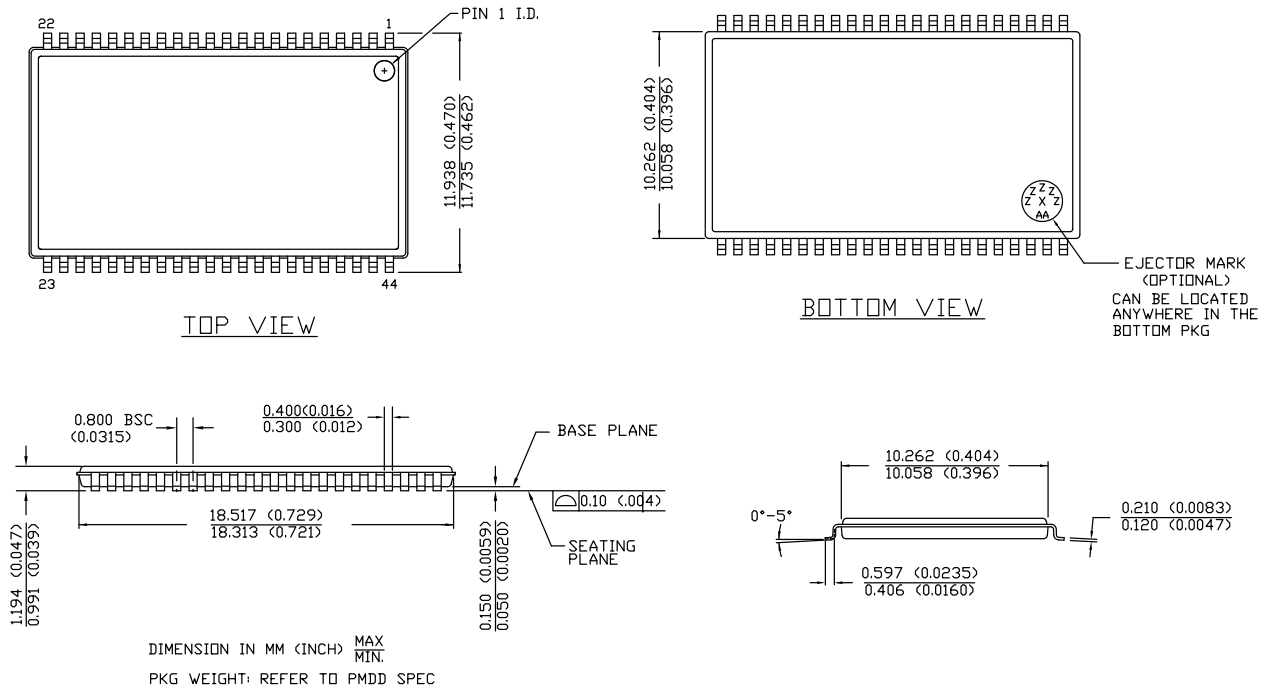

51-85087 *E

Figure 10. 44-pin SOJ (400 Mils) V44.4 Package Outline, 51-85082

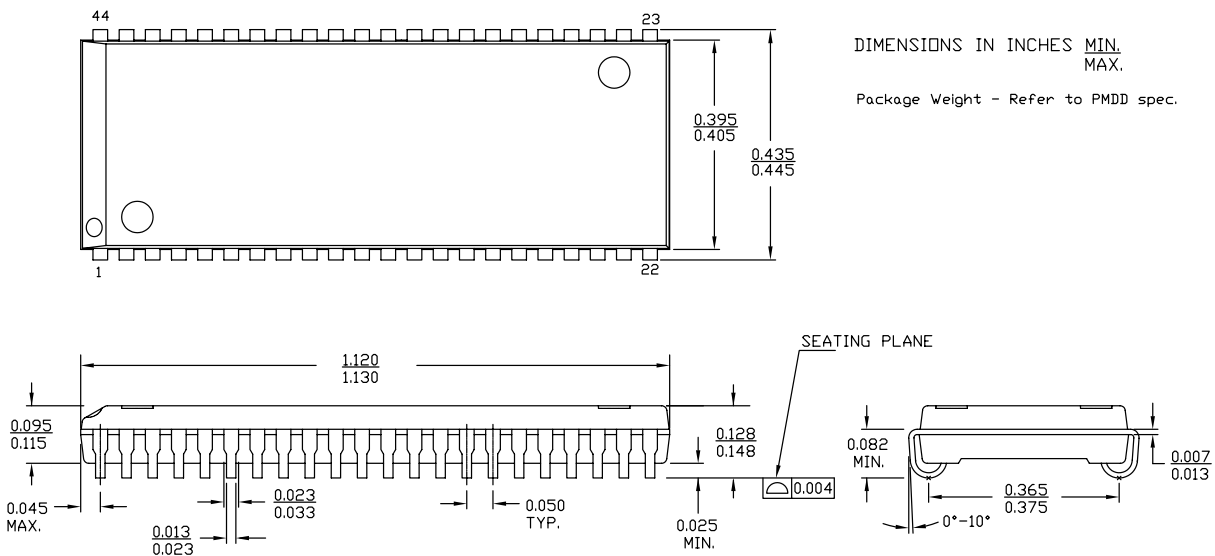

51-85082 *E



Package Diagrams (continued)

Figure 11. 48-ball FBGA (6 × 8 × 1 mm) BV48/BZ48 Package Outline, 51-85150

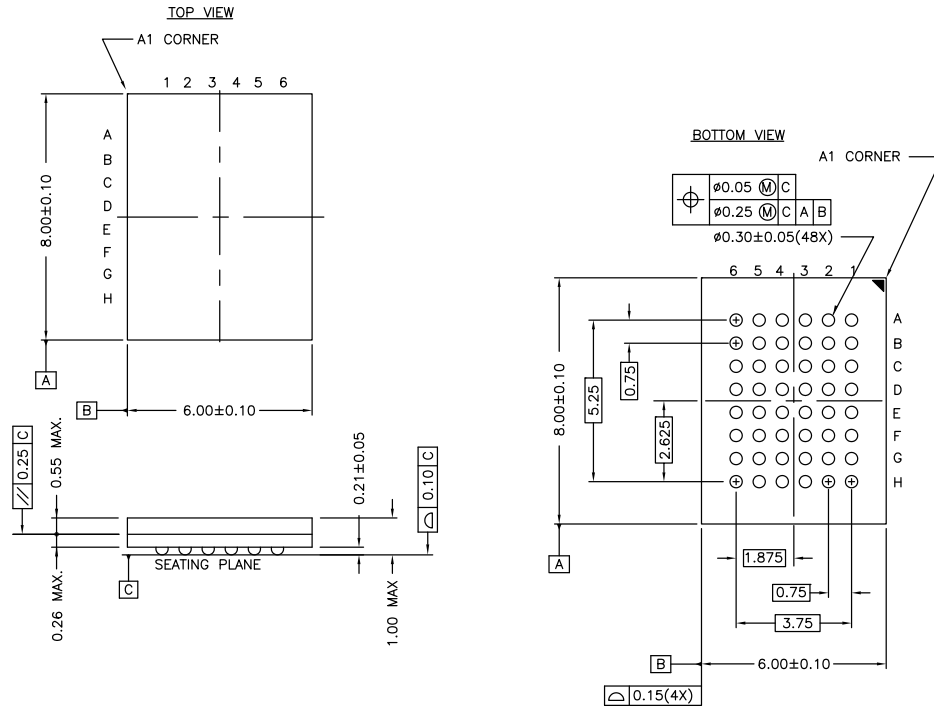

NOTE:
 PACKAGE WEIGHT: See Cypress Package Material Declaration Datasheet (PMDD) posted on the Cypress web.

51-85150 *H



Acronyms

Acronym	Description
CMOS	Complementary Metal Oxide Semiconductor
\overline{CE}	Chip Enable
FBGA	Fine-Pitch Ball Grid Array
I/O	Input/Output
\overline{OE}	Output Enable
SOJ	Small Outline J-lead
SRAM	Static Random Access Memory
TSOP	Thin Small-Outline Package
TTL	Transistor-Transistor Logic
\overline{WE}	Write Enable

Document Conventions

Units of Measure

Symbol	Unit of Measure
°C	degree Celsius
MHz	megahertz
μA	microampere
mA	milliampere
mm	millimeter
mW	milliwatt
ns	nanosecond
%	percent
pF	picofarad
V	volt
W	watt



Document History Page

Document Title: CY7C1021CV26, 1-Mbit (64 K × 16) Static RAM Document Number: 38-05589				
Rev.	ECN No.	Issue Date	Orig. of Change	Description of Change
**	238454	See ECN	RKF	New data sheet for Automotive.
*A	335861	See ECN	SYT	Added 44-pin SOJ Package related information in all instances across the document. Updated Ordering Information : Updated part numbers (Added Lead-Free Product Information).
*B	493543	See ECN	NXR	Updated Electrical Characteristics : Changed description of I _{IX} parameter from "Input Load Current" to "Input Leakage Current". Removed I _{OS} parameter and its details. Updated Ordering Information : Updated part numbers.
*C	2897087	03/22/10	AJU	Updated Ordering Information : Removed obsolete parts. Updated Package Diagrams .
*D	3057593	10/13/2010	PRAS	Updated Ordering Information : Updated part numbers. Added Ordering Code Definitions . Updated Package Diagrams .
*E	3098812	12/01/2010	PRAS	Minor edits across the document. Added Acronyms and Units of Measure . Updated to new template.
*F	3277371	06/08/2011	AJU	Updated Pin Configurations (Included pin configurations for 44-pin SOJ and 48-ball FBGA packages).
*G	4141238	09/30/2013	VINI	Updated Package Diagrams : spec 51-85087 – Changed revision from *C to *E. spec 51-85082 – Changed revision from *C to *E. spec 51-85150 – Changed revision from *F to *H. Updated to new template. Completing Sunset Review.
*H	4567793	11/12/2014	VINI	Updated Functional Description : Added "For a complete list of related resources, click here ." at the end. Updated Switching Characteristics : Added Note 11 and referred the same note in "Write Cycle". Updated Switching Waveforms : Added Note 17 and referred the same note in Figure 8 . Completing Sunset Review.
*I	4573200	11/18/2014	VINI	Updated Ordering Information : Removed prune part numbers namely CY7C1021CV26-15VXE, CY7C1021CV26-15BAE, CY7C1021CV26-15BAET, and CY7C1021CV26-15VXET.
*J	5004033	11/05/2015	VINI	Updated to new template. Completing Sunset Review.



Sales, Solutions, and Legal Information

Worldwide Sales and Design Support

Cypress maintains a worldwide network of offices, solution centers, manufacturer's representatives, and distributors. To find the office closest to you, visit us at [Cypress Locations](#).

Products

Automotive	cypress.com/go/automotive
Clocks & Buffers	cypress.com/go/clocks
Interface	cypress.com/go/interface
Lighting & Power Control	cypress.com/go/powerpsoc
Memory	cypress.com/go/memory
PSoC	cypress.com/go/psoc
Touch Sensing	cypress.com/go/touch
USB Controllers	cypress.com/go/USB
Wireless/RF	cypress.com/go/wireless

PSoC® Solutions

psoc.cypress.com/solutions
 PSoC 1 | PSoC 3 | PSoC 4 | PSoC 5LP

Cypress Developer Community

[Community](#) | [Forums](#) | [Blogs](#) | [Video](#) | [Training](#)

Technical Support

cypress.com/go/support

© Cypress Semiconductor Corporation, 2004-2015. The information contained herein is subject to change without notice. Cypress Semiconductor Corporation assumes no responsibility for the use of any circuitry other than circuitry embodied in a Cypress product. Nor does it convey or imply any license under patent or other rights. Cypress products are not warranted nor intended to be used for medical, life support, life saving, critical control or safety applications, unless pursuant to an express written agreement with Cypress. Furthermore, Cypress does not authorize its products for use as critical components in life-support systems where a malfunction or failure may reasonably be expected to result in significant injury to the user. The inclusion of Cypress products in life-support systems application implies that the manufacturer assumes all risk of such use and in doing so indemnifies Cypress against all charges.

Any Source Code (software and/or firmware) is owned by Cypress Semiconductor Corporation (Cypress) and is protected by and subject to worldwide patent protection (United States and foreign), United States copyright laws and international treaty provisions. Cypress hereby grants to licensee a personal, non-exclusive, non-transferable license to copy, use, modify, create derivative works of, and compile the Cypress Source Code and derivative works for the sole purpose of creating custom software and or firmware in support of licensee product to be used only in conjunction with a Cypress integrated circuit as specified in the applicable agreement. Any reproduction, modification, translation, compilation, or representation of this Source Code except as specified above is prohibited without the express written permission of Cypress.

Disclaimer: CYPRESS MAKES NO WARRANTY OF ANY KIND, EXPRESS OR IMPLIED, WITH REGARD TO THIS MATERIAL, INCLUDING, BUT NOT LIMITED TO, THE IMPLIED WARRANTIES OF MERCHANTABILITY AND FITNESS FOR A PARTICULAR PURPOSE. Cypress reserves the right to make changes without further notice to the materials described herein. Cypress does not assume any liability arising out of the application or use of any product or circuit described herein. Cypress does not authorize its products for use as critical components in life-support systems where a malfunction or failure may reasonably be expected to result in significant injury to the user. The inclusion of Cypress' product in a life-support systems application implies that the manufacturer assumes all risk of such use and in doing so indemnifies Cypress against all charges.

Use may be limited by and subject to the applicable Cypress software license agreement.

OUR CERTIFICATE

DiGi provide top-quality products and perfect service for customer worldwide through standardization, technological innovation and continuous improvement. DiGi through third-party certification, we strictly control the quality of products and services. Welcome your RFQ to

Email: Info@DiGi-Electronics.com



Tel: +00 852-30501935

RFQ Email: Info@DiGi-Electronics.com

DiGi is a global authorized distributor of electronic components.