

# CY7C1041CV33-12BAXET Datasheet

[www.digi-electronics.com](http://www.digi-electronics.com)

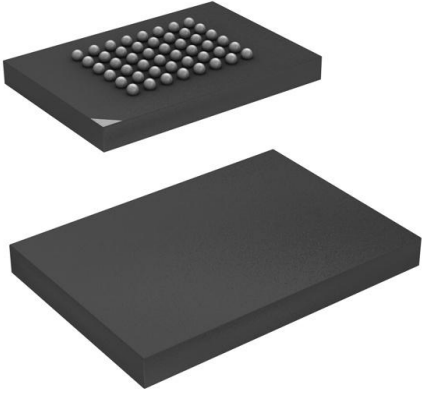

<https://www.DiGi-Electronics.com>

DiGi Electronics Part Number	CY7C1041CV33-12BAXET-DG
Manufacturer	<a href="#">Infineon Technologies</a>
Manufacturer Product Number	CY7C1041CV33-12BAXET
Description	IC SRAM 4MBIT PARALLEL 48FBGA
Detailed Description	SRAM - Asynchronous Memory IC 4Mbit Parallel 12 ns 48-FBGA (7x8.5)

This model CY7C1041CV33-12BAXET is available at DiGi Electronics.

DiGi Electronics offers a global database of semiconductor and electronic component datasheets.

We welcome your inquiries regarding pricing, lead time, or other product-related questions.

 [Request a Quote](#)

 [Datasheet Search](#)



Tel: +00 852-30501935

RFQ Email: [Info@DiGi-Electronics.com](mailto:Info@DiGi-Electronics.com)

DiGi is a global authorized distributor of electronic components.

## Purchase and inquiry

Manufacturer Product Number:

CY7C1041CV33-12BAXET

Series:

-

DiGi-Electronics Programmable:

Not Verified

Memory Format:

SRAM

Memory Size:

4Mbit

Memory Interface:

Parallel

Access Time:

12 ns

Operating Temperature:

-40°C ~ 125°C (TA)

Package / Case:

48-TFBGA

Base Product Number:

CY7C1041

Manufacturer:

Infineon Technologies

Product Status:

Discontinued at Digi-Key

Memory Type:

Volatile

Technology:

SRAM - Asynchronous

Memory Organization:

256K x 16

Write Cycle Time - Word, Page:

12ns

Voltage - Supply:

3V ~ 3.6V

Mounting Type:

Surface Mount

Supplier Device Package:

48-FBGA (7x8.5)

## Environmental & Export classification

RoHS Status:

ROHS3 Compliant

REACH Status:

REACH Unaffected

HTSUS:

8542.32.0041

Moisture Sensitivity Level (MSL):

3 (168 Hours)

ECCN:

3A991B2A



## CY7C1041CV33 Automotive

# 4-Mbit (256 K × 16) Static RAM

### Features

- Temperature ranges
  - Automotive-A: -40 °C to 85 °C
  - Automotive-E: -40 °C to 125 °C
- Pin and function compatible with CY7C1041BNV33
- High speed
  - $t_{AA}$  = 10 ns (Automotive-A)
  - $t_{AA}$  = 10 ns (Automotive-E)
- Low active power
  - 432 mW (max)
- Automatic power down when deselected
- TTL-compatible inputs and outputs
- Easy memory expansion with  $\overline{CE}$  and  $\overline{OE}$  features
- Available in Pb-free and non Pb-free 44-pin 400 Mil SOJ, 44-pin TSOP II and 48-ball FBGA packages

### Functional Description

The CY7C1041CV33 Automotive is a high performance CMOS static RAM organized as 262,144 words by 16 bits.

To write to the device, take Chip Enable ( $\overline{CE}$ ) and Write Enable ( $\overline{WE}$ ) inputs LOW. If Byte Low Enable ( $\overline{BLE}$ ) is LOW, then data from I/O pins ( $I/O_0$  through  $I/O_7$ ), is written into the location specified on the address pins ( $A_0$  through  $A_{17}$ ). If Byte High Enable ( $\overline{BHE}$ ) is LOW, then data from I/O pins ( $I/O_8$  through  $I/O_{15}$ ) is written into the location specified on the address pins ( $A_0$  through  $A_{17}$ ).

To read from the device, take Chip Enable ( $\overline{CE}$ ) and Output Enable ( $\overline{OE}$ ) LOW while forcing the Write Enable ( $\overline{WE}$ ) HIGH. If Byte Low Enable ( $\overline{BLE}$ ) is LOW, then data from the memory location specified by the address pins appear on  $I/O_0$  to  $I/O_7$ . If Byte High Enable ( $\overline{BHE}$ ) is LOW, then data from memory appears on  $I/O_8$  to  $I/O_{15}$ . For more information, see the [Truth Table on page 11](#) for a complete description of Read and Write modes.

The input and output pins ( $I/O_0$  through  $I/O_{15}$ ) are placed in a high impedance state when the device is deselected ( $\overline{CE}$  HIGH), the outputs are disabled ( $\overline{OE}$  HIGH), the  $\overline{BHE}$  and  $\overline{BLE}$  are disabled ( $\overline{BHE}$ ,  $\overline{BLE}$  HIGH), or during a write operation ( $\overline{CE}$  LOW and  $\overline{WE}$  LOW).

### Logic Block Diagram

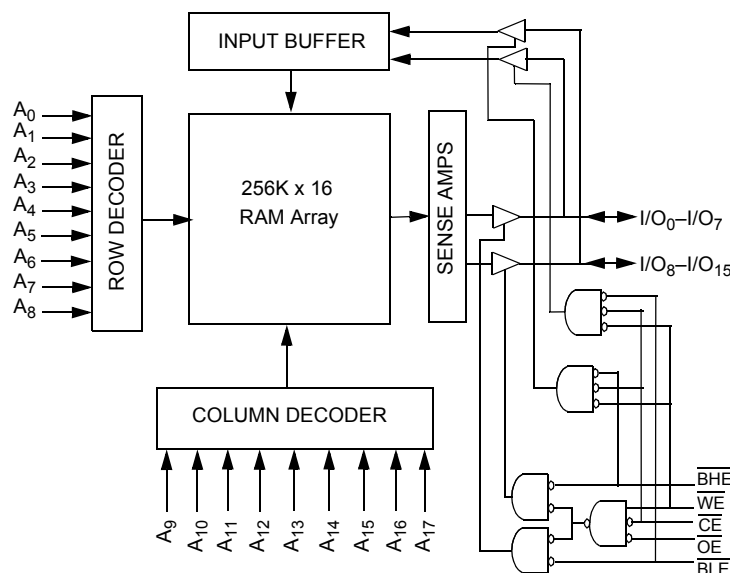



## Contents

<b>Selection Guide</b> .....	<b>3</b>	<b>Package Diagrams</b> .....	<b>13</b>
<b>Pin Configuration</b> .....	<b>3</b>	<b>Acronyms</b> .....	<b>16</b>
<b>Pin Definitions</b> .....	<b>4</b>	<b>Document Conventions</b> .....	<b>16</b>
<b>Maximum Ratings</b> .....	<b>5</b>	Units of Measure .....	16
<b>Operating Range</b> .....	<b>5</b>	<b>Document History Page</b> .....	<b>17</b>
<b>Electrical Characteristics</b> .....	<b>5</b>	<b>Sales, Solutions, and Legal Information</b> .....	<b>18</b>
<b>Capacitance</b> .....	<b>6</b>	Worldwide Sales and Design Support .....	18
<b>Thermal Resistance</b> .....	<b>6</b>	Products .....	18
<b>AC Test Loads and Waveforms</b> .....	<b>6</b>	PSoC® Solutions .....	18
<b>Switching Characteristics</b> .....	<b>7</b>	Cypress Developer Community .....	18
<b>Switching Waveforms</b> .....	<b>8</b>	Technical Support .....	18
<b>Truth Table</b> .....	<b>11</b>		
<b>Ordering Information</b> .....	<b>12</b>		
Ordering Code Definitions .....	12		



## CY7C1041CV33 Automotive

### Selection Guide

Description		-10	-12	-20	Unit
Maximum Access Time		10	12	20	ns
Maximum Operating Current	Automotive-A	100	–	85	mA
	Automotive-E	130	120	90	mA
Maximum CMOS Standby Current	Automotive-A	10	–	10	mA
	Automotive-E	15	15	15	mA

### Pin Configuration

Figure 1. 44-pin SOJ/TSOP II pinout (Top View) <sup>[1]</sup>

A <sub>0</sub>	1	44	A <sub>17</sub>
A <sub>1</sub>	2	43	A <sub>16</sub>
A <sub>2</sub>	3	42	A <sub>15</sub>
A <sub>3</sub>	4	41	OE
A <sub>4</sub>	5	40	BHE
CE	6	39	BLE
IO <sub>0</sub>	7	38	IO <sub>15</sub>
IO <sub>1</sub>	8	37	IO <sub>14</sub>
IO <sub>2</sub>	9	36	IO <sub>13</sub>
IO <sub>3</sub>	10	35	IO <sub>12</sub>
V <sub>CC</sub>	11	34	V <sub>SS</sub>
V <sub>SS</sub>	12	33	V <sub>CC</sub>
IO <sub>4</sub>	13	32	IO <sub>11</sub>
IO <sub>5</sub>	14	31	IO <sub>10</sub>
IO <sub>6</sub>	15	30	IO <sub>9</sub>
IO <sub>7</sub>	16	29	IO <sub>8</sub>
WE	17	28	NC
A <sub>5</sub>	18	27	A <sub>14</sub>
A <sub>6</sub>	19	26	A <sub>13</sub>
A <sub>7</sub>	20	25	A <sub>12</sub>
A <sub>8</sub>	21	24	A <sub>11</sub>
A <sub>9</sub>	22	23	A <sub>10</sub>

Figure 2. 48-ball FBGA pinout (Top View) <sup>[1]</sup>

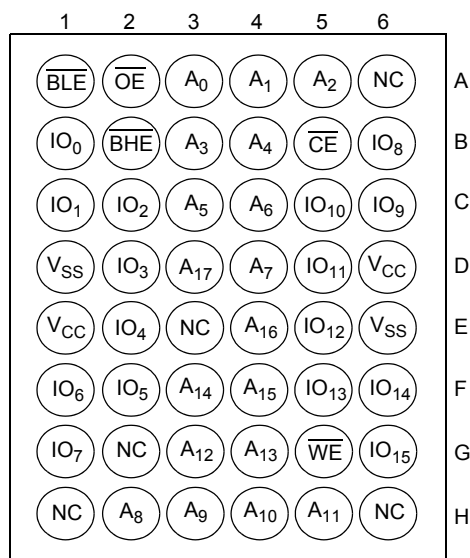

#### Note

1. NC pins are not connected on the die.



## Pin Definitions

Pin Name	SOJ, TSOP Pin Number	BGA Pin Number	I/O Type	Description
A <sub>0</sub> -A <sub>17</sub>	1-5, 18-27, 42-44	A3, A4, A5, B3, B4, C3, C4, D4, H2, H3, H4, H5, G3, G4, F3, F4, E4, D3	Input	<b>Address Inputs.</b> Used to select one of the address locations.
I/O <sub>0</sub> -I/O <sub>15</sub>	7-10, 13-16, 29-32, 35-38	B1, C1, C2, D2, E2, F2, F1, G1, B6, C6, C5, D5, E5, F5, F6, G6	Input or Output	<b>Bidirectional Data I/O lines.</b> Used as input or output lines depending on operation.
NC	28	A6, E3, G2, H1, H6	No Connect	<b>No Connects.</b> Not connected to the die.
$\overline{\text{WE}}$	17	G5	Input or Control	<b>Write Enable Input, Active LOW.</b> When selected LOW, a write is conducted. When deselected HIGH, a read is conducted.
$\overline{\text{CE}}$	6	B5	Input or Control	<b>Chip Enable Input, Active LOW.</b> When LOW, selects the chip. When HIGH, deselects the chip.
$\overline{\text{BHE}}, \overline{\text{BLE}}$	40, 39	B2, A1	Input or Control	<b>Byte Write Select Inputs, Active LOW.</b> $\overline{\text{BHE}}$ controls I/O <sub>15</sub> -I/O <sub>8</sub> , $\overline{\text{BLE}}$ controls I/O <sub>7</sub> -I/O <sub>0</sub> .
$\overline{\text{OE}}$	41	A2	Input or Control	<b>Output Enable, Active LOW.</b> Controls the direction of the I/O pins. When LOW, the I/O pins are allowed to behave as outputs. When deasserted HIGH, the I/O pins are tri-stated and act as input data pins.
V <sub>SS</sub>	12, 34	D1, E6	Ground	<b>Ground for the Device.</b> Connected to ground of the system.
V <sub>CC</sub>	11, 33	D6, E1	Power Supply	<b>Power Supply Inputs to the Device.</b>



## CY7C1041CV33 Automotive

### Maximum Ratings

Exceeding maximum ratings may impair the useful life of the device. These user guidelines are not tested.

Storage Temperature ..... -65 °C to +150 °C

Ambient Temperature with  
Power Applied ..... -55 °C to +125 °C

Supply Voltage on  
 $V_{CC}$  Relative to GND <sup>[2]</sup> ..... -0.5 V to +4.6 V

DC Voltage Applied to Outputs  
in High Z State <sup>[2]</sup> ..... -0.5 V to  $V_{CC} + 0.5$  V

DC Input Voltage <sup>[2]</sup> ..... -0.5 V to  $V_{CC} + 0.5$  V

Current into Outputs (LOW) ..... 20 mA

Static Discharge Voltage  
(MIL-STD-883, Method 3015) ..... > 2001 V

Latch Up Current ..... > 200 mA

### Operating Range

Range	Ambient Temperature ( $T_A$ )	$V_{CC}$
Automotive-A	-40 °C to +85 °C	3.3 V ± 10%
Automotive-E	-40 °C to +125 °C	

### Electrical Characteristics

Over the Operating Range

Parameter	Description	Test Conditions	-10		-12		-20		Unit	
			Min	Max	Min	Max	Min	Max		
$V_{OH}$	Output HIGH Voltage	$V_{CC} = \text{Min}, I_{OH} = -4.0 \text{ mA}$	2.4	-	2.4	-	2.4	-	V	
$V_{OL}$	Output LOW Voltage	$V_{CC} = \text{Min}, I_{OL} = 8.0 \text{ mA}$	-	0.4	-	0.4	-	0.4	V	
$V_{IH}$	Input HIGH Voltage		2.0	$V_{CC} + 0.3$	2.0	$V_{CC} + 0.3$	2.0	$V_{CC} + 0.3$	V	
$V_{IL}$ <sup>[2]</sup>	Input LOW Voltage		-0.3	0.8	-0.3	0.8	-0.3	0.8	V	
$I_{IX}$	Input Leakage Current	$GND \leq V_I \leq V_{CC}$	Auto-A	-1	+1	-	-	-1	+1	$\mu\text{A}$
			Auto-E	-20	+20	-20	+20	-20	+20	
$I_{OZ}$	Output Leakage Current	$GND \leq V_{OUT} \leq V_{CC}$ , Output disabled	Auto-A	-1	+1	-	-	-1	+1	$\mu\text{A}$
			Auto-E	-20	+20	-20	+20	-20	+20	
$I_{CC}$	$V_{CC}$ Operating Supply Current	$V_{CC} = \text{Max}$ , $f = f_{MAX} = 1/t_{RC}$	Auto-A	-	100	-	-	-	85	mA
			Auto-E	-	130	-	120	-	90	
$I_{SB1}$	Automatic CE Power Down Current – TTL Inputs	Max $V_{CC}$ , $\overline{CE} \geq V_{IH}$ , $V_{IN} \geq V_{IH}$ , or $V_{IN} \leq V_{IL}$ , $f = f_{MAX}$	Auto-A	-	40	-	-	-	40	mA
			Auto-E	-	45	-	45	-	45	
$I_{SB2}$	Automatic CE Power Down Current – CMOS Inputs	Max $V_{CC}$ , $CE \geq V_{CC} - 0.3 \text{ V}$ , $V_{IN} \geq V_{CC} - 0.3 \text{ V}$ , or $V_{IN} \leq 0.3 \text{ V}$ , $f = 0$	Auto-A	-	10	-	-	-	10	mA
			Auto-E	-	15	-	15	-	15	

#### Note

2.  $V_{IL(\text{min})} = -2.0 \text{ V}$  and  $V_{IH(\text{max})} = V_{CC} + 0.5 \text{ V}$  for pulse durations of less than 20 ns.



## Capacitance

Parameter <sup>[3]</sup>	Description	Test Conditions	Max	Unit
$C_{IN}$	Input Capacitance	$T_A = 25\text{ }^\circ\text{C}$ , $f = 1\text{ MHz}$ , $V_{CC} = 3.3\text{ V}$	8	pF
$C_{OUT}$	Output Capacitance		8	pF

## Thermal Resistance

Parameter <sup>[3]</sup>	Description	Test Conditions	44-pin SOJ	44-pin TSOP II	48-ball FBGA	Unit
$\Theta_{JA}$	Thermal resistance (junction to ambient)	Test conditions follow standard test methods and procedures for measuring thermal impedance, per EIA/JESD51	25.99	42.96	38.15	$^\circ\text{C/W}$
$\Theta_{JC}$	Thermal resistance (junction to case)		18.8	10.75	9.15	$^\circ\text{C/W}$

## AC Test Loads and Waveforms

Figure 3. AC Test Loads and Waveforms <sup>[4]</sup>

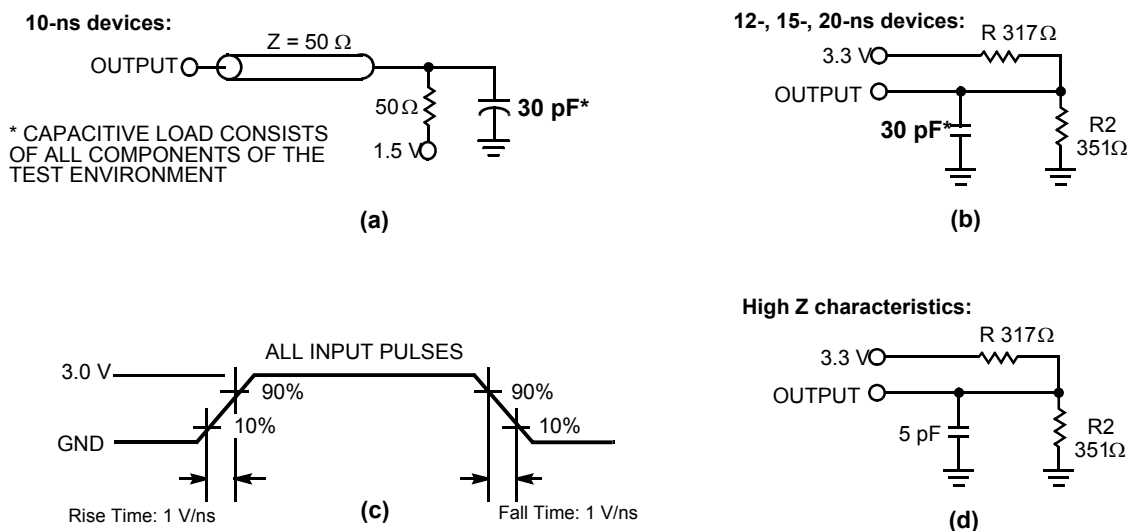

### Notes

- Tested initially and after any design or process changes that may affect these parameters.
- AC characteristics (except High Z) for 10 ns parts are tested using the load conditions shown in Figure 3 (a). All other speeds are tested using the Thevenin load shown in Figure 3 (b). High Z characteristics are tested for all speeds using the test load shown in Figure 3 (d).



## Switching Characteristics

Over the Operating Range

Parameter <sup>[5]</sup>	Description	-10		-12		-20		Unit	
		Min	Max	Min	Max	Min	Max		
<b>Read Cycle</b>									
$t_{power}^{[6]}$	$V_{CC}$ (Typical) to the First Access	100	–	100	–	100	–	$\mu$ s	
$t_{RC}$	Read Cycle Time	10	–	12	–	20	–	ns	
$t_{AA}$	Address to Data Valid	–	10	–	12	–	20	ns	
$t_{OHA}$	Data Hold from Address Change	3	–	3	–	3	–	ns	
$t_{ACE}$	$\overline{CE}$ LOW to Data Valid	–	10	–	12	–	20	ns	
$t_{DOE}$	$\overline{OE}$ LOW to Data Valid	Auto-A	–	5	–	6	–	8	ns
		Auto-E	–	6	–	7	–	8	
$t_{LZOE}$	$\overline{OE}$ LOW to Low Z <sup>[7]</sup>	0	–	0	–	0	–	ns	
$t_{HZOE}$	$\overline{OE}$ HIGH to High Z <sup>[7, 8]</sup>	–	5	–	6	–	8	ns	
$t_{LZCE}$	$\overline{CE}$ LOW to Low Z <sup>[7]</sup>	3	–	3	–	3	–	ns	
$t_{HZCE}$	$\overline{CE}$ HIGH to High Z <sup>[7, 8]</sup>	–	5	–	6	–	8	ns	
$t_{PU}$	$\overline{CE}$ LOW to Power Up	0	–	0	–	0	–	ns	
$t_{PD}$	$\overline{CE}$ HIGH to Power Down	–	10	–	12	–	20	ns	
$t_{DBE}$	Byte Enable to Data Valid	Auto-A	–	5	–	6	–	8	ns
		Auto-E	–	6	–	7	–	8	
$t_{LZBE}$	Byte Enable to Low Z	0	–	0	–	0	–	ns	
$t_{HZBE}$	Byte Disable to High Z	–	6	–	6	–	8	ns	
<b>Write Cycle <sup>[9, 10]</sup></b>									
$t_{WC}$	Write Cycle Time	10	–	12	–	20	–	ns	
$t_{SCE}$	$\overline{CE}$ LOW to Write End	7	–	8	–	10	–	ns	
$t_{AW}$	Address Setup to Write End	7	–	8	–	10	–	ns	
$t_{HA}$	Address Hold from Write End	0	–	0	–	0	–	ns	
$t_{SA}$	Address Setup to Write Start	0	–	0	–	0	–	ns	
$t_{PWE}$	$\overline{WE}$ Pulse Width	7	–	8	–	10	–	ns	
$t_{SD}$	Data Setup to Write End	5	–	6	–	8	–	ns	
$t_{HD}$	Data Hold from Write End	0	–	0	–	0	–	ns	
$t_{LZWE}$	$\overline{WE}$ HIGH to Low Z <sup>[7]</sup>	3	–	3	–	3	–	ns	
$t_{HZWE}$	$\overline{WE}$ LOW to High Z <sup>[7, 8]</sup>	–	5	–	6	–	8	ns	
$t_{BW}$	Byte Enable to End of Write	7	–	8	–	10	–	ns	

### Notes

- Test conditions assume signal transition time of 3 ns or less, timing reference levels of 1.5 V, and input pulse levels of 0 to 3.0 V.
- $t_{POWER}$  gives the minimum amount of time that the power supply is at typical  $V_{CC}$  values until the first memory access is performed.
- At any temperature and voltage condition,  $t_{HZCE}$  is less than  $t_{LZCE}$ ,  $t_{HZBE}$  is less than  $t_{LZBE}$ ,  $t_{HZOE}$  is less than  $t_{LZOE}$ , and  $t_{HZWE}$  is less than  $t_{LZWE}$  for any device.
- $t_{HZOE}$ ,  $t_{HZCE}$ ,  $t_{HZBE}$ , and  $t_{HZWE}$  are specified with a load capacitance of 5 pF as in part (d) of [Figure 3 on page 6](#). Transition is measured  $\pm 500$  mV from steady state voltage.
- The internal write time of the memory is defined by the overlap of  $\overline{CE}$  LOW,  $\overline{WE}$  LOW, and  $\overline{BHE}/\overline{BLE}$  LOW.  $\overline{CE}$ ,  $\overline{WE}$ , and  $\overline{BHE}/\overline{BLE}$  must be LOW to initiate a write. The transition of these signals terminate the write. The input data setup and hold timing is referenced to the leading edge of the signal that terminates the write.
- The minimum Write cycle time for Write Cycle No. 3 ( $\overline{WE}$  controlled,  $\overline{OE}$  LOW) is the sum of  $t_{HZWE}$  and  $t_{SD}$ .



## Switching Waveforms

Figure 4. Read Cycle No. 1 (Address Transition Controlled) [11, 12]

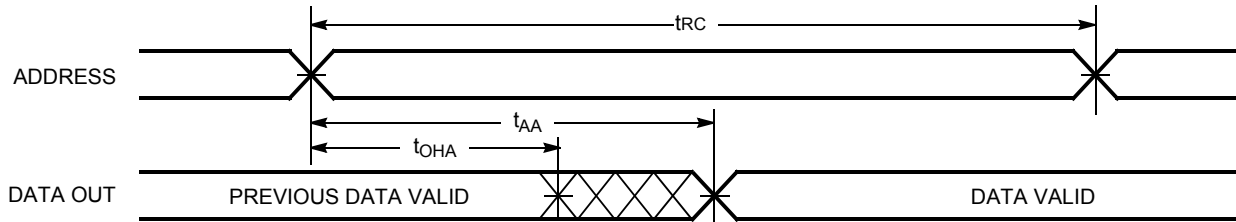
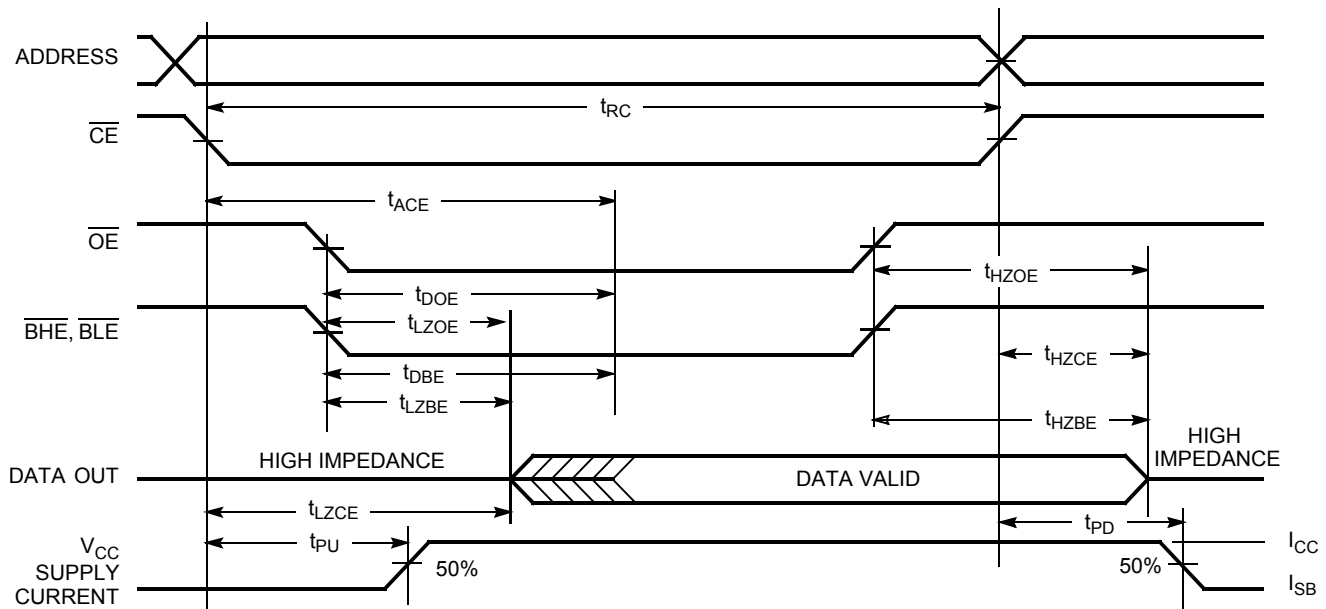

Figure 5. Read Cycle No. 2 ( $\overline{\text{OE}}$  Controlled) [12, 13]



### Notes

11. Device is continuously selected.  $\overline{\text{OE}}$ ,  $\overline{\text{CE}}$ ,  $\overline{\text{BHE}}$ , and/or  $\overline{\text{BLE}} = V_{\text{IL}}$ .
12. WE is HIGH for read cycle.
13. Address valid prior to or coincident with  $\overline{\text{CE}}$  transition LOW.

## Switching Waveforms (continued)

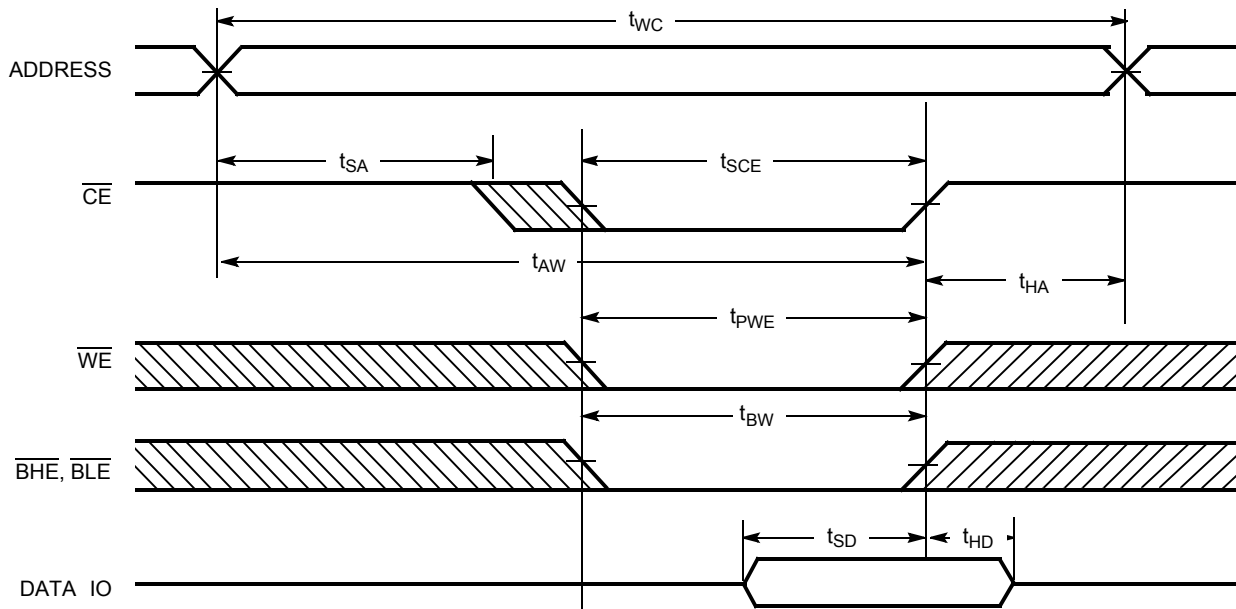
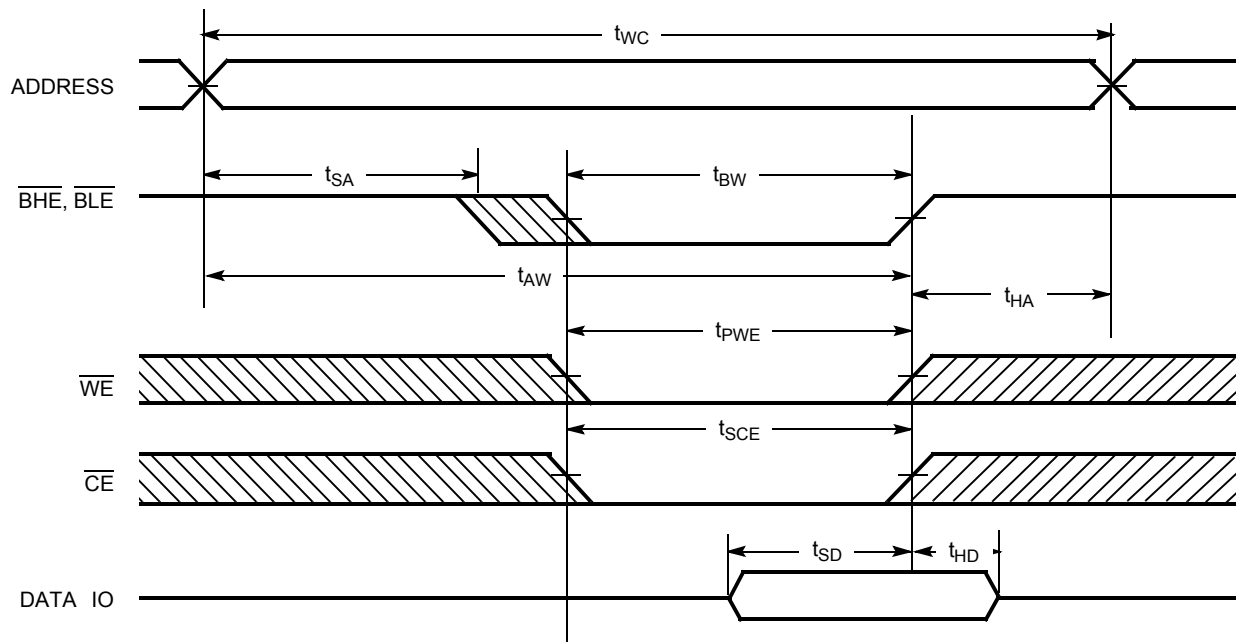
Figure 6. Write Cycle No. 1 ( $\overline{\text{CE}}$  Controlled) [14, 15]Figure 7. Write Cycle No. 2 ( $\overline{\text{BLE}}$  or  $\overline{\text{BHE}}$  Controlled)

## Notes

14. Data IO is high impedance if  $\overline{\text{OE}}$ ,  $\overline{\text{BHE}}$ , and/or  $\overline{\text{BLE}} = V_{IH}$ .15. If  $\overline{\text{CE}}$  goes HIGH simultaneously with  $\overline{\text{WE}}$  going HIGH, the output remains in a high impedance state.

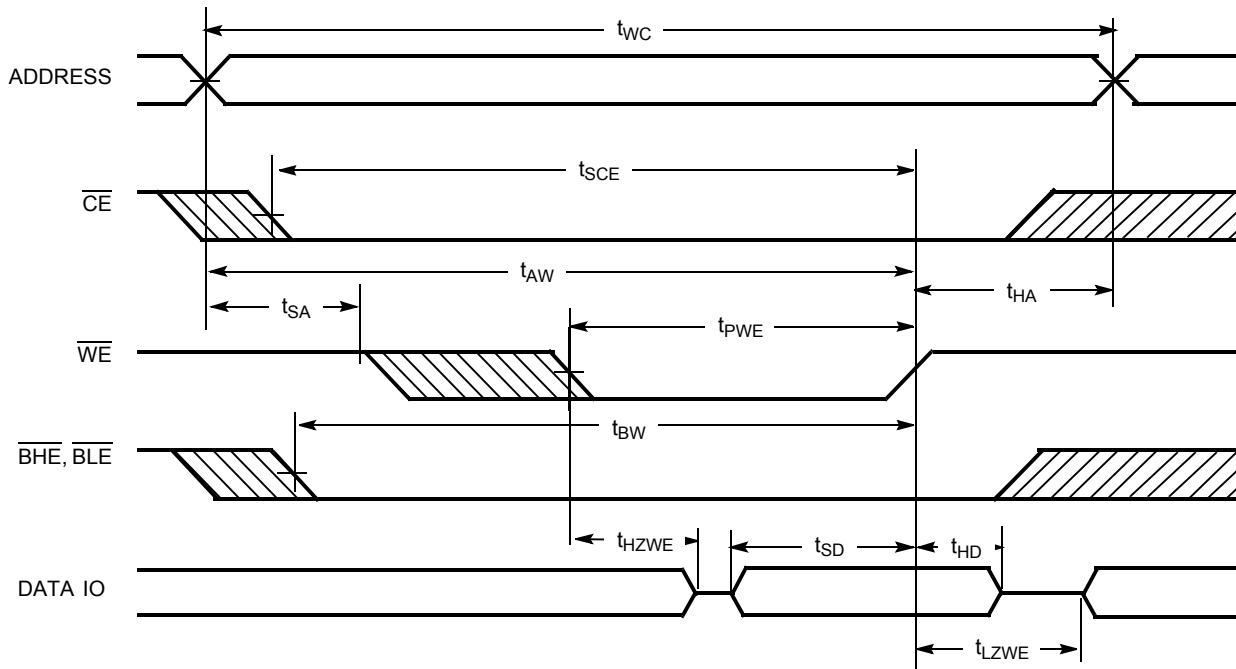
**Switching Waveforms** (continued)**Figure 8. Write Cycle No. 3 ( $\overline{\text{WE}}$  Controlled,  $\overline{\text{OE}}$  LOW)**



### Truth Table

$\overline{CE}$	$\overline{OE}$	$\overline{WE}$	$\overline{BLE}$	$\overline{BHE}$	I/O <sub>0</sub> -I/O <sub>7</sub>	I/O <sub>8</sub> -I/O <sub>15</sub>	Mode	Power
H	X	X	X	X	High Z	High Z	Power Down	Standby (I <sub>SB</sub> )
L	L	H	L	L	Data Out	Data Out	Read – All Bits	Active (I <sub>CC</sub> )
			L	H	Data Out	High Z	Read – Lower Bits Only	Active (I <sub>CC</sub> )
			H	L	High Z	Data Out	Read – Upper Bits Only	Active (I <sub>CC</sub> )
L	X	L	L	L	Data In	Data In	Write – All Bits	Active (I <sub>CC</sub> )
			L	H	Data In	High Z	Write – Lower Bits Only	Active (I <sub>CC</sub> )
			H	L	High Z	Data In	Write – Upper Bits Only	Active (I <sub>CC</sub> )
L	H	H	X	X	High Z	High Z	Selected, Outputs Disabled	Active (I <sub>CC</sub> )
L	X	X	H	H	High Z	High Z	Selected, Outputs Disabled	Active (I <sub>CC</sub> )



## CY7C1041CV33 Automotive

### Ordering Information

Cypress offers other versions of this type of product in many different configurations and features. The below table contains only the list of parts that are currently available. For a complete listing of all options, visit the Cypress website at [www.cypress.com](http://www.cypress.com) and refer to the product summary page at <http://www.cypress.com/products> or contact your local sales representative.

Cypress maintains a worldwide network of offices, solution centers, manufacturer's representatives and distributors. To find the office closest to you, visit us at <http://www.cypress.com/go/datasheet/offices>.

Speed (ns)	Ordering Code	Package Diagram	Package Type	Operating Range
10	CY7C1041CV33-10BAXA	51-85106	48-ball FBGA (Pb-free)	Automotive-A
	CY7C1041CV33-10ZSXA	51-85087	44-pin TSOP II (Pb-free)	
	CY7C1041CV33-10BAXE	51-85106	48-ball FBGA (Pb-free)	Automotive-E
12	CY7C1041CV33-12BAXE	51-85106	48-ball FBGA (Pb-free)	Automotive-E
	CY7C1041CV33-12ZSXE	51-85087	44-pin TSOP II (Pb-free)	
20	CY7C1041CV33-20ZSXA	51-85087	44-pin TSOP II (Pb-free)	Automotive-A
	CY7C1041CV33-20VXE		44-pin (400-mil) Molded SOJ (Pb-free)	Automotive-E
	CY7C1041CV33-20ZSXE		44-pin TSOP II (Pb-free)	

Please contact your local Cypress sales representative for availability of these parts

### Ordering Code Definitions

CY 7 C 1 04 1 C V33 - XX XX X X

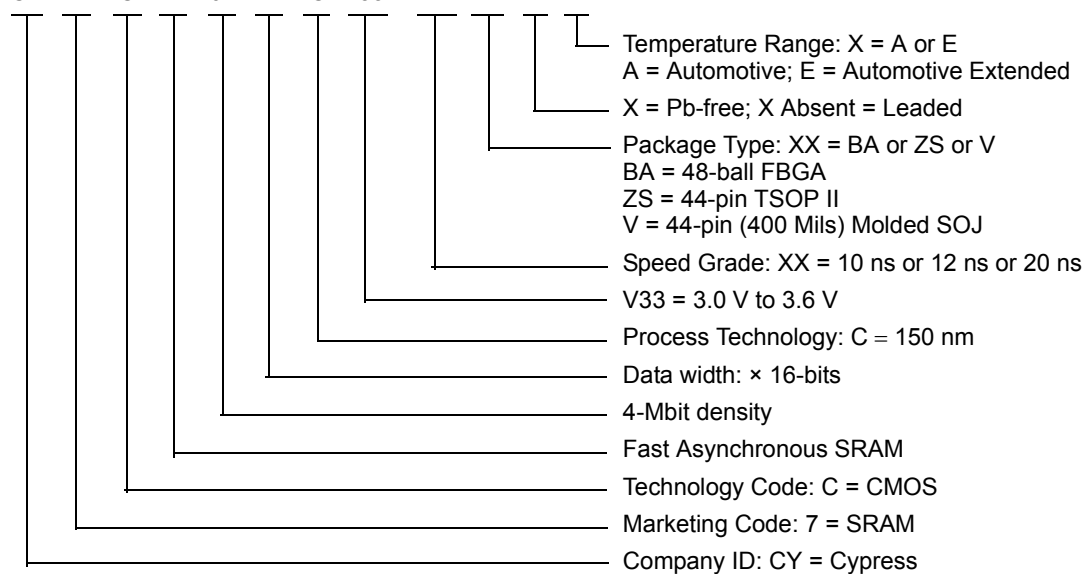



# CY7C1041CV33 Automotive

## Package Diagrams

Figure 9. 44-pin SOJ 400 Mils V44.4 Package Outline, 51-85082

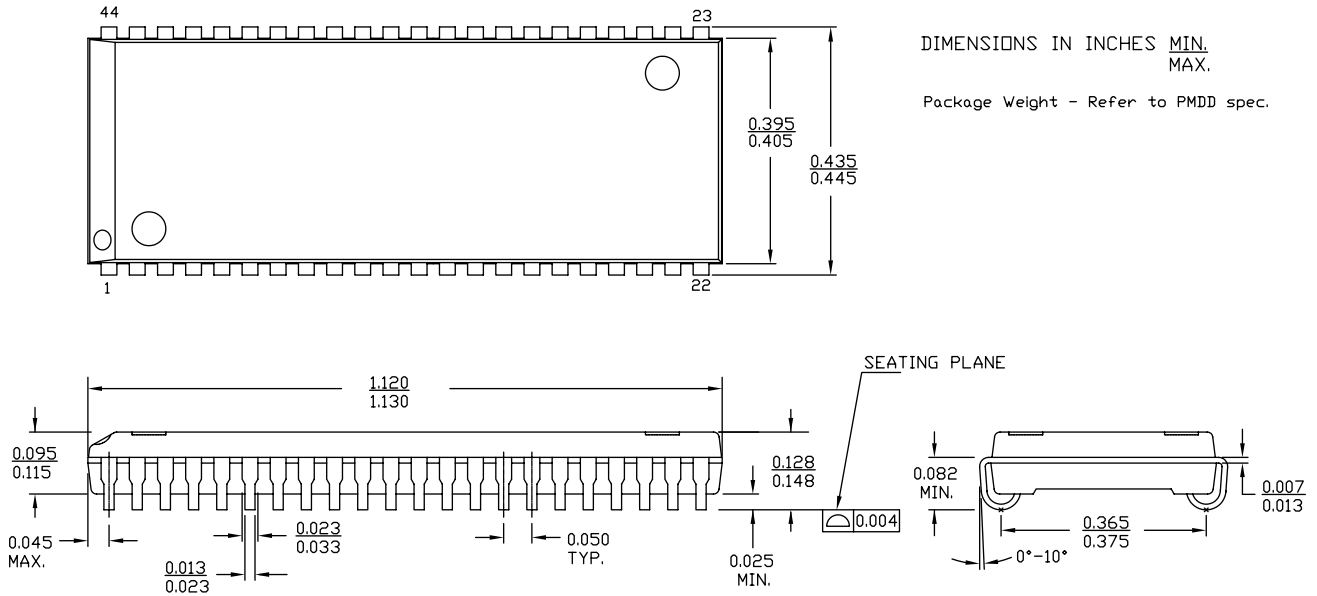

51-85082 \*E



**CY7C1041CV33 Automotive**

**Package Diagrams** (continued)

**Figure 10. 44-pin TSOP Z44-II Package Outline, 51-85087**

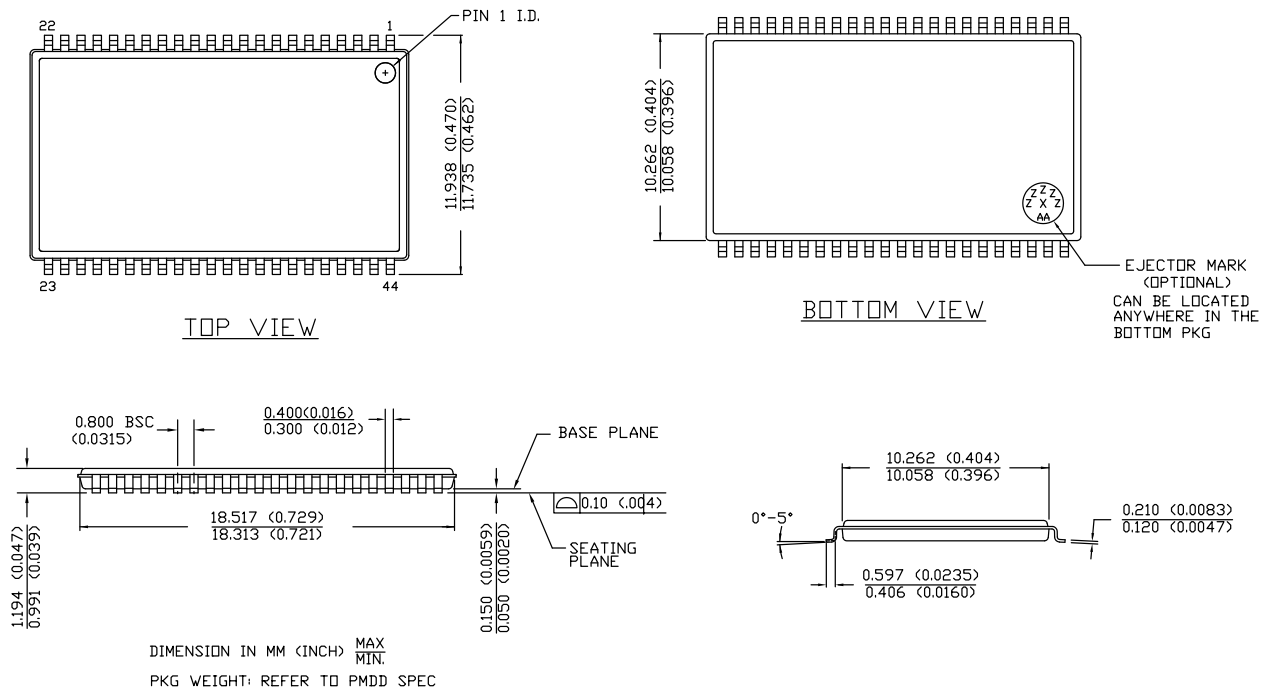

51-85087 \*E



# CY7C1041CV33 Automotive

## Package Diagrams (continued)

Figure 11. 48-ball FBGA (7.0 × 8.5 × 1.2 mm) BA48A Package Outline, 51-85106

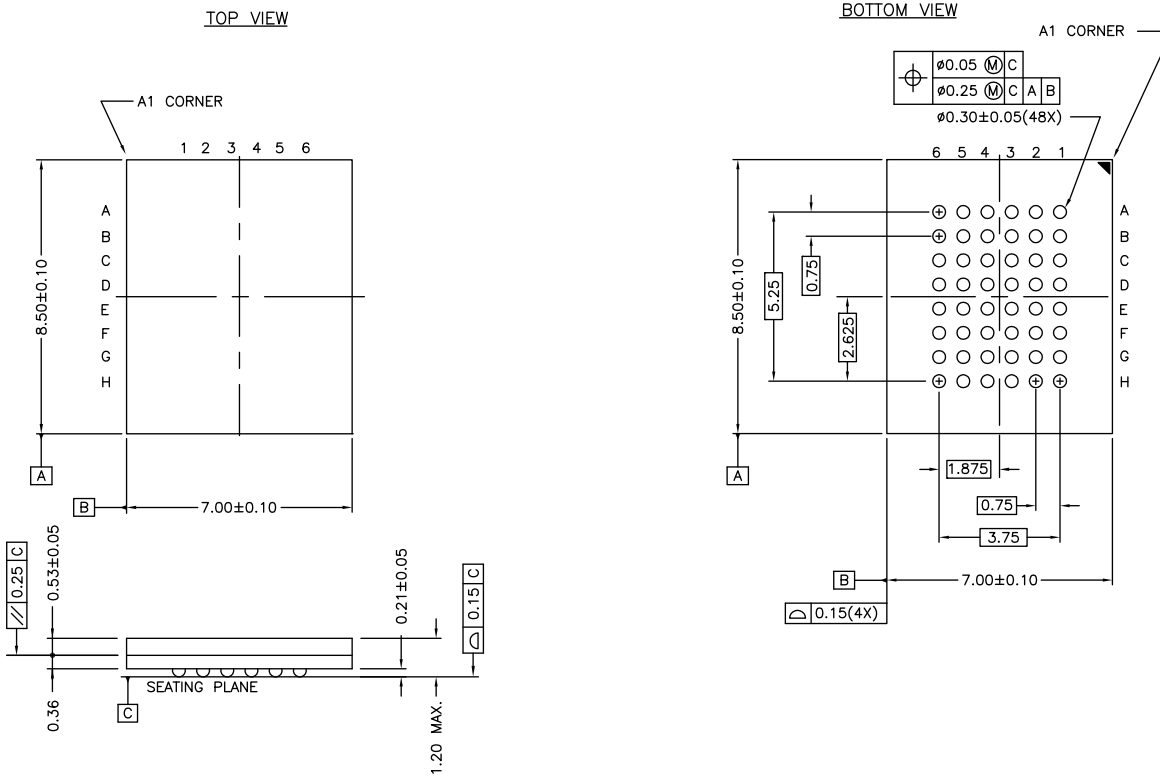

51-85106 \*G



## Acronyms

Acronym	Description
$\overline{CE}$	Chip Enable
CMOS	Complementary Metal Oxide Semiconductor
FBGA	Fine-Pitch Ball Grid Array
I/O	Input/Output
$\overline{OE}$	Output Enable
SOJ	Small Outline J-lead
SRAM	Static Random Access Memory
TSOP	Thin Small Outline Package
TTL	Transistor-Transistor Logic
$\overline{WE}$	Write Enable

## Document Conventions

### Units of Measure

Symbol	Unit of Measure
$^{\circ}\text{C}$	degree Celsius
MHz	megahertz
$\mu\text{A}$	microampere
$\mu\text{s}$	microsecond
mA	milliampere
mm	millimeter
ms	millisecond
mW	milliwatt
ns	nanosecond
$\Omega$	ohm
%	percent
pF	picofarad
V	volt
W	watt



## Document History Page

Document Title: CY7C1041CV33 Automotive, 4-Mbit (256 K × 16) Static RAM Document Number: 001-67307				
Rev.	ECN No.	Issue Date	Orig. of Change	Description of Change
**	3187164	03/03/2011	PRAS	Separation of the automotive datasheet from CY7C1041CV33 spec no. 38-05134 Rev. *K. Further rev of 38-05134 would include only industrial / commercial parts.
*A	3265070	05/24/2011	PRAS	Updated <a href="#">Functional Description</a> (Removed "For best practice recommendations, refer to the Cypress application note AN1064, SRAM System Guidelines.").
*B	3507652	01/24/2012	TAVA	Updated <a href="#">Features</a> . Updated <a href="#">Selection Guide</a> . Updated <a href="#">Electrical Characteristics</a> . Updated <a href="#">Switching Characteristics</a> . Updated <a href="#">Ordering Information</a> . Updated <a href="#">Package Diagrams</a> .
*C	4318563	03/24/2014	VINI	Updated <a href="#">Package Diagrams</a> : spec 51-85082 – Changed revision from *D to *E. spec 51-85087 – Changed revision from *D to *E.  Updated in new template.  Completing Sunset Review.



## Sales, Solutions, and Legal Information

### Worldwide Sales and Design Support

Cypress maintains a worldwide network of offices, solution centers, manufacturer's representatives, and distributors. To find the office closest to you, visit us at [Cypress Locations](#).

#### Products

Automotive	<a href="http://cypress.com/go/automotive">cypress.com/go/automotive</a>
Clocks & Buffers	<a href="http://cypress.com/go/clocks">cypress.com/go/clocks</a>
Interface	<a href="http://cypress.com/go/interface">cypress.com/go/interface</a>
Lighting & Power Control	<a href="http://cypress.com/go/powerpsoc">cypress.com/go/powerpsoc</a> <a href="http://cypress.com/go/plc">cypress.com/go/plc</a>
Memory	<a href="http://cypress.com/go/memory">cypress.com/go/memory</a>
PSoC	<a href="http://cypress.com/go/psoc">cypress.com/go/psoc</a>
Touch Sensing	<a href="http://cypress.com/go/touch">cypress.com/go/touch</a>
USB Controllers	<a href="http://cypress.com/go/USB">cypress.com/go/USB</a>
Wireless/RF	<a href="http://cypress.com/go/wireless">cypress.com/go/wireless</a>

#### PSoC<sup>®</sup> Solutions

[psoc.cypress.com/solutions](http://psoc.cypress.com/solutions)  
PSoC 1 | PSoC 3 | PSoC 4 | PSoC 5LP

#### Cypress Developer Community

[Community](#) | [Forums](#) | [Blogs](#) | [Video](#) | [Training](#)

#### Technical Support

[cypress.com/go/support](http://cypress.com/go/support)

© Cypress Semiconductor Corporation, 2011-2014. The information contained herein is subject to change without notice. Cypress Semiconductor Corporation assumes no responsibility for the use of any circuitry other than circuitry embodied in a Cypress product. Nor does it convey or imply any license under patent or other rights. Cypress products are not warranted nor intended to be used for medical, life support, life saving, critical control or safety applications, unless pursuant to an express written agreement with Cypress. Furthermore, Cypress does not authorize its products for use as critical components in life-support systems where a malfunction or failure may reasonably be expected to result in significant injury to the user. The inclusion of Cypress products in life-support systems application implies that the manufacturer assumes all risk of such use and in doing so indemnifies Cypress against all charges.

Any Source Code (software and/or firmware) is owned by Cypress Semiconductor Corporation (Cypress) and is protected by and subject to worldwide patent protection (United States and foreign), United States copyright laws and international treaty provisions. Cypress hereby grants to licensee a personal, non-exclusive, non-transferable license to copy, use, modify, create derivative works of, and compile the Cypress Source Code and derivative works for the sole purpose of creating custom software and or firmware in support of licensee product to be used only in conjunction with a Cypress integrated circuit as specified in the applicable agreement. Any reproduction, modification, translation, compilation, or representation of this Source Code except as specified above is prohibited without the express written permission of Cypress.

Disclaimer: CYPRESS MAKES NO WARRANTY OF ANY KIND, EXPRESS OR IMPLIED, WITH REGARD TO THIS MATERIAL, INCLUDING, BUT NOT LIMITED TO, THE IMPLIED WARRANTIES OF MERCHANTABILITY AND FITNESS FOR A PARTICULAR PURPOSE. Cypress reserves the right to make changes without further notice to the materials described herein. Cypress does not assume any liability arising out of the application or use of any product or circuit described herein. Cypress does not authorize its products for use as critical components in life-support systems where a malfunction or failure may reasonably be expected to result in significant injury to the user. The inclusion of Cypress' product in a life-support systems application implies that the manufacturer assumes all risk of such use and in doing so indemnifies Cypress against all charges.

Use may be limited by and subject to the applicable Cypress software license agreement.

## OUR CERTIFICATE

DiGi provide top-quality products and perfect service for customer worldwide through standardization, technological innovation and continuous improvement. DiGi through third-party certification, we stricly control the quality of products and services. Welcome your RFQ to

Email: [Info@DiGi-Electronics.com](mailto:Info@DiGi-Electronics.com)



Tel: +00 852-30501935

RFQ Email: [Info@DiGi-Electronics.com](mailto:Info@DiGi-Electronics.com)

DiGi is a global authorized distributor of electronic components.