

CY7C10612G30-10ZSXI Datasheet

www.digi-electronics.com

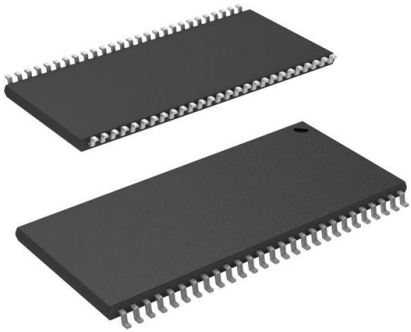

<https://www.DiGi-Electronics.com>

DiGi Electronics Part Number	CY7C10612G30-10ZSXI-DG
Manufacturer	Infineon Technologies
Manufacturer Product Number	CY7C10612G30-10ZSXI
Description	IC SRAM 16MBIT PAR 54TSOP II
Detailed Description	SRAM - Asynchronous Memory IC 16Mbit Parallel 10 ns 54-TSOP II

This model CY7C10612G30-10ZSXI is available at DiGi Electronics.

DiGi Electronics offers a global database of semiconductor and electronic component datasheets.

We welcome your inquiries regarding pricing, lead time, or other product-related questions.

 [Request a Quote](#)

 [Datasheet Search](#)



Tel: +00 852-30501935

RFQ Email: Info@DiGi-Electronics.com

DiGi is a global authorized distributor of electronic components.

Purchase and inquiry

Manufacturer Product Number:

CY7C10612G30-10ZSXI

Series:

-

DiGi-Electronics Programmable:

Not Verified

Memory Format:

SRAM

Memory Size:

16Mbit

Memory Interface:

Parallel

Access Time:

10 ns

Operating Temperature:

-40°C ~ 85°C (TA)

Package / Case:

54-TSOP (0.400", 10.16mm Width)

Base Product Number:

CY7C10612

Manufacturer:

Infineon Technologies

Product Status:

Active

Memory Type:

Volatile

Technology:

SRAM - Asynchronous

Memory Organization:

1M x 16

Write Cycle Time - Word, Page:

10ns

Voltage - Supply:

3V ~ 3.6V

Mounting Type:

Surface Mount

Supplier Device Package:

54-TSOP II

Environmental & Export classification

RoHS Status:

ROHS3 Compliant

REACH Status:

REACH Unaffected

HTSUS:

8542.32.0041

Moisture Sensitivity Level (MSL):

3 (168 Hours)

ECCN:

3A991B2A



Please note that Cypress is an Infineon Technologies Company.

The document following this cover page is marked as “Cypress” document as this is the company that originally developed the product. Please note that Infineon will continue to offer the product to new and existing customers as part of the Infineon product portfolio.

Continuity of document content

The fact that Infineon offers the following product as part of the Infineon product portfolio does not lead to any changes to this document. Future revisions will occur when appropriate, and any changes will be set out on the document history page.

Continuity of ordering part numbers

Infineon continues to support existing part numbers. Please continue to use the ordering part numbers listed in the datasheet for ordering.



CY7C10612G
CY7C10612GE

16-Mbit (1M × 16) Static RAM

Features

- High speed
 - $t_{AA} = 10$ ns
- Embedded error-correcting code (ECC) for single-bit error correction
- Low active power
 - $I_{CC} = 90$ mA typical
- Low CMOS standby power
 - $I_{SB2} = 20$ mA typical
- Operating voltages of 3.3 ± 0.3 V
- 1.0 V data retention
- Transistor-transistor logic (TTL) compatible inputs and outputs
- ERR pin to indicate 1-bit error detection and correction
- Available in Pb-free 54-pin TSOP II package

Functional Description

The CY7C10612G and CY7C10612GE are high performance CMOS fast static RAM devices with embedded ECC. These devices are offered in single chip enable option. The CY7C10612GE device includes an error indication pin that signals an error-detection and correction event during a read cycle.

To write to the device, take Chip Enables (\overline{CE}) and Write Enable (\overline{WE}) input LOW. If Byte Low Enable (\overline{BLE}) is LOW, then data from I/O pins (I/O₀ through I/O₇), is written into the location specified on the address pins (A₀ through A₁₉). If Byte High Enable (\overline{BHE}) is LOW, then data from I/O pins (I/O₈ through I/O₁₅) is written into the location specified on the address pins (A₀ through A₁₉).

To read from the device, take Chip Enable (\overline{CE}) and Output Enable (\overline{OE}) LOW while forcing the Write Enable (\overline{WE}) HIGH. If Byte Low Enable (\overline{BLE}) is LOW, then data from the memory location specified by the address pins appears on I/O₀ to I/O₇. If Byte High Enable (\overline{BHE}) is LOW, then data from memory appears on I/O₈ to I/O₁₅. See [Truth Table on page 14](#) for a complete description of Read and Write modes.

The input or output pins (I/O₀ through I/O₁₅) are placed in a high impedance state when the device is deselected (\overline{CE} HIGH), the outputs are disabled (\overline{OE} HIGH), the \overline{BHE} and \overline{BLE} are disabled (\overline{BHE} , \overline{BLE} HIGH), or during a write operation (\overline{CE} LOW and \overline{WE} LOW).

On the CY7C10612GE devices the detection and correction of a single-bit error in the accessed location is indicated by the assertion of the ERR output (ERR = high). See the [Truth Table on page 14](#) for a complete description of read and write modes.

The CY7C10612G and CY7C10612GE are available in a 54-pin TSOP II package.

For a complete list of related documentation, click [here](#).

Selection Guide

Description	-10	Unit
Maximum Access Time	10	ns
Maximum Operating Current	110	mA
Maximum CMOS Standby Current	30	mA



Logic Block Diagram – CY7C10612G

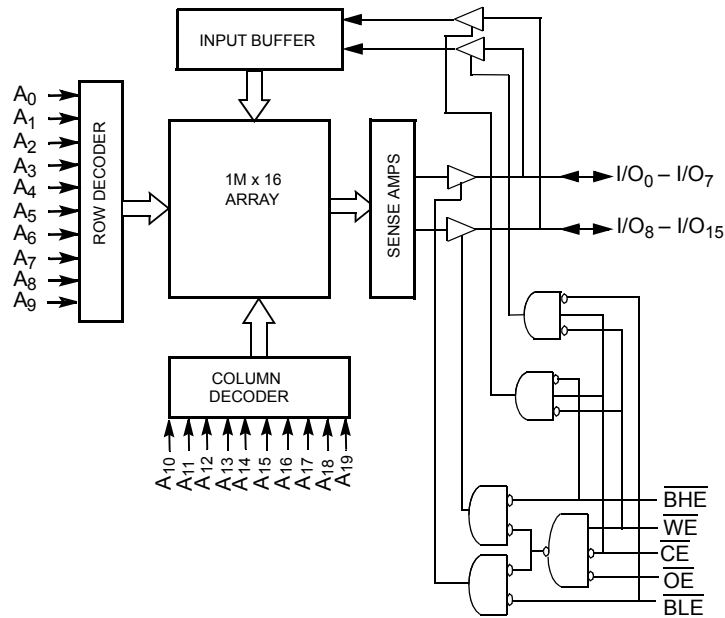

Logic Block Diagram – CY7C10612GE

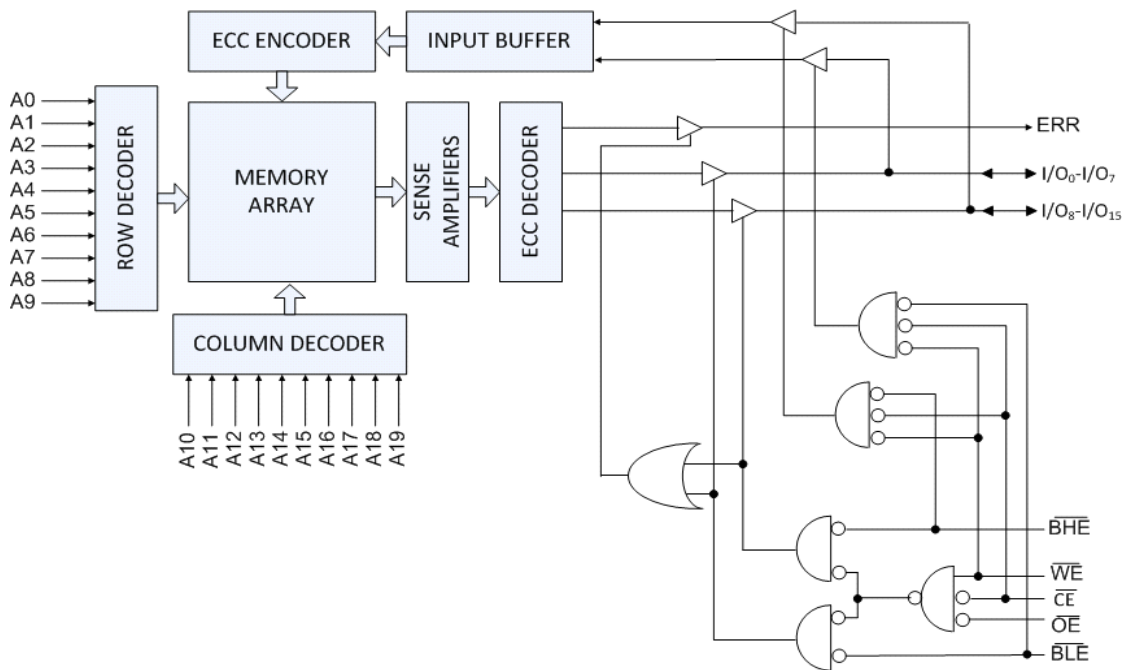



Contents

Pin Configurations	4	Ordering Information	15
Maximum Ratings	6	Ordering Code Definitions	15
Operating Range	6	Package Diagrams	16
DC Electrical Characteristics	6	Acronyms	17
Capacitance	7	Document Conventions	17
Thermal Resistance	7	Units of Measure	17
AC Test Loads and Waveforms	7	Document History Page	18
Data Retention Characteristics	8	Sales, Solutions, and Legal Information	19
Data Retention Waveform	8	Worldwide Sales and Design Support	19
AC Switching Characteristics	9	Products	19
Switching Waveforms	10	PSoC® Solutions	19
Truth Table	14	Cypress Developer Community	19
ERR Output – CY7C10612GE	14	Technical Support	19



Pin Configurations

Figure 1. 54-pin TSOP II pinout (Top View) ^[1]
 CY7C10612G

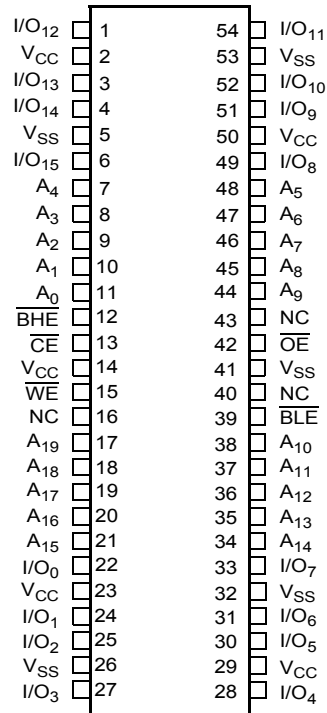

Note

1. NC pins are not connected on the die.

Pin Configurations (continued)

Figure 2. 54-pin TSOP II pinout with ERR (Top View) ^[2, 3]
CY7C10612GE

I/O ₁₂	1	54	I/O ₁₁
V _{CC}	2	53	V _{SS}
I/O ₁₃	3	52	I/O ₁₀
I/O ₁₄	4	51	I/O ₉
V _{SS}	5	50	V _{CC}
I/O ₁₅	6	49	I/O ₈
A ₄	7	48	A ₅
A ₃	8	47	A ₆
A ₂	9	46	A ₇
A ₁	10	45	A ₈
A ₀	11	44	A ₉
$\overline{\text{BHE}}$	12	43	ERR
$\overline{\text{CE}}$	13	42	$\overline{\text{OE}}$
V _{CC}	14	41	V _{SS}
$\overline{\text{WE}}$	15	40	NC
NC	16	39	$\overline{\text{BLE}}$
A ₁₉	17	38	A ₁₀
A ₁₈	18	37	A ₁₁
A ₁₇	19	36	A ₁₂
A ₁₆	20	35	A ₁₃
A ₁₅	21	34	A ₁₄
I/O ₀	22	33	I/O ₇
V _{CC}	23	32	V _{SS}
I/O ₁	24	31	I/O ₆
I/O ₂	25	30	I/O ₅
V _{SS}	26	29	V _{CC}
I/O ₃	27	28	I/O ₄

Note

2. NC pins are not connected on the die.
3. ERR is an Output pin. If not used, this pin should be left floating.



Maximum Ratings

Exceeding maximum ratings may shorten the useful life of the device. User guidelines are not tested.

Storage Temperature -65 °C to +150 °C

Ambient Temperature
with Power Applied -55 °C to +125 °C

Supply Voltage
on V_{CC} Relative to GND^[4] -0.5 V to $V_{CC} + 0.5$ V

DC Voltage Applied to Outputs
in High Z State^[4] -0.5 V to $V_{CC} + 0.5$ V

DC Input Voltage^[4] -0.5 V to $V_{CC} + 0.5$ V

Current into Outputs (LOW) 20 mA

Static Discharge Voltage
(MIL-STD-883, Method 3015) > 2001 V

Latch Up Current > 200 mA

Operating Range

Range	Ambient Temperature	V_{CC}
Industrial	-40 °C to +85 °C	3.3 V ± 0.3 V

DC Electrical Characteristics

Over the operating range of -40 °C to 85 °C

Parameter	Description	Test Conditions	10 ns			Unit	
			Min	Typ ^[5]	Max		
V_{OH}	Output HIGH Voltage	2.2 V to 2.7 V	$V_{CC} = \text{Min}, I_{OH} = -4.0$ mA	2.2	-	-	V
		2.7 V to 3.0 V	$V_{CC} = \text{Min}, I_{OH} = -4.0$ mA	2.4	-	-	
V_{OL}	Output LOW Voltage	$V_{CC} = \text{Min}, I_{OL} = 8$ mA	-	-	0.4	V	
V_{IH} ^[4]	Input HIGH Voltage	-	2.0	-	$V_{CC} + 0.3$	V	
V_{IL} ^[4]	Input LOW Voltage	-	-0.3	-	0.8	V	
I_{IX}	Input Leakage Current	$GND \leq V_{IN} \leq V_{CC}$	-1.0	-	+1.0	µA	
I_{OZ}	Output Leakage Current	$GND \leq V_{OUT} \leq V_{CC}$, Output disabled	-1.0	-	+1.0	µA	
I_{CC}	Operating Supply Current	$V_{CC} = \text{Max}, I_{OUT} = 0$ mA, CMOS levels	f = 100 MHz	-	90.0	110.0	mA
			f = 66.7 MHz	-	70.0	80.0	
I_{SB1}	Automatic CE Power-down Current – TTL Inputs	Max V_{CC} , $\overline{CE} \geq V_{IH}$ ^[5] , $V_{IN} \geq V_{IH}$ or $V_{IN} \leq V_{IL}$, f = f_{MAX}	-	-	40.0	mA	
I_{SB2}	Automatic CE Power-down Current – CMOS Inputs	Max V_{CC} , $\overline{CE} \geq V_{CC} - 0.2$ V ^[5] , $V_{IN} \geq V_{CC} - 0.2$ V or $V_{IN} \leq 0.2$ V, f = 0	-	20.0	30.0	mA	

Notes

4. $V_{IL(\text{min})} = -2.0$ V and $V_{IH(\text{max})} = V_{CC} + 2$ V for pulse durations of less than 20 ns.

5. Typical values are included only for reference and are not guaranteed or tested. Typical values are measured at $V_{CC} = 1.8$ V (for a V_{CC} range of 1.65 V–2.2 V), $V_{CC} = 3$ V (for a V_{CC} range of 2.2 V–3.6 V), and $V_{CC} = 5$ V (for a V_{CC} range of 4.5 V–5.5 V), $T_A = 25$ °C.



Capacitance

Parameter [6]	Description	Test Conditions	54-pin TSOP II	Unit
C_{IN}	Input Capacitance	$T_A = 25\text{ }^\circ\text{C}$, $f = 1\text{ MHz}$, $V_{CC} = 3.3\text{ V}$	10	pF
C_{OUT}	I/O Capacitance			

Thermal Resistance

Parameter [6]	Description	Test Conditions	54-pin TSOP II	Unit
Θ_{JA}	Thermal Resistance (junction to ambient)	Still air, soldered on a 3 × 4.5 inch, four-layer printed circuit board	93.63	$^\circ\text{C/W}$
Θ_{JC}	Thermal Resistance (junction to case)		21.58	

AC Test Loads and Waveforms

Figure 3. AC Test Loads and Waveforms [7]

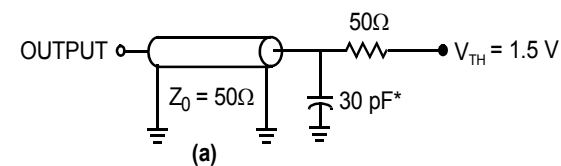

* CAPACITIVE LOAD CONSISTS OF ALL COMPONENTS OF THE TEST ENVIRONMENT

HIGH Z CHARACTERISTICS:

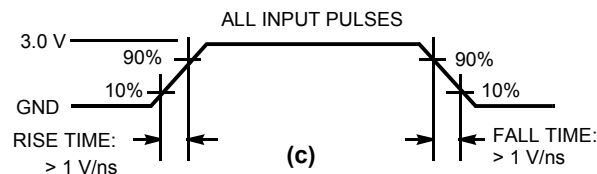
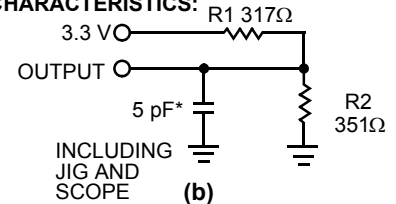

Notes

- Tested initially and after any design or process changes that may affect these parameters.
- Full-device AC operation assumes a 100- μs ramp time from 0 to V_{CC} (min) and 100- μs wait time after V_{CC} stabilizes to its operational value.



Data Retention Characteristics

Over the Operating Range $-45\text{ }^{\circ}\text{C}$ to $85\text{ }^{\circ}\text{C}$

Parameter	Description	Conditions	Min	Typ ^[8]	Max	Unit
V_{DR}	V_{CC} for Data Retention	–	1.0	–	–	V
I_{CCDR}	Data Retention Current	$V_{CC} = 2\text{ V}$, $\overline{CE} \geq V_{CC} - 0.2\text{ V}$, $V_{IN} \geq V_{CC} - 0.2\text{ V}$ or $V_{IN} \leq 0.2\text{ V}$	–	–	30.0	mA
$t_{CDR}^{[9]}$	Chip Deselect to Data Retention Time	–	0.0	–	–	ns
$t_R^{[9, 10]}$	Operation Recovery Time	–	10.0	–	–	ns

Data Retention Waveform

Figure 4. Data Retention Waveform

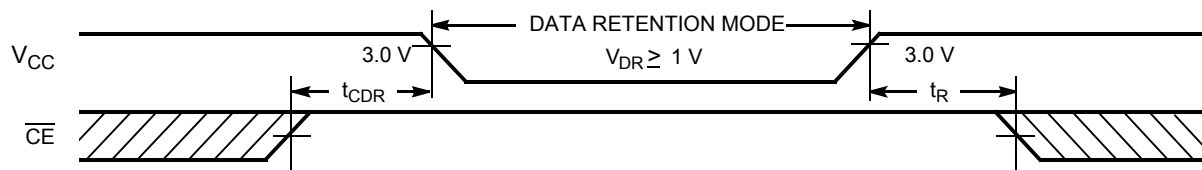

Notes

8. Typical values are included for reference only and are not guaranteed or tested. Typical values are measured at $V_{CC} = V_{CC(\text{typ})}$, $T_A = 25\text{ }^{\circ}\text{C}$.

9. This parameter is guaranteed by design and is not tested.

10. Full device operation requires linear V_{CC} ramp from V_{DR} to $V_{CC(\text{min.})} \geq 100\text{ }\mu\text{s}$ or stable at $V_{CC(\text{min.})} \geq 100\text{ }\mu\text{s}$.



AC Switching Characteristics

Over the Operating Range

Parameter ^[11]	Description	-10		Unit
		Min	Max	
Read Cycle				
t_{POWER}	V_{CC} to the first access ^[12]	100.0	–	μ s
t_{RC}	Read cycle time	10.0	–	ns
t_{AA}	Address to data valid	–	10.0	ns
t_{OHA}	Data hold from address change	3.0	–	ns
t_{ACE}	\overline{CE} LOW to data valid	–	10.0	ns
t_{DOE}	\overline{OE} LOW to data valid	–	5.0	ns
t_{LZOE}	\overline{OE} LOW to low Z ^[13, 14, 15]	0.0	–	ns
t_{HZOE}	\overline{OE} HIGH to high Z ^[13, 14, 15]	–	5.0	ns
t_{LZCE}	\overline{CE} LOW to low Z ^[13, 14, 15]	3.0	–	ns
t_{HZCE}	\overline{CE} HIGH to high Z ^[13, 14, 15]	–	5.0	ns
t_{PU}	\overline{CE} LOW to power-up ^[16]	0.0	–	ns
t_{PD}	\overline{CE} HIGH to power-down ^[16]	–	10.0	ns
t_{DBE}	Byte enable to data valid	–	5.0	ns
t_{LZBE}	Byte enable to low Z	1.0	–	ns
t_{HZBE}	Byte disable to high Z	–	6.0	ns
Write Cycle ^[17, 18]				
t_{WC}	Write cycle time	10.0	–	ns
t_{SCE}	\overline{CE} LOW to write end	7.0	–	ns
t_{AW}	Address setup to write end	7.0	–	ns
t_{HA}	Address hold from write end	0.0	–	ns
t_{SA}	Address setup to write start	0.0	–	ns
t_{PWE}	\overline{WE} pulse width	7.0	–	ns
t_{SD}	Data setup to write end	5.0	–	ns
t_{HD}	Data hold from write end	0.0	–	ns
t_{LZWE}	\overline{WE} HIGH to low Z ^[13, 14, 15]	3.0	–	ns
t_{HZWE}	\overline{WE} LOW to high Z ^[13, 14, 15]	–	5.0	ns
t_{BW}	Byte enable to end of write	7.0	–	ns

Notes

- Test conditions assume signal transition time of 3 ns or less, timing reference levels of 1.5 V, and input pulse levels of 0 to 3.0 V. Test conditions for the read cycle use output loading shown in part a) of Figure 3 on page 7, unless specified otherwise.
- t_{POWER} gives the minimum amount of time that the power supply is at typical V_{CC} values until the first memory access is performed.
- t_{HZOE} , t_{HZCE} , t_{HZWE} , t_{HZBE} , t_{LZOE} , t_{LZCE} , t_{LZWE} , and t_{LZBE} are specified with a load capacitance of 5 pF as in (b) of Figure 3 on page 7. Transition is measured ± 200 mV from steady state voltage.
- At any temperature and voltage condition, t_{HZCE} is less than t_{LZCE} , t_{HZBE} is less than t_{LZBE} , t_{HZOE} is less than t_{LZOE} , and t_{HZWE} is less than t_{LZWE} for any device.
- Tested initially and after any design or process changes that may affect these parameters.
- These parameters are guaranteed by design and are not tested.
- The internal write time of the memory is defined by the overlap of \overline{WE} , $\overline{CE} = V_{IL}$. Chip enable must be active and \overline{WE} and byte enables must be LOW to initiate a write, and the transition of any of these signals can terminate. The input data setup and hold timing should be referenced to the edge of the signal that terminates the write.
- The minimum write cycle time for Write Cycle No. 2 (\overline{WE} Controlled, \overline{OE} LOW) is the sum of t_{HZWE} and t_{SD} .



Switching Waveforms

Figure 5. Read Cycle No. 1 (Address Transition Controlled) for CY7C10612G [19, 20]

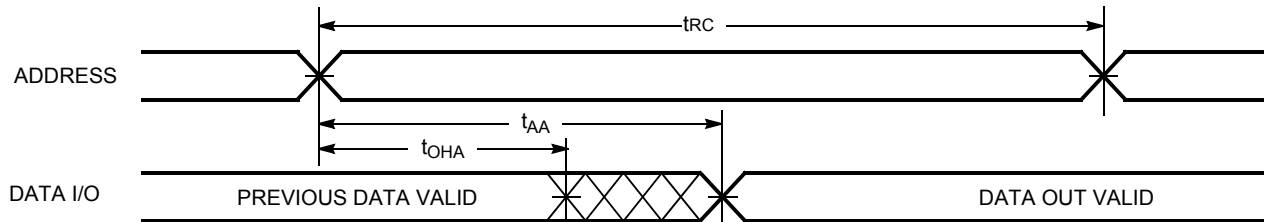
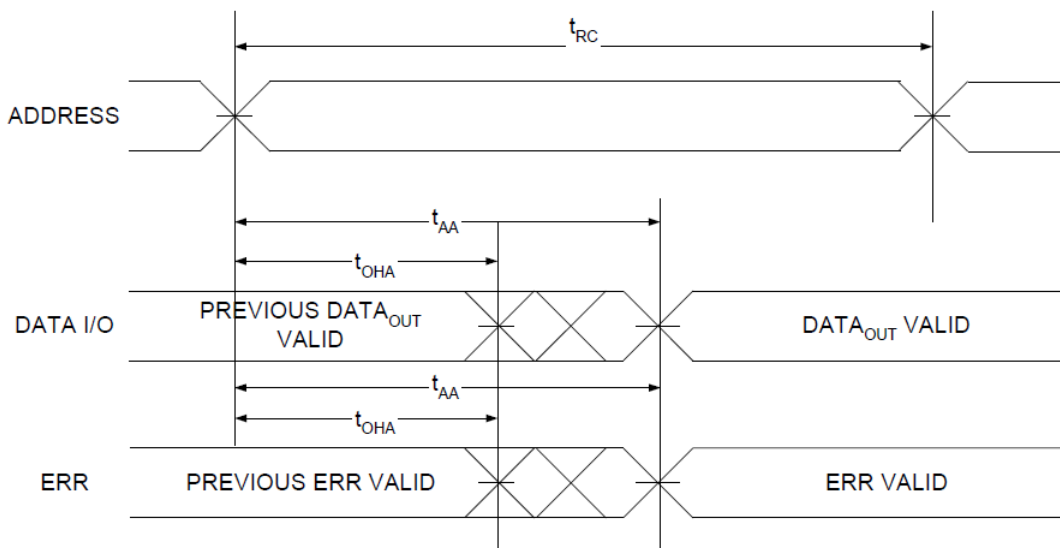

Figure 6. Read Cycle No. 1 (Address Transition Controlled) for CY7C10612GE [20, 21]



Notes

19. The device is continuously selected. \overline{OE} , $\overline{CE} = V_{IL}$, \overline{BHE} , \overline{BLE} or both = V_{IL} .

20. \overline{WE} is HIGH for read cycle.

21. Address valid before or similar to \overline{CE} transition LOW.



Switching Waveforms (continued)

Figure 7. Read Cycle No. 2 ($\overline{\text{OE}}$ Controlled) [22, 23]

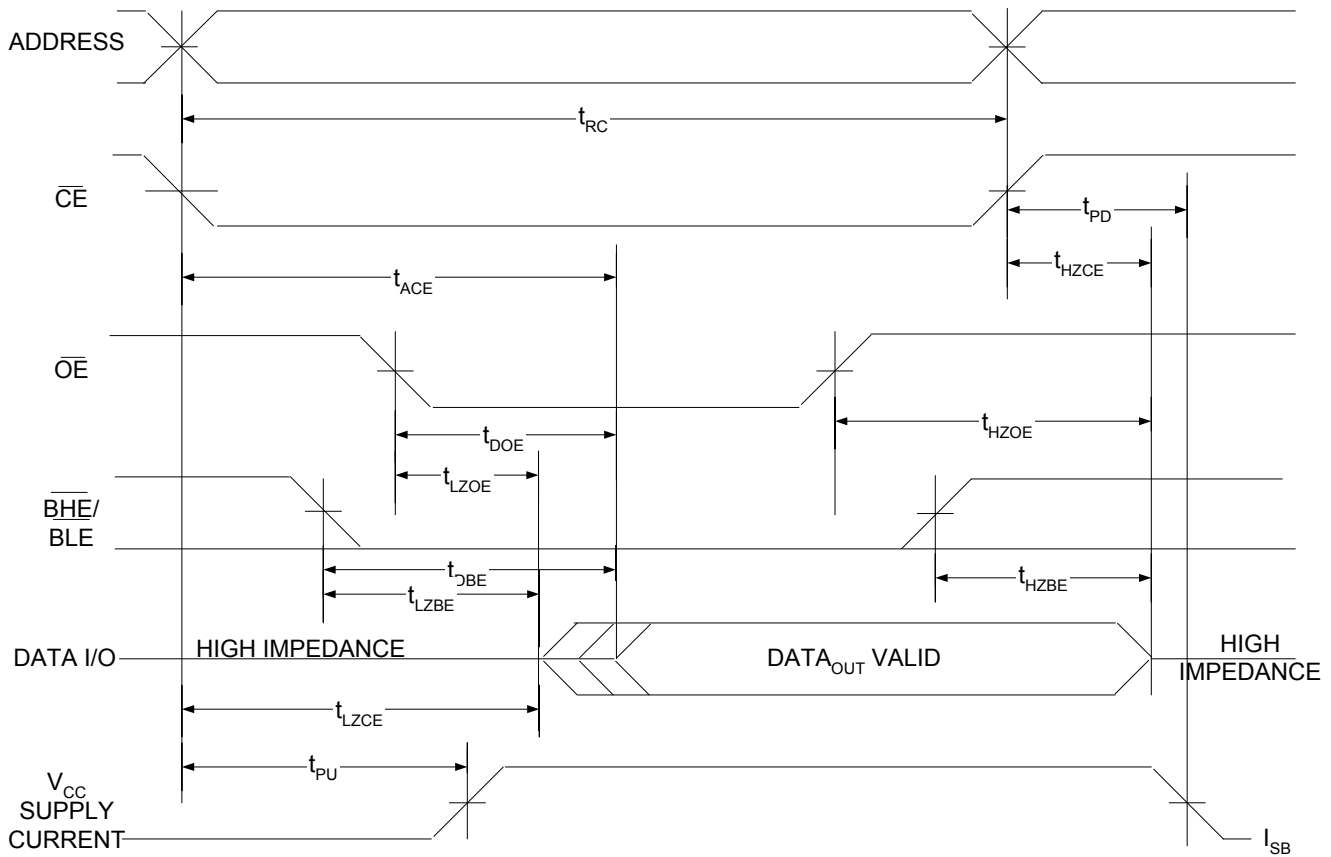

Notes

22. $\overline{\text{WE}}$ is HIGH for read cycle.
23. Address valid before or similar to $\overline{\text{CE}}$ transition LOW.

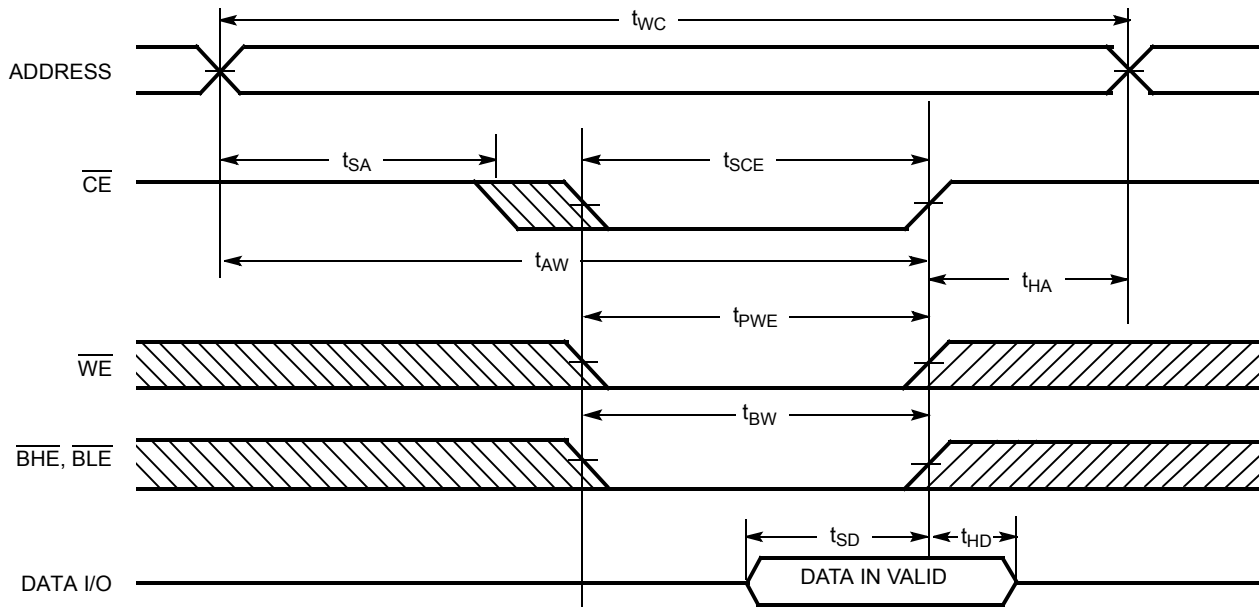
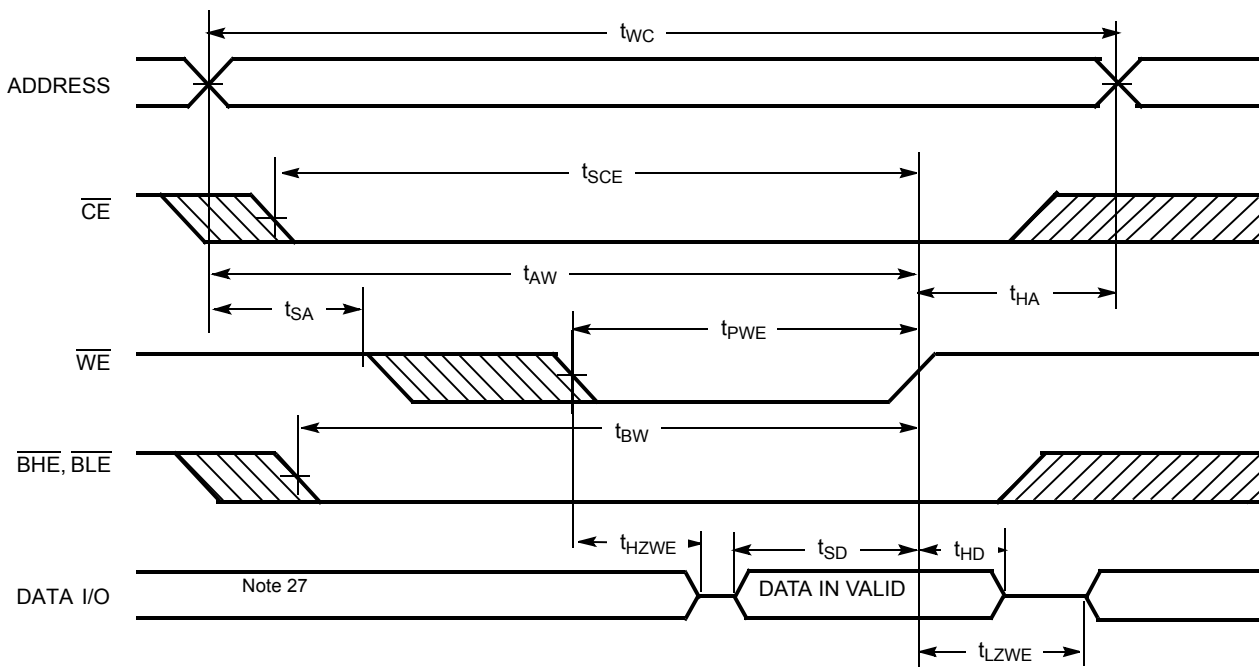

Switching Waveforms (continued)

Figure 8. Write Cycle No. 1 ($\overline{\text{CE}}$ Controlled) [24, 25, 26]Figure 9. Write Cycle No. 2 ($\overline{\text{WE}}$ Controlled, $\overline{\text{OE}}$ LOW) [24, 25, 26]

Notes

24. Data I/O is high impedance if $\overline{\text{OE}}$, $\overline{\text{BHE}}$, and/or $\overline{\text{BLE}} = V_{IH}$.

25. The internal write time of the memory is defined by the overlap of $\overline{\text{WE}} = V_{IL}$, $\overline{\text{CE}} = V_{IL}$ and $\overline{\text{BHE}}$ or $\overline{\text{BLE}} = V_{IL}$. These signals must be LOW to initiate a write, and the HIGH transition of any of these signals can terminate the operation. The input data setup and hold timing should be referenced to the edge of the signal that terminates the write.

26. The minimum write cycle pulse width should be equal to the sum of t_{HZWE} and t_{SD} .

27. During this period the I/Os are in output state. Do not apply input signals.



Switching Waveforms (continued)

Figure 10. Write Cycle No. 3 (BLE or BHE Controlled) [28, 29]

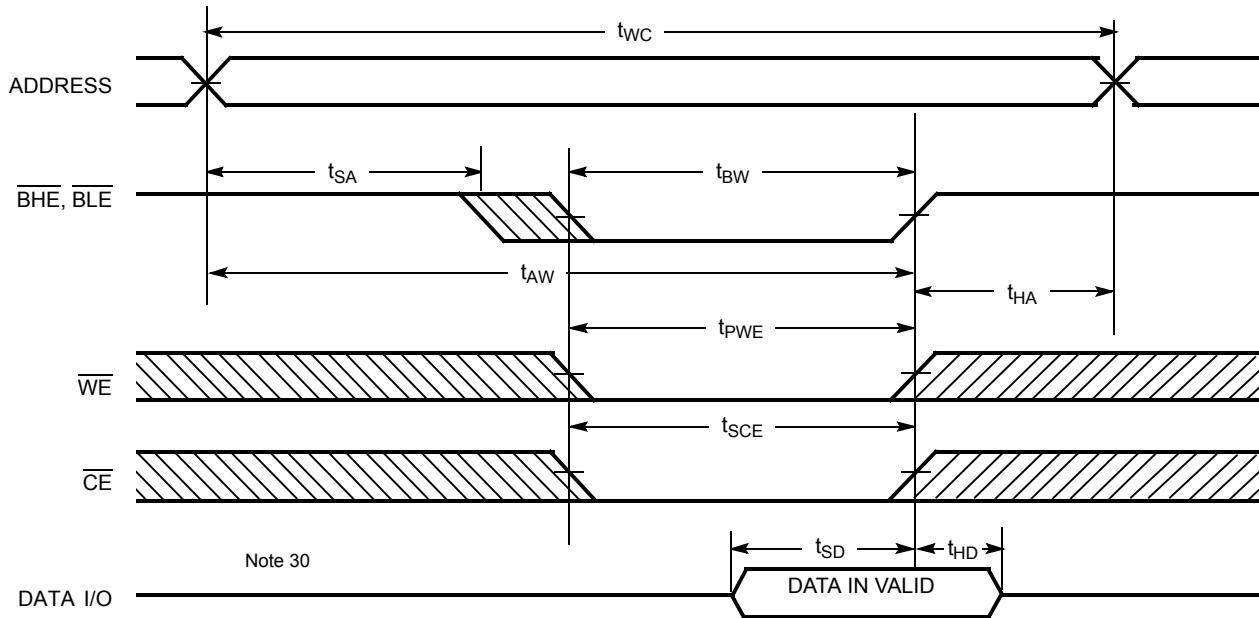

Note 30

Notes

28. Data I/O is high impedance if \overline{OE} , \overline{BHE} , and/or $\overline{BLE} = V_{IH}$.

29. The internal write time of the memory is defined by the overlap of $\overline{WE} = V_{IL}$, $\overline{CE} = V_{IL}$ and \overline{BHE} or $\overline{BLE} = V_{IL}$. These signals must be LOW to initiate a write, and the HIGH transition of any of these signals can terminate the operation. The input data setup and hold timing should be referenced to the edge of the signal that terminates the write.

30. During this period, the I/Os are in output state. Do not apply input signals.



Truth Table

$\overline{\text{CE}}$	$\overline{\text{OE}}$	$\overline{\text{WE}}$	$\overline{\text{BLE}}$	$\overline{\text{BHE}}$	I/O ₀ -I/O ₇	I/O ₈ -I/O ₁₅	Mode	Power
H	X	X	X	X	High Z	High Z	Power-down	Standby (I _{SB})
L	L	H	L	L	Data Out	Data Out	Read all bits	Active (I _{CC})
L	L	H	L	H	Data Out	High Z	Read lower bits only	Active (I _{CC})
L	L	H	H	L	High Z	Data Out	Read upper bits only	Active (I _{CC})
L	X	L	L	L	Data In	Data In	Write all bits	Active (I _{CC})
L	X	L	L	H	Data In	High Z	Write lower bits only	Active (I _{CC})
L	X	L	H	L	High Z	Data In	Write upper bits only	Active (I _{CC})
L	H	H	X	X	High Z	High Z	Selected, outputs disabled	Active (I _{CC})

ERR Output – CY7C10612GE

Output ^[31]	Mode
0	Read Operation, no error in the stored data.
1	Read Operation, single-bit error detected and corrected.
High-Z	Device deselected or Outputs disabled or Write Operation.

Note

³¹. ERR is an Output pin. If not used, this pin should be left floating.



Ordering Information

Speed (ns)	Ordering Code	Package Diagram	Package Type (Pb-free)	Operating Range
10	CY7C10612G30-10ZSXI	51-85160	54-pin TSOP II	Industrial
	CY7C10612G30-10ZSXIT		54-pin TSOP II, Tape and Reel	
	CY7C10612GE30-10ZSXI		54-pin TSOP II, with ERR Pin	
	CY7C10612GE30-10ZSXIT		54-pin TSOP II, with ERR Pin, Tape and Reel	

Ordering Code Definitions

CY	7	C	1	06	1	2	G	E	30	-	10	ZS	X	I	X
<p>X = blank or T blank = Bulk; T = Tape and Reel</p> <p>Temperature Range: I = Industrial</p> <p>Pb-free</p> <p>Package Type: ZS = 54-pin TSOP II</p> <p>Speed Grade: 10 ns</p> <p>Voltage Range: 30 = 3 V to 3.6 V</p> <p>X = blank or E blank = without ERR output; E = with ERR output, Single bit error correction indicator</p> <p>Process Technology: G = 65 nm</p> <p>Single chip enable</p> <p>Bus Width: 1 = × 16</p> <p>Density: 06 = 16-Mbit</p> <p>Fast asynchronous SRAM family</p> <p>Technology Code: C = CMOS</p> <p>Marketing Code: 7 = SRAM</p> <p>Company ID: CY = Cypress</p>															



Package Diagrams

Figure 11. 54-pin TSOP II (22.4 × 11.84 × 1.0 mm) Z54-II Package Outline, 51-85160

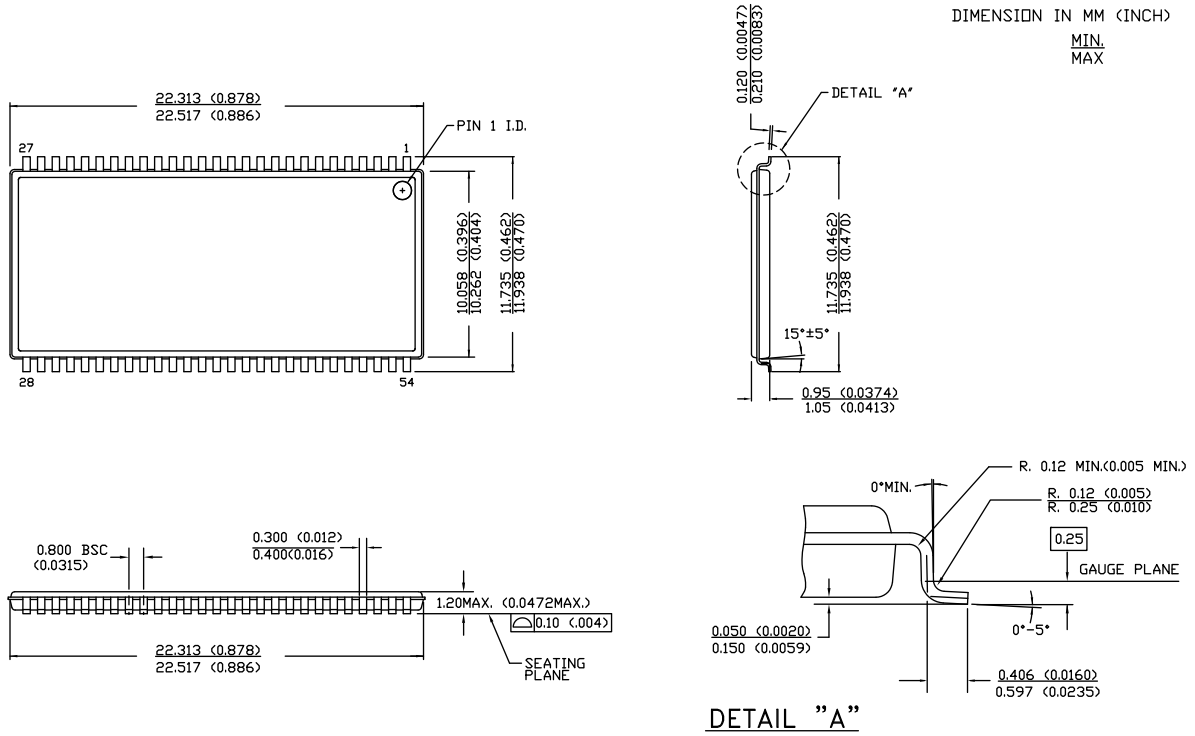

51-85160 *E



Acronyms

Table 1. Acronyms Used in this Document

Acronym	Description
$\overline{\text{BHE}}$	Byte High Enable
$\overline{\text{BLE}}$	Byte Low Enable
$\overline{\text{CE}}$	Chip Enable
CMOS	Complementary Metal Oxide Semiconductor
I/O	Input/Output
$\overline{\text{OE}}$	Output Enable
SRAM	Static Random Access Memory
TSOP	Thin Small Outline Package
TTL	Transistor-Transistor Logic
$\overline{\text{WE}}$	Write Enable

Document Conventions

Units of Measure

Table 2. Units of Measure

Symbol	Unit of Measure
$^{\circ}\text{C}$	degree Celsius
MHz	megahertz
μA	microampere
μs	microsecond
mA	milliampere
mm	millimeter
mV	millivolt
ns	nanosecond
Ω	ohm
%	percent
pF	picofarad
V	volt
W	watt



Document History Page

Document Title: CY7C10612G/CY7C10612GE, 16-Mbit (1M × 16) Static RAM				
Document Number: 001-88702				
Rev.	ECN No.	Orig. of Change	Submission Date	Description of Change
*D	4865557	NILE	07/31/2015	Changed status from Preliminary to Final.
*E	5437839	NILE	09/15/2016	Updated Maximum Ratings : Updated Note 4 (Replaced “2 ns” with “20 ns”). Updated DC Electrical Characteristics : Removed all values corresponding to V _{OH} parameter. Included Operating Ranges “2.2 V to 2.7 V” and “2.7 V to 3.0 V” and all values corresponding to V _{OH} parameter. Updated Ordering Information : Updated part numbers. Updated Ordering Code Definitions . Updated to new template. Completing Sunset Review.
*F	6011828	AESATMP8	01/03/2018	Updated logo and Copyright.



Sales, Solutions, and Legal Information

Worldwide Sales and Design Support

Cypress maintains a worldwide network of offices, solution centers, manufacturer's representatives, and distributors. To find the office closest to you, visit us at [Cypress Locations](#).

Products

Arm® Cortex® Microcontrollers	cypress.com/arm
Automotive	cypress.com/automotive
Clocks & Buffers	cypress.com/clocks
Interface	cypress.com/interface
Internet of Things	cypress.com/iot
Memory	cypress.com/memory
Microcontrollers	cypress.com/mcu
PSoC	cypress.com/psoc
Power Management ICs	cypress.com/pmic
Touch Sensing	cypress.com/touch
USB Controllers	cypress.com/usb
Wireless Connectivity	cypress.com/wireless

PSoC® Solutions

[PSoC 1](#) | [PSoC 3](#) | [PSoC 4](#) | [PSoC 5LP](#) | [PSoC 6 MCU](#)

Cypress Developer Community

[Community](#) | [Projects](#) | [Video](#) | [Blogs](#) | [Training](#) | [Components](#)

Technical Support

cypress.com/support

© Cypress Semiconductor Corporation, 2013-2018. This document is the property of Cypress Semiconductor Corporation and its subsidiaries, including Spansion LLC ("Cypress"). This document, including any software or firmware included or referenced in this document ("Software"), is owned by Cypress under the intellectual property laws and treaties of the United States and other countries worldwide. Cypress reserves all rights under such laws and treaties and does not, except as specifically stated in this paragraph, grant any license under its patents, copyrights, trademarks, or other intellectual property rights. If the Software is not accompanied by a license agreement and you do not otherwise have a written agreement with Cypress governing the use of the Software, then Cypress hereby grants you a personal, non-exclusive, nontransferable license (without the right to sublicense) (1) under its copyright rights in the Software (a) for Software provided in source code form, to modify and reproduce the Software solely for use with Cypress hardware products, only internally within your organization, and (b) to distribute the Software in binary code form externally to end users (either directly or indirectly through resellers and distributors), solely for use on Cypress hardware product units, and (2) under those claims of Cypress's patents that are infringed by the Software (as provided by Cypress, unmodified) to make, use, distribute, and import the Software solely for use with Cypress hardware products. Any other use, reproduction, modification, translation, or compilation of the Software is prohibited.

TO THE EXTENT PERMITTED BY APPLICABLE LAW, CYPRESS MAKES NO WARRANTY OF ANY KIND, EXPRESS OR IMPLIED, WITH REGARD TO THIS DOCUMENT OR ANY SOFTWARE OR ACCOMPANYING HARDWARE, INCLUDING, BUT NOT LIMITED TO, THE IMPLIED WARRANTIES OF MERCHANTABILITY AND FITNESS FOR A PARTICULAR PURPOSE. No computing device can be absolutely secure. Therefore, despite security measures implemented in Cypress hardware or software products, Cypress does not assume any liability arising out of any security breach, such as unauthorized access to or use of a Cypress product. In addition, the products described in these materials may contain design defects or errors known as errata which may cause the product to deviate from published specifications. To the extent permitted by applicable law, Cypress reserves the right to make changes to this document without further notice. Cypress does not assume any liability arising out of the application or use of any product or circuit described in this document. Any information provided in this document, including any sample design information or programming code, is provided only for reference purposes. It is the responsibility of the user of this document to properly design, program, and test the functionality and safety of any application made of this information and any resulting product. Cypress products are not designed, intended, or authorized for use as critical components in systems designed or intended for the operation of weapons, weapons systems, nuclear installations, life-support devices or systems, other medical devices or systems (including resuscitation equipment and surgical implants), pollution control or hazardous substances management, or other uses where the failure of the device or system could cause personal injury, death, or property damage ("Unintended Uses"). A critical component is any component of a device or system whose failure to perform can be reasonably expected to cause the failure of the device or system, or to affect its safety or effectiveness. Cypress is not liable, in whole or in part, and you shall and hereby do release Cypress from any claim, damage, or other liability arising from or related to all Unintended Uses of Cypress products. You shall indemnify and hold Cypress harmless from and against all claims, costs, damages, and other liabilities, including claims for personal injury or death, arising from or related to any Unintended Uses of Cypress products.

Cypress, the Cypress logo, Spansion, the Spansion logo, and combinations thereof, WICED, PSoC, CapSense, EZ-USB, F-RAM, and Traveo are trademarks or registered trademarks of Cypress in the United States and other countries. For a more complete list of Cypress trademarks, visit cypress.com. Other names and brands may be claimed as property of their respective owners.

OUR CERTIFICATE

DiGi provide top-quality products and perfect service for customer worldwide through standardization, technological innovation and continuous improvement. DiGi through third-party certification, we stricly control the quality of products and services. Welcome your RFQ to

Email: Info@DiGi-Electronics.com



Tel: +00 852-30501935

RFQ Email: Info@DiGi-Electronics.com

DiGi is a global authorized distributor of electronic components.