

# CY7C1352G-133AXC Datasheet

[www.digi-electronics.com](http://www.digi-electronics.com)

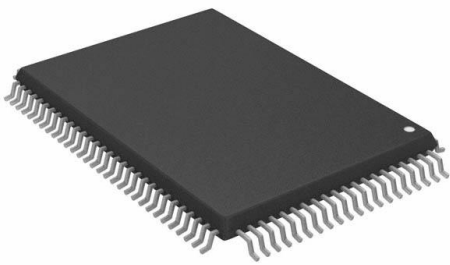

<https://www.DiGi-Electronics.com>

DiGi Electronics Part Number	CY7C1352G-133AXC-DG
Manufacturer	<a href="#">Infineon Technologies</a>
Manufacturer Product Number	CY7C1352G-133AXC
Description	IC SRAM 4.5MBIT PAR 100TQFP
Detailed Description	SRAM - Synchronous, SDR Memory IC 4.5Mbit Parallel 133 MHz 4 ns 100-TQFP (14x20)

This model CY7C1352G-133AXC is available at DiGi Electronics.

DiGi Electronics offers a global database of semiconductor and electronic component datasheets.

We welcome your inquiries regarding pricing, lead time, or other product-related questions.

 [Request a Quote](#)

 [Datasheet Search](#)



Tel: +00 852-30501935

RFQ Email: [Info@DiGi-Electronics.com](mailto:Info@DiGi-Electronics.com)

DiGi is a global authorized distributor of electronic components.

## Purchase and inquiry

Manufacturer Product Number:

CY7C1352G-133AXC

Series:

NoBL™

DiGi-Electronics Programmable:

Not Verified

Memory Format:

SRAM

Memory Size:

4.5Mbit

Memory Interface:

Parallel

Write Cycle Time - Word, Page:

-

Voltage - Supply:

3.135V ~ 3.6V

Mounting Type:

Surface Mount

Supplier Device Package:

100-TQFP (14x20)

Manufacturer:

Infineon Technologies

Product Status:

Active

Memory Type:

Volatile

Technology:

SRAM - Synchronous, SDR

Memory Organization:

256K x 18

Clock Frequency:

133 MHz

Access Time:

4 ns

Operating Temperature:

0°C ~ 70°C (TA)

Package / Case:

100-LQFP

Base Product Number:

CY7C1352

## Environmental & Export classification

RoHS Status:

ROHS3 Compliant

REACH Status:

REACH Unaffected

HTSUS:

8542.32.0041

Moisture Sensitivity Level (MSL):

3 (168 Hours)

ECCN:

3A991B2A

**CY7C1352G**

## 4-Mbit (256K × 18) Pipelined SRAM with NoBL™ Architecture

### Features

- Pin compatible and functionally equivalent to ZBT™ devices
- Internally self-timed output buffer control to eliminate the need to use  $\overline{OE}$
- Byte write capability
- 256K × 18 common I/O architecture
- 3.3 V core power supply ( $V_{DD}$ )
- 2.5 V/3.3 V I/O power supply ( $V_{DDQ}$ )
- Fast clock-to-output times
  - 4.0 ns (for 133-MHz device)
- Clock enable ( $\overline{CEN}$ ) pin to suspend operation
- Synchronous self-timed writes
- Asynchronous output enable ( $\overline{OE}$ )
- Available in Pb-free 100-pin TQFP package
- Burst capability – linear or interleaved burst order
- ZZ sleep mode option and stop clock option

### Functional Description

The CY7C1352G is a 3.3 V, 256K × 18 synchronous-pipelined burst SRAM designed specifically to support unlimited true back-to-back read/write operations without the insertion of wait states. The CY7C1352G is equipped with the advanced No Bus Latency™ (NoBL™) logic required to enable consecutive read/write operations with data being transferred on every clock cycle. This feature dramatically improves the throughput of the SRAM, especially in systems that require frequent write/read transitions.

All synchronous inputs pass through input registers controlled by the rising edge of the clock. All data outputs pass through output registers controlled by the rising edge of the clock. The clock input is qualified by the clock enable ( $\overline{CEN}$ ) signal, which, when deasserted, suspends operation and extends the previous clock cycle. Maximum access delay from the clock rise is 4.0 ns (133-MHz device).

Write operations are controlled by the two byte write select ( $BW_{[A:B]}$ ) and a write enable ( $\overline{WE}$ ) input. All writes are conducted with on-chip synchronous self-timed write circuitry.

Three synchronous chip enables ( $\overline{CE}_1$ ,  $\overline{CE}_2$ ,  $\overline{CE}_3$ ) and an asynchronous output enable ( $\overline{OE}$ ) provide for easy bank selection and output tri-state control. In order to avoid bus contention, the output drivers are synchronously tri-stated during the data portion of a write sequence.

For a complete list of related documentation, click [here](#).

### Selection Guide

Description	133 MHz	Unit
Maximum access time	4.0	ns
Maximum operating current	225	mA
Maximum CMOS standby current	40	mA

**Errata:** For information on silicon errata, see "Errata" on page 19. Details include trigger conditions, devices affected, and proposed workaround.



**Logic Block Diagram – CY7C1352G**

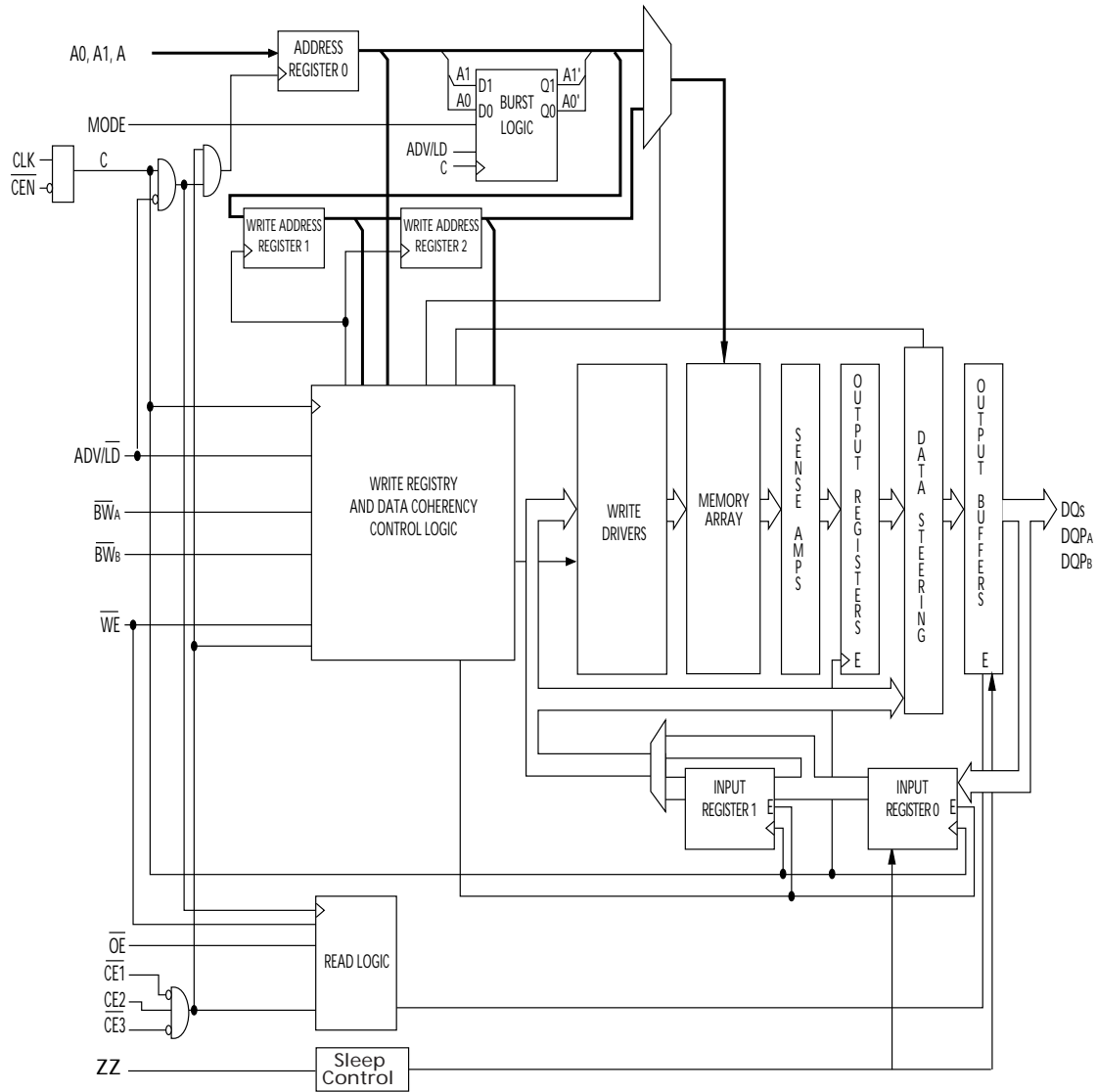



## Contents

<b>Pin Configuration</b> .....	<b>4</b>	<b>Switching Characteristics</b> .....	<b>13</b>
<b>Pin Definitions</b> .....	<b>5</b>	<b>Switching Waveforms</b> .....	<b>14</b>
<b>Functional Overview</b> .....	<b>7</b>	<b>Ordering Information</b> .....	<b>16</b>
Single Read Accesses .....	7	Ordering Code Definitions .....	16
Burst Read Accesses .....	7	<b>Package Diagram</b> .....	<b>17</b>
Single Write Accesses .....	7	<b>Acronyms</b> .....	<b>18</b>
Burst Write Accesses .....	7	<b>Document Conventions</b> .....	<b>18</b>
Sleep Mode .....	8	Units of Measure .....	18
Interleaved Burst Address Table .....	8	<b>Errata</b> .....	<b>19</b>
Linear Burst Address Table .....	8	Part Numbers Affected .....	19
ZZ Mode Electrical Characteristics .....	8	Product Status .....	19
<b>Truth Table</b> .....	<b>9</b>	Ram9 NoBL ZZ Pin Issues Errata Summary .....	19
<b>Truth Table for Read/Write</b> .....	<b>10</b>	<b>Document History Page</b> .....	<b>20</b>
<b>Maximum Ratings</b> .....	<b>11</b>	<b>Sales, Solutions, and Legal Information</b> .....	<b>22</b>
<b>Operating Range</b> .....	<b>11</b>	Worldwide Sales and Design Support .....	22
<b>Electrical Characteristics</b> .....	<b>11</b>	Products .....	22
<b>Capacitance</b> .....	<b>12</b>	PSoC@Solutions .....	22
<b>Thermal Resistance</b> .....	<b>12</b>	Cypress Developer Community .....	22
<b>AC Test Loads and Waveforms</b> .....	<b>12</b>	Technical Support .....	22



**Pin Configuration**

**Figure 1. 100-pin TQFP (14 × 20 × 1.4 mm) pinout [1]**

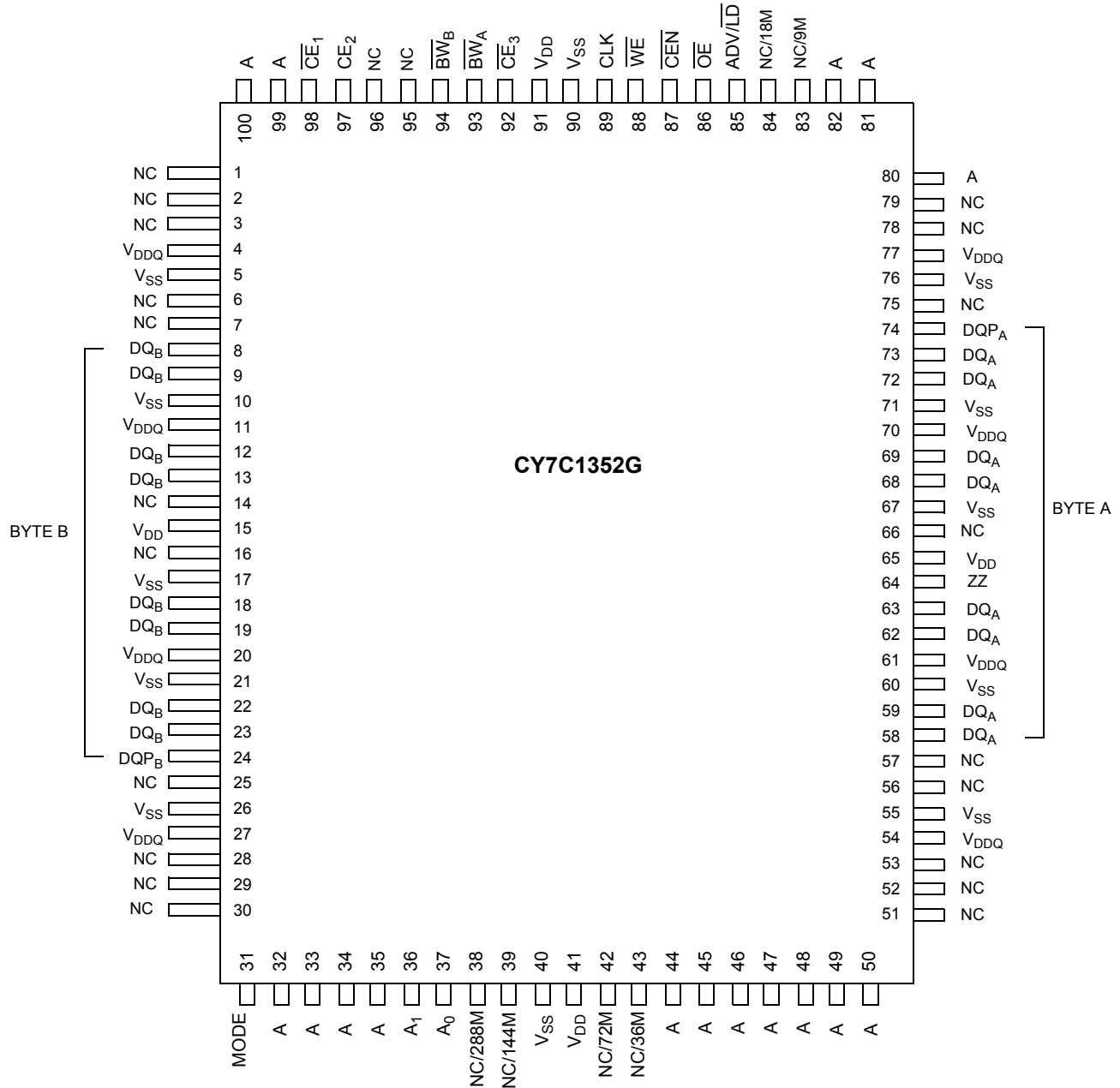

**Note**

1. **Errata:** The ZZ pin (Pin 64) needs to be externally connected to ground. For more information, see "Errata" on page 19.



## Pin Definitions

Name	I/O	Description
A <sub>0</sub> , A <sub>1</sub> , A	Input-synchronous	<b>Address inputs used to select one of the 256 K address location.</b> Sampled at the rising edge of the CLK. A <sub>[1:0]</sub> are fed to the two-bit burst counter.
BW <sub>[A:B]</sub>	Input-synchronous	<b>Byte write inputs, active LOW.</b> Qualified with WE to conduct writes to the SRAM. Sampled on the rising edge of CLK.
WE	Input-synchronous	<b>Write enable input, active LOW.</b> Sampled on the rising edge of CLK if CEN is active LOW. This signal must be asserted LOW to initiate a write sequence.
ADV/LD	Input-synchronous	<b>Advance/load input.</b> Used to advance the on-chip address counter or load a new address. When HIGH (and CEN is asserted LOW) the internal burst counter is advanced. When LOW, a new address can be loaded into the device for an access. After being deselected, ADV/LD should be driven LOW in order to load a new address.
CLK	Input-clock	<b>Clock input.</b> Used to capture all synchronous inputs to the device. CLK is qualified with CEN. CLK is only recognized if CEN is active LOW.
CE <sub>1</sub>	Input-synchronous	<b>Chip enable 1 input, active LOW.</b> Sampled on the rising edge of CLK. Used in conjunction with CE <sub>2</sub> and CE <sub>3</sub> to select/deselect the device.
CE <sub>2</sub>	Input-synchronous	<b>Chip enable 2 input, active HIGH.</b> Sampled on the rising edge of CLK. Used in conjunction with CE <sub>1</sub> and CE <sub>3</sub> to select/deselect the device.
CE <sub>3</sub>	Input-synchronous	<b>Chip enable 3 input, active LOW.</b> Sampled on the rising edge of CLK. Used in conjunction with CE <sub>1</sub> and CE <sub>2</sub> to select/deselect the device.
OE	Input-asynchronous	<b>Output enable, asynchronous input, active LOW.</b> Combined with the synchronous logic block inside the device to control the direction of the I/O pins. When LOW, the DQ pins are allowed to behave as outputs. When deasserted HIGH, DQ pins are tri-stated, and act as input data pins. OE is masked during the data portion of a write sequence, during the first clock when emerging from a deselected state, when the device has been deselected.
CEN	Input-synchronous	<b>Clock enable input, active LOW.</b> When asserted LOW the clock signal is recognized by the SRAM. When deasserted HIGH the clock signal is masked. Since deasserting CEN does not deselect the device, CEN can be used to extend the previous cycle when required.
ZZ <sup>[2]</sup>	Input-asynchronous	<b>ZZ "sleep" Input.</b> This active HIGH input places the device in a non-time-critical "sleep" condition with data integrity preserved. During normal operation, this pin has to be low or left floating. ZZ pin has an internal pull-down.
DQs	I/O-synchronous	<b>Bidirectional data I/O lines.</b> As inputs, they feed into an on-chip data register that is triggered by the rising edge of CLK. As outputs, they deliver the data contained in the memory location specified by the address during the clock rise of the read cycle. The direction of the pins is controlled by OE and the internal control logic. When OE is asserted LOW, the pins can behave as outputs. When HIGH, DQ <sub>s</sub> and DQP <sub>[A:B]</sub> are placed in a tri-state condition. The outputs are automatically tri-stated during the data portion of a write sequence, during the first clock when emerging from a deselected state, and when the device is deselected, regardless of the state of OE.

### Note

- Errata:** The ZZ pin (Pin 64) needs to be externally connected to ground. For more information, see "Errata" on page 19.



## Pin Definitions *(continued)*

Name	I/O	Description
DQP <sub>[A:B]</sub>	I/O-synchronous	<b>Bidirectional data parity I/O lines.</b> Functionally, these signals are identical to DQ <sub>s</sub> . During write sequences, DQP <sub>[A:B]</sub> is controlled by $\overline{BW}_{[A:B]}$ correspondingly.
MODE	Input strap pin	<b>Mode input.</b> Selects the burst order of the device. When tied to GND selects linear burst sequence. When tied to V <sub>DD</sub> or left floating selects interleaved burst sequence.
V <sub>DD</sub>	Power supply	<b>Power supply inputs to the core of the device.</b>
V <sub>DDQ</sub>	I/O power supply	<b>Power supply for the I/O circuitry.</b>
V <sub>SS</sub>	Ground	<b>Ground for the device.</b>
NC	–	<b>No Connects.</b> Not internally connected to the die.
NC/36M, NC/72M, NC/144M, NC/288M	–	<b>No Connects.</b> Not internally connected to the die. NC/36M, NC/72M, NC/144M, NC/288M are address expansion pins are not internally connected to the die.



## Functional Overview

The CY7C1352G is a synchronous-pipelined burst SRAM designed specifically to eliminate wait states during write/read transitions. All synchronous inputs pass through input registers controlled by the rising edge of the clock. The clock signal is qualified with the clock enable input signal ( $\overline{CEN}$ ). If  $\overline{CEN}$  is HIGH, the clock signal is not recognized and all internal states are maintained. All synchronous operations are qualified with  $\overline{CEN}$ . All data outputs pass through output registers controlled by the rising edge of the clock. Maximum access delay from the clock rise ( $t_{CO}$ ) is 4.0 ns (133-MHz device).

Accesses can be initiated by asserting all three chip enables ( $\overline{CE}_1$ ,  $\overline{CE}_2$ ,  $\overline{CE}_3$ ) active at the rising edge of the clock. If clock enable ( $\overline{CEN}$ ) is active LOW and  $\overline{ADV/LD}$  is asserted LOW, the address presented to the device will be latched. The access can either be a read or write operation, depending on the status of the write enable ( $\overline{WE}$ ).  $\overline{BW}_{[A:B]}$  can be used to conduct byte write operations.

Write operations are qualified by the write enable ( $\overline{WE}$ ). All writes are simplified with on-chip synchronous self-timed write circuitry.

Three synchronous chip enables ( $\overline{CE}_1$ ,  $\overline{CE}_2$ ,  $\overline{CE}_3$ ) and an asynchronous output enable ( $\overline{OE}$ ) simplify depth expansion. All operations (reads, writes, and deselections) are pipelined.  $\overline{ADV/LD}$  should be driven LOW once the device has been deselected in order to load a new address for the next operation.

### Single Read Accesses

A read access is initiated when the following conditions are satisfied at clock rise: (1)  $\overline{CEN}$  is asserted LOW, (2)  $\overline{CE}_1$ ,  $\overline{CE}_2$ , and  $\overline{CE}_3$  are all asserted active, (3) the write enable input signal  $\overline{WE}$  is deasserted HIGH, and (4)  $\overline{ADV/LD}$  is asserted LOW. The address presented to the address inputs is latched into the address register and presented to the memory core and control logic. The control logic determines that a read access is in progress and allows the requested data to propagate to the input of the output register. At the rising edge of the next clock the requested data is allowed to propagate through the output register and onto the data bus, provided  $\overline{OE}$  is active LOW. After the first clock of the read access the output buffers are controlled by  $\overline{OE}$  and the internal control logic.  $\overline{OE}$  must be driven LOW in order for the device to drive out the requested data. During the second clock, a subsequent operation (read/write/deselect) can be initiated. Deselecting the device is also pipelined. Therefore, when the SRAM is deselected at clock rise by one of the chip enable signals, its output will tri-state following the next clock rise.

### Burst Read Accesses

The CY7C1352G has an on-chip burst counter that allows the user the ability to supply a single address and conduct up to four reads without reasserting the address inputs.  $\overline{ADV/LD}$  must be driven LOW in order to load a new address into the SRAM, as described in the [Single Read Accesses](#) section above. The sequence of the burst counter is determined by the MODE input signal. A LOW input on MODE selects a linear burst mode, a

HIGH selects an interleaved burst sequence. Both burst counters use A0 and A1 in the burst sequence, and will wrap-around when incremented sufficiently. A HIGH input on  $\overline{ADV/LD}$  will increment the internal burst counter regardless of the state of chip enables inputs or  $\overline{WE}$ .  $\overline{WE}$  is latched at the beginning of a burst cycle. Therefore, the type of access (read or write) is maintained throughout the burst sequence.

### Single Write Accesses

Write accesses are initiated when the following conditions are satisfied at clock rise: (1)  $\overline{CEN}$  is asserted LOW, (2)  $\overline{CE}_1$ ,  $\overline{CE}_2$ , and  $\overline{CE}_3$  are all asserted active, and (3) the write signal  $\overline{WE}$  is asserted LOW. The address presented to the address inputs is loaded into the address register. The write signals are latched into the control logic block.

On the subsequent clock rise the data lines are automatically tri-stated regardless of the state of the  $\overline{OE}$  input signal. This allows the external logic to present the data on DQs and  $\overline{DQP}_{[A:B]}$ . In addition, the address for the subsequent access (read/write/deselect) is latched into the address register (provided the appropriate control signals are asserted).

On the next clock rise the data presented to DQs and  $\overline{DQP}_{[A:B]}$  (or a subset for byte write operations, see Write Cycle Description table for details) inputs is latched into the device and the write is complete.

The data written during the write operation is controlled by  $\overline{BW}_{[A:B]}$  signals. The CY7C1352G provides byte write capability that is described in the [Write Cycle Description](#) table. Asserting the write enable input ( $\overline{WE}$ ) with the selected byte write select ( $\overline{BW}_{[A:B]}$ ) input will selectively write to only the desired bytes. Bytes not selected during a byte write operation will remain unaltered. A synchronous self-timed write mechanism has been provided to simplify the write operations. Byte write capability has been included in order to greatly simplify read/modify/write sequences, which can be reduced to simple byte write operations.

Because the CY7C1352G is a common I/O device, data should not be driven into the device while the outputs are active. The output enable ( $\overline{OE}$ ) can be deasserted HIGH before presenting data to the DQs and  $\overline{DQP}_{[A:B]}$  inputs. Doing so will tri-state the output drivers. As a safety precaution, DQs and  $\overline{DQP}_{[A:B]}$  are automatically tri-stated during the data portion of a write cycle, regardless of the state of  $\overline{OE}$ .

### Burst Write Accesses

The CY7C1352G has an on-chip burst counter that allows the user the ability to supply a single address and conduct up to four write operations without reasserting the address inputs.  $\overline{ADV/LD}$  must be driven LOW in order to load the initial address, as described in the [Single Write Accesses](#) section above. When  $\overline{ADV/LD}$  is driven HIGH on the subsequent clock rise, the chip enables ( $\overline{CE}_1$ ,  $\overline{CE}_2$ , and  $\overline{CE}_3$ ) and  $\overline{WE}$  inputs are ignored and the burst counter is incremented. The correct  $\overline{BW}_{[A:B]}$  inputs must be driven in each cycle of the burst write in order to write the correct bytes of data.



## Sleep Mode

The ZZ input pin is an asynchronous input. Asserting ZZ places the SRAM in a power conservation “sleep” mode. Two clock cycles are required to enter into or exit from this “sleep” mode. While in this mode, data integrity is guaranteed. Accesses pending when entering the “sleep” mode are not considered valid nor is the completion of the operation guaranteed. The device must be deselected prior to entering the “sleep” mode. CE1, CE2, and CE3, must remain inactive for the duration of  $t_{ZZREC}$  after the ZZ input returns LOW.

## Interleaved Burst Address Table

(MODE = Floating or  $V_{DD}$ )

First Address A1:A0	Second Address A1:A0	Third Address A1:A0	Fourth Address A1:A0
00	01	10	11
01	00	11	10
10	11	00	01
11	10	01	00

## Linear Burst Address Table

(MODE = GND)

First Address A1:A0	Second Address A1:A0	Third Address A1:A0	Fourth Address A1:A0
00	01	10	11
01	10	11	00
10	11	00	01
11	00	01	10

## ZZ Mode Electrical Characteristics

Parameter	Description	Test Conditions	Min	Max	Unit
$I_{DDZZ}$	Snooze mode standby current	$ZZ \geq V_{DD} - 0.2 V$	–	40	mA
$t_{ZZS}$	Device operation to ZZ	$ZZ \geq V_{DD} - 0.2 V$	–	$2t_{CYC}$	ns
$t_{ZZREC}$	ZZ recovery time	$ZZ \leq 0.2 V$	$2t_{CYC}$	–	ns
$t_{ZZI}$	ZZ active to snooze current	This parameter is sampled	–	$2t_{CYC}$	ns
$t_{RZZI}$	ZZ inactive to exit snooze current	This parameter is sampled	0	–	ns



## Truth Table

The Truth Table for CY7C1352G follows. [3, 4, 5, 6, 7, 8, 9]

Operation	Address Used	$\overline{CE}$	ZZ	ADV/LD	$\overline{WE}$	$\overline{BW}_x$	$\overline{OE}$	$\overline{CEN}$	CLK	DQ
Deselect cycle	None	H	L	L	X	X	X	L	L-H	Tri-state
Continue deselect cycle	None	X	L	H	X	X	X	L	L-H	Tri-state
Read cycle (begin burst)	External	L	L	L	H	X	L	L	L-H	Data out (Q)
Read cycle (continue burst)	Next	X	L	H	X	X	L	L	L-H	Data out (Q)
NOP/dummy read (begin burst)	External	L	L	L	H	X	H	L	L-H	Tri-state
Dummy read (continue burst)	Next	X	L	H	X	X	H	L	L-H	Tri-state
Write cycle (begin burst)	External	L	L	L	L	L	X	L	L-H	Data in (D)
Write cycle (continue burst)	Next	X	L	H	X	L	X	L	L-H	Data in (D)
NOP/WRITE ABORT (begin burst)	None	L	L	L	L	H	X	L	L-H	Tri-state
WRITE ABORT (continue burst)	Next	X	L	H	X	H	X	L	L-H	Tri-state
IGNORE CLOCK EDGE (stall)	Current	X	L	X	X	X	X	H	L-H	-
SNOOZE MODE	None	X	H	X	X	X	X	X	X	Tri-state

### Notes

- X = "Don't Care." H = Logic HIGH, L = Logic LOW.  $\overline{CE}$  stands for all chip enables active.  $\overline{BW}_x = L$  signifies at least one byte write select is active,  $\overline{BW}_x = \text{valid}$  signifies that the desired byte write selects are asserted, see Write Cycle Description table for details.
- Write is defined by  $\overline{BW}_{[A:B]}$  and  $\overline{WE}$ . See Write Cycle Descriptions table.
- When a write cycle is detected, all I/Os are tri-stated, even during byte writes.
- The DQ and DQP pins are controlled by the current cycle and the  $\overline{OE}$  signal.  $\overline{OE}$  is asynchronous and is not sampled with the clock.
- $\overline{CEN} = H$ , inserts wait states.
- Device will power-up deselected and the I/Os in a tri-state condition, regardless of  $\overline{OE}$ .
- $\overline{OE}$  is asynchronous and is not sampled with the clock rise. It is masked internally during write cycles. During a read cycle DQs and  $DQP_{[A:B]}$  = tri-state when  $\overline{OE}$  is inactive or when the device is deselected, and DQs and  $DQP_{[A:B]}$  = data when  $\overline{OE}$  is active.



## Truth Table for Read/Write

The Truth Table for Read/Write for CY7C1352G follows. [10, 11]

Function	$\overline{WE}$	$\overline{BW}_B$	$\overline{BW}_A$
Read	H	X	X
Write – No bytes written	L	H	H
Write byte A – ( $DQ_A$ and $DQP_A$ )	L	H	L
Write byte B – ( $DQ_B$ and $DQP_B$ )	L	L	H
Write all bytes	L	L	L

### Notes

10. X = "Don't Care." H = Logic HIGH, L = Logic LOW.  $\overline{CE}$  stands for all chip enables active.  $\overline{BW}_X = L$  signifies at least one byte write select is active,  $\overline{BW}_X = \text{valid}$  signifies that the desired byte write selects are asserted, see Write Cycle Description table for details.

11. Write is defined by  $\overline{BW}_{[A:B]}$ , and  $\overline{WE}$ . See Write Cycle Descriptions table.



## Maximum Ratings

Exceeding maximum ratings may impair the useful life of the device. These user guidelines are not tested.

Storage temperature .....	-65 °C to +150 °C
Ambient temperature with power applied .....	-55 °C to +125 °C
Supply voltage on $V_{DD}$ relative to GND .....	-0.5 V to +4.6 V
Supply voltage on $V_{DDQ}$ relative to GND .....	-0.5 V to + $V_{DD}$
DC voltage applied to outputs in tri-state .....	-0.5 V to $V_{DDQ} + 0.5 V$

DC input voltage .....	-0.5 V to $V_{DD} + 0.5 V$
Current into outputs (LOW) .....	20 mA
Static discharge voltage (per MIL-STD-883, method 3015) .....	> 2001 V
Latch-up current .....	> 200 mA

## Operating Range

Range	Ambient Temperature ( $T_A$ )	$V_{DD}$	$V_{DDQ}$
Commercial	0 °C to +70 °C	3.3 V – 5% / +10%	2.5 V – 5% to $V_{DD}$

## Electrical Characteristics

Over the Operating Range

Parameter [12, 13]	Description	Test Conditions	Min	Max	Unit
$V_{DD}$	Power supply voltage		3.135	3.6	V
$V_{DDQ}$	I/O supply voltage		2.375	$V_{DD}$	V
$V_{OH}$	Output HIGH voltage	for 3.3 V I/O, $I_{OH} = -4.0$ mA	2.4	–	V
		for 2.5 V I/O, $I_{OH} = -1.0$ mA	2.0	–	V
$V_{OL}$	Output LOW voltage	for 3.3 V I/O, $I_{OL} = 8.0$ mA	–	0.4	V
		for 2.5 V I/O, $I_{OL} = 1.0$ mA	–	0.4	V
$V_{IH}$	Input HIGH voltage [12]	for 3.3 V I/O	2.0	$V_{DD} + 0.3 V$	V
		for 2.5 V I/O	1.7	$V_{DD} + 0.3 V$	V
$V_{IL}$	Input LOW voltage [12]	for 3.3 V I/O	-0.3	0.8	V
		for 2.5 V I/O	-0.3	0.7	V
$I_x$	Input leakage current except ZZ and MODE	$GND \leq V_I \leq V_{DDQ}$	-5	5	$\mu A$
	Input current of MODE	Input = $V_{SS}$	-30	–	$\mu A$
		Input = $V_{DD}$	–	5	$\mu A$
	Input current of ZZ	Input = $V_{SS}$	-5	–	$\mu A$
Input = $V_{DD}$		–	30	$\mu A$	
$I_{OZ}$	Output leakage current	$GND \leq V_I \leq V_{DDQ}$ , output disabled	-5	5	$\mu A$
$I_{DD}$	$V_{DD}$ operating supply current	$V_{DD} = \text{Max}$ , $I_{OUT} = 0$ mA, $f = f_{MAX} = 1/t_{CYC}$	–	225	mA
$I_{SB1}$	Automatic CE power-down current – TTL inputs	$V_{DD} = \text{Max}$ , device deselected, $V_{IN} \geq V_{IH}$ or $V_{IN} \leq V_{IL}$ , $f = f_{MAX} = 1/t_{CYC}$	–	90	mA
$I_{SB2}$	Automatic CE power-down current – CMOS inputs	$V_{DD} = \text{Max}$ , device deselected, $V_{IN} \leq 0.3 V$ or $V_{IN} \geq V_{DDQ} - 0.3 V$ , $f = 0$	–	40	mA
$I_{SB3}$	Automatic CE power-down current – CMOS Inputs	$V_{DD} = \text{Max}$ , device deselected, $V_{IN} \leq 0.3 V$ or $V_{IN} \geq V_{DDQ} - 0.3 V$ , $f = f_{MAX} = 1/t_{CYC}$	–	75	mA

### Notes

12. Overshoot:  $V_{IH(AC)} < V_{DD} + 1.5 V$  (Pulse width less than  $t_{CYC}/2$ ), undershoot:  $V_{IL(AC)} > -2 V$  (Pulse width less than  $t_{CYC}/2$ ).
13.  $T_{Power-up}$ : Assumes a linear ramp from 0 V to  $V_{DD(min)}$  within 200 ms. During this time  $V_{IH} < V_{DD}$  and  $V_{DDQ} \leq V_{DD}$ .

**Electrical Characteristics** (continued)

Over the Operating Range

Parameter <sup>[12, 13]</sup>	Description	Test Conditions	Min	Max	Unit
$I_{SB4}$	Automatic CE power-down current – TTL inputs	$V_{DD} = \text{Max}$ , device deselected, $V_{IN} \geq V_{IH}$ or $V_{IN} \leq V_{IL}$ , $f = 0$	–	45	mA

**Capacitance**

Parameter <sup>[14]</sup>	Description	Test Conditions	100-pin TQFP Max	Unit
$C_{IN}$	Input capacitance	$T_A = 25^\circ\text{C}$ , $f = 1\text{ MHz}$ , $V_{DD} = 3.3\text{ V}$ , $V_{DDQ} = 3.3\text{ V}$	5	pF
$C_{CLK}$	Clock input capacitance		5	pF
$C_{I/O}$	Input/output capacitance		5	pF

**Thermal Resistance**

Parameter <sup>[14]</sup>	Description	Test Conditions	100-pin TQFP Package	Unit
$\Theta_{JA}$	Thermal resistance (junction to ambient)	Test conditions follow standard test methods and procedures for measuring thermal impedance, per EIA/JESD51.	30.32	$^\circ\text{C/W}$
$\Theta_{JC}$	Thermal resistance (junction to case)		6.85	$^\circ\text{C/W}$

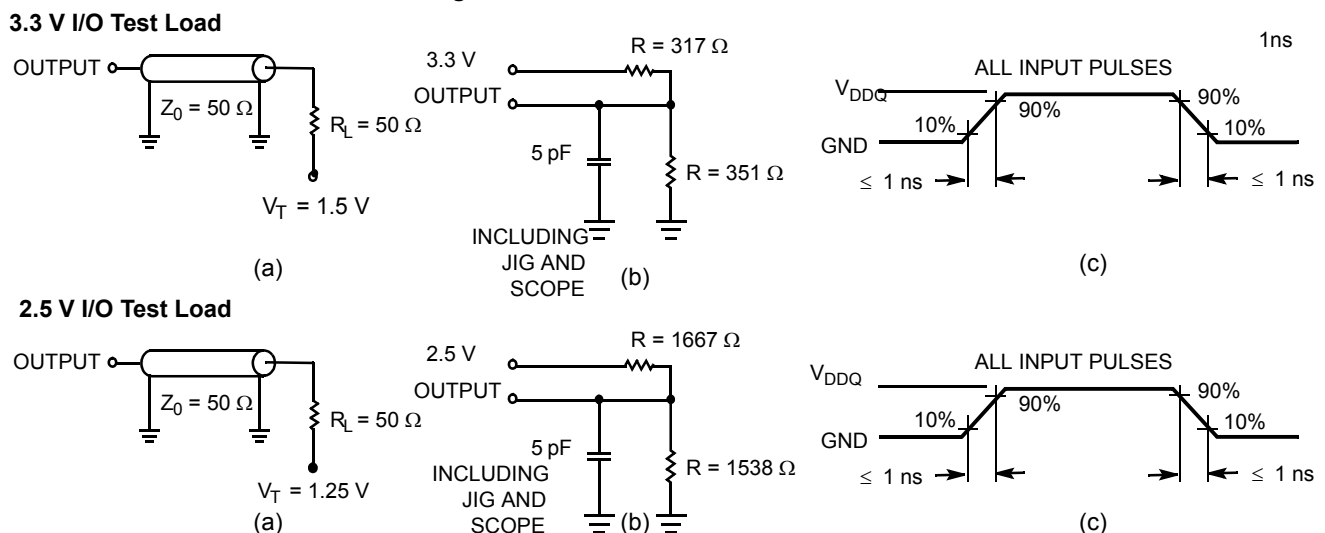
**AC Test Loads and Waveforms****Figure 2. AC Test Loads and Waveforms****Note**

14. Tested initially and after any design or process changes that may affect these parameters.



## Switching Characteristics

Over the Operating Range

Parameter <sup>[15, 16]</sup>	Description	-133		Unit
		Min	Max	
t <sub>POWER</sub>	V <sub>DD</sub> (typical) to the first access <sup>[17]</sup>	1	–	ms
<b>Clock</b>				
t <sub>CYC</sub>	Clock cycle time	7.5	–	ns
t <sub>CH</sub>	Clock HIGH	3.0	–	ns
t <sub>CL</sub>	Clock LOW	3.0	–	ns
<b>Output Times</b>				
t <sub>CO</sub>	Data output valid after CLK rise	–	4.0	ns
t <sub>DOH</sub>	Data output hold after CLK rise	1.5	–	ns
t <sub>CLZ</sub>	Clock to low Z <sup>[18, 19, 20]</sup>	0	–	ns
t <sub>CHZ</sub>	Clock to high Z <sup>[18, 19, 20]</sup>	–	4.0	ns
t <sub>OEV</sub>	$\overline{\text{OE}}$ LOW to output valid	–	4.0	ns
t <sub>OELZ</sub>	$\overline{\text{OE}}$ LOW to output low Z <sup>[18, 19, 20]</sup>	0	–	ns
t <sub>OEHZ</sub>	$\overline{\text{OE}}$ HIGH to output high Z <sup>[18, 19, 20]</sup>	–	4.0	ns
<b>Set-up Times</b>				
t <sub>AS</sub>	Address set-up before CLK rise	1.5	–	ns
t <sub>ALS</sub>	ADV/LD set-up before CLK rise	1.5	–	ns
t <sub>WES</sub>	$\overline{\text{GW}}$ , $\overline{\text{BW}}_{[\text{A:B}]}$ set-up before CLK rise	1.5	–	ns
t <sub>CENS</sub>	$\overline{\text{CEN}}$ set-up before CLK rise	1.5	–	ns
t <sub>DS</sub>	Data input set-up before CLK rise	1.5	–	ns
t <sub>CES</sub>	Chip enable set-up before CLK rise	1.5	–	ns
<b>Hold Times</b>				
t <sub>AH</sub>	Address hold after CLK rise	0.5	–	ns
t <sub>ALH</sub>	ADV/LD hold after CLK rise	0.5	–	ns
t <sub>WEH</sub>	$\overline{\text{GW}}$ , $\overline{\text{BW}}_{[\text{A:B}]}$ hold after CLK rise	0.5	–	ns
t <sub>CENH</sub>	$\overline{\text{CEN}}$ hold after CLK rise	0.5	–	ns
t <sub>DH</sub>	Data input hold after CLK rise	0.5	–	ns
t <sub>CEH</sub>	Chip enable hold after CLK rise	0.5	–	ns

### Notes

15. Timing reference level is 1.5 V when V<sub>DDQ</sub> = 3.3 V and is 1.25 V when V<sub>DDQ</sub> = 2.5 V.

16. Test conditions shown in (a) of Figure 2 on page 12 unless otherwise noted.

17. This part has a voltage regulator internally; t<sub>POWER</sub> is the time that the power needs to be supplied above V<sub>DD(minimum)</sub> initially before a read or write operation can be initiated.

18. t<sub>CHZ</sub>, t<sub>CLZ</sub>, t<sub>OELZ</sub>, and t<sub>OEHZ</sub> are specified with AC test conditions shown in part (b) of Figure 2 on page 12. Transition is measured ± 200 mV from steady-state voltage.

19. At any given voltage and temperature, t<sub>OEHZ</sub> is less than t<sub>OELZ</sub> and t<sub>CHZ</sub> is less than t<sub>CLZ</sub> to eliminate bus contention between SRAMs when sharing the same data bus. These specifications do not imply a bus contention condition, but reflect parameters guaranteed over worst case user conditions. Device is designed to achieve tri-state prior to low Z under the same system conditions.

20. This parameter is sampled and not 100% tested.

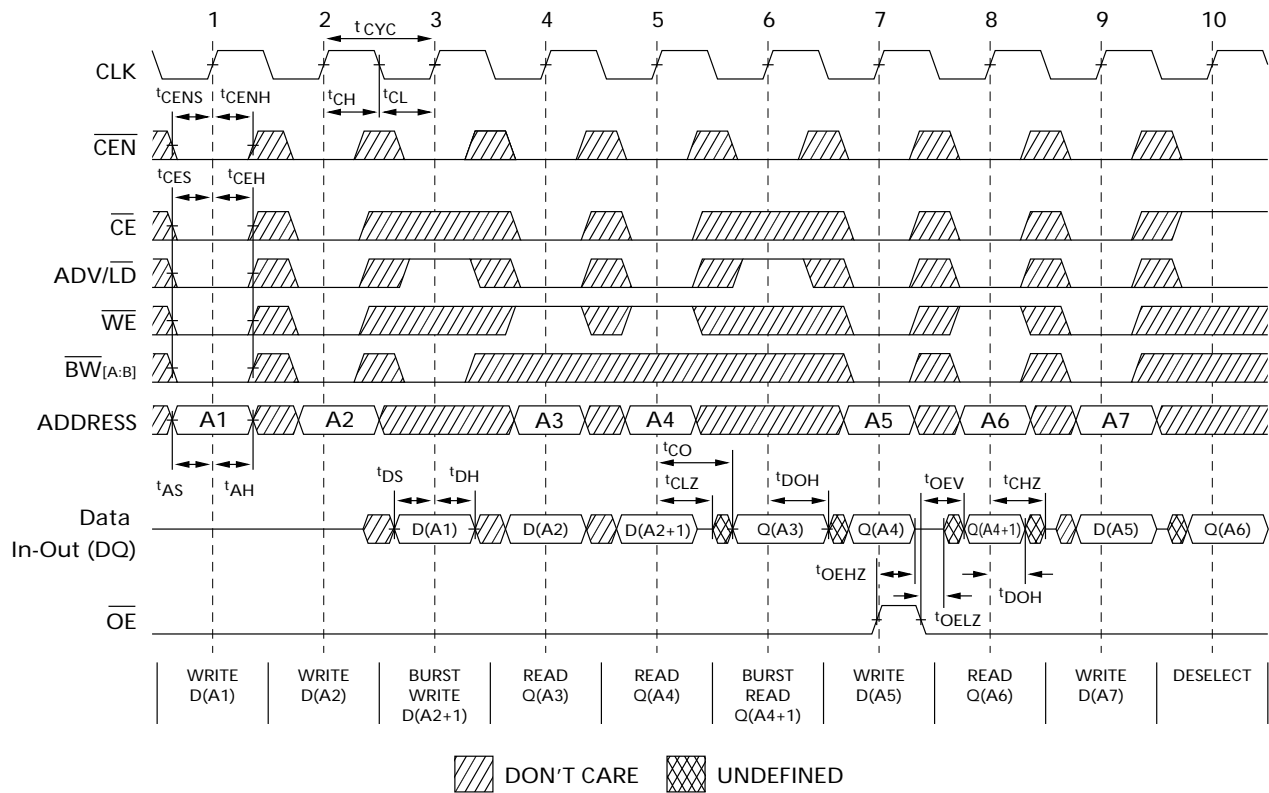
**Switching Waveforms****Figure 3. Read/Write Timing** [21, 22, 23]**Notes**

21. For this waveform, ZZ is tied low.

22. When  $\overline{CE}$  is LOW:  $\overline{CE}_1$  is LOW,  $CE_2$  is HIGH and  $\overline{CE}_3$  is LOW. When  $\overline{CE}$  is HIGH:  $\overline{CE}_1$  is HIGH or  $CE_2$  is LOW or  $\overline{CE}_3$  is HIGH.

23. Order of the burst sequence is determined by the status of the MODE (0 = Linear, 1 = Interleaved). Burst operations are optional.

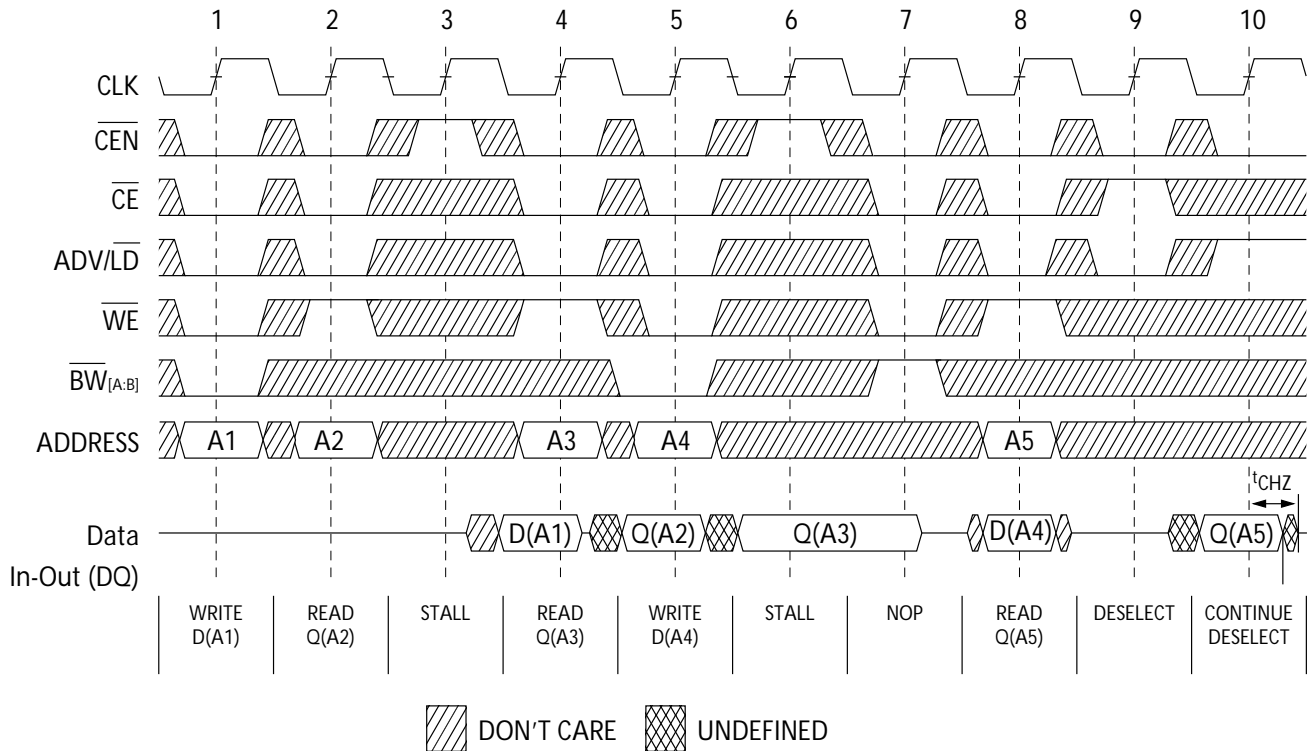
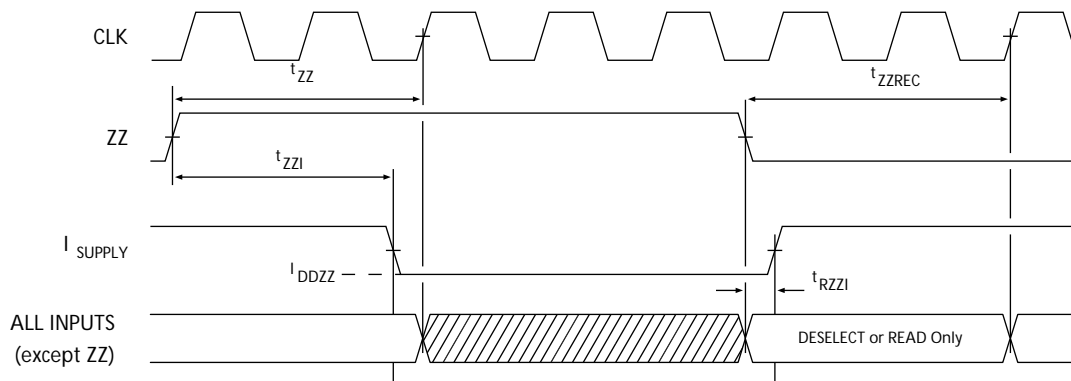
**Switching Waveforms** (continued)**Figure 4. NOP, STALL, and DESELECT Cycles** [24, 25, 26]**Figure 5. ZZ Mode Timing** [27, 28]**Notes**

24. For this waveform,  $\overline{ZZ}$  is tied low.

25. When  $\overline{CE}$  is LOW:  $\overline{CE}_1$  is LOW,  $\overline{CE}_2$  is HIGH and  $\overline{CE}_3$  is LOW. When  $\overline{CE}$  is HIGH:  $\overline{CE}_1$  is HIGH or  $\overline{CE}_2$  is LOW or  $\overline{CE}_3$  is HIGH.

26. The IGNORE CLOCK EDGE or STALL cycle (Clock 3) illustrated  $\overline{CEN}$  being used to create a pause. A write is not performed during this cycle.

27. Device must be deselected when entering ZZ mode. See cycle description table for all possible signal conditions to deselect the device.

28. DQs are in high Z when exiting ZZ sleep mode.



## Ordering Information

Cypress offers other versions of this type of product in many different configurations and features. The following table contains only the list of parts that are currently available.

For a complete listing of all options, visit the Cypress website at [www.cypress.com](http://www.cypress.com) and refer to the product summary page at <http://www.cypress.com/products> or contact your local sales representative.

Cypress maintains a worldwide network of offices, solution centers, manufacturer's representatives and distributors. To find the office closest to you, visit us at <http://www.cypress.com/go/datasheet/offices>.

Speed (MHz)	Ordering Code	Package Diagram	Package Type	Operating Range
133	CY7C1352G-133AXC	51-85050	100-pin TQFP (14 × 20 × 1.4 mm) Pb-free	Commercial

## Ordering Code Definitions

CY 7 C 1352 G - 133 A X C

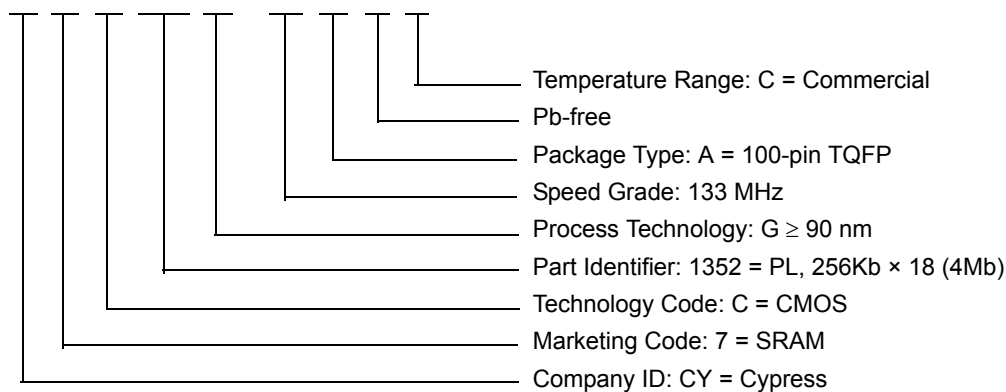

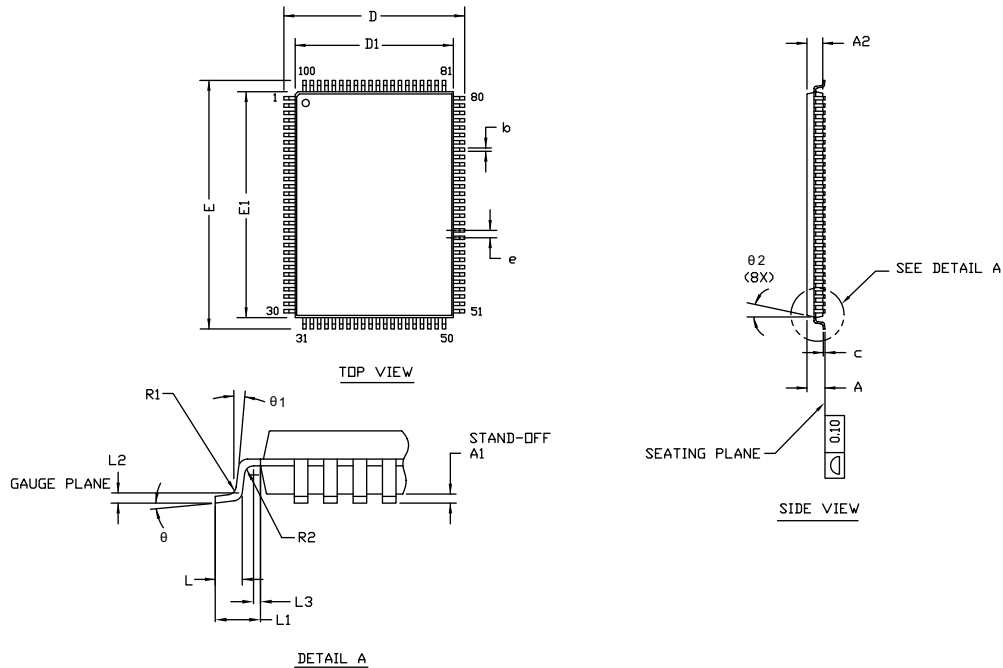
**Package Diagram****Figure 6. 100-pin TQFP (14 × 20 × 1.4 mm) A100RA Package Outline, 51-85050**

SYMBOL	DIMENSIONS		
	MIN.	NOM.	MAX.
A	—	—	1.60
A1	0.05	—	0.15
A2	1.35	1.40	1.45
D	15.80	16.00	16.20
D1	13.90	14.00	14.10
E	21.80	22.00	22.20
E1	19.90	20.00	20.10
R1	0.08	—	0.20
R2	0.08	—	0.20
θ	0°	—	7°
θ1	0°	—	—
θ2	11°	12°	13°
c	—	—	0.20
b	0.22	0.30	0.38
L	0.45	0.60	0.75
L1	1.00 REF		
L2	0.25 BSC		
L3	0.20	—	—
e	0.65 TYP		

**NOTE:**

- ALL DIMENSIONS ARE IN MILLIMETERS.
- BODY LENGTH DIMENSION DOES NOT INCLUDE MOLD PROTRUSION/END FLASH. MOLD PROTRUSION/END FLASH SHALL NOT EXCEED 0.0098 in (0.25 mm) PER SIDE. BODY LENGTH DIMENSIONS ARE MAX PLASTIC BODY SIZE INCLUDING MOLD MISMATCH.
- JEDEC SPECIFICATION NO. REF: MS-026.

51-85050 \*F



## Acronyms

Acronym	Description
$\overline{CE}$	Chip Enable
$\overline{CEN}$	Clock Enable
CMOS	Complementary Metal Oxide Semiconductor
EIA	Electronic Industries Alliance
I/O	Input/Output
JEDEC	Joint Electron Devices Engineering Council
NoBL	No Bus Latency
$\overline{OE}$	Output Enable
SEL	Single Event Latch-up
SRAM	Static Random Access Memory
TQFP	Thin Quad Flat Pack
TTL	Transistor-Transistor Logic
$\overline{WE}$	Write Enable

## Document Conventions

### Units of Measure

Symbol	Unit of Measure
$^{\circ}\text{C}$	degree Celsius
MHz	megahertz
$\mu\text{A}$	microampere
mA	milliampere
mm	millimeter
ms	millisecond
mV	millivolt
nm	nanometer
ns	nanosecond
$\Omega$	ohm
%	percent
pF	picofarad
V	volt
W	watt



## Errata

This section describes the Ram9 NoBL ZZ pin issue. Details include trigger conditions, the devices affected, proposed workaround and silicon revision applicability. Please contact your local Cypress sales representative if you have further questions.

### Part Numbers Affected

Density & Revision	Package Type	Operating Range
4Mb-Ram9 NoBL™ SRAMs: CY7C135*G	100-pin TQFP	Commercial

### Product Status

All of the devices in the Ram9 4Mb NoBL family are qualified and available in production quantities.

### Ram9 NoBL ZZ Pin Issues Errata Summary

The following table defines the errata applicable to available Ram9 4Mb NoBL family devices.

Item	Issues	Description	Device	Fix Status
1.	ZZ Pin	When asserted HIGH, the ZZ pin places device in a “sleep” condition with data integrity preserved. The ZZ pin currently does not have an internal pull-down resistor and hence cannot be left floating externally by the user during normal mode of operation.	4M-Ram9 (90nm)	For the 4M Ram9 (90 nm) devices, there is no plan to fix this issue.

#### 1. ZZ Pin Issue

##### ■ PROBLEM DEFINITION

The problem occurs only when the device is operated in the normal mode with ZZ pin left floating. The ZZ pin on the SRAM device does not have an internal pull-down resistor. Switching noise in the system may cause the SRAM to recognize a HIGH on the ZZ input, which may cause the SRAM to enter sleep mode. This could result in incorrect or undesirable operation of the SRAM.

##### ■ TRIGGER CONDITIONS

Device operated with ZZ pin left floating.

##### ■ SCOPE OF IMPACT

When the ZZ pin is left floating, the device delivers incorrect data.

##### ■ WORKAROUND

Tie the ZZ pin externally to ground.

##### ■ FIX STATUS

For the 4M Ram9 (90 nm) devices, there is no plan to fix this issue.

**Document History Page**

<b>Document Title: CY7C1352G, 4-Mbit (256K × 18) Pipelined SRAM with NoBL™ Architecture</b>				
<b>Document Number: 38-05514</b>				
<b>Rev.</b>	<b>ECN No.</b>	<b>Issue Date</b>	<b>Orig. of Change</b>	<b>Description of Change</b>
**	224362	See ECN	RKF	New data sheet.
*A	288431	See ECN	VBL	Updated <a href="#">Features</a> (Removed 225 MHz, 100 MHz frequencies related information). Updated <a href="#">Selection Guide</a> (Removed 225 MHz, 100 MHz frequencies related information). Updated <a href="#">Electrical Characteristics</a> (Removed 225 MHz, 100 MHz frequencies related information). Updated <a href="#">Switching Characteristics</a> (Removed 225 MHz, 100 MHz frequencies related information). Updated <a href="#">Ordering Information</a> (Changed TQFP package in Ordering Information section to lead-free TQFP).
*B	332895	See ECN	SYT	Updated <a href="#">Pin Configuration</a> (Modified Address Expansion balls in the pinouts for 100-pin TQFP Package as per JEDEC standards). Updated <a href="#">Pin Definitions</a> . Updated <a href="#">Electrical Characteristics</a> (Updated Test Conditions of $V_{OL}$ , $V_{OH}$ parameters). Updated <a href="#">Thermal Resistance</a> (Replaced values of $\Theta_{JA}$ and $\Theta_{JC}$ parameters from TBD to respective Thermal Values for all Packages). Updated <a href="#">Ordering Information</a> (By shading and unshading MPNs as per availability, added lead-free product information for 119-ball BGA).
*C	419256	See ECN	RXU	Changed status from Preliminary to Final. Changed address of Cypress Semiconductor Corporation from "3901 North First Street" to "198 Champion Court". Updated <a href="#">Electrical Characteristics</a> (Updated Note 13 (Modified test condition from $V_{IH} \leq V_{DD}$ to $V_{IH} < V_{DD}$ , modified test condition from $V_{DDQ} < V_{DD}$ to $V_{DDQ} \leq V_{DD}$ ), changed "Input Load Current except ZZ and MODE" to "Input Leakage Current except ZZ and MODE"). Updated <a href="#">Ordering Information</a> (Updated part numbers, replaced Package Name column with Package Diagram in the Ordering Information table). Updated <a href="#">Package Diagram</a> (spec 51-85050 (changed revision from *A to *B)).
*D	480124	See ECN	VKN	Updated <a href="#">Maximum Ratings</a> (Added the Maximum Rating for Supply Voltage on $V_{DDQ}$ Relative to GND). Updated <a href="#">Ordering Information</a> (Updated part numbers).
*E	2896584	03/20/2010	NJY	Updated <a href="#">Ordering Information</a> (Removed obsolete part numbers from Ordering Information table). Updated <a href="#">Package Diagram</a> .
*F	3023558	09/14/2010	NJY	Added <a href="#">Ordering Code Definitions</a> under <a href="#">Ordering Information</a> . Added <a href="#">Acronyms and Units of Measure</a> . Minor edits. Updated to new template.
*G	3052777	10/08/10	NJY	Updated <a href="#">Ordering Information</a> (Removed pruned part CY7C1352G-133AXI).
*H	3370121	09/13/2011	PRIT	Updated <a href="#">Package Diagram</a> .



## Document History Page *(continued)*

Document Title: CY7C1352G, 4-Mbit (256K × 18) Pipelined SRAM with NoBL™ Architecture Document Number: 38-05514				
Rev.	ECN No.	Issue Date	Orig. of Change	Description of Change
*I	3616656	05/14/2012	PRIT	Updated <a href="#">Features</a> (Removed 250 MHz, 200 MHz, 166 MHz frequencies related information). Updated <a href="#">Functional Description</a> (Removed the Note “For best-practices recommendations, refer to the Cypress application note <i>System Design Guidelines</i> on <a href="http://www.cypress.com">www.cypress.com</a> .” and its reference). Updated <a href="#">Selection Guide</a> (Removed 250 MHz, 200 MHz, 166 MHz frequencies related information). Updated <a href="#">Functional Overview</a> (Removed 250 MHz, 200 MHz, 166 MHz frequencies related information). Updated <a href="#">Operating Range</a> (Removed Industrial Temperature Range). Updated <a href="#">Electrical Characteristics</a> (Removed 250 MHz, 200 MHz, 166 MHz frequencies related information). Updated <a href="#">Switching Characteristics</a> (Removed 250 MHz, 200 MHz, 166 MHz frequencies related information).
*J	3751125	09/21/2012	PRIT	No technical updates. Completing Sunset Review.
*K	3980362	04/24/2013	PRIT	Added <a href="#">Errata</a> .
*L	4038283	06/24/2013	PRIT	Added Errata Footnotes. Updated to new template.
*M	4149033	10/07/2013	PRIT	Updated <a href="#">Errata</a> .
*N	4574263	11/19/2014	PRIT	Updated <a href="#">Functional Description</a> : Added “For a complete list of related documentation, click <a href="#">here</a> .” at the end. Updated package diagram.
*O	5508643	11/03/2016	PRIT	Updated <a href="#">Package Diagram</a> : spec 51-85050 – Changed revision from *E to *F. Updated to new template. Completing Sunset Review.



## Sales, Solutions, and Legal Information

### Worldwide Sales and Design Support

Cypress maintains a worldwide network of offices, solution centers, manufacturer's representatives, and distributors. To find the office closest to you, visit us at [Cypress Locations](#).

#### Products

ARM® Cortex® Microcontrollers	<a href="http://cypress.com/arm">cypress.com/arm</a>
Automotive	<a href="http://cypress.com/automotive">cypress.com/automotive</a>
Clocks & Buffers	<a href="http://cypress.com/clocks">cypress.com/clocks</a>
Interface	<a href="http://cypress.com/interface">cypress.com/interface</a>
Internet of Things	<a href="http://cypress.com/iot">cypress.com/iot</a>
Lighting & Power Control	<a href="http://cypress.com/powerpsoc">cypress.com/powerpsoc</a>
Memory	<a href="http://cypress.com/memory">cypress.com/memory</a>
PSoC	<a href="http://cypress.com/psoc">cypress.com/psoc</a>
Touch Sensing	<a href="http://cypress.com/touch">cypress.com/touch</a>
USB Controllers	<a href="http://cypress.com/usb">cypress.com/usb</a>
Wireless/RF	<a href="http://cypress.com/wireless">cypress.com/wireless</a>

#### PSoC® Solutions

[PSoC 1](#) | [PSoC 3](#) | [PSoC 4](#) | [PSoC 5LP](#)

#### Cypress Developer Community

[Forums](#) | [Projects](#) | [Video](#) | [Blogs](#) | [Training](#) | [Components](#)

#### Technical Support

[cypress.com/support](http://cypress.com/support)

© Cypress Semiconductor Corporation, 2004-2016. This document is the property of Cypress Semiconductor Corporation and its subsidiaries, including Spansion LLC ("Cypress"). This document, including any software or firmware included or referenced in this document ("Software"), is owned by Cypress under the intellectual property laws and treaties of the United States and other countries worldwide. Cypress reserves all rights under such laws and treaties and does not, except as specifically stated in this paragraph, grant any license under its patents, copyrights, trademarks, or other intellectual property rights. If the Software is not accompanied by a license agreement and you do not otherwise have a written agreement with Cypress governing the use of the Software, then Cypress hereby grants you a personal, non-exclusive, nontransferable license (without the right to sublicense) (1) under its copyright rights in the Software (a) for Software provided in source code form, to modify and reproduce the Software solely for use with Cypress hardware products, only internally within your organization, and (b) to distribute the Software in binary code form externally to end users (either directly or indirectly through resellers and distributors), solely for use on Cypress hardware product units, and (2) under those claims of Cypress's patents that are infringed by the Software (as provided by Cypress, unmodified) to make, use, distribute, and import the Software solely for use with Cypress hardware products. Any other use, reproduction, modification, translation, or compilation of the Software is prohibited.

TO THE EXTENT PERMITTED BY APPLICABLE LAW, CYPRESS MAKES NO WARRANTY OF ANY KIND, EXPRESS OR IMPLIED, WITH REGARD TO THIS DOCUMENT OR ANY SOFTWARE OR ACCOMPANYING HARDWARE, INCLUDING, BUT NOT LIMITED TO, THE IMPLIED WARRANTIES OF MERCHANTABILITY AND FITNESS FOR A PARTICULAR PURPOSE. To the extent permitted by applicable law, Cypress reserves the right to make changes to this document without further notice. Cypress does not assume any liability arising out of the application or use of any product or circuit described in this document. Any information provided in this document, including any sample design information or programming code, is provided only for reference purposes. It is the responsibility of the user of this document to properly design, program, and test the functionality and safety of any application made of this information and any resulting product. Cypress products are not designed, intended, or authorized for use as critical components in systems designed or intended for the operation of weapons, weapons systems, nuclear installations, life-support devices or systems, other medical devices or systems (including resuscitation equipment and surgical implants), pollution control or hazardous substances management, or other uses where the failure of the device or system could cause personal injury, death, or property damage ("Unintended Uses"). A critical component is any component of a device or system whose failure to perform can be reasonably expected to cause the failure of the device or system, or to affect its safety or effectiveness. Cypress is not liable, in whole or in part, and you shall and hereby do release Cypress from any claim, damage, or other liability arising from or related to all Unintended Uses of Cypress products. You shall indemnify and hold Cypress harmless from and against all claims, costs, damages, and other liabilities, including claims for personal injury or death, arising from or related to any Unintended Uses of Cypress products.

Cypress, the Cypress logo, Spansion, the Spansion logo, and combinations thereof, WICED, PSoC, CapSense, EZ-USB, F-RAM, and Traveo are trademarks or registered trademarks of Cypress in the United States and other countries. For a more complete list of Cypress trademarks, visit [cypress.com](http://cypress.com). Other names and brands may be claimed as property of their respective owners.

## OUR CERTIFICATE

DiGi provide top-quality products and perfect service for customer worldwide through standardization, technological innovation and continuous improvement. DiGi through third-party certification, we strictly control the quality of products and services. Welcome your RFQ to

Email: [Info@DiGi-Electronics.com](mailto:Info@DiGi-Electronics.com)



Tel: +00 852-30501935

RFQ Email: [Info@DiGi-Electronics.com](mailto:Info@DiGi-Electronics.com)

DiGi is a global authorized distributor of electronic components.