

CY7C1399BNL-12ZXC Datasheet

www.digi-electronics.com



<https://www.DiGi-Electronics.com>

DiGi Electronics Part Number	CY7C1399BNL-12ZXC-DG
Manufacturer	Infineon Technologies
Manufacturer Product Number	CY7C1399BNL-12ZXC
Description	IC SRAM 256KBIT PAR 28TSOP I
Detailed Description	SRAM - Asynchronous Memory IC 256Kbit Parallel 1 2 ns 28-TSOP I

This model CY7C1399BNL-12ZXC is available at DiGi Electronics.

DiGi Electronics offers a global database of semiconductor and electronic component datasheets.

We welcome your inquiries regarding pricing, lead time, or other product-related questions.

 [Request a Quote](#)

 [Datasheet Search](#)



Tel: +00 852-30501935

RFQ Email: Info@DiGi-Electronics.com

DiGi is a global authorized distributor of electronic components.

Purchase and inquiry

Manufacturer Product Number:

CY7C1399BNL-12ZXC

Series:

-

DiGi-Electronics Programmable:

Not Verified

Memory Format:

SRAM

Memory Size:

256Kbit

Memory Interface:

Parallel

Access Time:

12 ns

Operating Temperature:

0°C ~ 70°C (TA)

Package / Case:

28-TSSOP (0.465", 11.80mm Width)

Base Product Number:

CY7C1399

Manufacturer:

Infineon Technologies

Product Status:

Obsolete

Memory Type:

Volatile

Technology:

SRAM - Asynchronous

Memory Organization:

32K x 8

Write Cycle Time - Word, Page:

12ns

Voltage - Supply:

3V ~ 3.6V

Mounting Type:

Surface Mount

Supplier Device Package:

28-TSOP I

Environmental & Export classification

RoHS Status:

ROHS3 Compliant

REACH Status:

REACH Unaffected

HTSUS:

8542.32.0041

Moisture Sensitivity Level (MSL):

3 (168 Hours)

ECCN:

EAR99



CY7C1399BN

256-Kbit (32 K × 8) Static RAM

Features

- Temperature Ranges
 - Industrial: -40 °C to 85 °C
 - Commercial: 0 °C to 70 °C
 - Automotive-A: -40 °C to 85 °C
- Single 3.3 V power supply
- Ideal for low-voltage cache memory applications
- High speed: 12 ns
- Low active power
 - 180 mW (max)
- Low-power alpha immune 6T cell
- Available in pb-free and non pb-free plastic SOJ and TSOP-1 packages

Functional Description

The CY7C1399BN is a high-performance 3.3 V CMOS Static RAM organized as 32,768 words by 8 bits. Easy memory expansion is provided by an active LOW Chip Enable (\overline{CE}) and active LOW Output Enable (\overline{OE}) and tristate drivers. The device has an automatic power-down feature, reducing the power consumption by more than 95% when deselected.

An active LOW Write Enable signal (\overline{WE}) controls the writing/reading operation of the memory. When \overline{CE} and \overline{WE} inputs are both LOW, data on the eight data input/output pins (I/O_0 through I/O_7) is written into the memory location addressed by the address present on the address pins (A_0 through A_{14}). Reading the device is accomplished by selecting the device and enabling the outputs, \overline{CE} and \overline{OE} active LOW, while \overline{WE} remains inactive or HIGH. Under these conditions, the contents of the location addressed by the information on address pins is present on the eight data input/output pins.

The input/output pins remain in a high-impedance state unless the chip is selected, outputs are enabled, and Write Enable (\overline{WE}) is HIGH. The CY7C1399BN is available in 28-pin standard 300-mil-wide SOJ and TSOP Type I packages.

For a complete list of related documentation, click [here](#).

Logic Block Diagram

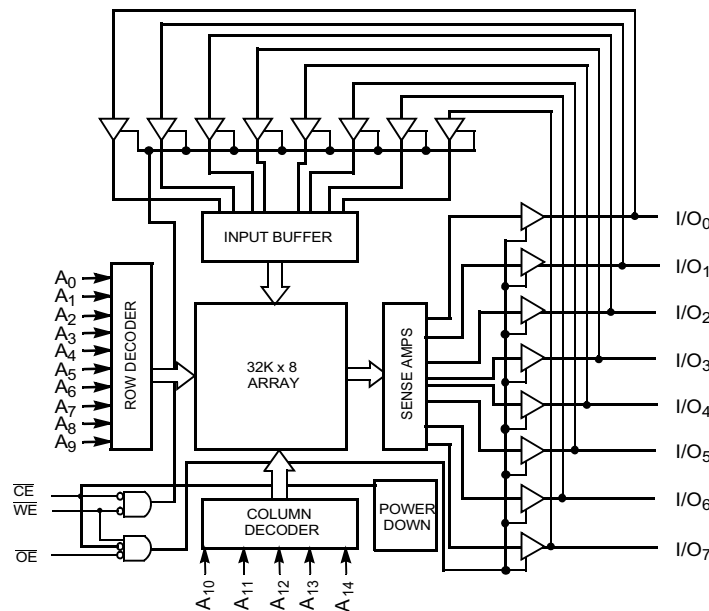



Contents

Pin Configurations	3	Package Diagrams	12
Selection Guide	3	Acronyms	14
Maximum Ratings	4	Document Conventions	14
Operating Range	4	Units of Measure	14
Electrical Characteristics	4	Document History Page	15
Capacitance	5	Sales, Solutions, and Legal Information	16
AC Test Loads and Waveforms	5	Worldwide Sales and Design Support	16
Data Retention Characteristics	5	Products	16
Data Retention Waveform	5	PSoC® Solutions	16
Switching Characteristics	6	Cypress Developer Community	16
Switching Waveforms	7	Technical Support	16
Truth Table	10		
Ordering Information	11		
Ordering Code Definitions	11		

Pin Configurations

Figure 1. 28-pin TSOP pinout (Top View)

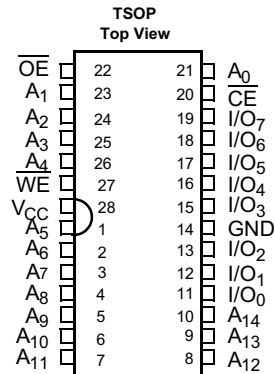
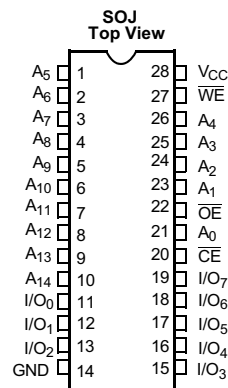

Figure 2. 28-pin SOJ pinout (Top View)



Selection Guide

Description	Condition	-12	-15
Maximum access time (ns)		12	15
Maximum operating current (mA)		55	50
Maximum CMOS standby current (μ A)	Commercial	500	–
	Commercial (L)	50	–
	Industrial	500	500
	Automotive-A	–	500



Maximum Ratings

Exceeding maximum ratings may shorten the useful life of the device. User guidelines are not tested.

Storage temperature	-65 °C to +150 °C
Ambient temperature with power applied	-55 °C to +125 °C
Supply voltage on V_{CC} to relative GND ^[1]	-0.5 V to +4.6 V
DC voltage applied to outputs in high Z State ^[1]	-0.5 V to $V_{CC} + 0.5$ V
DC input voltage ^[1]	-0.5 V to $V_{CC} + 0.5$ V

Output current into outputs (LOW)	20 mA
Static discharge voltage (per MIL-STD-883, Method 3015)	>2001 V
Latch-up current	>200 mA

Operating Range

Range	Ambient Temperature	V_{CC}
Commercial	0 °C to +70 °C	3.3 V ± 300 mV
Industrial	-40 °C to +85 °C	
Automotive-A	-40 °C to +85 °C	

Electrical Characteristics

Over the Operating Range

Parameter ^[1]	Description	Test Conditions	-12		-15		Unit	
			Min	Max	Min	Max		
V_{OH}	Output HIGH voltage	Min V_{CC} , $I_{OH} = -2.0$ mA	2.4	-	2.4	-	V	
V_{OL}	Output LOW voltage	Min V_{CC} , $I_{OL} = 4.0$ mA	-	0.4	-	0.4	V	
V_{IH}	Input HIGH voltage		2.2	$V_{CC} + 0.3$	2.2	$V_{CC} + 0.3$	V	
V_{IL} ^[1]	Input LOW voltage		-0.3	0.8	-0.3	0.8	V	
I_{IX}	Input leakage current		-1	+1	-1	+1	μA	
I_{OZ}	Output leakage current	$GND \leq V_{IN} \leq V_{CC}$, Output disabled	-5	+5	-5	+5	μA	
I_{CC}	V_{CC} operating supply current	Max V_{CC} , $I_{OUT} = 0$ mA, $f = f_{MAX} = 1/t_{RC}$	-	55	-	50	mA	
I_{SB1}	Automatic CE power-down current – TTL inputs	Max V_{CC} , $\overline{CE} \geq V_{IH}$, $V_{IN} \geq V_{IH}$, or $V_{IN} \leq V_{IL}$, $f = f_{MAX}$	Commercial	-	5	-	-	mA
			Commercial (L)	-	4	-	-	mA
			Industrial	-	5	-	5	mA
			Automotive-A	-	-	-	5	mA
I_{SB2}	Automatic CE Power-down current – CMOS inputs ^[2]	Max V_{CC} , $\overline{CE} \geq V_{CC} - 0.3$ V, $V_{IN} \geq V_{CC} - 0.3$ V, or $V_{IN} \leq 0.3$ V, $WE \geq V_{CC} - 0.3$ V or $WE \leq 0.3$ V, $f = f_{MAX}$	Commercial	-	500	-	-	μA
			Commercial (L)	-	50	-	-	μA
			Industrial	-	500	-	500	μA
			Automotive-A	-	-	-	500	μA

Notes

1. Minimum voltage is equal to -2.0 V for pulse durations of less than 20 ns.
2. Device draws low standby current regardless of switching on the addresses.

Capacitance

Parameter ^[3]	Description	Test Conditions	Max	Unit
C_{IN} : Addresses	Input capacitance	$T_A = 25^\circ\text{C}$, $f = 1\text{ MHz}$, $V_{CC} = 3.3\text{ V}$	5	pF
C_{IN} : Controls			6	pF
C_{OUT}	Output capacitance		6	pF

AC Test Loads and Waveforms

Figure 3. AC Test Loads and Waveforms ^[4]

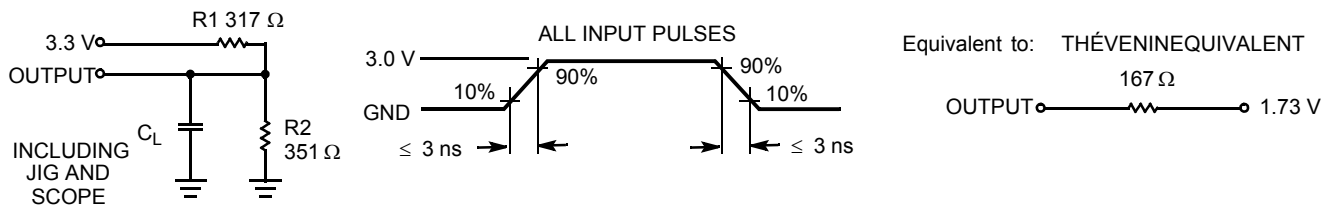

Data Retention Characteristics

(Over the Operating Range - L version only)

Parameter	Description	Conditions	Min	Max	Unit
V_{DR}	V_{CC} for data retention		2.0	–	V
I_{CCDR}	Data retention current	$V_{CC} = V_{DR} = 2.0\text{ V}$, $CE \geq V_{CC} - 0.3\text{ V}$, $V_{IN} \geq V_{CC} - 0.3\text{ V}$ or $V_{IN} \leq 0.3\text{ V}$	0	20	μA
t_{CDR}	Chip deselect to data retention time		0	–	ns
t_R	Operation recovery time		t_{RC}	–	ns

Data Retention Waveform

Figure 4. Data Retention Waveform

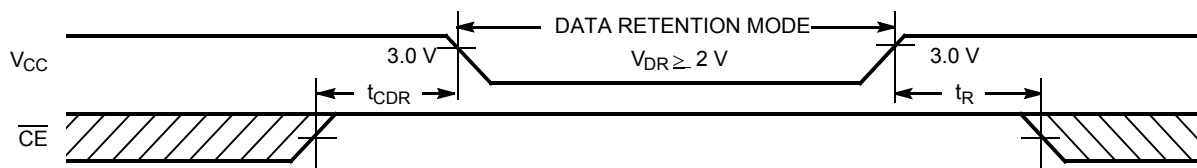

Notes

- Tested initially and after any design or process changes that may affect these parameters.
- Test conditions assume signal transition time of 3 ns or less, timing reference levels of 1.5 V, input pulse levels of 0 to 3.0 V, and output loading of the specified I_{OL}/I_{OH} and capacitance $C_L = 30\text{ pF}$.



Switching Characteristics

Over the Operating Range

Parameter ^[5]	Description	-12		-15		Unit
		Min	Max	Min	Max	
Read Cycle						
t_{RC}	Read cycle time	12	–	15	–	ns
t_{AA}	Address to data valid	–	12	–	15	ns
t_{OHA}	Data hold from address change	3	–	3	–	ns
t_{ACE}	\overline{CE} LOW to data valid	–	12	–	15	ns
t_{DOE}	\overline{OE} LOW to data valid	–	5	–	6	ns
t_{LZOE}	\overline{OE} LOW to low Z ^[6]	0	–	0	–	ns
t_{HZOE}	\overline{OE} HIGH to high Z ^[6, 7]	–	5	–	6	ns
t_{LZCE}	\overline{CE} LOW to low Z ^[6]	3	–	3	–	ns
t_{HZCE}	\overline{CE} HIGH to high Z ^[6, 7]	–	6	–	7	ns
t_{PU}	\overline{CE} LOW to power-up	0	–	0	–	ns
t_{PD}	\overline{CE} HIGH to power-down	–	12	–	15	ns
Write Cycle ^[8, 9]						
t_{WC}	Write cycle time	12	–	15	–	ns
t_{SCE}	\overline{CE} LOW to write end	8	–	10	–	ns
t_{AW}	Address setup to write end	8	–	10	–	ns
t_{HA}	Address hold from write end	0	–	0	–	ns
t_{SA}	Address setup to write start	0	–	0	–	ns
t_{PWE}	\overline{WE} pulse width	8	–	10	–	ns
t_{SD}	Data setup to write end	7	–	8	–	ns
t_{HD}	Data hold from write end	0	–	0	–	ns
t_{HZWE}	\overline{WE} low to high Z ^[8]	–	7	–	7	ns
t_{LZWE}	\overline{WE} high to low Z ^[6]	3	–	3	–	ns

Notes

- Test conditions assume signal transition time of 3 ns or less, timing reference levels of 1.5 V, input pulse levels of 0 to 3.0 V, and output loading of the specified I_{OL}/I_{OH} and capacitance $C_L = 30$ pF.
- At any given temperature and voltage condition, t_{HZCE} is less than t_{LZCE} , t_{HZOE} is less than t_{LZOE} , and t_{HZWE} is less than t_{LZWE} for any given device.
- t_{HZOE} , t_{HZCE} , t_{HZWE} are specified with $C_L = 5$ pF as in AC Test Loads. Transition is measured ± 500 mV from steady state voltage.
- The internal write time of the memory is defined by the overlap of \overline{CE} LOW and \overline{WE} LOW. Both signals must be LOW to initiate a write and either signal can terminate a write by going HIGH. The data input set-up and hold timing should be referenced to the rising edge of the signal that terminates the write.
- The minimum write cycle time for Write Cycle No. 3 (\overline{WE} Controlled, \overline{OE} LOW) is the sum of t_{HZWE} and t_{SD} .

Switching Waveforms

Figure 5. Read Cycle No. 1 [10, 11]

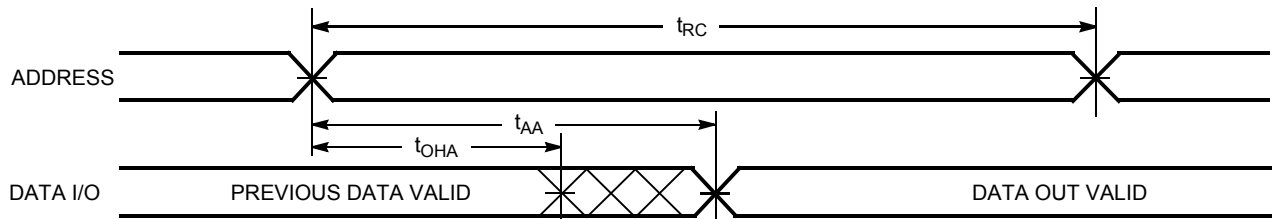
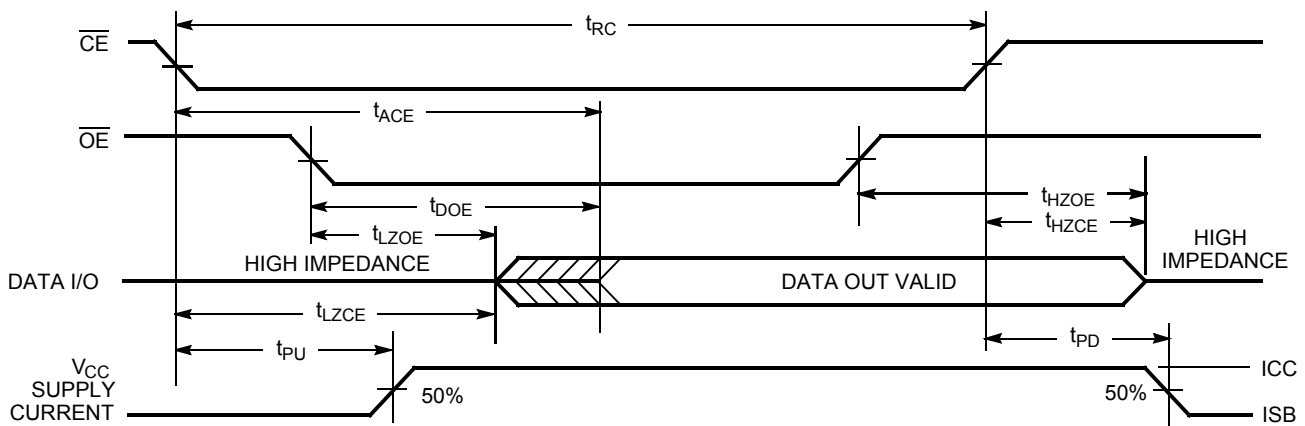

Figure 6. Read Cycle No. 2 [11, 12]



Notes

10. Device is continuously selected. \overline{OE} , $\overline{CE} = V_{IL}$.

11. \overline{WE} is HIGH for read cycle.

12. Address valid prior to or coincident with \overline{CE} transition LOW.

Switching Waveforms (continued)

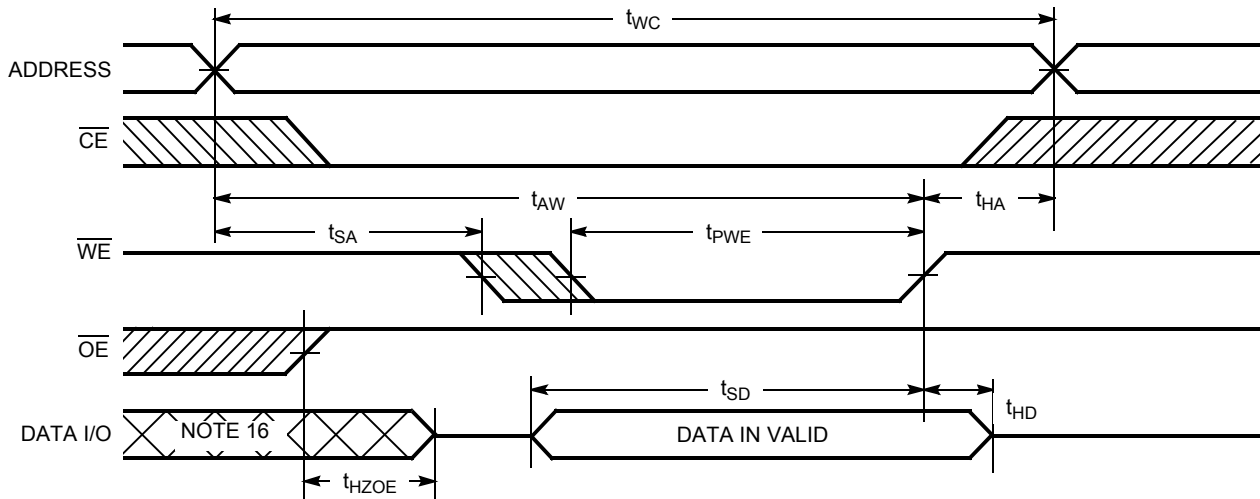
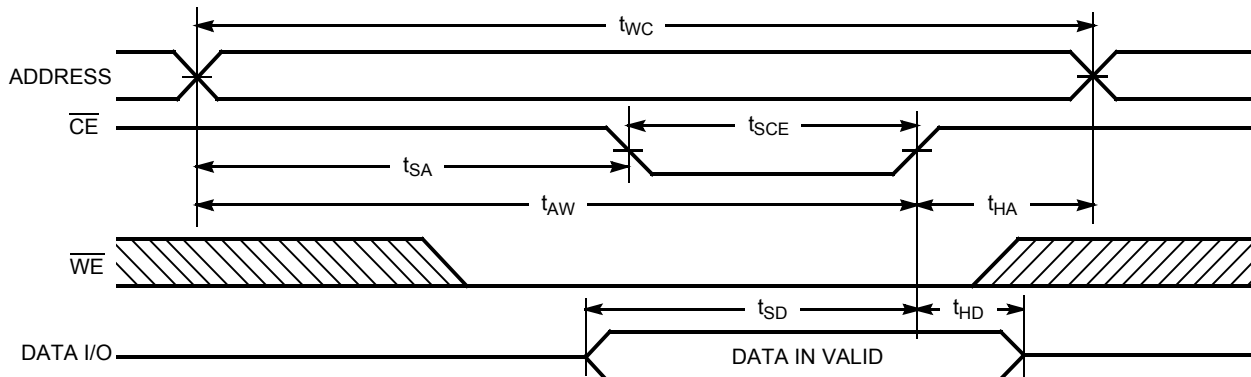
Figure 7. Write Cycle No. 1 ($\overline{\text{WE}}$ Controlled) [13, 14, 15]Figure 8. Write Cycle No. 2 ($\overline{\text{CE}}$ Controlled) [13, 14, 15]

Notes

13. The internal write time of the memory is defined by the overlap of $\overline{\text{CE}}$ LOW and $\overline{\text{WE}}$ LOW. Both signals must be LOW to initiate a write and either signal can terminate a write by going HIGH. The data input set-up and hold timing should be referenced to the rising edge of the signal that terminates the write.
14. Data I/O is high impedance if $\overline{\text{OE}} = V_{\text{IH}}$.
15. If $\overline{\text{CE}}$ goes HIGH simultaneously with $\overline{\text{WE}}$ HIGH, the output remains in a high-impedance state.
16. During this period, the I/Os are in the output state and input signals should not be applied.

Switching Waveforms (continued)

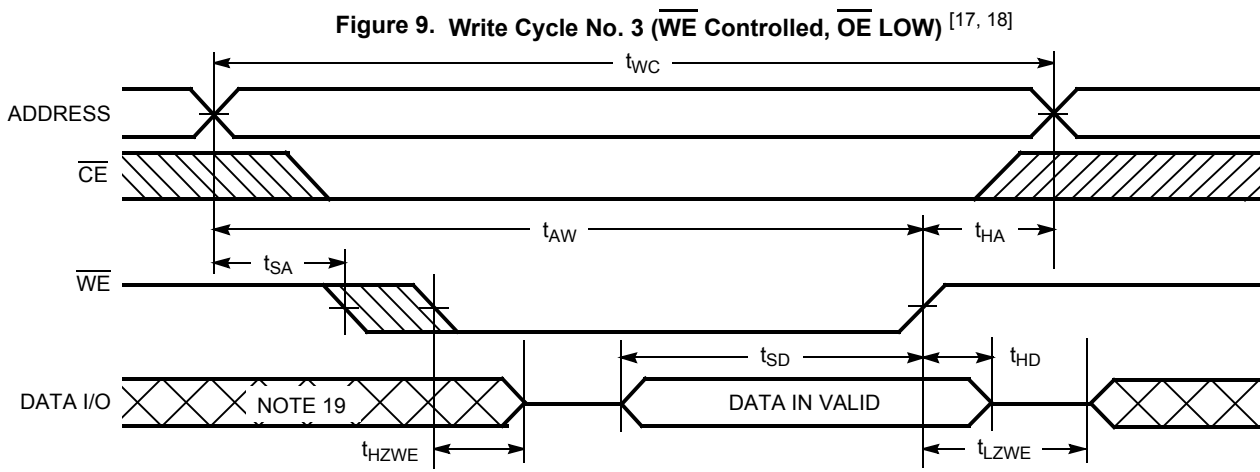
**Notes**

17. If \overline{CE} goes HIGH simultaneously with \overline{WE} HIGH, the output remains in a high-impedance state.
18. The minimum write cycle pulse width should be equal to the sum of t_{HZWE} and t_{SD} .
19. During this period, the I/Os are in the output state and input signals should not be applied.



Truth Table

$\overline{\text{CE}}$	$\overline{\text{WE}}$	$\overline{\text{OE}}$	Input/Output	Mode	Power
H	X	X	High Z	Deselect/Power-down	Standby (I_{SB})
L	H	L	Data Out	Read	Active (I_{CC})
L	L	X	Data In	Write	Active (I_{CC})
L	H	H	High Z	Deselect, Output disabled	Active (I_{CC})



Ordering Information

Cypress offers other versions of this type of product in many different configurations and features. The following table contains only the list of parts that are currently available.

For a complete listing of all options, visit the Cypress website at www.cypress.com and refer to the product summary page at <http://www.cypress.com/products> or contact your local sales representative.

Cypress maintains a worldwide network of offices, solution centers, manufacturer's representatives and distributors. To find the office closest to you, visit us at <http://www.cypress.com/go/datasheet/offices>.

Speed (ns)	Ordering Code	Package Diagram	Package Type	Operating Range
12	CY7C1399BN-12ZXC	51-85071	28-pin TSOP I (Pb-free)	Commercial
	CY7C1399BNL-12ZXC		28-pin TSOP I (Pb-free)	
	CY7C1399BN-12VXI	51-85031	28-pin molded SOJ (Pb-free)	Industrial

Contact your local sales representative regarding availability of these parts.

Ordering Code Definitions

CY 7 C 1 399 BN L - XX X X C

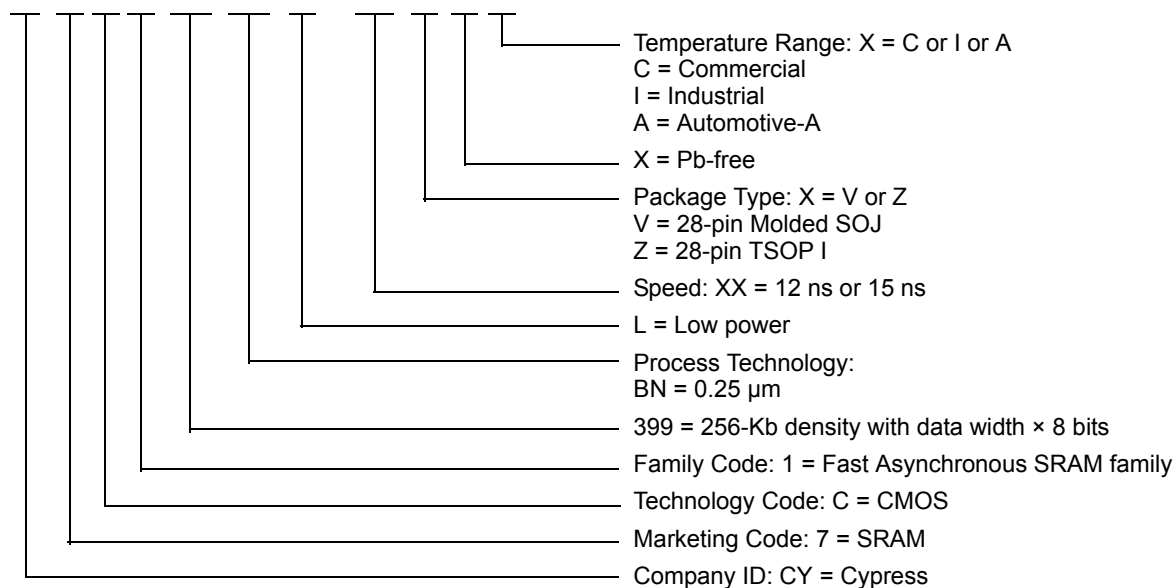

Package Diagrams**Figure 10. 28-pin SOJ (300 Mils) V28.3 (Molded SOJ V21) Package Outline, 51-85031****28 Lead (300 Mil) Molded SOJ V21**

NOTE :

1. JEDEC STD REF M0088
2. BODY LENGTH DIMENSION DOES NOT INCLUDE MOLD PROTRUSION/END FLASH
MOLD PROTRUSION/END FLASH SHALL NOT EXCEED 0.006 in (0.152 mm) PER SIDE
3. DIMENSIONS IN INCHES MIN.
MAX.

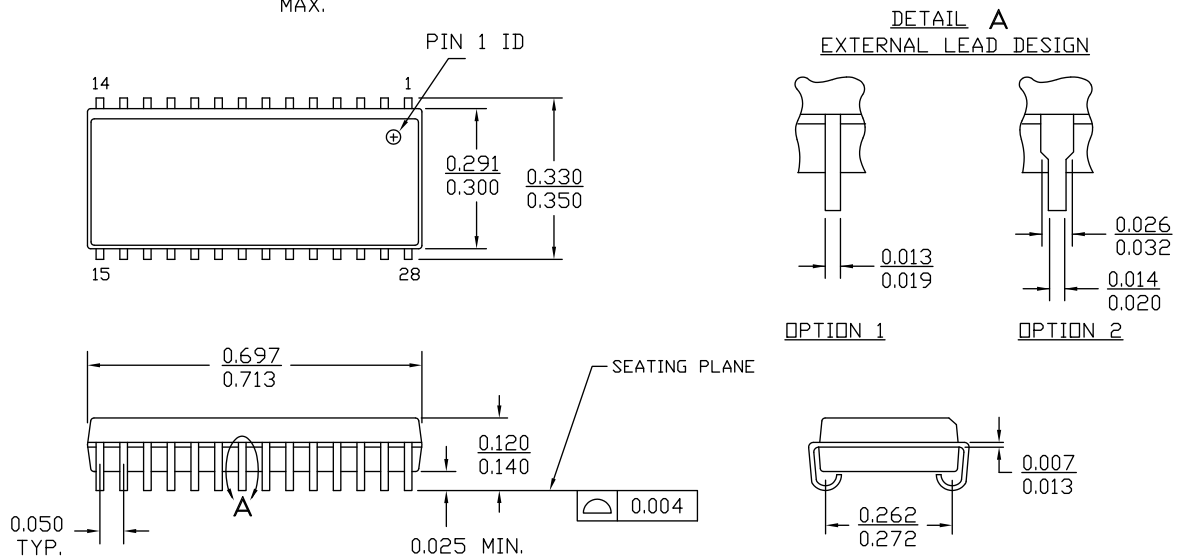

Package Diagrams (continued)**Figure 11. 28-pin TSOP I (8 × 13.4 × 1.2 mm) Z28 (Standard) Package Outline, 51-85071**

NOTE: ORIENTATION I.D. MAY BE LOCATED EITHER AS SHOWN IN OPTION 1 OR OPTION 2

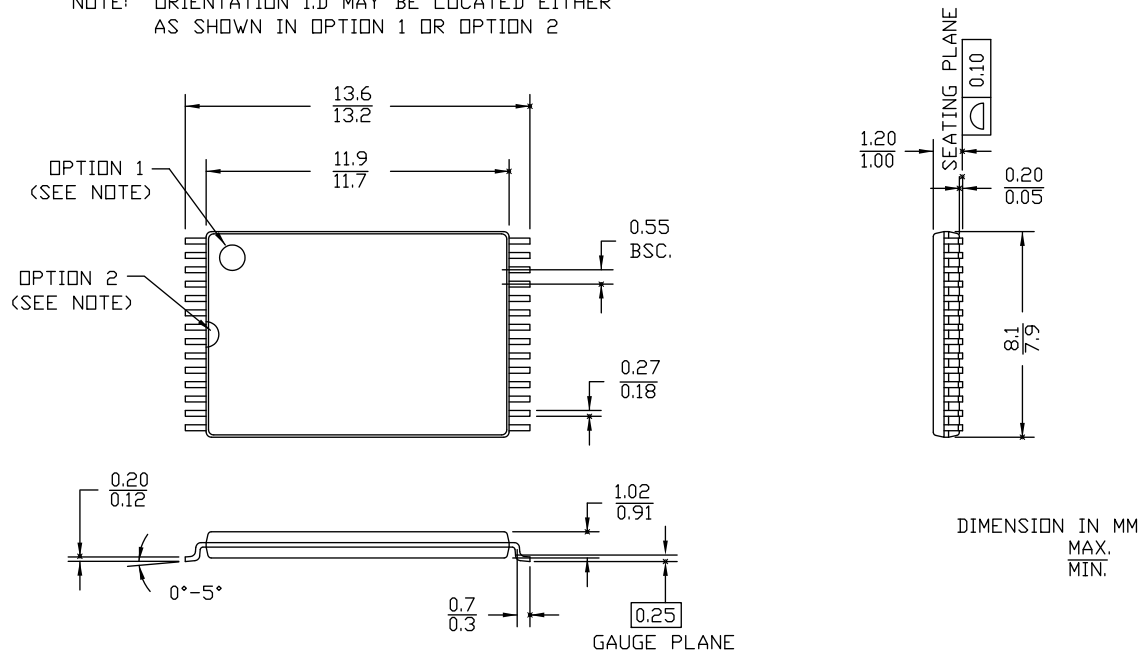

51-85071 *J



Acronyms

Acronym	Description
\overline{CE}	Chip Enable
CMOS	Complementary Metal Oxide Semiconductor
I/O	Input/Output
\overline{OE}	Output Enable
SRAM	Static Random Access Memory
TSOP	Thin Small Outline Package
\overline{WE}	Write Enable

Document Conventions

Units of Measure

Symbol	Unit of Measure
$^{\circ}\text{C}$	degree Celsius
MHz	megahertz
μA	microampere
mA	milliampere
mV	millivolt
mW	milliwatt
ns	nanosecond
pF	picofarad
V	volt
W	watt



Document History Page

Document Title: CY7C1399BN, 256-Kbit (32 K × 8) Static RAM Document Number: 001-06490				
Revision	ECN	Orig. of Change	Submission Date	Description of Change
**	423877	NXR	See ECN	New data sheet.
*A	498575	NXR	See ECN	Added Automotive-A range related information in all instances across the document. Updated Electrical Characteristics : Removed I _{OS} parameter and its details. Updated Ordering Information .
*B	2896382	AJU	03/19/2010	Updated Ordering Information : Removed obsolete part numbers. Updated Package Diagrams .
*C	3053362	PRAS	10/08/2010	Updated Ordering Information : Removed pruned part numbers CY7C1399BNL-15VXC and CY7C1399BNL-15VXCT. Added Ordering Code Definitions .
*D	3383869	TAVA	09/26/2011	Rearranged sections for better clarity. Updated Features : Added Commercial Temperature Range related information. Updated Functional Description : Removed Note "For guidelines on SRAM system design, please refer to the 'System Design Guidelines' Cypress application note, available on the internet at www.cypress.com website." and its reference. Updated Switching Waveforms : Modified the notes in figures under Read cycle and Write cycle sections. Updated Package Diagrams . Added Acronyms and Units of Measure . Updated to new template.
*E	4121360	VINI	09/12/2013	Updated to new template. Completing Sunset Review.
*F	4540416	VINI	10/16/2014	Updated Switching Waveforms : Updated Note 18. Updated Package Diagrams : spec 51-85071 – Changed revision from *I to *J. Completing Sunset Review.
*G	4578447	VINI	01/16/2015	Updated Functional Description : Added "For a complete list of related documentation, click here ." at the end. Updated Ordering Information : Removed the prune part numbers CY7C1399BN-12VXC and CY7C1399BN-15VXA. Updated Package Diagrams : spec 51-85031 – Changed revision from *E to *F. Updated to new template.
*H	4985705	NILE	10/24/2015	No technical updates. Completing Sunset Review.
*I	6013894	AESATMP9	01/04/2018	Updated logo and copyright.



Sales, Solutions, and Legal Information

Worldwide Sales and Design Support

Cypress maintains a worldwide network of offices, solution centers, manufacturer's representatives, and distributors. To find the office closest to you, visit us at [Cypress Locations](#).

Products

Arm [®] Cortex [®] Microcontrollers	cypress.com/arm
Automotive	cypress.com/automotive
Clocks & Buffers	cypress.com/clocks
Interface	cypress.com/interface
Internet of Things	cypress.com/iot
Memory	cypress.com/memory
Microcontrollers	cypress.com/mcu
PSoC	cypress.com/psoc
Power Management ICs	cypress.com/pmhc
Touch Sensing	cypress.com/touch
USB Controllers	cypress.com/usb
Wireless Connectivity	cypress.com/wireless

PSoC[®] Solutions

[PSoC 1](#) | [PSoC 3](#) | [PSoC 4](#) | [PSoC 5LP](#) | [PSoC 6 MCU](#)

Cypress Developer Community

[Community](#) | [Projects](#) | [Video](#) | [Blogs](#) | [Training](#) | [Components](#)

Technical Support

cypress.com/support

© Cypress Semiconductor Corporation, 2006-2018. This document is the property of Cypress Semiconductor Corporation and its subsidiaries, including Spansion LLC ("Cypress"). This document, including any software or firmware included or referenced in this document ("Software"), is owned by Cypress under the intellectual property laws and treaties of the United States and other countries worldwide. Cypress reserves all rights under such laws and treaties and does not, except as specifically stated in this paragraph, grant any license under its patents, copyrights, trademarks, or other intellectual property rights. If the Software is not accompanied by a license agreement and you do not otherwise have a written agreement with Cypress governing the use of the Software, then Cypress hereby grants you a personal, non-exclusive, nontransferable license (without the right to sublicense) (1) under its copyright rights in the Software (a) for Software provided in source code form, to modify and reproduce the Software solely for use with Cypress hardware products, only internally within your organization, and (b) to distribute the Software in binary code form externally to end users (either directly or indirectly through resellers and distributors), solely for use on Cypress hardware product units, and (2) under those claims of Cypress's patents that are infringed by the Software (as provided by Cypress, unmodified) to make, use, distribute, and import the Software solely for use with Cypress hardware products. Any other use, reproduction, modification, translation, or compilation of the Software is prohibited.

TO THE EXTENT PERMITTED BY APPLICABLE LAW, CYPRESS MAKES NO WARRANTY OF ANY KIND, EXPRESS OR IMPLIED, WITH REGARD TO THIS DOCUMENT OR ANY SOFTWARE OR ACCOMPANYING HARDWARE, INCLUDING, BUT NOT LIMITED TO, THE IMPLIED WARRANTIES OF MERCHANTABILITY AND FITNESS FOR A PARTICULAR PURPOSE. No computing device can be absolutely secure. Therefore, despite security measures implemented in Cypress hardware or software products, Cypress does not assume any liability arising out of any security breach, such as unauthorized access to or use of a Cypress product. In addition, the products described in these materials may contain design defects or errors known as errata which may cause the product to deviate from published specifications. To the extent permitted by applicable law, Cypress reserves the right to make changes to this document without further notice. Cypress does not assume any liability arising out of the application or use of any product or circuit described in this document. Any information provided in this document, including any sample design information or programming code, is provided only for reference purposes. It is the responsibility of the user of this document to properly design, program, and test the functionality and safety of any application made of this information and any resulting product. Cypress products are not designed, intended, or authorized for use as critical components in systems designed or intended for the operation of weapons, weapons systems, nuclear installations, life-support devices or systems, other medical devices or systems (including resuscitation equipment and surgical implants), pollution control or hazardous substances management, or other uses where the failure of the device or system could cause personal injury, death, or property damage ("Unintended Uses"). A critical component is any component of a device or system whose failure to perform can be reasonably expected to cause the failure of the device or system, or to affect its safety or effectiveness. Cypress is not liable, in whole or in part, and you shall and hereby do release Cypress from any claim, damage, or other liability arising from or related to all Unintended Uses of Cypress products. You shall indemnify and hold Cypress harmless from and against all claims, costs, damages, and other liabilities, including claims for personal injury or death, arising from or related to any Unintended Uses of Cypress products.

Cypress, the Cypress logo, Spansion, the Spansion logo, and combinations thereof, WICED, PSoC, CapSense, EZ-USB, F-RAM, and Traveo are trademarks or registered trademarks of Cypress in the United States and other countries. For a more complete list of Cypress trademarks, visit cypress.com. Other names and brands may be claimed as property of their respective owners.

OUR CERTIFICATE

DiGi provide top-quality products and perfect service for customer worldwide through standardization, technological innovation and continuous improvement. DiGi through third-party certification, we stricly control the quality of products and services. Welcome your RFQ to

Email: Info@DiGi-Electronics.com



Tel: +00 852-30501935

RFQ Email: Info@DiGi-Electronics.com

DiGi is a global authorized distributor of electronic components.