

# CY7C1460KV33-167AXC Datasheet

[www.digi-electronics.com](http://www.digi-electronics.com)

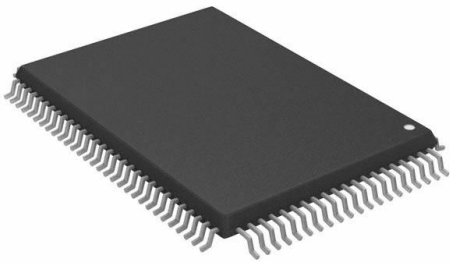

<https://www.DiGi-Electronics.com>

|                              |   |
|------------------------------|---|
| DiGi Electronics Part Number | CY7C1460KV33-167AXC-DG  |
| Manufacturer                 | <a href="#">Infineon Technologies</a>   |
| Manufacturer Product Number  | CY7C1460KV33-167AXC   |
| Description                  | IC SRAM 36MBIT PAR 100TQFP  |
| Detailed Description         | SRAM - Synchronous, SDR Memory IC 36Mbit Parallel 167 MHz 3.4 ns 100-TQFP (14x20) |

This model CY7C1460KV33-167AXC is available at DiGi Electronics.

DiGi Electronics offers a global database of semiconductor and electronic component datasheets.

We welcome your inquiries regarding pricing, lead time, or other product-related questions.

 [Request a Quote](#)

 [Datasheet Search](#)



Tel: +00 852-30501935

RFQ Email: [Info@DiGi-Electronics.com](mailto:Info@DiGi-Electronics.com)

DiGi is a global authorized distributor of electronic components.

## Purchase and inquiry

Manufacturer Product Number:

CY7C1460KV33-167AXC

Series:

NoBL™

DiGi-Electronics Programmable:

Not Verified

Memory Format:

SRAM

Memory Size:

36Mbit

Memory Interface:

Parallel

Write Cycle Time - Word, Page:

-

Voltage - Supply:

3.135V ~ 3.6V

Mounting Type:

Surface Mount

Supplier Device Package:

100-TQFP (14x20)

Manufacturer:

Infineon Technologies

Product Status:

Active

Memory Type:

Volatile

Technology:

SRAM - Synchronous, SDR

Memory Organization:

1M x 36

Clock Frequency:

167 MHz

Access Time:

3.4 ns

Operating Temperature:

0°C ~ 70°C (TA)

Package / Case:

100-LQFP

Base Product Number:

CY7C1460

## Environmental & Export classification

RoHS Status:

ROHS3 Compliant

REACH Status:

REACH Unaffected

HTSUS:

8542.32.0041

Moisture Sensitivity Level (MSL):

3 (168 Hours)

ECCN:

3A991B2A



**CY7C1460KV33**  
**CY7C1460KVE33**  
**CY7C1462KVE33**

## 36-Mbit (1M × 36/2M × 18) Pipelined SRAM with NoBL™ Architecture (With ECC)

### Features

- Pin-compatible and functionally equivalent to Zero Bus Turnaround (ZBT™)
- Supports 250-MHz bus operations with zero wait states
  - Available speed grades are 250, 200, and 167 MHz
- Internally self-timed output buffer control to eliminate the need to use asynchronous  $\overline{OE}$
- Fully-registered (inputs and outputs) for pipelined operation
- Byte write capability
- 3.3-V power supply
- 3.3-V/2.5-V I/O power supply
- Fast clock-to-output time
  - 2.5 ns (for 250-MHz device)
- Clock enable ( $\overline{CEN}$ ) pin to suspend operation
- Synchronous self-timed writes
- CY7C1460KV33, CY7C1460KVE33, CY7C1462KVE33 available in JEDEC-standard Pb-free 100-pin TQFP, Pb-free and non Pb-free 165-ball FBGA packages
- IEEE 1149.1 JTAG-compatible boundary scan
- Burst capability—linear or interleaved burst order
- “ZZ” sleep mode option
- On-chip Error Correction Code (ECC) to reduce Soft Error Rate (SER)

### Functional Description

The CY7C1460KV33/CY7C1460KVE33/CY7C1462KVE33 are 3.3 V, 1M × 36, and 2M × 18 synchronous pipelined burst SRAMs with No Bus Latency™ (NoBL™) logic, respectively. They are designed to support unlimited true back-to-back read/write operations with no wait states. The CY7C1460KV33/CY7C1460KVE33/CY7C1462KVE33 devices are equipped with the advanced (NoBL) logic required to enable consecutive read/write operations with data being transferred on every clock cycle.

This feature dramatically improves the throughput of data in systems that require frequent write and read transitions. The CY7C1460KV33/CY7C1460KVE33/CY7C1462KVE33 devices are pin-compatible and functionally equivalent to ZBT devices.

All synchronous inputs pass through input registers controlled by the rising edge of the clock. All data outputs pass through output registers controlled by the rising edge of the clock. The clock input is qualified by the clock enable ( $\overline{CEN}$ ) signal, which when deasserted suspends operation and extends the previous clock cycle.

Write operations are controlled by the byte write selects ( $\overline{BW}_a$ – $\overline{BW}_d$  for CY7C1460KV33/CY7C1460KVE33 and  $\overline{BW}_a$ – $\overline{BW}_b$  for CY7C1462KVE33) and a write enable ( $\overline{WE}$ ) input. All writes are conducted with on-chip synchronous self-timed write circuitry.

Three synchronous chip enables ( $\overline{CE}_1$ ,  $\overline{CE}_2$ , and  $\overline{CE}_3$ ) and an asynchronous output enable ( $\overline{OE}$ ) enable easy bank selection and output tristate control. To avoid bus contention, the output drivers are synchronously tristated during the data portion of a write sequence.

### Selection Guide

| Description               |      | 250 MHz | 200 MHz | 167 MHz | Unit |
|---------------------------|------|---------|---------|---------|------|
| Maximum access time       |      | 2.5     | 3.2     | 3.4     | ns   |
| Maximum operating current | × 18 | 220     | 190     | 170     | mA   |
|                           | × 36 | 240     | 210     | 190     |      |



**Logic Block Diagram – CY7C1460KV33**

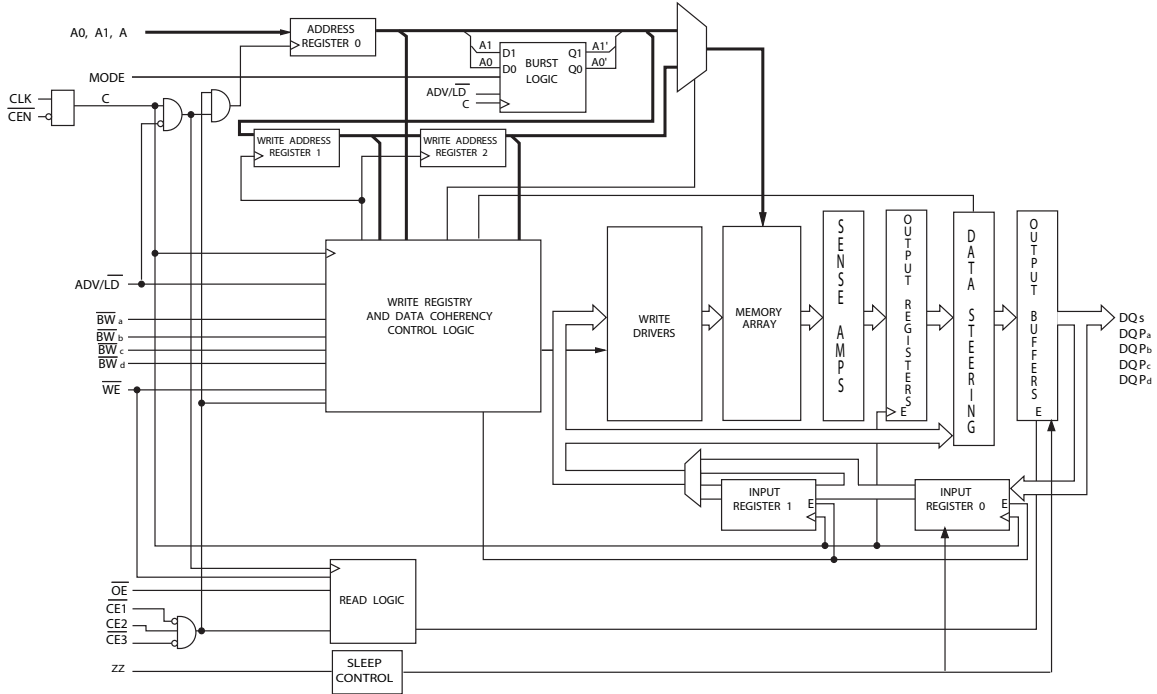

**Logic Block Diagram – CY7C1460KVE33**

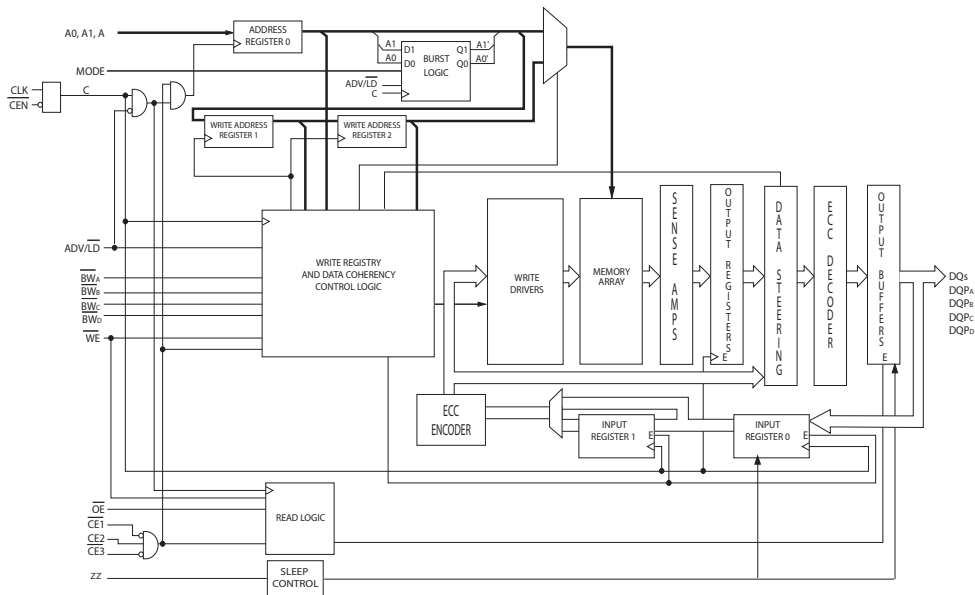



**Logic Block Diagram – CY7C1462KVE33**

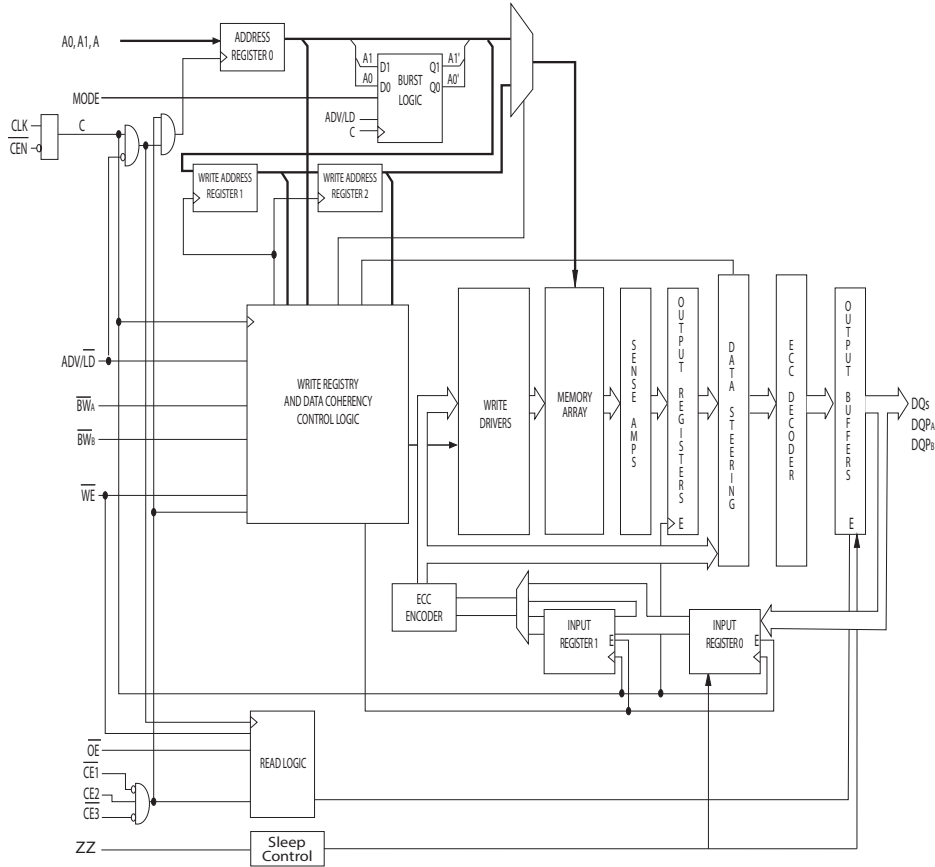



## Contents

|  |           |  |           |
|--|-----------|--|-----------|
| <b>Pin Configurations</b> .....                      | <b>5</b>  | <b>TAP DC Electrical Characteristics</b>             |           |
| <b>Pin Definitions</b> .....                         | <b>7</b>  | <b>and Operating Conditions</b> .....                | <b>17</b> |
| <b>Functional Overview</b> .....                     | <b>8</b>  | <b>Identification Register Definitions</b> .....     | <b>18</b> |
| Single Read Accesses .....                           | 8         | <b>Scan Register Sizes</b> .....                     | <b>18</b> |
| Burst Read Accesses .....                            | 8         | <b>Identification Codes</b> .....                    | <b>18</b> |
| Single Write Accesses .....                          | 9         | <b>Boundary Scan Order</b> .....                     | <b>19</b> |
| Burst Write Accesses .....                           | 9         | <b>Maximum Ratings</b> .....                         | <b>20</b> |
| Sleep Mode .....                                     | 9         | <b>Operating Range</b> .....                         | <b>20</b> |
| On-Chip ECC .....                                    | 9         | <b>Neutron Soft Error Immunity</b> .....             | <b>20</b> |
| Interleaved Burst Address Table .....                | 10        | <b>Electrical Characteristics</b> .....              | <b>20</b> |
| Linear Burst Address Table .....                     | 10        | <b>Capacitance</b> .....                             | <b>22</b> |
| ZZ Mode Electrical Characteristics .....             | 10        | <b>Thermal Resistance</b> .....                      | <b>22</b> |
| <b>Truth Table</b> .....                             | <b>11</b> | <b>AC Test Loads and Waveforms</b> .....             | <b>22</b> |
| <b>Partial Write Cycle Description</b> .....         | <b>12</b> | <b>Switching Characteristics</b> .....               | <b>23</b> |
| <b>Partial Write Cycle Description</b> .....         | <b>12</b> | <b>Switching Waveforms</b> .....                     | <b>24</b> |
| <b>IEEE 1149.1 Serial Boundary Scan (JTAG)</b> ..... | <b>13</b> | <b>Ordering Information</b> .....                    | <b>26</b> |
| Disabling the JTAG Feature .....                     | 13        | Ordering Code Definitions .....                      | 26        |
| Test Access Port (TAP) .....                         | 13        | <b>Package Diagrams</b> .....                        | <b>27</b> |
| PERFORMING A TAP RESET .....                         | 13        | <b>Acronyms</b> .....                                | <b>29</b> |
| TAP REGISTERS .....                                  | 13        | <b>Document Conventions</b> .....                    | <b>29</b> |
| TAP Instruction Set .....                            | 14        | Units of Measure .....                               | 29        |
| <b>TAP Controller State Diagram</b> .....            | <b>15</b> | <b>Document History Page</b> .....                   | <b>30</b> |
| <b>TAP Controller Block Diagram</b> .....            | <b>15</b> | <b>Sales, Solutions, and Legal Information</b> ..... | <b>31</b> |
| <b>TAP Timing Diagram</b> .....                      | <b>15</b> | Worldwide Sales and Design Support .....             | 31        |
| <b>TAP AC Switching Characteristics</b> .....        | <b>16</b> | Products .....                                       | 31        |
| <b>3.3 V TAP AC Test Conditions</b> .....            | <b>17</b> | PSoC® Solutions .....                                | 31        |
| <b>3.3 V TAP AC Output Load Equivalent</b> .....     | <b>17</b> | Cypress Developer Community .....                    | 31        |
| <b>2.5 V TAP AC Test Conditions</b> .....            | <b>17</b> | Technical Support .....                              | 31        |
| <b>2.5 V TAP AC Output Load Equivalent</b> .....     | <b>17</b> |  |           |





## Pin Configurations *(continued)*

**Figure 2. 165-ball FBGA Pinout**

**CY7C1460KVE33 (1M × 36)**

|          | <b>1</b>         | <b>2</b>        | <b>3</b>          | <b>4</b>          | <b>5</b>          | <b>6</b>          | <b>7</b>         | <b>8</b>        | <b>9</b>         | <b>10</b>       | <b>11</b>        |
|----------|------------------|-----------------|-------------------|-------------------|-------------------|-------------------|------------------|-----------------|------------------|-----------------|------------------|
| <b>A</b> | NC/576M          | A               | $\overline{CE}_1$ | $\overline{BW}_c$ | $\overline{BW}_b$ | $\overline{CE}_3$ | $\overline{CEN}$ | ADV/LD          | A                | A               | NC               |
| <b>B</b> | NC/1G            | A               | CE2               | $\overline{BW}_d$ | $\overline{BW}_a$ | CLK               | $\overline{WE}$  | $\overline{OE}$ | A                | A               | NC               |
| <b>C</b> | DQP <sub>c</sub> | NC              | V <sub>DDQ</sub>  | V <sub>SS</sub>   | V <sub>SS</sub>   | V <sub>SS</sub>   | V <sub>SS</sub>  | V <sub>SS</sub> | V <sub>DDQ</sub> | NC              | DQP <sub>b</sub> |
| <b>D</b> | DQ <sub>c</sub>  | DQ <sub>c</sub> | V <sub>DDQ</sub>  | V <sub>DD</sub>   | V <sub>SS</sub>   | V <sub>SS</sub>   | V <sub>SS</sub>  | V <sub>DD</sub> | V <sub>DDQ</sub> | DQ <sub>b</sub> | DQ <sub>b</sub>  |
| <b>E</b> | DQ <sub>c</sub>  | DQ <sub>c</sub> | V <sub>DDQ</sub>  | V <sub>DD</sub>   | V <sub>SS</sub>   | V <sub>SS</sub>   | V <sub>SS</sub>  | V <sub>DD</sub> | V <sub>DDQ</sub> | DQ <sub>b</sub> | DQ <sub>b</sub>  |
| <b>F</b> | DQ <sub>c</sub>  | DQ <sub>c</sub> | V <sub>DDQ</sub>  | V <sub>DD</sub>   | V <sub>SS</sub>   | V <sub>SS</sub>   | V <sub>SS</sub>  | V <sub>DD</sub> | V <sub>DDQ</sub> | DQ <sub>b</sub> | DQ <sub>b</sub>  |
| <b>G</b> | DQ <sub>c</sub>  | DQ <sub>c</sub> | V <sub>DDQ</sub>  | V <sub>DD</sub>   | V <sub>SS</sub>   | V <sub>SS</sub>   | V <sub>SS</sub>  | V <sub>DD</sub> | V <sub>DDQ</sub> | DQ <sub>b</sub> | DQ <sub>b</sub>  |
| <b>H</b> | NC               | NC              | NC                | V <sub>DD</sub>   | V <sub>SS</sub>   | V <sub>SS</sub>   | V <sub>SS</sub>  | V <sub>DD</sub> | NC               | NC              | ZZ               |
| <b>J</b> | DQ <sub>d</sub>  | DQ <sub>d</sub> | V <sub>DDQ</sub>  | V <sub>DD</sub>   | V <sub>SS</sub>   | V <sub>SS</sub>   | V <sub>SS</sub>  | V <sub>DD</sub> | V <sub>DDQ</sub> | DQ <sub>a</sub> | DQ <sub>a</sub>  |
| <b>K</b> | DQ <sub>d</sub>  | DQ <sub>d</sub> | V <sub>DDQ</sub>  | V <sub>DD</sub>   | V <sub>SS</sub>   | V <sub>SS</sub>   | V <sub>SS</sub>  | V <sub>DD</sub> | V <sub>DDQ</sub> | DQ <sub>a</sub> | DQ <sub>a</sub>  |
| <b>L</b> | DQ <sub>d</sub>  | DQ <sub>d</sub> | V <sub>DDQ</sub>  | V <sub>DD</sub>   | V <sub>SS</sub>   | V <sub>SS</sub>   | V <sub>SS</sub>  | V <sub>DD</sub> | V <sub>DDQ</sub> | DQ <sub>a</sub> | DQ <sub>a</sub>  |
| <b>M</b> | DQ <sub>d</sub>  | DQ <sub>d</sub> | V <sub>DDQ</sub>  | V <sub>DD</sub>   | V <sub>SS</sub>   | V <sub>SS</sub>   | V <sub>SS</sub>  | V <sub>DD</sub> | V <sub>DDQ</sub> | DQ <sub>a</sub> | DQ <sub>a</sub>  |
| <b>N</b> | DQP <sub>d</sub> | NC              | V <sub>DDQ</sub>  | V <sub>SS</sub>   | NC                | NC                | NC               | V <sub>SS</sub> | V <sub>DDQ</sub> | NC              | DQP <sub>a</sub> |
| <b>P</b> | NC/144M          | NC/72M          | A                 | A                 | TDI               | A1                | TDO              | A               | A                | A               | NC/288M          |
| <b>R</b> | MODE             | A               | A                 | A                 | TMS               | A0                | TCK              | A               | A                | A               | A                |



## Pin Definitions

| Pin Name   | I/O Type                       | Pin Description  |
|--|--------------------------------|--|
| A <sub>0</sub> , A <sub>1</sub> , A  | Input-synchronous              | <b>Address inputs used to select one of the address locations.</b> Sampled at the rising edge of the CLK.  |
| $\overline{BW}_a$ , $\overline{BW}_b$ ,<br>$\overline{BW}_c$ , $\overline{BW}_d$ | Input-synchronous              | <b>Byte write select inputs, active LOW.</b> Qualified with $\overline{WE}$ to conduct writes to the SRAM. Sampled on the rising edge of CLK. $\overline{BW}_a$ controls DQ <sub>a</sub> and DQP <sub>a</sub> , $\overline{BW}_b$ controls DQ <sub>b</sub> and DQP <sub>b</sub> , $\overline{BW}_c$ controls DQ <sub>c</sub> and DQP <sub>c</sub> , $\overline{BW}_d$ controls DQ <sub>d</sub> and DQP <sub>d</sub> .  |
| $\overline{WE}$  | Input-synchronous              | <b>Write enable input, active LOW.</b> Sampled on the rising edge of CLK if $\overline{CEN}$ is active LOW. This signal must be asserted LOW to initiate a write sequence.   |
| ADV/LD   | Input-synchronous              | <b>Advance/load input used to advance the on-chip address counter or load a new address.</b> When HIGH (and $\overline{CEN}$ is asserted LOW) the internal burst counter is advanced. When LOW, a new address can be loaded into the device for an access. After being deselected, ADV/LD should be driven LOW to load a new address.  |
| CLK  | Input-clock                    | <b>Clock input.</b> Used to capture all synchronous inputs to the device. CLK is qualified with $\overline{CEN}$ . CLK is only recognized if $\overline{CEN}$ is active LOW.   |
| $\overline{CE}_1$  | Input-synchronous              | <b>Chip enable 1 input, active LOW.</b> Sampled on the rising edge of CLK. Used in conjunction with $\overline{CE}_2$ and $\overline{CE}_3$ to select/deselect the device.   |
| $\overline{CE}_2$  | Input-synchronous              | <b>Chip enable 2 input, active HIGH.</b> Sampled on the rising edge of CLK. Used in conjunction with $\overline{CE}_1$ and $\overline{CE}_3$ to select/deselect the device.  |
| $\overline{CE}_3$  | Input-synchronous              | <b>Chip enable 3 input, active LOW.</b> Sampled on the rising edge of CLK. Used in conjunction with $\overline{CE}_1$ and $\overline{CE}_2$ to select/deselect the device.   |
| $\overline{OE}$  | Input-asynchronous             | <b>Output enable, active LOW.</b> Combined with the synchronous logic block inside the device to control the direction of the I/O pins. When LOW, the I/O pins are allowed to behave as outputs. When deasserted HIGH, I/O pins are tristated, and act as input data pins. $\overline{OE}$ is masked during the data portion of a write sequence, during the first clock when emerging from a deselected state and when the device has been deselected.  |
| $\overline{CEN}$   | Input-synchronous              | <b>Clock enable input, active LOW.</b> When asserted LOW the clock signal is recognized by the SRAM. When deasserted HIGH the clock signal is masked. Since deasserting $\overline{CEN}$ does not deselect the device, $\overline{CEN}$ can be used to extend the previous cycle when required.  |
| DQ <sub>a</sub> , DQ <sub>b</sub> , DQ <sub>c</sub> ,<br>DQ <sub>d</sub>         | I/O-synchronous                | <b>Bidirectional data I/O lines.</b> As inputs, they feed into an on-chip data register that is triggered by the rising edge of CLK. As outputs, they deliver the data contained in the memory location specified by A <sub>X</sub> during the read cycle. The direction of the pins is controlled by $\overline{OE}$ and the internal control logic. When $\overline{OE}$ is asserted LOW, the pins can behave as outputs. When HIGH, DQ <sub>a</sub> –DQ <sub>d</sub> are placed in a tristate condition. The outputs are automatically tristated during the data portion of a write sequence, during the first clock when emerging from a deselected state, and when the device is deselected, regardless of the state of $\overline{OE}$ . |
| DQP <sub>a</sub> , DQP <sub>b</sub> ,<br>DQP <sub>c</sub> , DQP <sub>d</sub>     | I/O-synchronous                | <b>Bidirectional data parity I/O lines.</b> Functionally, these signals are identical to DQ <sub>[31:0]</sub> . During write sequences, DQP <sub>a</sub> is controlled by $\overline{BW}_a$ , DQP <sub>b</sub> is controlled by $\overline{BW}_b$ , DQP <sub>c</sub> is controlled by $\overline{BW}_c$ , and DQP <sub>d</sub> is controlled by $\overline{BW}_d$ .  |
| MODE   | Input strap pin                | <b>Mode input.</b> Selects the burst order of the device. Tied HIGH selects the interleaved burst order. Pulled LOW selects the linear burst order. MODE should not change states during operation. When left floating MODE defaults HIGH, to an interleaved burst order.  |
| TDO  | JTAG serial output synchronous | <b>Serial data-out to the JTAG circuit.</b> Delivers data on the negative edge of TCK.   |
| TDI  | JTAG serial input synchronous  | <b>Serial data-in to the JTAG circuit.</b> Sampled on the rising edge of TCK.  |
| TMS  | Test mode select synchronous   | <b>This pin controls the test access port state machine.</b> Sampled on the rising edge of TCK.  |
| TCK  | JTAG-clock                     | <b>Clock input to the JTAG circuitry.</b>  |



## Pin Definitions *(continued)*

| Pin Name         | I/O Type           | Pin Description   |
|------------------|--------------------|---|
| V <sub>DD</sub>  | Power supply       | <b>Power supply inputs to the core of the device.</b>   |
| V <sub>DDQ</sub> | I/O power supply   | <b>Power supply for the I/O circuitry.</b>  |
| V <sub>SS</sub>  | Ground             | <b>Ground for the device.</b> Should be connected to ground of the system.  |
| NC               | N/A                | <b>No connects.</b> This pin is not connected to the die.   |
| NC/72M           | N/A                | <b>Not connected to the die.</b> Can be tied to any voltage level.  |
| NC/144M          | N/A                | <b>Not connected to the die.</b> Can be tied to any voltage level.  |
| NC/288M          | N/A                | <b>Not connected to the die.</b> Can be tied to any voltage level.  |
| NC/576M          | N/A                | <b>Not connected to the die.</b> Can be tied to any voltage level.  |
| NC/1G            | N/A                | <b>Not connected to the die.</b> Can be tied to any voltage level.  |
| ZZ               | Input-asynchronous | <b>ZZ “sleep” input.</b> This active HIGH input places the device in a non-time critical “sleep” condition with data integrity preserved. During normal operation, this pin can be connected to V <sub>SS</sub> or left floating. ZZ pin has an internal pull-down. |

## Functional Overview

The CY7C1460KV33/CY7C1460KVE33/CY7C1462KVE33 devices are synchronous-pipelined burst NoBL SRAMs designed specifically to eliminate wait states during write/read transitions. All synchronous inputs pass through input registers controlled by the rising edge of the clock. The clock signal is qualified with the clock enable input signal (CEN). If CEN is HIGH, the clock signal is not recognized and all internal states are maintained. All synchronous operations are qualified with CEN. All data outputs pass through output registers controlled by the rising edge of the clock. Maximum access delay from the clock rise (t<sub>CO</sub>) is 2.5 ns (250-MHz device).

Accesses can be initiated by asserting all three chip enables (CE<sub>1</sub>, CE<sub>2</sub>, and CE<sub>3</sub>) active at the rising edge of the clock. If clock enable (CEN) is active LOW and ADV/LD is asserted LOW, the address presented to the device is latched. The access can either be a read or write operation, depending on the status of the write enable (WE). BW<sub>[x]</sub> can be used to conduct byte write operations.

Write operations are qualified by the write enable (WE). All writes are simplified with on-chip synchronous self timed write circuitry.

Three synchronous chip enables (CE<sub>1</sub>, CE<sub>2</sub>, and CE<sub>3</sub>) and an asynchronous output enable (OE) simplify depth expansion. All operations (reads, writes, and deselections) are pipelined. ADV/LD should be driven LOW after the device has been deselected to load a new address for the next operation.

### Single Read Accesses

A read access is initiated when the following conditions are satisfied at clock rise:

- CEN is asserted LOW
- CE<sub>1</sub>, CE<sub>2</sub>, and CE<sub>3</sub> are all asserted active

- The write enable input signal WE is deasserted HIGH
- ADV/LD is asserted LOW

The address presented to the address inputs is latched into the address register and presented to the memory core and control logic. The control logic determines that a read access is in progress and allows the requested data to propagate to the input of the output register. At the rising edge of the next clock, the requested data is allowed to propagate through the output register and on to the data bus within 2.5 ns (250-MHz device) provided OE is active LOW. After the first clock of the read access, the output buffers are controlled by OE and the internal control logic. OE must be driven LOW for the device to drive out the requested data. During the second clock, a subsequent operation (read/write/deselect) can be initiated. Deselecting the device is also pipelined. Therefore, when the SRAM is deselected at clock rise by one of the chip enable signals, its output tristates following the next clock rise.

### Burst Read Accesses

The CY7C1460KV33/CY7C1460KVE33/CY7C1462KVE33 have an on-chip burst counter that enables the user the ability to supply a single address and conduct up to four reads without reasserting the address inputs. ADV/LD must be driven LOW to load a new address into the SRAM, as described in the [Single Read Accesses](#) section earlier. The sequence of the burst counter is determined by the MODE input signal. A LOW input on MODE selects a linear burst mode, a HIGH selects an interleaved burst sequence. Both burst counters use A0 and A1 in the burst sequence, and wrap around when incremented sufficiently. A HIGH input on ADV/LD increments the internal burst counter regardless of the state of chip enable inputs or WE. WE is latched at the beginning of a burst cycle. Therefore, the type of access (read or write) is maintained throughout the burst sequence.



### Single Write Accesses

Write accesses are initiated when the following conditions are satisfied at clock rise:

- $\overline{CEN}$  is asserted LOW
- $\overline{CE}_1$ ,  $CE_2$ , and  $\overline{CE}_3$  are all asserted active
- The write signal  $\overline{WE}$  is asserted LOW

The address presented to the address inputs is loaded into the address register. The write signals are latched into the control logic block.

On the subsequent clock rise, the data lines are automatically tristated regardless of the state of the  $\overline{OE}$  input signal. This enables the external logic to present the data on DQ and DQP ( $DQ_{a,b,c,d}/DQP_{a,b,c,d}$  for CY7C1460KV33/CY7C1460KVE33 and  $DQ_{a,b}/DQP_{a,b}$  for CY7C1462KVE33). In addition, the address for the subsequent access (read/write/deselect) is latched into the address register (provided the appropriate control signals are asserted).

On the next clock rise, the data presented to DQ and DQP ( $DQ_{a,b,c,d}/DQP_{a,b,c,d}$  for CY7C1460KV33/CY7C1460KVE33 and  $DQ_{a,b}/DQP_{a,b}$  for CY7C1462KVE33), or a subset for byte write operations, see the Write Cycle Description table for details) inputs is latched into the device and the write is complete.

The data written during the write operation is controlled by the  $\overline{BW}$  ( $\overline{BW}_{a,b,c,d}$  for CY7C1460KV33/CY7C1460KVE33 and  $\overline{BW}_{a,b}$  for CY7C1462KVE33) signals. The CY7C1460KV33/CY7C1460KVE33/CY7C1462KVE33 provides byte-write capability that is described in the Write Cycle Description table. Asserting the write enable input ( $\overline{WE}$ ) with the selected byte write select ( $\overline{BW}$ ) input selectively writes to only the desired bytes. Bytes not selected during a byte write operation remains unaltered. A synchronous self timed write mechanism has been provided to simplify the write operations. Byte write capability has been included to simplify read/modify/write sequences, which can be reduced to simple byte write operations.

Because the CY7C1460KV33/ CY7C1460KVE33/ CY7C1462KVE33 devices are common I/O devices, data should not be driven into the device while the outputs are active. The output enable ( $\overline{OE}$ ) can be deasserted HIGH before presenting data to the DQ and DQP ( $DQ_{a,b,c,d}/DQP_{a,b,c,d}$  for CY7C1460KV33/CY7C1460KVE33 and  $DQ_{a,b}/DQP_{a,b}$  for CY7C1462KVE33) inputs. Doing so tristates the output drivers. As a safety precaution, DQ and DQP ( $DQ_{a,b,c,d}/DQP_{a,b,c,d}$  for

CY7C1460KV33/CY7C1460KVE33 and  $DQ_{a,b}/DQP_{a,b}$  for CY7C1462KVE33) are automatically tristated during the data portion of a write cycle, regardless of the state of  $\overline{OE}$ .

### Burst Write Accesses

The CY7C1460KV33/CY7C1460KVE33/CY7C1462KVE33 devices have an on-chip burst counter that allows the user the ability to supply a single address and conduct up to four WRITE operations without reasserting the address inputs.  $\overline{ADV}/\overline{LD}$  must be driven LOW to load the initial address, as described in the Single Write Accesses section. When  $\overline{ADV}/\overline{LD}$  is driven HIGH on the subsequent clock rise, the chip enables ( $\overline{CE}_1$ ,  $CE_2$ , and  $\overline{CE}_3$ ) and  $\overline{WE}$  inputs are ignored and the burst counter is incremented. The correct  $\overline{BW}$  inputs ( $\overline{BW}_{a,b,c,d}$  for CY7C1460KV33/CY7C1460KVE33 and  $\overline{BW}_{a,b}$  for CY7C1462KVE33) must be driven in each cycle of the burst write to write the correct bytes of data.

### Sleep Mode

The ZZ input pin is an asynchronous input. Asserting ZZ places the SRAM in a power conservation “sleep” mode. Two clock cycles are required to enter into or exit from this “sleep” mode. While in this mode, data integrity is guaranteed. Accesses pending when entering the “sleep” mode are not considered valid nor is the completion of the operation guaranteed. The device must be deselected prior to entering the “sleep” mode.  $\overline{CE}_1$ ,  $CE_2$ , and  $\overline{CE}_3$ , must remain inactive for the duration of  $t_{ZZREC}$  after the ZZ input returns LOW.

### On-Chip ECC

CY7C1460KVE33/CY7C1462KVE33 SRAMs include an on-chip ECC algorithm that detects and corrects all single-bit memory errors, including Soft Error Upset (SEU) events induced by cosmic rays, alpha particles, and so on. The resulting Soft Error Rate (SER) of these devices is anticipated to be <0.01 FITs/Mb, a 4-order-of-magnitude improvement over comparable SRAMs with no on-chip ECC, which typically have an SER of 200 FITs/Mb or more. To protect the internal data, ECC parity bits (invisible to the user) are used.

The ECC algorithm does not correct multi-bit errors. However, Cypress SRAMs are designed in such a way that a single SER event has a very low probability of causing a multi-bit error across any data word. The extreme rarity of multi-bit errors results in a SER of <0.01 FITs/Mb.



### Interleaved Burst Address Table

(MODE = Floating or  $V_{DD}$ )

| First Address<br>A1, A0 | Second Address<br>A1, A0 | Third Address<br>A1, A0 | Fourth Address<br>A1, A0 |
|-------------------------|--------------------------|-------------------------|--------------------------|
| 00                      | 01                       | 10                      | 11                       |
| 01                      | 00                       | 11                      | 10                       |
| 10                      | 11                       | 00                      | 01                       |
| 11                      | 10                       | 01                      | 00                       |

### Linear Burst Address Table

(MODE = GND)

| First Address<br>A1, A0 | Second Address<br>A1, A0 | Third Address<br>A1, A0 | Fourth Address<br>A1, A0 |
|-------------------------|--------------------------|-------------------------|--------------------------|
| 00                      | 01                       | 10                      | 11                       |
| 01                      | 10                       | 11                      | 00                       |
| 10                      | 11                       | 00                      | 01                       |
| 11                      | 00                       | 01                      | 10                       |

### ZZ Mode Electrical Characteristics

| Parameter   | Description                       | Test Conditions           | Min        | Max        | Unit |
|-------------|-----------------------------------|---------------------------|------------|------------|------|
| $I_{DDZZ}$  | Sleep mode standby current        | $ZZ \geq V_{DD} - 0.2 V$  | –          | 75         | mA   |
| $t_{ZZS}$   | Device operation to ZZ            | $ZZ \geq V_{DD} - 0.2 V$  | –          | $2t_{CYC}$ | ns   |
| $t_{ZZREC}$ | ZZ recovery time                  | $ZZ \leq 0.2 V$           | $2t_{CYC}$ | –          | ns   |
| $t_{ZZI}$   | ZZ active to sleep current        | This parameter is sampled | –          | $2t_{CYC}$ | ns   |
| $t_{RZZI}$  | ZZ inactive to exit sleep current | This parameter is sampled | 0          | –          | ns   |



## Truth Table

The Truth Table for CY7C1460KV33/CY7C1460KVE33/CY7C1462KVE33 follows. [1, 2, 3, 4, 5, 6, 7]

| Operation                     | Address Used | $\overline{\text{CE}}$ | ZZ | $\overline{\text{ADV/LD}}$ | $\overline{\text{WE}}$ | $\overline{\text{BW}}_x$ | $\overline{\text{OE}}$ | $\overline{\text{CEN}}$ | CLK | DQ           |
|-------------------------------|--------------|------------------------|----|----------------------------|------------------------|--------------------------|------------------------|-------------------------|-----|--------------|
| Deselect cycle                | None         | H                      | L  | L                          | X                      | X                        | X                      | L                       | L-H | Tristate     |
| Continue deselect cycle       | None         | X                      | L  | H                          | X                      | X                        | X                      | L                       | L-H | Tristate     |
| Read cycle (begin burst)      | External     | L                      | L  | L                          | H                      | X                        | L                      | L                       | L-H | Data out (Q) |
| Read cycle (continue burst)   | Next         | X                      | L  | H                          | X                      | X                        | L                      | L                       | L-H | Data out (Q) |
| NOP/dummy read (begin burst)  | External     | L                      | L  | L                          | H                      | X                        | H                      | L                       | L-H | Tristate     |
| Dummy read (continue burst)   | Next         | X                      | L  | H                          | X                      | X                        | H                      | L                       | L-H | Tristate     |
| Write cycle (begin burst)     | External     | L                      | L  | L                          | L                      | L                        | X                      | L                       | L-H | Data in (D)  |
| Write cycle (continue burst)  | Next         | X                      | L  | H                          | X                      | L                        | X                      | L                       | L-H | Data in (D)  |
| NOP/WRITE ABORT (begin burst) | None         | L                      | L  | L                          | L                      | H                        | X                      | L                       | L-H | Tristate     |
| WRITE ABORT (continue burst)  | Next         | X                      | L  | H                          | X                      | H                        | X                      | L                       | L-H | Tristate     |
| IGNORE CLOCK EDGE (stall)     | Current      | X                      | L  | X                          | X                      | X                        | X                      | H                       | L-H | -            |
| SLEEP MODE                    | None         | X                      | H  | X                          | X                      | X                        | X                      | X                       | X   | Tristate     |

### Notes

1. X = "Don't Care", H = Logic HIGH, L = Logic LOW,  $\overline{\text{CE}}$  stands for all chip enables active.  $\overline{\text{BW}}_x = \text{L}$  signifies at least one byte write select is active,  $\overline{\text{BW}}_x = \text{valid}$  signifies that the desired byte write selects are asserted, see Write Cycle Description table for details.
2. Write is defined by  $\overline{\text{WE}}$  and  $\overline{\text{BW}}_x$ . See Write Cycle Description table for details.
3. When a write cycle is detected, all I/Os are tristated, even during byte writes.
4. The DQ and DQP pins are controlled by the current cycle and the  $\overline{\text{OE}}$  signal.
5.  $\overline{\text{CEN}} = \text{H}$  inserts wait states.
6. Device powers up deselected and the I/Os in a tristate condition, regardless of  $\overline{\text{OE}}$ .
7.  $\overline{\text{OE}}$  is asynchronous and is not sampled with the clock rise. It is masked internally during write cycles. During a read cycle  $\text{DQ}_s$  and  $\text{DQP}_x = \text{Tristate}$  when  $\overline{\text{OE}}$  is inactive or when the device is deselected, and  $\text{DQ}_s = \text{data}$  when  $\overline{\text{OE}}$  is active.



## Partial Write Cycle Description

The Partial Write Cycle Description for CY7C1460KV33/CY7C1460KVE33 follows. [8, 9, 10, 11]

| Function (CY7C1460KV33/CY7C1460KVE33)                  | $\overline{WE}$ | $\overline{BW}_d$ | $\overline{BW}_c$ | $\overline{BW}_b$ | $\overline{BW}_a$ |
|--|-----------------|-------------------|-------------------|-------------------|-------------------|
| Read   | H               | X                 | X                 | X                 | X                 |
| Write – no bytes written                               | L               | H                 | H                 | H                 | H                 |
| Write byte a – (DQ <sub>a</sub> and DQP <sub>a</sub> ) | L               | H                 | H                 | H                 | L                 |
| Write byte b – (DQ <sub>b</sub> and DQP <sub>b</sub> ) | L               | H                 | H                 | L                 | H                 |
| Write bytes b, a                                       | L               | H                 | H                 | L                 | L                 |
| Write byte c – (DQ <sub>c</sub> and DQP <sub>c</sub> ) | L               | H                 | L                 | H                 | H                 |
| Write bytes c, a                                       | L               | H                 | L                 | H                 | L                 |
| Write bytes c, b                                       | L               | H                 | LL                | L                 | H                 |
| Write bytes c, b, a                                    | L               | H                 | L                 | L                 | L                 |
| Write byte d – (DQ <sub>d</sub> and DQP <sub>d</sub> ) | L               | L                 | H                 | H                 | H                 |
| Write bytes d, a                                       | L               | L                 | H                 | H                 | L                 |
| Write bytes d, b                                       | L               | L                 | H                 | L                 | H                 |
| Write bytes d, b, a                                    | L               | L                 | H                 | L                 | L                 |
| Write bytes d, c                                       | L               | L                 | L                 | H                 | H                 |
| Write bytes d, c, a                                    | L               | L                 | L                 | H                 | L                 |
| Write bytes d, c, b                                    | L               | L                 | L                 | L                 | H                 |
| Write all bytes  | L               | L                 | L                 | L                 | L                 |

## Partial Write Cycle Description

The Partial Write Cycle Description for CY7C1462KVE33 follows. [9, 11]

| Function (CY7C1462KVE33)                               | $\overline{WE}$ | $\overline{BW}_b$ | $\overline{BW}_a$ |
|--|-----------------|-------------------|-------------------|
| Read   | H               | x                 | x                 |
| Write – no bytes written                               | L               | H                 | H                 |
| Write byte a – (DQ <sub>a</sub> and DQP <sub>a</sub> ) | L               | H                 | L                 |
| Write byte b – (DQ <sub>b</sub> and DQP <sub>b</sub> ) | L               | L                 | H                 |
| Write both bytes                                       | L               | L                 | L                 |

### Notes

- X = "Don't Care", H = Logic HIGH, L = Logic LOW,  $\overline{CE}$  stands for all chip enables active.  $\overline{BW}_x = L$  signifies at least one byte write select is active,  $\overline{BW}_x = \text{valid}$  signifies that the desired byte write selects are asserted, see Write Cycle Description table for details.
- Write is defined by  $\overline{WE}$  and  $\overline{BW}_x$ . See Write Cycle Description table for details.
- When a write cycle is detected, all I/Os are tristated, even during byte writes.
- Table only lists partial byte write combinations. Any combination of  $\overline{BW}_{[a:d]}$  is valid. Appropriate write is done based on which byte write is active.



## IEEE 1149.1 Serial Boundary Scan (JTAG)

CY7C1460KVE33 incorporates a serial boundary scan test access port (TAP). This part is fully compliant with 1149.1. The TAP operates using JEDEC-standard 3.3-V or 2.5-V I/O logic level.

The CY7C1460KVE33 contains a TAP controller, instruction register, boundary scan register, bypass register, and ID register.

### Disabling the JTAG Feature

It is possible to operate the SRAM without using the JTAG feature. To disable the TAP controller, TCK must be tied LOW ( $V_{SS}$ ) to prevent clocking of the device. TDI and TMS are pulled up internally and may be unconnected. They may alternately be connected to  $V_{DD}$  through a pull-up resistor. TDO should be left unconnected. Upon power-up, the device enters a reset state, which does not interfere with the operation of the device.

### Test Access Port (TAP)

#### Test Clock (TCK)

The test clock is used only with the TAP controller. All inputs are captured on the rising edge of TCK. All outputs are driven from the falling edge of TCK.

#### Test Mode Select (TMS)

The TMS input is used to give commands to the TAP controller and is sampled on the rising edge of TCK. It is allowable to leave this ball unconnected if the TAP is not used. The ball is pulled up internally, resulting in a logic HIGH level.

#### Test Data-In (TDI)

The TDI ball is used to serially input information into the registers and can be connected to the input of any of the registers. The register between TDI and TDO is chosen by the instruction that is loaded into the TAP instruction register. TDI is pulled up internally and can be unconnected if the TAP is unused in an application. TDI is connected to the most significant bit (MSB) of any register (see [TAP Controller Block Diagram](#)).

#### Test Data-Out (TDO)

The TDO output ball is used to serially clock data-out from the registers. The output is active depending upon the current state of the TAP state machine. The output changes on the falling edge of TCK. TDO is connected to the least significant bit (LSB) of any register (see [TAP Controller State Diagram](#)).

### Performing a TAP Reset

A RESET is performed by forcing TMS HIGH ( $V_{DD}$ ) for five rising edges of TCK. This RESET does not affect the operation of the SRAM and may be performed while the SRAM is operating.

At power-up, the TAP is reset internally to ensure that TDO comes up in a high-Z state.

### TAP Registers

Registers are connected between the TDI and TDO balls and allow data to be scanned into and out of the SRAM test circuitry. Only one register can be selected at a time through the instruction register. Data is serially loaded into the TDI ball on the rising edge of TCK. Data is output on the TDO ball on the falling edge of TCK.

#### Instruction Register

Three-bit instructions can be serially loaded into the instruction register. This register is loaded when it is placed between the TDI and TDO balls as shown in the [TAP Controller Block Diagram](#). Upon power-up, the instruction register is loaded with the IDCODE instruction. It is also loaded with the IDCODE instruction if the controller is placed in a reset state as described in the previous section.

When the TAP controller is in the Capture-IR state, the two least significant bits are loaded with a binary "01" pattern to enable fault isolation of the board-level serial test data path.

#### Bypass Register

To save time when serially shifting data through registers, it is sometimes advantageous to skip certain chips. The bypass register is a single-bit register that can be placed between the TDI and TDO balls. This allows data to be shifted through the SRAM with minimal delay. The bypass register is set LOW ( $V_{SS}$ ) when the BYPASS instruction is executed.

#### Boundary Scan Register

The boundary scan register is connected to all the input and bidirectional balls on the SRAM. The length of the boundary scan register for the SRAM in different packages is listed in the Scan Register Sizes table.

The boundary scan register is loaded with the contents of the RAM I/O ring when the TAP controller is in the Capture-DR state and is then placed between the TDI and TDO balls when the controller is moved to the Shift-DR state. The EXTEST, SAMPLE/PRELOAD and SAMPLE Z instructions can be used to capture the contents of the I/O ring.

The [Boundary Scan Order](#) on page 19 and show the order in which the bits are connected. Each bit corresponds to one of the bumps on the SRAM package. The MSB of the register is connected to TDI, and the LSB is connected to TDO.

#### Identification (ID) Register

The ID register is loaded with a vendor-specific, 32-bit code during the Capture-DR state when the IDCODE command is loaded in the instruction register. The IDCODE is hardwired into the SRAM and can be shifted out when the TAP controller is in the Shift-DR state. The ID register has a vendor code and other information described in the [Identification Register Definitions](#) on page 18.



## TAP Instruction Set

### Overview

Eight different instructions are possible with the three-bit instruction register. All combinations are listed in the Instruction Codes table. Three of these instructions are listed as RESERVED and should not be used. The other five instructions described in detail are as follows.

Instructions are loaded into the TAP controller during the Shift-IR state when the instruction register is placed between TDI and TDO. During this state, instructions are shifted through the instruction register through the TDI and TDO balls. To execute the instruction after it is shifted in, the TAP controller needs to be moved into the Update-IR state.

### IDCODE

The IDCODE instruction causes a vendor-specific, 32-bit code to be loaded into the instruction register. It also places the instruction register between the TDI and TDO balls and allows the IDCODE to be shifted out of the device when the TAP controller enters the Shift-DR state.

The IDCODE instruction is loaded into the instruction register upon power-up or whenever the TAP controller is given a test logic reset state.

### SAMPLE Z

The SAMPLE Z instruction causes the boundary scan register to be connected between the TDI and TDO pins when the TAP controller is in a Shift-DR state. The SAMPLE Z command puts the output bus into a high-Z state until the next command is given during the "Update IR" state.

### SAMPLE/PRELOAD

SAMPLE/PRELOAD is a 1149.1 mandatory instruction. When the SAMPLE/PRELOAD instructions are loaded into the instruction register and the TAP controller is in the Capture-DR state, a snapshot of data on the input and output pins is captured in the boundary scan register.

The user must be aware that the TAP controller clock can only operate at a frequency up to 20 MHz, while the SRAM clock operates more than an order of magnitude faster. Because there is a large difference in the clock frequencies, it is possible that during the Capture-DR state, an input or output undergoes a transition. The TAP may then try to capture a signal while in transition (metastable state). This does not harm the device, but there is no guarantee as to the value that is captured. Repeatable results may not be possible.

To guarantee that the boundary scan register captures the correct value of a signal, the SRAM signal must be stabilized long enough to meet the TAP controller's capture setup plus hold times ( $t_{CS}$  and  $t_{CH}$ ). The SRAM clock input might not be captured correctly if there is no way in a design to stop (or slow) the clock during a SAMPLE/PRELOAD instruction. If this is an issue, it is still possible to capture all other signals and simply ignore the value of the clock captured in the boundary scan register.

After the data is captured, it is possible to shift out the data by putting the TAP into the Shift-DR state. This places the boundary scan register between the TDI and TDO pins.

PRELOAD allows an initial data pattern to be placed at the latched parallel outputs of the boundary scan register cells prior to the selection of another boundary scan test operation.

The shifting of data for the SAMPLE and PRELOAD phases can occur concurrently when required – that is, while data captured is shifted out, the preloaded data can be shifted in.

### BYPASS

When the BYPASS instruction is loaded in the instruction register and the TAP is placed in a Shift-DR state, the bypass register is placed between the TDI and TDO pins. The advantage of the BYPASS instruction is that it shortens the boundary scan path when multiple devices are connected on a board.

### EXTEST

The EXTEST instruction enables the preloaded data to be driven out through the system output pins. This instruction also selects the boundary scan register to be connected for serial access between the TDI and TDO in the shift-DR controller state.

### EXTEST OUTPUT BUS TRISTATE

IEEE Standard 1149.1 mandates that the TAP controller must be able to put the output bus into a tristate mode.

The boundary scan register has a special bit located at bit #89 (for the 165-ball FBGA package). When this scan cell, called the "extest output bus tristate," is latched into the preload register during the "Update-DR" state in the TAP controller, it directly controls the state of the output (Q-bus) pins, when the EXTEST is entered as the current instruction. When HIGH, it enables the output buffers to drive the output bus. When LOW, this bit places the output bus in a high-Z condition.

This bit can be set by entering the SAMPLE/PRELOAD or EXTEST command, and then shifting the desired bit into that cell, during the "Shift-DR" state. During "Update-DR," the value loaded into that shift-register cell latches into the preload register. When the EXTEST instruction is entered, this bit directly controls the output Q-bus pins. Note that this bit is preset HIGH to enable the output when the device is powered-up, and also when the TAP controller is in the "Test-Logic-Reset" state.

### Reserved

These instructions are not implemented but are reserved for future use. Do not use these instructions.



### TAP Controller State Diagram

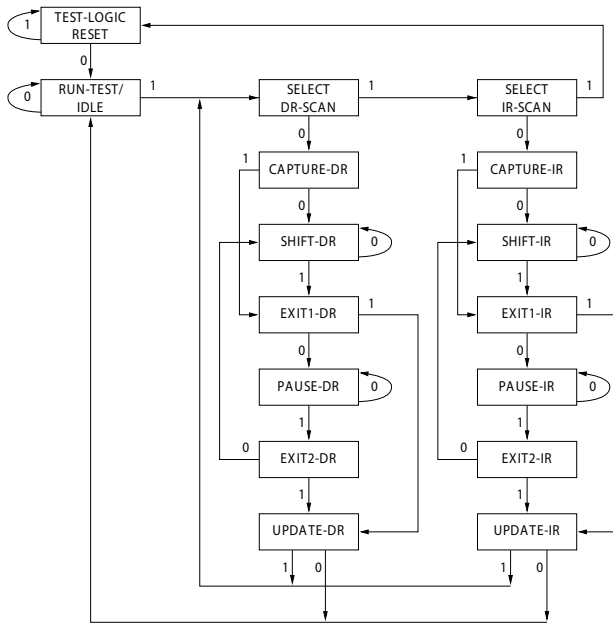

### TAP Controller Block Diagram

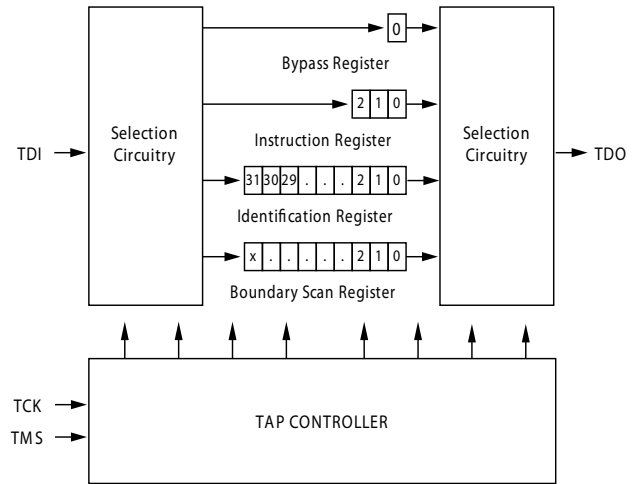

The 0/1 next to each state represents the value of TMS at the rising edge of TCK.

### TAP Timing Diagram

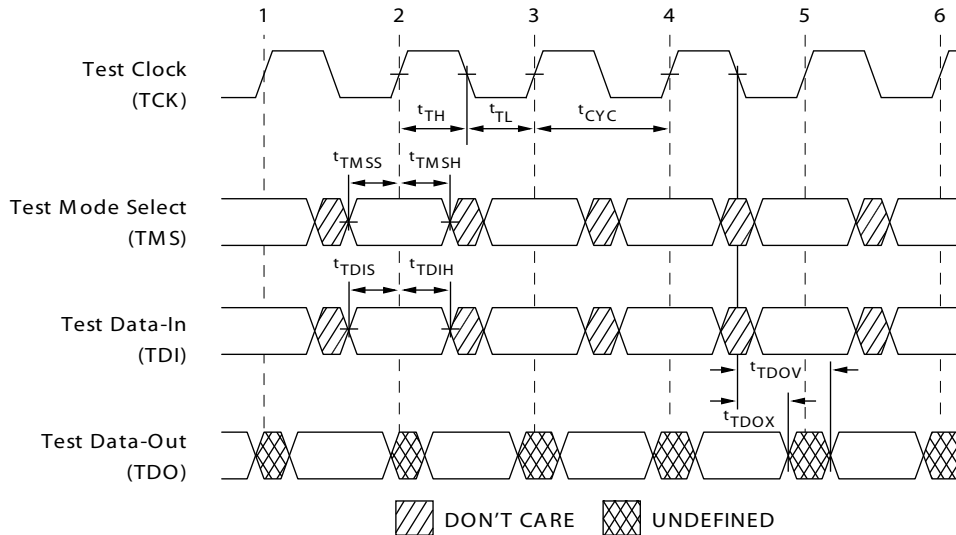



## TAP AC Switching Characteristics

Over the Operating Range

| Parameter <sup>[12, 13]</sup> | Description                   | Min | Max | Unit |
|-------------------------------|-------------------------------|-----|-----|------|
| <b>Clock</b>                  |                               |     |     |      |
| $t_{TCYC}$                    | TCK clock cycle time          | 50  | –   | ns   |
| $t_{TF}$                      | TCK clock frequency           | –   | 20  | MHz  |
| $t_{TH}$                      | TCK clock HIGH time           | 20  | –   | ns   |
| $t_{TL}$                      | TCK clock LOW time            | 20  | –   | ns   |
| <b>Output Times</b>           |                               |     |     |      |
| $t_{TDOV}$                    | TCK clock LOW to TDO valid    | –   | 10  | ns   |
| $t_{TDOX}$                    | TCK clock LOW to TDO invalid  | 0   | –   | ns   |
| <b>Setup Times</b>            |                               |     |     |      |
| $t_{TMSS}$                    | TMS setup to TCK clock rise   | 5   | –   | ns   |
| $t_{TDIS}$                    | TDI setup to TCK clock rise   | 5   | –   | ns   |
| $t_{CS}$                      | Capture setup to TCK rise     | 5   | –   | ns   |
| <b>Hold Times</b>             |                               |     |     |      |
| $t_{TMSh}$                    | TMS hold after TCK clock rise | 5   | –   | ns   |
| $t_{TDIH}$                    | TDI hold after clock rise     | 5   | –   | ns   |
| $t_{CH}$                      | Capture hold after clock rise | 5   | –   | ns   |

### Notes

12.  $t_{CS}$  and  $t_{CH}$  refer to the setup and hold time requirements of latching data from the boundary scan register.  
 13. Test conditions are specified using the load in TAP AC test Conditions.  $t_R/t_F = 2$  V/ns (Slew Rate).



### 3.3 V TAP AC Test Conditions

|   |                   |
|---|-------------------|
| Input pulse levels .....                    | $V_{SS}$ to 3.3 V |
| Input rise and fall times (Slew Rate) ..... | 2 V/ns            |
| Input timing reference levels .....         | 1.5 V             |
| Output reference levels .....               | 1.5 V             |
| Test load termination supply voltage .....  | 1.5 V             |

### 3.3 V TAP AC Output Load Equivalent

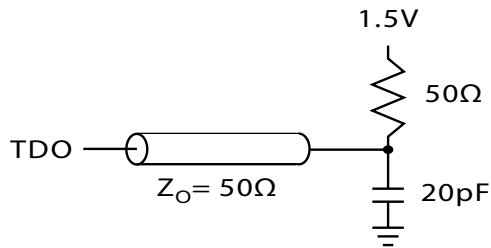

### 2.5 V TAP AC Test Conditions

|   |                   |
|---|-------------------|
| Input pulse levels .....                    | $V_{SS}$ to 2.5 V |
| Input rise and fall times (Slew Rate) ..... | 2 V/ns            |
| Input timing reference levels .....         | 1.25 V            |
| Output reference levels .....               | 1.25 V            |
| Test load termination supply voltage .....  | 1.25 V            |

### 2.5 V TAP AC Output Load Equivalent

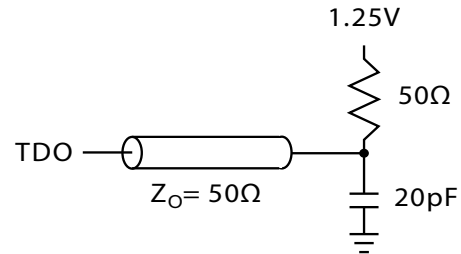

## TAP DC Electrical Characteristics and Operating Conditions

(0 °C < T<sub>A</sub> < +70 °C; V<sub>DD</sub> = 3.135 V to 3.6 V unless otherwise noted)

| Parameter <sup>[14]</sup> | Description         | Test Conditions                                     | Min                      | Max  | Unit                  |   |
|---------------------------|---------------------|---|--------------------------|------|-----------------------|---|
| V <sub>OH1</sub>          | Output HIGH voltage | I <sub>OH</sub> = -4.0 mA, V <sub>DDQ</sub> = 3.3 V | 2.4                      | -    | V                     |   |
|                           |                     | I <sub>OH</sub> = -1.0 mA, V <sub>DDQ</sub> = 2.5 V | 2.0                      | -    | V                     |   |
| V <sub>OH2</sub>          | Output HIGH voltage | I <sub>OH</sub> = -100 μA                           | V <sub>DDQ</sub> = 3.3 V | 2.9  | -                     | V |
|                           |                     |   | V <sub>DDQ</sub> = 2.5 V | 2.1  | -                     | V |
| V <sub>OL1</sub>          | Output LOW voltage  | I <sub>OL</sub> = 8.0 mA                            | V <sub>DDQ</sub> = 3.3 V | -    | 0.4                   | V |
|                           |                     | I <sub>OL</sub> = 1.0 mA                            | V <sub>DDQ</sub> = 2.5 V | -    | 0.4                   | V |
| V <sub>OL2</sub>          | Output LOW voltage  | I <sub>OL</sub> = 100 μA                            | V <sub>DDQ</sub> = 3.3 V | -    | 0.2                   | V |
|                           |                     |   | V <sub>DDQ</sub> = 2.5 V | -    | 0.2                   | V |
| V <sub>IH</sub>           | Input HIGH voltage  | -   | V <sub>DDQ</sub> = 3.3 V | 2.0  | V <sub>DD</sub> + 0.3 | V |
|                           |                     |   | V <sub>DDQ</sub> = 2.5 V | 1.7  | V <sub>DD</sub> + 0.3 | V |
| V <sub>IL</sub>           | Input LOW voltage   | -   | V <sub>DDQ</sub> = 3.3 V | -0.3 | 0.8                   | V |
|                           |                     |   | V <sub>DDQ</sub> = 2.5 V | -0.3 | 0.7                   | V |
| I <sub>X</sub>            | Input load current  | GND ≤ V <sub>IN</sub> ≤ V <sub>DDQ</sub>            | -5                       | 5    | μA                    |   |

#### Notes

14. All voltages referenced to V<sub>SS</sub> (GND).

15. Bit #24 is "1" in the ID Register Definitions for both 2.5-V and 3.3-V versions of this device.



## Identification Register Definitions

| Instruction Field                    | CY7C1460KVE33<br>(1M x 36) | Description                                  |
|--------------------------------------|----------------------------|--|
| Revision number (31:29)              | 000                        | Describes the version number.                |
| Device depth (28:24) <sup>[15]</sup> | 01011                      | Reserved for internal use                    |
| Architecture/memory type(23:18)      | 001000                     | Defines memory type and architecture         |
| Bus width/density(17:12)             | 100111                     | Defines width and density                    |
| Cypress JEDEC ID code (11:1)         | 00000110100                | Allows unique identification of SRAM vendor. |
| ID register presence indicator (0)   | 1                          | Indicates the presence of an ID register.    |

## Scan Register Sizes

| Register Name                               | Bit Size (x 36) |
|---|-----------------|
| Instruction                                 | 3               |
| Bypass                                      | 1               |
| ID  | 32              |
| Boundary scan order (165-ball FBGA package) | 89              |

## Identification Codes

| Instruction    | Code | Description  |
|----------------|------|--|
| EXTTEST        | 000  | Captures I/O ring contents. Places the boundary scan register between TDI and TDO. Forces all SRAM outputs to high Z state.                |
| IDCODE         | 001  | Loads the ID register with the vendor ID code and places the register between TDI and TDO. This operation does not affect SRAM operations. |
| SAMPLE Z       | 010  | Captures I/O ring contents. Places the boundary scan register between TDI and TDO. Forces all SRAM output drivers to a high Z state.       |
| RESERVED       | 011  | Do Not Use: This instruction is reserved for future use.   |
| SAMPLE/PRELOAD | 100  | Captures I/O ring contents. Places the boundary scan register between TDI and TDO. Does not affect SRAM operation.                         |
| RESERVED       | 101  | Do Not Use: This instruction is reserved for future use.   |
| RESERVED       | 110  | Do Not Use: This instruction is reserved for future use.   |
| BYPASS         | 111  | Places the bypass register between TDI and TDO. This operation does not affect SRAM operations.  |



## Boundary Scan Order

165-ball FBGA <sup>[16]</sup>

### CY7C1460KVE33 (1M × 36)

| Bit# | ball ID | Bit# | ball ID | Bit# | ball ID | Bit# | ball ID  |
|------|---------|------|---------|------|---------|------|----------|
| 1    | N6      | 26   | E11     | 51   | A3      | 76   | N1       |
| 2    | N7      | 27   | D11     | 52   | A2      | 77   | N2       |
| 3    | 10N     | 28   | G10     | 53   | B2      | 78   | P1       |
| 4    | P11     | 29   | F10     | 54   | C2      | 79   | R1       |
| 5    | P8      | 30   | E10     | 55   | B1      | 80   | R2       |
| 6    | R8      | 31   | D10     | 56   | A1      | 81   | P3       |
| 7    | R9      | 32   | C11     | 57   | C1      | 82   | R3       |
| 8    | P9      | 33   | A11     | 58   | D1      | 83   | P2       |
| 9    | P10     | 34   | B11     | 59   | E1      | 84   | R4       |
| 10   | R10     | 35   | A10     | 60   | F1      | 85   | P4       |
| 11   | R11     | 36   | B10     | 61   | G1      | 86   | N5       |
| 12   | H11     | 37   | A9      | 62   | D2      | 87   | P6       |
| 13   | N11     | 38   | B9      | 63   | E2      | 88   | R6       |
| 14   | M11     | 39   | C10     | 64   | F2      | 89   | Internal |
| 15   | L11     | 40   | A8      | 65   | G2      |      |          |
| 16   | K11     | 41   | B8      | 66   | H1      |      |          |
| 17   | J11     | 42   | A7      | 67   | H3      |      |          |
| 18   | M10     | 43   | B7      | 68   | J1      |      |          |
| 19   | L10     | 44   | B6      | 69   | K1      |      |          |
| 20   | K10     | 45   | A6      | 70   | L1      |      |          |
| 21   | J10     | 46   | B5      | 71   | M1      |      |          |
| 22   | H9      | 47   | A5      | 72   | J2      |      |          |
| 23   | H10     | 48   | A4      | 73   | K2      |      |          |
| 24   | G11     | 49   | B4      | 74   | L2      |      |          |
| 25   | F11     | 50   | B3      | 75   | M2      |      |          |

#### Note

16. Bit# 89 is preset HIGH.



## Maximum Ratings

Exceeding maximum ratings may shorten the useful life of the device. User guidelines are not tested.

Storage temperature ..... -65 °C to +150 °C

Ambient temperature with power applied ..... -55 °C to +125 °C

Supply voltage on  $V_{DD}$  relative to GND ..... -0.5 V to +4.6 V

Supply voltage on  $V_{DDQ}$  relative to GND ..... -0.5 V to + $V_{DD}$

DC to outputs in tri-state ..... -0.5 V to  $V_{DDQ} + 0.5$  V

DC input voltage ..... -0.5 V to  $V_{DD} + 0.5$  V

Current into outputs (LOW) ..... 20 mA

Static discharge voltage (per MIL-STD-883, method 3015) ..... > 2001 V

Latch-up current ..... > 200 mA

## Operating Range

| Range      | Ambient Temperature | $V_{DD}$           | $V_{DDQ}$              |
|------------|---------------------|--------------------|------------------------|
| Commercial | 0 °C to +70 °C      | 3.3 V – 5% / + 10% | 2.5 V – 5% to $V_{DD}$ |
| Industrial | –40 °C to +85 °C    |                    |                        |

## Neutron Soft Error Immunity

| Parameter                 | Description               | Test Conditions | Typ | Max* | Unit    |
|---------------------------|---------------------------|-----------------|-----|------|---------|
| LSBU (Device without ECC) | Logical Single-Bit Upsets | 25 °C           | <5  | 5    | FIT/Mb  |
|                           |                           |                 | 0   | 0.01 | FIT/Mb  |
| LMBU (All Devices)        | Logical Multi-Bit Upsets  | 25 °C           | 0   | 0.01 | FIT/Mb  |
| SEL (All Devices)         | Single Event Latch up     | 85 °C           | 0   | 0.1  | FIT/Dev |

\* No LMBU or SEL events occurred during testing; this column represents a statistical  $\chi^2$ , 95% confidence limit calculation. For more details refer to Application Note AN 54908 "Accelerated Neutron SER Testing and Calculation of Terrestrial Failure Rates"

## Electrical Characteristics

Over the Operating Range

| Parameter <sup>[17, 18]</sup> | Description                        | Test Conditions                   | Min   | Max              | Unit |
|-------------------------------|------------------------------------|-----------------------------------|-------|------------------|------|
| $V_{DD}$                      | Power supply voltage               |                                   | 3.135 | 3.6              | V    |
| $V_{DDQ}$                     | I/O supply voltage                 | for 3.3 V I/O                     | 3.135 | $V_{DD}$         | V    |
|                               |                                    | for 2.5 V I/O                     | 2.375 | 2.625            | V    |
| $V_{OH}$                      | Output HIGH voltage                | for 3.3 V I/O, $I_{OH} = -4.0$ mA | 2.4   | –                | V    |
|                               |                                    | for 2.5 V I/O, $I_{OH} = -1.0$ mA | 2.0   | –                | V    |
| $V_{OL}$                      | Output LOW voltage                 | for 3.3 V I/O, $I_{OL} = 8.0$ mA  | –     | 0.4              | V    |
|                               |                                    | for 2.5 V I/O, $I_{OL} = 1.0$ mA  | –     | 0.4              | V    |
| $V_{IH}$                      | Input HIGH voltage <sup>[17]</sup> | for 3.3 V I/O                     | 2.0   | $V_{DD} + 0.3$ V | V    |
|                               |                                    | for 2.5 V I/O                     | 1.7   | $V_{DD} + 0.3$ V | V    |
| $V_{IL}$                      | Input LOW voltage <sup>[17]</sup>  | for 3.3 V I/O                     | –0.3  | 0.8              | V    |
|                               |                                    | for 2.5 V I/O                     | –0.3  | 0.7              | V    |

### Notes

17. Overshoot:  $V_{IH}(AC) < V_{DD} + 1.5$  V (Pulse width less than  $t_{CYC}/2$ ), undershoot:  $V_{IL}(AC) > -2$  V (Pulse width less than  $t_{CYC}/2$ ).

18.  $T_{power\ up}$ : Assumes a linear ramp from 0 V to  $V_{DD}$  (Min) within 200 ms. During this time  $V_{IH} < V_{DD}$  and  $V_{DDQ} \leq V_{DD}$ .

**Electrical Characteristics** (continued)

Over the Operating Range

| Parameter <sup>[17, 18]</sup> | Description                                   | Test Conditions   | Min                    | Max         | Unit    |     |    |
|-------------------------------|---|---|------------------------|-------------|---------|-----|----|
| $I_X$                         | Input leakage current except ZZ and MODE      | $GND \leq V_I \leq V_{DDQ}$   | -5                     | 5           | $\mu A$ |     |    |
|                               | Input current of MODE                         | Input = $V_{SS}$  | -30                    | -           | $\mu A$ |     |    |
|                               |   | Input = $V_{DD}$  | -                      | 5           | $\mu A$ |     |    |
|                               | Input current of ZZ                           | Input = $V_{SS}$  | -5                     | -           | $\mu A$ |     |    |
| Input = $V_{DD}$              |   | -   | 30                     | $\mu A$     |         |     |    |
| $I_{OZ}$                      | Output leakage current                        | $GND \leq V_I \leq V_{DDQ}$ , output disabled   | -5                     | 5           | $\mu A$ |     |    |
| $I_{DD}$                      | $V_{DD}$ operating supply                     | $V_{DD} = \text{Max}$ , $I_{OUT} = 0 \text{ mA}$ ,<br>$f = f_{MAX} = 1/t_{CYC}$   | 4-ns cycle,<br>250 MHz | $\times 18$ | -       | 220 | mA |
|                               |   |   |                        | $\times 36$ | -       | 240 |    |
|                               |   |   | 5-ns cycle,<br>200 MHz | $\times 18$ | -       | 190 | mA |
|                               |   |   |                        | $\times 36$ | -       | 210 |    |
|                               |   |   | 6-ns cycle,<br>167 MHz | $\times 18$ | -       | 170 | mA |
|                               |   |   |                        | $\times 36$ | -       | 190 |    |
| $I_{SB1}$                     | Automatic CE power-down current – TTL inputs  | Max $V_{DD}$ ,<br>device deselected,<br>$V_{IN} \geq V_{IH}$ or $V_{IN} \leq V_{IL}$ ,<br>$f = f_{MAX} = 1/t_{CYC}$                         | 4-ns cycle,<br>250 MHz | $\times 18$ | -       | 85  | mA |
|                               |   |   |                        | $\times 36$ | -       | 90  |    |
|                               |   |   | 5-ns cycle,<br>200 MHz | $\times 18$ | -       | 85  | mA |
|                               |   |   |                        | $\times 36$ | -       | 90  |    |
|                               |   |   | 6-ns cycle,<br>167 MHz | $\times 18$ | -       | 85  | mA |
|                               |   |   |                        | $\times 36$ | -       | 90  |    |
| $I_{SB2}$                     | Automatic CE power-down current – CMOS inputs | Max $V_{DD}$ ,<br>device deselected,<br>$V_{IN} \leq 0.3 \text{ V}$ or<br>$V_{IN} \geq V_{DDQ} - 0.3 \text{ V}$ ,<br>$f = 0$                | All speed grades       | $\times 18$ | -       | 75  | mA |
|                               |   |   |                        | $\times 36$ | -       | 80  |    |
| $I_{SB3}$                     | Automatic CE power-down current – CMOS inputs | Max $V_{DD}$ , device deselected,<br>$V_{IN} \leq 0.3 \text{ V}$ or<br>$V_{IN} \geq V_{DDQ} - 0.3 \text{ V}$ ,<br>$f = f_{MAX} = 1/t_{CYC}$ | 4-ns cycle,<br>250 MHz | $\times 18$ | -       | 85  | mA |
|                               |   |   |                        | $\times 36$ | -       | 90  |    |
|                               |   |   | 5-ns cycle,<br>200 MHz | $\times 18$ | -       | 85  | mA |
|                               |   |   |                        | $\times 36$ | -       | 90  |    |
|                               |   |   | 6-ns cycle,<br>167 MHz | $\times 18$ | -       | 85  | mA |
|                               |   |   |                        | $\times 36$ | -       | 90  |    |
| $I_{SB4}$                     | Automatic CE power-down current – TTL inputs  | Max $V_{DD}$ , device deselected,<br>$V_{IN} \geq V_{IH}$ or $V_{IN} \leq V_{IL}$ ,<br>$f = 0$  | All speed grades       | $\times 18$ | -       | 75  | mA |
|                               |   |   |                        | $\times 36$ | -       | 80  |    |



## Capacitance

| Parameter <sup>[19]</sup> | Description              | Test Conditions   | 100-pin TQFP Max | 165-ball FBGA Max | Unit |
|---------------------------|--------------------------|---|------------------|-------------------|------|
| $C_{IN}$                  | Input capacitance        | $T_A = 25\text{ }^\circ\text{C}$ , $f = 1\text{ MHz}$ ,<br>$V_{DD} = 3.3\text{ V}$ , $V_{DDQ} = 2.5\text{ V}$ | 5                | 5                 | pF   |
| $C_{CLK}$                 | Clock input capacitance  |   | 5                | 5                 | pF   |
| $C_{I/O}$                 | Input/output capacitance |   | 5                | 5                 | pF   |

## Thermal Resistance

| Parameter <sup>[19]</sup> | Description                              | Test Conditions  | 100-pin TQFP Package   | 165-ball FBGA Package | Unit               |                    |
|---------------------------|--|--|------------------------|-----------------------|--------------------|--------------------|
| $\Theta_{JA}$             | Thermal resistance (junction to ambient) | Test conditions follow standard test methods and procedures for measuring thermal impedance, per EIA/JESD51. | With Still Air (0 m/s) | 35.36                 | 14.24              | $^\circ\text{C/W}$ |
|                           |  |  | With Air Flow (1 m/s)  | 31.30                 | 12.47              | $^\circ\text{C/W}$ |
|                           |  |  | With Air Flow (3 m/s)  | 28.86                 | 11.40              | $^\circ\text{C/W}$ |
| $\Theta_{JC}$             | Thermal resistance (junction to case)    | –  | 7.52                   | 3.92                  | $^\circ\text{C/W}$ |                    |
| $\Theta_{JB}$             | Thermal resistance (junction to board)   | –  | 28.89                  | 7.19                  | $^\circ\text{C/W}$ |                    |

## AC Test Loads and Waveforms

Figure 3. AC Test Loads and Waveforms

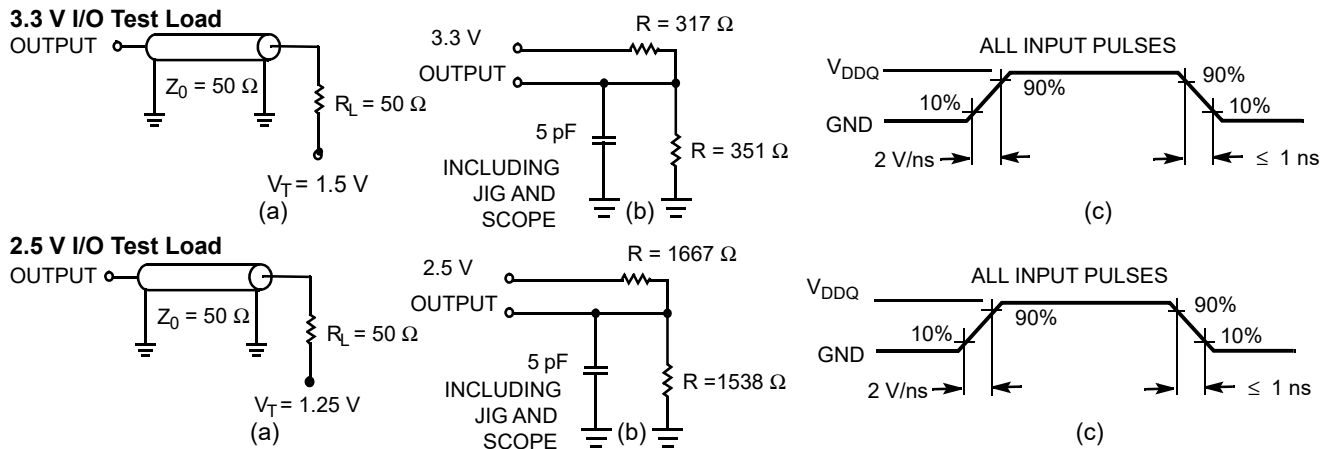

### Note

19. Tested initially and after any design or process changes that may affect these parameters.



## Switching Characteristics

Over the Operating Range

| Parameter <sup>[20, 21]</sup> | Description   | -250 |     | -200 |     | -167 |     | Unit |
|-------------------------------|---|------|-----|------|-----|------|-----|------|
|                               |   | Min  | Max | Min  | Max | Min  | Max |      |
| $t_{Power}$ <sup>[22]</sup>   | $V_{CC}$ (typical) to the first access read or write          | 1    | –   | 1    | –   | 1    | –   | ms   |
| <b>Clock</b>                  |   |      |     |      |     |      |     |      |
| $t_{CYC}$                     | Clock cycle time  | 4.0  | –   | 5.0  | –   | 6.0  | –   | ns   |
| $F_{MAX}$                     | Maximum operating frequency                                   | –    | 250 | –    | 200 | –    | 167 | MHz  |
| $t_{CH}$                      | Clock HIGH  | 1.5  | –   | 2.0  | –   | 2.4  | –   | ns   |
| $t_{CL}$                      | Clock LOW   | 1.5  | –   | 2.0  | –   | 2.4  | –   | ns   |
| <b>Output Times</b>           |   |      |     |      |     |      |     |      |
| $t_{CO}$                      | Data output valid after CLK rise                              | –    | 2.5 | –    | 3.2 | –    | 3.4 | ns   |
| $t_{EOV}$                     | $\overline{OE}$ LOW to output valid                           | –    | 2.6 | –    | 3.0 | –    | 3.4 | ns   |
| $t_{DOH}$                     | Data output hold after CLK rise                               | 1.0  | –   | 1.5  | –   | 1.5  | –   | ns   |
| $t_{CHZ}$                     | Clock to high Z <sup>[23, 24, 25]</sup>                       | –    | 2.6 | –    | 3.0 | –    | 3.4 | ns   |
| $t_{CLZ}$                     | Clock to low Z <sup>[23, 24, 25]</sup>                        | 1.0  | –   | 1.3  | –   | 1.5  | –   | ns   |
| $t_{EOHZ}$                    | $\overline{OE}$ HIGH to output high Z <sup>[23, 24, 25]</sup> | –    | 2.6 | –    | 3.0 | –    | 3.4 | ns   |
| $t_{EOLZ}$                    | $\overline{OE}$ LOW to output low Z <sup>[23, 24, 25]</sup>   | 0    | –   | 0    | –   | 0    | –   | ns   |
| <b>Setup Times</b>            |   |      |     |      |     |      |     |      |
| $t_{AS}$                      | Address setup before CLK rise                                 | 1.2  | –   | 1.4  | –   | 1.5  | –   | ns   |
| $t_{DS}$                      | Data input setup before CLK rise                              | 1.2  | –   | 1.4  | –   | 1.5  | –   | ns   |
| $t_{CENS}$                    | $\overline{CEN}$ setup before CLK rise                        | 1.2  | –   | 1.4  | –   | 1.5  | –   | ns   |
| $t_{WES}$                     | $\overline{WE}$ , $\overline{BW}_x$ setup before CLK rise     | 1.2  | –   | 1.4  | –   | 1.5  | –   | ns   |
| $t_{ALS}$                     | $\overline{ADV}/\overline{LD}$ setup before CLK rise          | 1.2  | –   | 1.4  | –   | 1.5  | –   | ns   |
| $t_{CES}$                     | Chip select setup   | 1.2  | –   | 1.4  | –   | 1.5  | –   | ns   |
| <b>Hold Times</b>             |   |      |     |      |     |      |     |      |
| $t_{AH}$                      | Address hold after CLK rise                                   | 0.3  | –   | 0.4  | –   | 0.5  | –   | ns   |
| $t_{DH}$                      | Data input hold after CLK rise                                | 0.3  | –   | 0.4  | –   | 0.5  | –   | ns   |
| $t_{CENH}$                    | $\overline{CEN}$ hold after CLK rise                          | 0.3  | –   | 0.4  | –   | 0.5  | –   | ns   |
| $t_{WEH}$                     | $\overline{WE}$ , $\overline{BW}_x$ hold after CLK rise       | 0.3  | –   | 0.4  | –   | 0.5  | –   | ns   |
| $t_{ALH}$                     | $\overline{ADV}/\overline{LD}$ hold after CLK rise            | 0.3  | –   | 0.4  | –   | 0.5  | –   | ns   |
| $t_{CEH}$                     | Chip select hold after CLK rise                               | 0.3  | –   | 0.4  | –   | 0.5  | –   | ns   |

### Notes

20. Timing reference is 1.5 V when  $V_{DDQ} = 3.3$  V and is 1.25 V when  $V_{DDQ} = 2.5$  V.

21. Test conditions shown in (a) of [Figure 3 on page 22](#) unless otherwise noted.

22. This part has a voltage regulator internally;  $t_{Power}$  is the time power needs to be supplied above  $V_{DD}$  minimum initially, before a Read or Write operation can be initiated.

23.  $t_{CHZ}$ ,  $t_{CLZ}$ ,  $t_{EOLZ}$ , and  $t_{EOHZ}$  are specified with AC test conditions shown in (b) of [Figure 3 on page 22](#). Transition is measured  $\pm 200$  mV from steady-state voltage.

24. At any voltage and temperature,  $t_{EOHZ}$  is less than  $t_{EOLZ}$  and  $t_{CHZ}$  is less than  $t_{CLZ}$  to eliminate bus contention between SRAMs when sharing the same data bus.

These specifications do not imply a bus contention condition, but reflect parameters guaranteed over worst case user conditions. Device is designed to achieve high Z prior to low Z under the same system conditions.

25. This parameter is sampled and not 100% tested.



## Switching Waveforms

Figure 4. Read/Write/Timing [26, 27, 28]

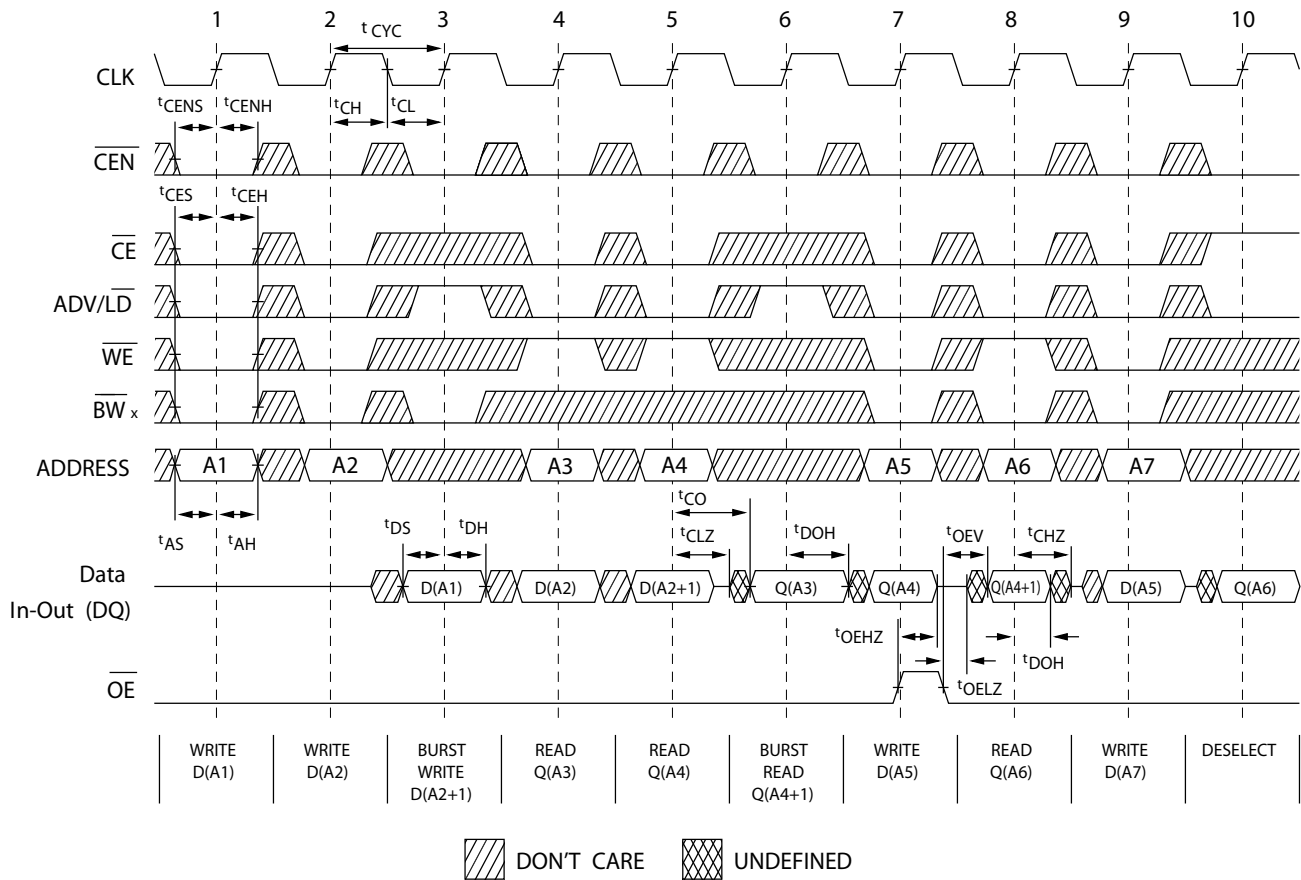

**Notes**

- 26. For this waveform ZZ is tied low.
- 27. When  $\overline{CE}$  is LOW,  $\overline{CE}_1$  is LOW,  $\overline{CE}_2$  is HIGH and  $\overline{CE}_3$  is LOW. When  $\overline{CE}$  is HIGH,  $\overline{CE}_1$  is HIGH or  $\overline{CE}_2$  is LOW or  $\overline{CE}_3$  is HIGH.
- 28. Order of the burst sequence is determined by the status of the MODE (0 = Linear, 1 = Interleaved). Burst operations are optional.



## Switching Waveforms (continued)

**Figure 5. NOP, STALL and DESELECT Cycles** [29, 30, 31]

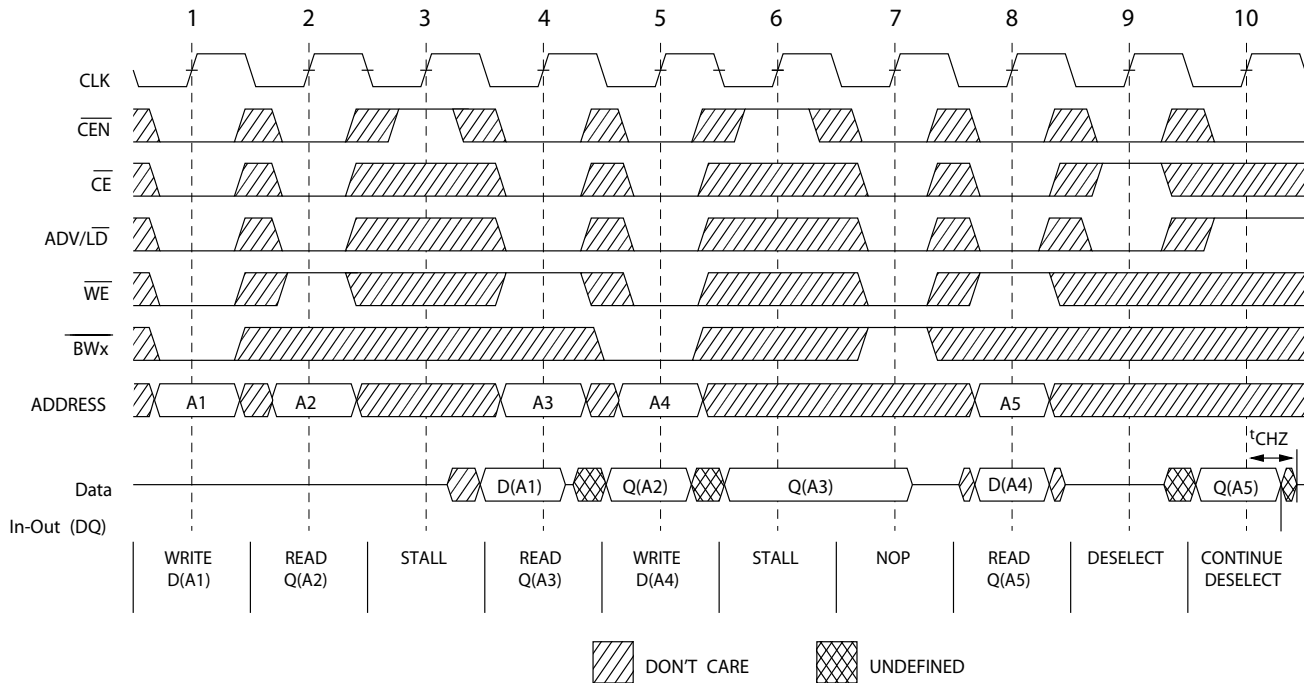

**Figure 6. ZZ Mode Timing** [32, 33]

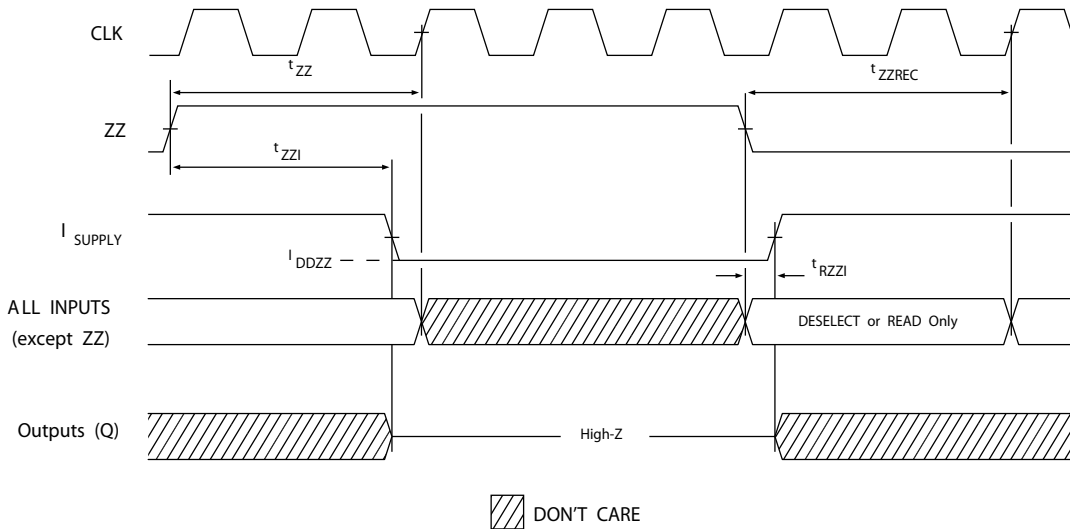

### Notes

29. For this waveform ZZ is tied low.

30. When CE is LOW, CE<sub>1</sub> is LOW, CE<sub>2</sub> is HIGH and CE<sub>3</sub> is LOW. When CE is HIGH, CE<sub>1</sub> is HIGH or CE<sub>2</sub> is LOW or CE<sub>3</sub> is HIGH.

31. The IGNORE CLOCK EDGE or STALL cycle (Clock 3) illustrated CEN being used to create a pause. A write is not performed during this cycle.

32. Device must be deselected when entering ZZ mode. See cycle description table for all possible signal conditions to deselect the device.

33. I/Os are in high Z when exiting ZZ sleep mode.



## Ordering Information

Table 1 lists the ordering codes. The table contains only the parts that are currently available. If you do not see what you are looking for, contact your local sales representative. For more information, visit the Cypress website at [www.cypress.com](http://www.cypress.com) and refer to the product summary page at <http://www.cypress.com/products>.

**Table 1. Ordering Information**

| Speed (MHz)         | Ordering Code        | Package Diagram | Part and Package Type                   | Operating Range |            |
|---------------------|----------------------|-----------------|---|-----------------|------------|
| 250                 | CY7C1460KV33-250AXI  | 51-85050        | 100-pin TQFP (14 × 20 × 1.4 mm) Pb-free | Industrial      |            |
| 200                 | CY7C1460KV33-200AXC  |                 |   | Commercial      |            |
|                     | CY7C1460KVE33-200AXC |                 |   |                 |            |
| 167                 | CY7C1460KV33-167AXC  |                 |   |                 |            |
|                     | CY7C1460KV33-167AXI  |                 |   |                 | Industrial |
|                     | CY7C1460KVE33-167AXI |                 |   |                 |            |
|                     | CY7C1460KVE33-167BZC | 51-85195        | 165-ball FBGA (15 × 17 × 1.4 mm)        | Commercial      |            |
| CY7C1460KV33-167BZC |                      |                 |   |                 |            |
|                     | CY7C1462KVE33-167AXC | 51-85050        | 100-pin TQFP (14 × 20 × 1.4 mm) Pb-free |                 |            |

## Ordering Code Definitions

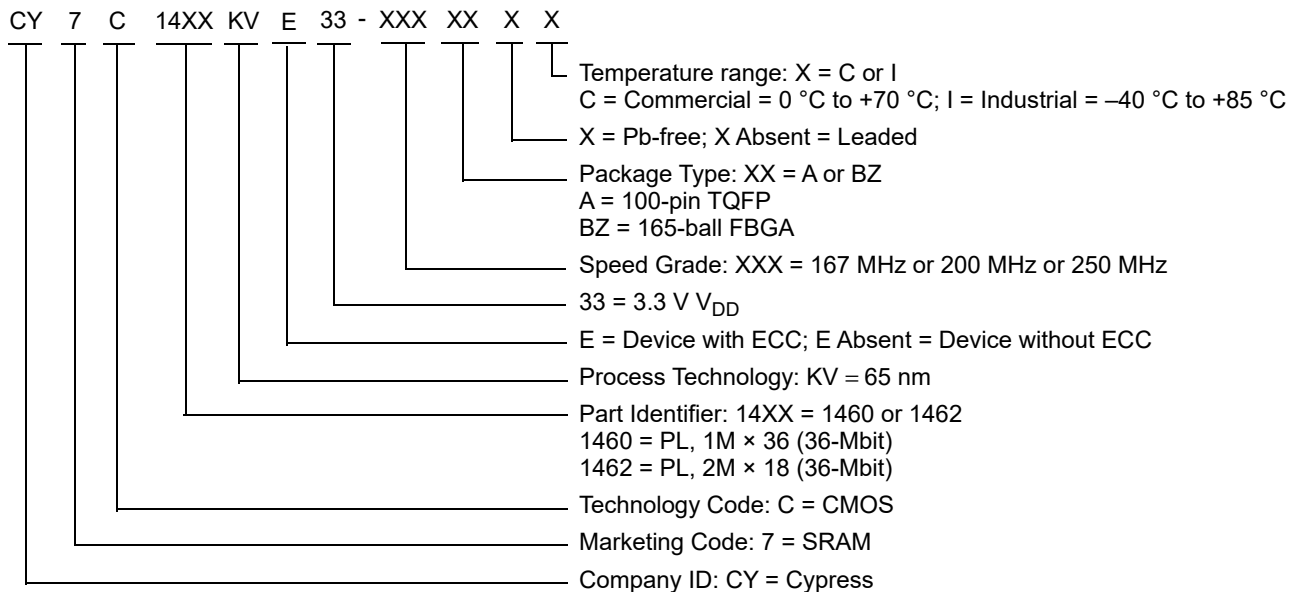





**Package Diagrams** (continued)

**Figure 8. 165-ball FBGA (15 × 17 × 1.4 mm (0.5 Ball Diameter)) Package Outline, 51-85195**

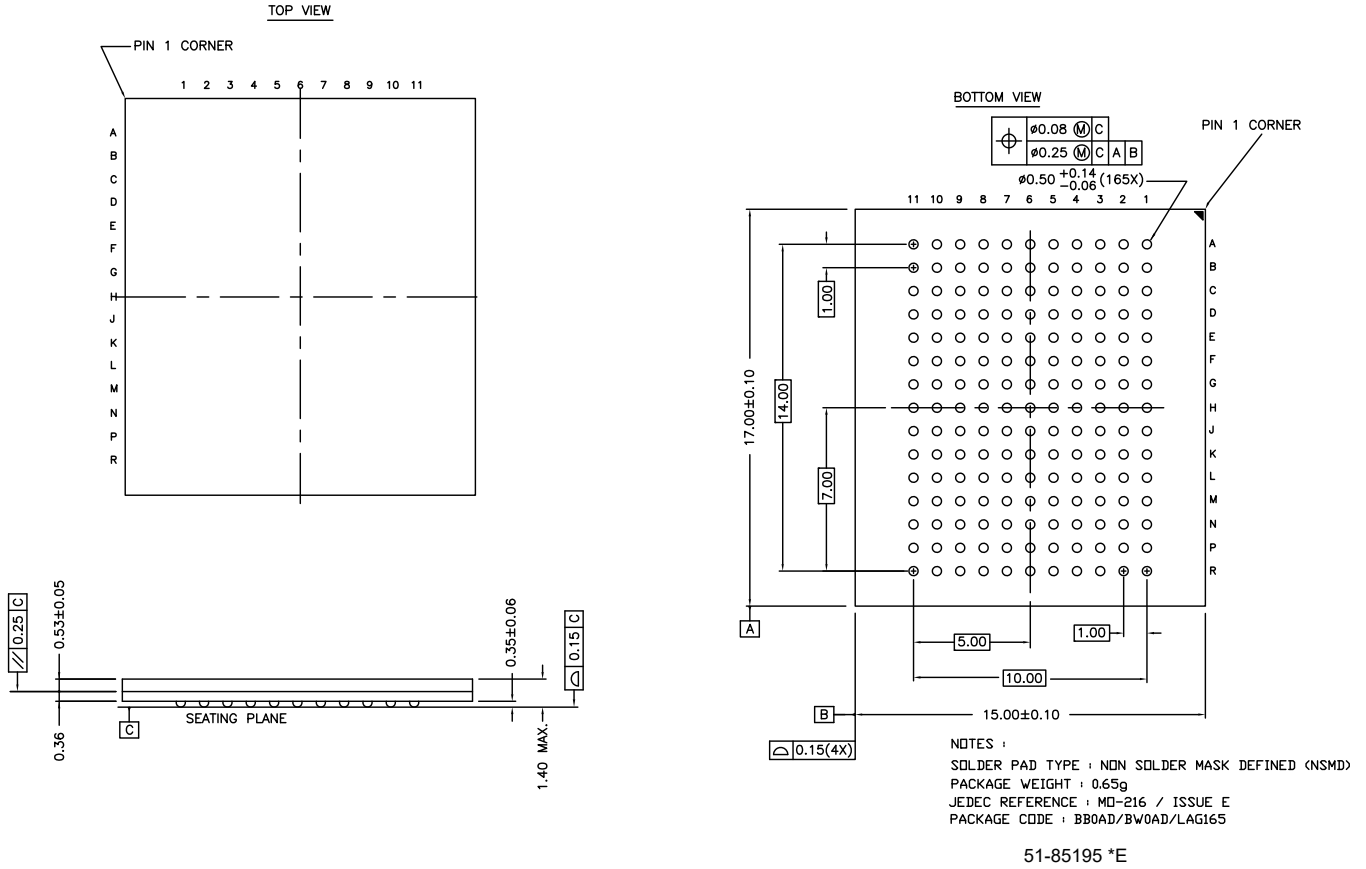



## Acronyms

**Table 2. Acronyms Used in this Document**

| Acronym | Description                             |
|---------|---|
| CEN     | Clock Enable                            |
| CMOS    | Complementary Metal Oxide Semiconductor |
| FBGA    | Fine-Pitch Ball Grid Array              |
| I/O     | Input/Output                            |
| JTAG    | Joint Test Action Group                 |
| NoBL    | No Bus Latency                          |
| OE      | Output Enable                           |
| SRAM    | Static Random Access Memory             |
| TCK     | Test Clock                              |
| TDI     | Test Data-In                            |
| TDO     | Test Data-Out                           |
| TMS     | Test Mode Select                        |
| TQFP    | Thin Quad Flat Pack                     |
| WE      | Write Enable                            |

## Document Conventions

### Units of Measure

**Table 3. Units of Measure**

| Symbol | Unit of Measure |
|--------|-----------------|
| °C     | degree Celsius  |
| MHz    | megahertz       |
| μA     | microampere     |
| mA     | milliampere     |
| mm     | millimeter      |
| ms     | millisecond     |
| ns     | nanosecond      |
| %      | percent         |
| pF     | picofarad       |
| V      | volt            |
| W      | watt            |



## Document History Page

| Document Title: CY7C1460KV33/CY7C1460KVE33/CY7C1462KVE33, 36-Mbit (1M × 36/2M × 18) Pipelined SRAM with NoBL™ Architecture (With ECC)<br>Document Number: 001-66680 |         |                 |  |
|---|---------|-----------------|--|
| Revision  | ECN     | Submission Date | Description of Change  |
| *F  | 4682541 | 03/16/2015      | Changed status from Preliminary to Final.  |
| *G  | 4680529 | 04/10/2015      | Updated <a href="#">Electrical Characteristics</a> :<br>Updated details in "Max" column corresponding to I <sub>SB2</sub> and I <sub>SB3</sub> parameters.<br>Updated <a href="#">Package Diagrams</a> :<br>spec 51-85195 – Changed revision from *C to *D.<br>Post to external web. |
| *H  | 4747474 | 04/29/2015      | Updated <a href="#">Functional Overview</a> :<br>Updated <a href="#">ZZ Mode Electrical Characteristics</a> :<br>Changed maximum value of I <sub>DDZZ</sub> parameter from 89 mA to 75 mA.   |
| *I  | 5028596 | 11/26/2015      | Added Errata.  |
| *J  | 5210861 | 04/07/2016      | Removed Errata.<br>Updated to new template.<br>Completing Sunset Review.   |
| *K  | 5337537 | 07/05/2016      | Updated <a href="#">Neutron Soft Error Immunity</a> :<br>Updated values in "Typ" and "Max" columns corresponding to LSBU (Device without ECC) parameter.   |
| *L  | 6063618 | 02/08/2018      | Updated <a href="#">Package Diagrams</a> :<br>spec 51-85050 – Changed revision from *E to *G.<br>Updated to new template.  |
| *M  | 6868871 | 04/28/2020      | Updated <a href="#">Package Diagrams</a> :<br>spec 51-85195 – Changed revision from *D to *E.  |



## Sales, Solutions, and Legal Information

### Worldwide Sales and Design Support

Cypress maintains a worldwide network of offices, solution centers, manufacturer's representatives, and distributors. To find the office closest to you, visit us at [Cypress Locations](#).

#### Products

|                               |  |
|-------------------------------|--|
| Arm® Cortex® Microcontrollers | <a href="http://cypress.com/arm">cypress.com/arm</a>               |
| Automotive                    | <a href="http://cypress.com/automotive">cypress.com/automotive</a> |
| Clocks & Buffers              | <a href="http://cypress.com/clocks">cypress.com/clocks</a>         |
| Interface                     | <a href="http://cypress.com/interface">cypress.com/interface</a>   |
| Internet of Things            | <a href="http://cypress.com/iot">cypress.com/iot</a>               |
| Memory                        | <a href="http://cypress.com/memory">cypress.com/memory</a>         |
| Microcontrollers              | <a href="http://cypress.com/mcu">cypress.com/mcu</a>               |
| PSoC                          | <a href="http://cypress.com/psoc">cypress.com/psoc</a>             |
| Power Management ICs          | <a href="http://cypress.com/pmic">cypress.com/pmic</a>             |
| Touch Sensing                 | <a href="http://cypress.com/touch">cypress.com/touch</a>           |
| USB Controllers               | <a href="http://cypress.com/usb">cypress.com/usb</a>               |
| Wireless Connectivity         | <a href="http://cypress.com/wireless">cypress.com/wireless</a>     |

#### PSoC® Solutions

[PSoC 1](#) | [PSoC 3](#) | [PSoC 4](#) | [PSoC 5LP](#) | [PSoC 6 MCU](#)

#### Cypress Developer Community

[Community](#) | [Code Examples](#) | [Projects](#) | [Video](#) | [Blogs](#) | [Training](#) | [Components](#)

#### Technical Support

[cypress.com/support](http://cypress.com/support)

© Cypress Semiconductor Corporation, 2011-2020. This document is the property of Cypress Semiconductor Corporation and its subsidiaries ("Cypress"). This document, including any software or firmware included or referenced in this document ("Software"), is owned by Cypress under the intellectual property laws and treaties of the United States and other countries worldwide. Cypress reserves all rights under such laws and treaties and does not, except as specifically stated in this paragraph, grant any license under its patents, copyrights, trademarks, or other intellectual property rights. If the Software is not accompanied by a license agreement and you do not otherwise have a written agreement with Cypress governing the use of the Software, then Cypress hereby grants you a personal, non-exclusive, nontransferable license (without the right to sublicense) (1) under its copyright rights in the Software (a) for Software provided in source code form, to modify and reproduce the Software solely for use with Cypress hardware products, only internally within your organization, and (b) to distribute the Software in binary code form externally to end users (either directly or indirectly through resellers and distributors), solely for use on Cypress hardware product units, and (2) under those claims of Cypress's patents that are infringed by the Software (as provided by Cypress, unmodified) to make, use, distribute, and import the Software solely for use with Cypress hardware products. Any other use, reproduction, modification, translation, or compilation of the Software is prohibited.

TO THE EXTENT PERMITTED BY APPLICABLE LAW, CYPRESS MAKES NO WARRANTY OF ANY KIND, EXPRESS OR IMPLIED, WITH REGARD TO THIS DOCUMENT OR ANY SOFTWARE OR ACCOMPANYING HARDWARE, INCLUDING, BUT NOT LIMITED TO, THE IMPLIED WARRANTIES OF MERCHANTABILITY AND FITNESS FOR A PARTICULAR PURPOSE. No computing device can be absolutely secure. Therefore, despite security measures implemented in Cypress hardware or software products, Cypress shall have no liability arising out of any security breach, such as unauthorized access to or use of a Cypress product. CYPRESS DOES NOT REPRESENT, WARRANT, OR GUARANTEE THAT CYPRESS PRODUCTS, OR SYSTEMS CREATED USING CYPRESS PRODUCTS, WILL BE FREE FROM CORRUPTION, ATTACK, VIRUSES, INTERFERENCE, HACKING, DATA LOSS OR THEFT, OR OTHER SECURITY INTRUSION (collectively, "Security Breach"). Cypress disclaims any liability relating to any Security Breach, and you shall and hereby do release Cypress from any claim, damage, or other liability arising from any Security Breach. In addition, the products described in these materials may contain design defects or errors known as errata which may cause the product to deviate from published specifications. To the extent permitted by applicable law, Cypress reserves the right to make changes to this document without further notice. Cypress does not assume any liability arising out of the application or use of any product or circuit described in this document. Any information provided in this document, including any sample design information or programming code, is provided only for reference purposes. It is the responsibility of the user of this document to properly design, program, and test the functionality and safety of any application made of this information and any resulting product. "High-Risk Device" means any device or system whose failure could cause personal injury, death, or property damage. Examples of High-Risk Devices are weapons, nuclear installations, surgical implants, and other medical devices. "Critical Component" means any component of a High-Risk Device whose failure to perform can be reasonably expected to cause, directly or indirectly, the failure of the High-Risk Device, or to affect its safety or effectiveness. Cypress is not liable, in whole or in part, and you shall and hereby do release Cypress from any claim, damage, or other liability arising from any use of a Cypress product as a Critical Component in a High-Risk Device. You shall indemnify and hold Cypress, its directors, officers, employees, agents, affiliates, distributors, and assigns harmless from and against all claims, costs, damages, and expenses, arising out of any claim, including claims for product liability, personal injury or death, or property damage arising from any use of a Cypress product as a Critical Component in a High-Risk Device. Cypress products are not intended or authorized for use as a Critical Component in any High-Risk Device except to the limited extent that (i) Cypress's published data sheet for the product explicitly states Cypress has qualified the product for use in a specific High-Risk Device, or (ii) Cypress has given you advance written authorization to use the product as a Critical Component in the specific High-Risk Device and you have signed a separate indemnification agreement.

Cypress, the Cypress logo, Spansion, the Spansion logo, and combinations thereof, WICED, PSoC, CapSense, EZ-USB, F-RAM, and Traveo are trademarks or registered trademarks of Cypress in the United States and other countries. For a more complete list of Cypress trademarks, visit [cypress.com](http://cypress.com). Other names and brands may be claimed as property of their respective owners.

## OUR CERTIFICATE

DiGi provide top-quality products and perfect service for customer worldwide through standardization, technological innovation and continuous improvement. DiGi through third-party certification, we stricly control the quality of products and services. Welcome your RFQ to

Email: [Info@DiGi-Electronics.com](mailto:Info@DiGi-Electronics.com)



Tel: +00 852-30501935

RFQ Email: [Info@DiGi-Electronics.com](mailto:Info@DiGi-Electronics.com)

DiGi is a global authorized distributor of electronic components.