

# CY8C4125PVS-482 Datasheet

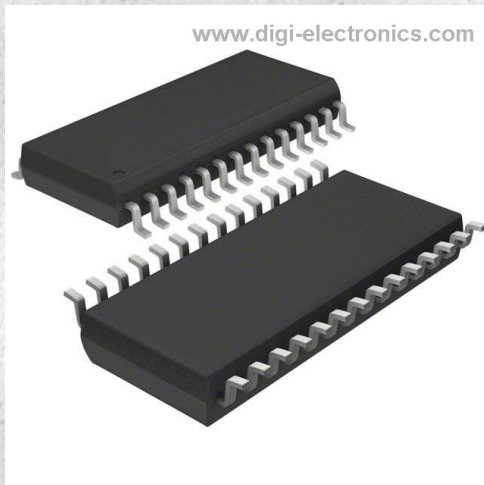

<https://www.DiGi-Electronics.com>

DiGi Electronics Part Number	CY8C4125PVS-482-DG
Manufacturer	<a href="#">Infineon Technologies</a>
Manufacturer Product Number	CY8C4125PVS-482
Description	IC MCU 32BIT 32KB FLASH 28SSOP
Detailed Description	ARM® Cortex®-M0 Automotive, AEC-Q100, PSOC® 4 C Y8C4100 Microcontroller IC 32-Bit Single-Core 24MHz 32KB (32K x 8) FLASH 28-SSOP

This model CY8C4125PVS-482 is available at DiGi.Electronics.

DiGi Electronics offers a global database of semiconductor and electronic component datasheets.

We welcome your inquiries regarding pricing, lead time, or other product-related questions.

 [Request a Quote](#)

 [Datasheet Search](#)



Tel: +00 852-30501935

RFQ Email: [Info@DiGi-Electronics.com](mailto:Info@DiGi-Electronics.com)

DiGi is a global authorized distributor of electronic components.

## Purchase and inquiry

**Manufacturer Product Number:**

CY8C4125PVS-482

**Series:**

Automotive, AEC-Q100, PSOC® 4 CY8C4100

**DiGi-Electronics Programmable:**

Not Verified

**Core Size:**

32-Bit Single-Core

**Connectivity:**

I2C, IrDA, LINbus, Microwire, SmartCard, SPI, SSP, UART/USART

**Number of I/O:**

24

**Program Memory Type:**

FLASH

**RAM Size:**

4K x 8

**Data Converters:**

A/D 8x12b SAR; D/A 2xDAC

**Operating Temperature:**

-40°C ~ 105°C (TA)

**Package / Case:**

28-SSOP (0.209", 5.30mm Width)

**Base Product Number:**

CY8C4125

**Manufacturer:**

Infineon Technologies

**Product Status:**

Obsolete

**Core Processor:**

ARM® Cortex®-M0

**Speed:**

24MHz

**Peripherals:**

Brown-out Detect/Reset, CapSense, LCD, LVD, POR, PWM, WDT

**Program Memory Size:**

32KB (32K x 8)

**EEPROM Size:**

-

**Voltage - Supply (Vcc/Vdd):**

1.71V ~ 5.5V

**Oscillator Type:**

Internal

**Mounting Type:**

Surface Mount

**Supplier Device Package:**

28-SSOP

## Environmental & Export classification

**RoHS Status:**

ROHS3 Compliant

**REACH Status:**

REACH Unaffected

**HTSUS:**

8542.31.0001

**Moisture Sensitivity Level (MSL):**

3 (168 Hours)

**ECCN:**

EAR99

## Features

- 32-bit MCU sub-system
- Low power 1.71 V to 5.5 V operation
- Capacitive sensing
- Serial communication
- Timing and pulse-width modulation
- Up to 24 programmable GPIOs

## Product validation

Qualified for automotive applications with higher temperature requirements. Product validation according to AEC-Q100.

## Description

PSoC™ 4100 devices include extensive support for programming, testing, debugging, and tracing both hardware and firmware. The Arm® Serial\_Wire Debug (SWD) interface supports all programming and debug features of the device.

Complete debug-on-chip functionality enables full device debugging in the final system using the standard production device. It does not require special interfaces, debugging pods, simulators, or emulators. Only the standard programming connections are required to fully support debug.

The PSoC Creator Integrated Development Environment (IDE) provides fully integrated programming and debug support for PSoC™ 4100 devices. The SWD interface is fully compatible with industry standard third party tools. With the ability to disable debug features, with very robust flash protection, and by allowing customer-proprietary functionality to be implemented in on-chip programmable blocks, the PSoC™ 4100 family provides a level of security not possible with multi-chip application solutions or with microcontrollers.

The debug circuits are enabled by default and can only be disabled in firmware. If not enabled, the only way to re-enable them is to erase the entire device, clear flash protection, and reprogram the device with new firmware that enables debugging.

Additionally, all device interfaces can be permanently disabled (device security) for applications concerned about phishing attacks due to a maliciously reprogrammed device or attempts to defeat security by starting and interrupting flash programming sequences. Because all programming, debug, and test interfaces are disabled when maximum device security is enabled, PSoC™ 4100 with device security enabled may not be returned for failure analysis. This is a trade-off the PSoC™ 4100 allows the customer to make.

# PSoC™ 4: PSoC™ 4100

## Table of contents

## Table of contents

	<b>Features</b> .....	1
	<b>Product validation</b> .....	1
	<b>Description</b> .....	1
	<b>Table of contents</b> .....	2
<b>1</b>	<b>Detailed features</b> .....	4
<b>2</b>	<b>Block diagram</b> .....	5
<b>3</b>	<b>Functional overview</b> .....	6
3.1	CPU and memory subsystem .....	6
3.1.1	CPU .....	6
3.1.2	Flash .....	6
3.1.3	SRAM .....	6
3.1.4	SROM .....	6
3.2	System resources .....	6
3.2.1	Power system .....	6
3.2.2	Clock system .....	7
3.2.3	IMO clock source .....	7
3.2.4	ILO clock source .....	7
3.2.5	Watchdog timer .....	8
3.2.6	Reset .....	8
3.2.7	Voltage reference .....	8
3.3	Analog blocks .....	8
3.3.1	12-bit SAR ADC .....	8
3.3.2	Opamp (CTBm block) .....	9
3.3.3	Temperature sensor .....	9
3.3.4	Low-power comparators .....	9
3.4	Fixed function digital .....	9
3.4.1	Timer/Counter/PWM block .....	9
3.4.2	Serial communication blocks (SCB) .....	10
3.5	GPIO .....	10
3.6	Special function peripherals .....	11
3.6.1	LCD segment drive .....	11
3.6.2	CAPSENSE™ .....	11
<b>4</b>	<b>Pinouts</b> .....	12
<b>5</b>	<b>Power</b> .....	15
5.1	Unregulated external supply .....	15
5.2	Regulated external supply .....	16
<b>6</b>	<b>Development support</b> .....	17

# PSoC™ 4: PSoC™ 4100

## Table of contents

6.1	Documentation .....	17
6.2	Online .....	17
6.3	Tools .....	17
<b>7</b>	<b>Electrical specifications</b> .....	<b>18</b>
7.1	Absolute maximum ratings .....	18
7.2	Device-level specifications .....	19
7.2.1	GPIO .....	21
7.2.2	XRES .....	24
7.3	Analog peripherals .....	25
7.3.1	Opamp .....	25
7.3.2	Comparator .....	28
7.3.3	Temperature sensor .....	31
7.3.4	SAR ADC .....	31
7.3.5	CSD .....	34
7.4	Digital peripherals .....	35
7.4.1	Timer/Counter/PWM .....	35
7.4.2	I2C .....	37
7.4.3	LCD direct drive .....	37
7.4.4	SPI specifications .....	39
7.5	Memory .....	40
7.6	System resources .....	42
7.6.1	Power-on-Reset (POR) with Brown Out .....	42
7.6.2	Voltage monitors .....	43
7.6.3	SWD interface .....	44
7.6.4	Internal main oscillator .....	45
7.6.5	Internal low-speed oscillator .....	46
<b>8</b>	<b>Ordering information</b> .....	<b>48</b>
8.1	Part numbering conventions .....	48
<b>9</b>	<b>Packaging</b> .....	<b>50</b>
<b>10</b>	<b>Acronyms</b> .....	<b>52</b>
<b>11</b>	<b>Document conventions</b> .....	<b>56</b>
<b>12</b>	<b>References</b> .....	<b>58</b>
	<b>Revision history</b> .....	<b>59</b>
	<b>Disclaimer</b> .....	<b>62</b>

## PSoC™ 4: PSoC™ 4100

### 1 Detailed features

## 1 Detailed features

### 32-bit MCU sub-system

- Automotive Electronics Council (AEC) AEC-Q100 qualified
- 24 MHz Arm® Cortex®-M0 CPU with single-cycle multiply
- Up to 32 kB of flash with Read Accelerator
- Up to 4 kB of SRAM

### Programmable analog

- One opamp with reconfigurable high-drive external and high-bandwidth internal drive, Comparator mode, and ADC input buffering capability
- 12-bit, 806 Ksps SAR ADC with differential and single-ended modes and Channel Sequencer with signal averaging
- Two current DACs (IDACs) for general-purpose or capacitive sensing applications on any pin
- Two low-power comparators that operate in Deep Sleep

### Low power 1.71 V to 5.5 V operation

- 20 nA Stop Mode with GPIO pin wakeup
- Hibernate and Deep Sleep modes allow wakeup-time versus power trade-offs

### Capacitive sensing

- Infineon Capacitive Sigma-Delta (CSD) provides best-in-class SNR (>5:1) and water tolerance
- Infineon supplied software component makes capacitive sensing design easy
- Automatic hardware tuning (SmartSense)

### Segment LCD drive

- LCD drive supported on all pins (common or segment)
- Operates in Deep Sleep mode with 4 bits per pin memory

### Serial communication

- Two independent run-time reconfigurable serial communication blocks (SCBs) with reconfigurable I2C, SPI, UART, or LIN Slave 1.3, 2.1/2.2 functionality

### Timing and Pulse-Width modulation

- Four 16-bit Timer/Counter Pulse-Width Modulator (TCPWM) blocks
- Center-aligned, Edge, and Pseudo-random modes
- Comparator-based triggering of Kill signals for motor drive and other high reliability digital logic applications

### Up to 24 programmable GPIOs

- 28-pin SSOP package
- Any GPIO pin can be CAPSENSE™, LCD, analog, or digital
- Drive modes, strengths, and slew rates are programmable

### Temperature ranges

- A Grade: -40 °C to +85 °C
- S Grade: -40 °C to +105 °C

### PSoC Creator design environment

- Integrated Development Environment provides schematic design entry and build (with analog and digital automatic routing)
- Applications Programming Interface (API component) for all fixed-function and programmable peripherals

### Industry standard tool compatibility

- After schematic entry, development can be done with Arm®-based industry-standard development tools

# PSoC™ 4: PSoC™ 4100

## 2 Block diagram

## 2 Block diagram

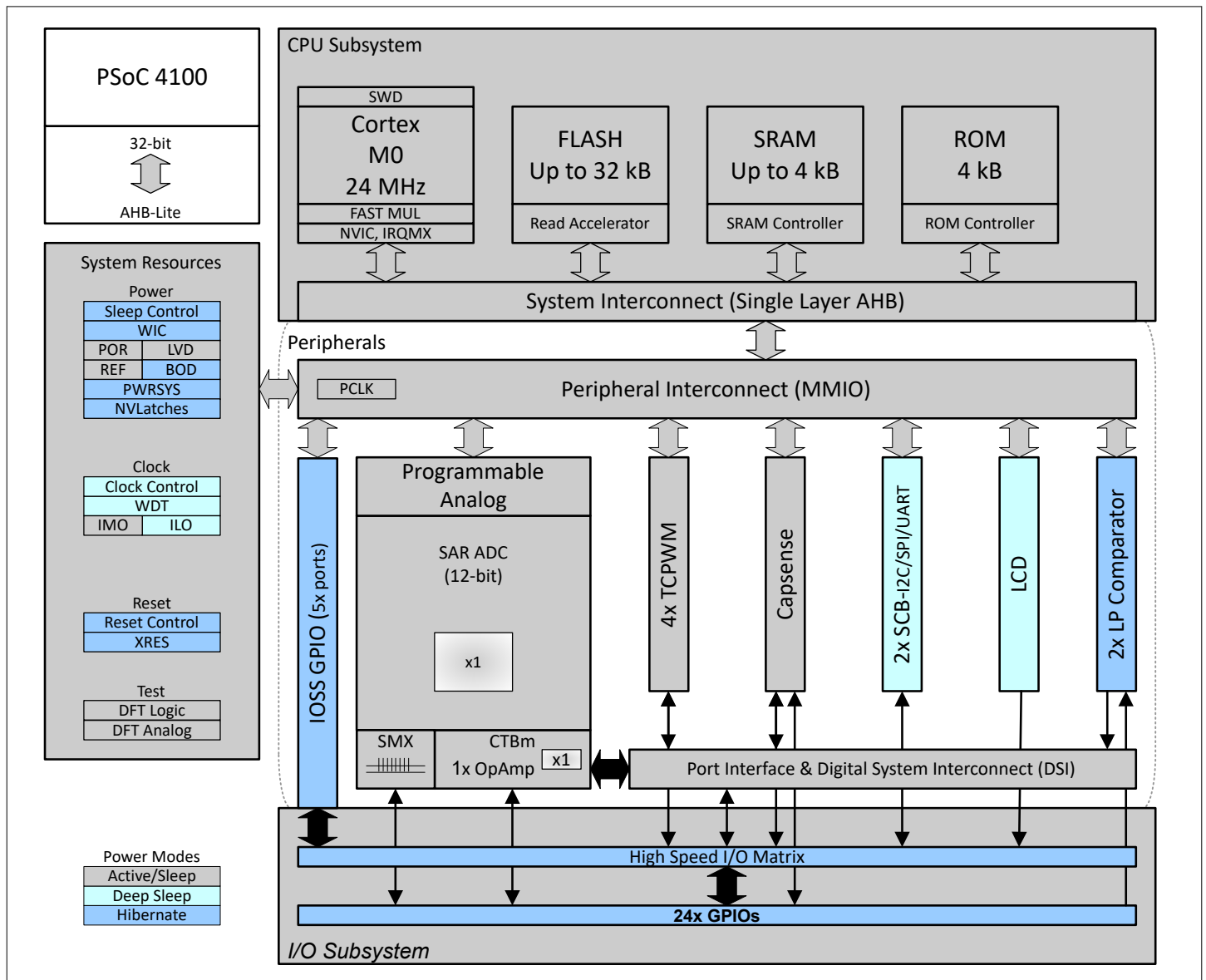

Figure 1 Block diagram

## PSoC™ 4: PSoC™ 4100

### 3 Functional overview

## 3 Functional overview

### 3.1 CPU and memory subsystem

#### 3.1.1 CPU

The Cortex-M0 CPU in PSoC™ 4100 is part of the 32-bit MCU subsystem, which is optimized for low power operation with extensive clock gating. It mostly uses 16-bit instructions and executes a subset of the Thumb-2 instruction set. This enables fully compatible binary upward migration of the code to higher performance processors such as the Cortex®-M3 and M4, thus enabling upward compatibility. The Infineon implementation includes a hardware multiplier that provides a 32-bit result in one cycle. It includes a nested vectored interrupt controller (NVIC) block with 32 interrupt inputs and also includes a Wakeup Interrupt Controller (WIC), which can wake the processor up from Deep Sleep mode allowing power to be switched off to the main processor when the chip is in Deep Sleep mode. The Cortex®-M0 CPU provides a Non-Maskable Interrupt input (NMI), which is made available to the user when it is not in use for system functions requested by the user.

The CPU also includes a debug interface, the Serial Wire Debug (SWD) interface, which is a 2-wire form of JTAG; the debug configuration used for PSoC™ 4100 has four break-point (address) comparators and two watchpoint (data) comparators.

#### 3.1.2 Flash

PSoC™ 4100 has a flash module with a flash accelerator tightly coupled to the CPU to improve average access times from the flash block. The flash block is designed to deliver 0 wait-state (WS) access time at 24 MHz. Part of the flash module can be used to emulate EEPROM operation if required.

The PSoC™ 4100 flash supports the following flash protection modes at the memory sub-system level.

**Open:** No protection. Factory default mode that the product is shipped in.

**Protected:** User may change from Open to Protected. This mode disables debug interface accesses. The mode can be set back to Open but only after completely erasing the flash.

**Kill:** User may change from Open to Kill. This mode disables all debug accesses. The part cannot be erased externally, thus obviating the possibility of partial erasure by power interruption and potential malfunction and security leaks. This is an irrevocable mode.

In addition, row-level Read/Write protection is also supported to prevent inadvertent Writes as well as selectively block Reads. Flash Read/Write/Erase operations are always available for internal code using system calls.

#### 3.1.3 SRAM

SRAM memory is retained during Hibernate.

#### 3.1.4 SROM

A supervisory ROM that contains boot and configuration routines is provided.

## 3.2 System resources

### 3.2.1 Power system

The power system is described in detail in the section [Power](#). It provides assurance that voltage levels are as required for each respective mode and either delay mode entry (on power-on reset (POR), for example) until voltage levels are as required for proper function or generate resets (brown-out detect (BOD)) or interrupts (low-voltage detect (LVD)). The PSoC™ 4100 operates with a single external supply over the range of 1.71 V to 5.5 V and has five different power

## PSoC™ 4: PSoC™ 4100

### 3 Functional overview

modes, transitions between which are managed by the power system. The PSoC™ 4100 provides Sleep, Deep Sleep, Hibernate, and Stop low-power modes.

### 3.2.2 Clock system

The PSoC™ 4100 clock system is responsible for providing clocks to all subsystems that require clocks and for switching between different clock sources without glitching. In addition, the clock system ensures that no metastable conditions occur.

The clock system for the PSoC™ 4100 consists of two internal oscillators, IMO and the ILO, and provision for an external clock.

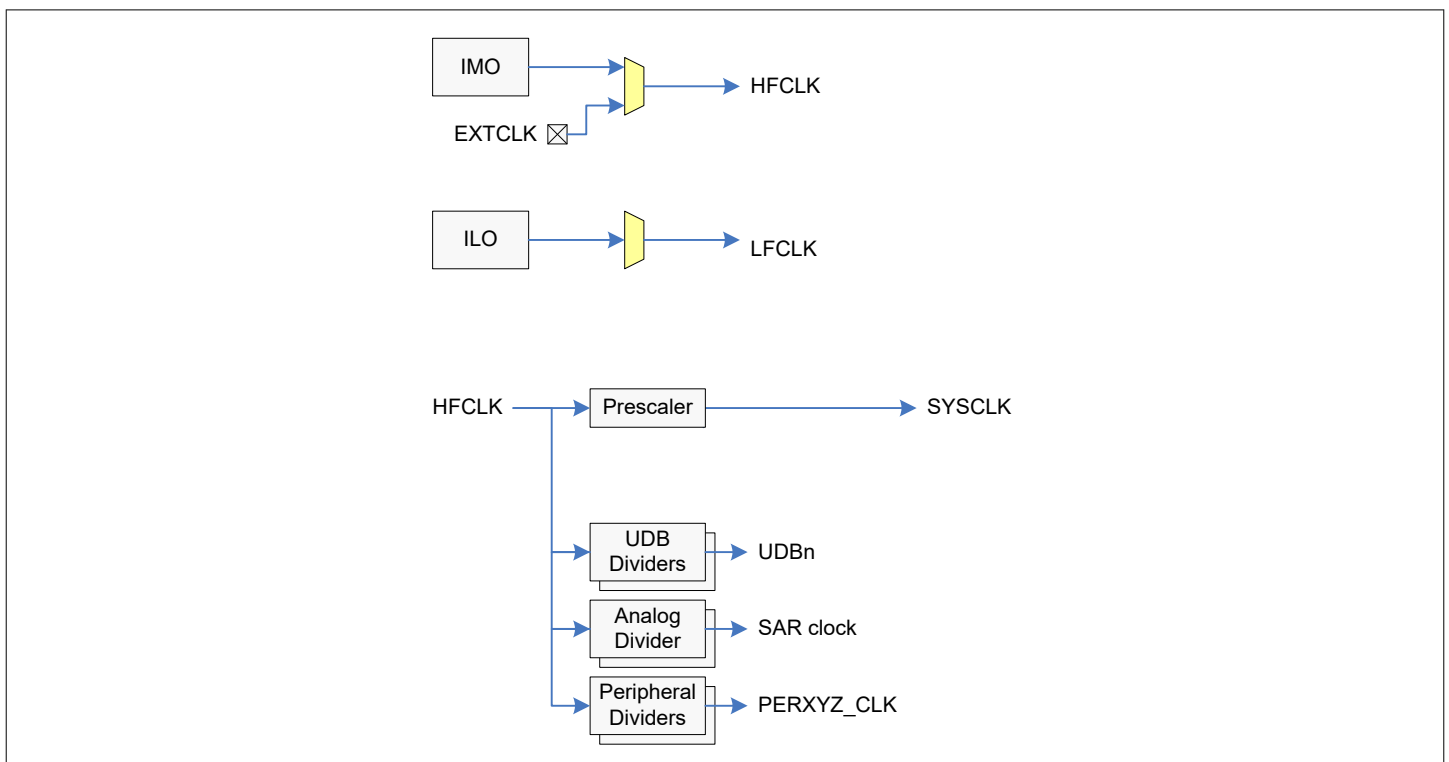

**Figure 2** PSoC™ 4100 MCU clocking architecture

The HFCLK signal can be divided down (see Figure 2) to generate synchronous clocks for the analog and digital peripherals. There are a total of 12 clock dividers for the PSoC™ 4100, each with 16-bit divide capability. The analog clock leads the digital clocks to allow analog events to occur before digital clock-related noise is generated. The 16-bit capability allows a lot of flexibility in generating fine-grained frequency values and is fully supported in PSoC Creator.

### 3.2.3 IMO clock source

The IMO is the primary source of internal clocking in the PSoC™ 4100. It is trimmed during testing to achieve the specified accuracy. Trim values are stored in nonvolatile latches (NVL). Additional trim settings from flash can be used to compensate for changes. The IMO default frequency is 24 MHz and it can be adjusted between 3 MHz to 24 MHz in steps of 1 MHz. IMO tolerance with Infineon-provided calibration settings is  $\pm 2\%$ .

### 3.2.4 ILO clock source

The ILO is a very low power oscillator, which is primarily used to generate clocks for peripheral operation in Deep Sleep mode. ILO-driven counters can be calibrated to the IMO to improve accuracy. Infineon provides a software component, which does the calibration.

## PSoC™ 4: PSoC™ 4100

### 3 Functional overview

#### 3.2.5 Watchdog timer

A watchdog timer is implemented in the clock block running from the ILO; this allows watchdog operation during Deep Sleep and generates a watchdog reset if not serviced before the timeout occurs. The watchdog reset is recorded in the Reset Cause register.

#### 3.2.6 Reset

PSoC™ 4100 can be reset from a variety of sources including a software reset. Reset events are asynchronous and guarantee reversion to a known state. The reset cause is recorded in a register, which is sticky through reset and allows software to determine the cause of the Reset. An XRES pin is reserved for external reset to avoid complications with configuration and multiple pin functions during power-on or reconfiguration. The XRES pin has an internal pull-up resistor that is always enabled.

#### 3.2.7 Voltage reference

The PSoC™ 4100 reference system generates all internally required references. A 1% voltage reference spec is provided for the 12-bit ADC. To allow better signal-to-noise ratios (SNR) and better absolute accuracy, it is possible to bypass the internal reference using a GPIO pin or to use an external reference for the SAR.

### 3.3 Analog blocks

#### 3.3.1 12-bit SAR ADC

The 12-bit 806 Ksps SAR ADC can operate at a maximum clock rate of 14.5 MHz and requires a minimum of 18 clocks at that frequency to do a 12-bit conversion.

The block functionality is augmented for the user by adding a reference buffer to it (trimmable to  $\pm 1\%$ ) and by providing the choice (for the PSoC™ 4100 case) of three internal voltage references:  $V_{DD}$ ,  $V_{DD}/2$ , and  $V_{REF}$  (nominally 1.024 V) as well as an external reference through a GPIO pin. The Sample-and-Hold (S/H) aperture is programmable allowing the gain bandwidth requirements of the amplifier driving the SAR inputs, which determine its settling time, to be relaxed if required. System performance will be 65 dB for true 12-bit precision providing appropriate references are used and system noise levels permit. To improve performance in noisy conditions, it is possible to provide an external bypass (through a fixed pin location) for the internal reference amplifier.

The SAR is connected to a fixed set of pins through an 8-input sequencer. The sequencer cycles through selected channels autonomously (sequencer scan) and does so with zero switching overhead (that is, aggregate sampling bandwidth is equal to 806 Ksps whether it is for a single channel or distributed over several channels). The sequencer switching is effected through a state machine or through firmware-driven switching. A feature provided by the sequencer is buffering of each channel to reduce CPU interrupt service requirements. To accommodate signals with varying source impedance and frequency, it is possible to have different sample times programmable for each channel. Also, signal range specification through a pair of range registers (low and high range values) is implemented with a corresponding out-of-range interrupt if the digitized value exceeds the programmed range; this allows fast detection of out-of-range values without the necessity of having to wait for a sequencer scan to be completed and the CPU to read the values and check for out-of-range values in software.

The SAR is able to digitize the output of the on-board temperature sensor for calibration and other temperature-dependent functions. The SAR is not available in Deep Sleep and Hibernate modes as it requires a high-speed clock (up to 18 MHz). The SAR operating range is 1.71 V to 5.5 V.

## PSoC™ 4: PSoC™ 4100

### 3 Functional overview

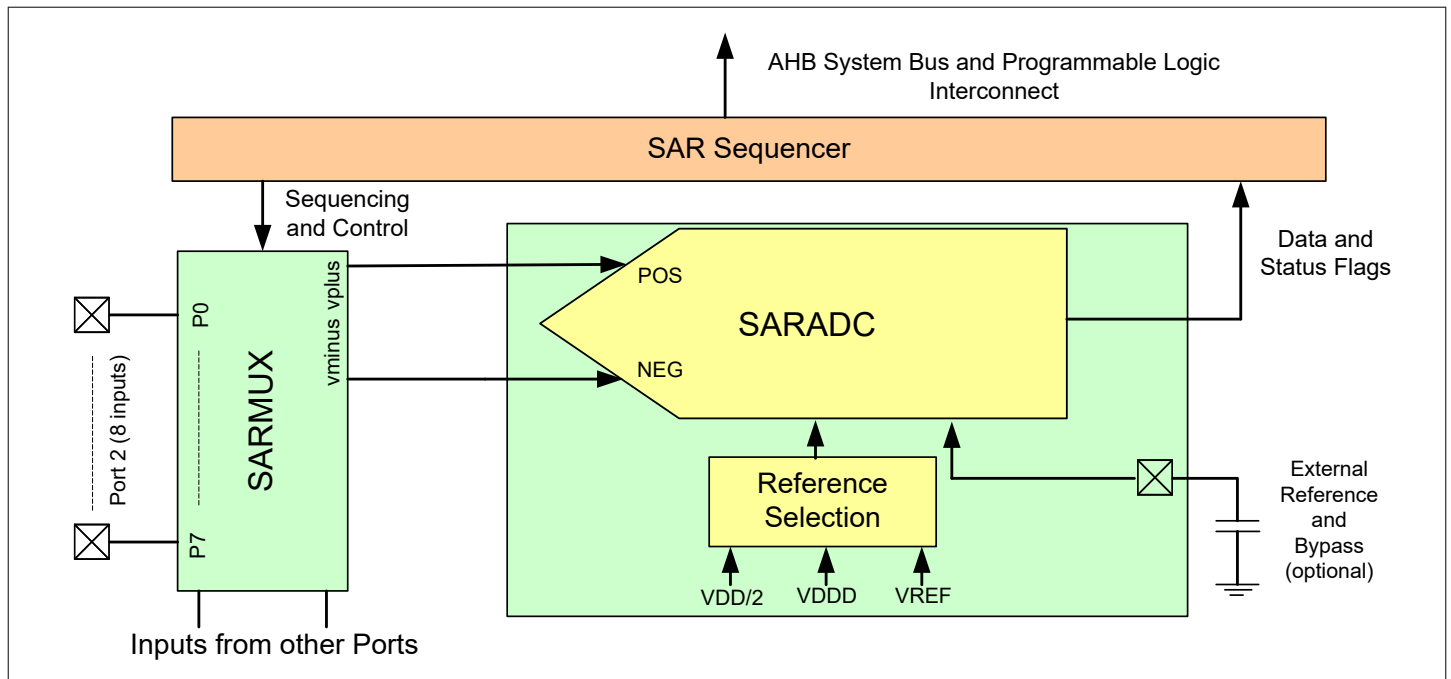

**Figure 3 SAR ADC system diagram**

### 3.3.2 Opamp (CTBm block)

PSoC™ 4100 has an opamp with Comparator mode, which allows most common analog functions to be performed on-chip eliminating external components; PGAs, voltage buffers, filters, trans-impedance amplifiers, and other functions can be realized with external passives saving power, cost, and space. The on-chip opamp is designed with enough bandwidth to drive the S/H circuit of the ADC without requiring external buffering.

### 3.3.3 Temperature sensor

PSoC™ 4100 has one on-chip temperature sensor. This consists of a diode, which is biased by a current source that can be disabled to save power. The temperature sensor is connected to the ADC, which digitizes the reading and produces a temperature value using Infineon supplied software that includes calibration and linearization.

### 3.3.4 Low-power comparators

PSoC™ 4100 has a pair of low-power comparators, which can also operate in the Deep Sleep and Hibernate modes. This allows the analog system blocks to be disabled while retaining the ability to monitor external voltage levels during low-power modes. The comparator outputs are normally synchronized to avoid metastability unless operating in an asynchronous power mode (Hibernate) where the system wake-up circuit is activated by a comparator switch event.

## 3.4 Fixed function digital

### 3.4.1 Timer/Counter/PWM block

The Timer/Counter/PWM block consists of four 16-bit counters with user-programmable period length. There is a Capture register to record the count value at the time of an event (which may be an I/O event), a period register which is used to either stop or auto-reload the counter when its count is equal to the period register, and compare registers to generate compare value signals which are used as PWM duty cycle outputs. The block also provides true and complementary outputs with programmable offset between them to allow use as deadband programmable

## PSoC™ 4: PSoC™ 4100

### 3 Functional overview

complementary PWM outputs. It also has a Kill input to force outputs to a predetermined state; for example, this is used in motor drive systems when an overcurrent state is indicated and the PWMs driving the FETs need to be shut off immediately with no time for software intervention.

#### 3.4.2 Serial communication blocks (SCB)

PSoC™ 4100 has two SCBs, which can each implement an I<sup>2</sup>C, UART, SPI, or LIN Slave interface.

**I<sup>2</sup>C Mode:** The hardware I<sup>2</sup>C block implements a full multi-master and slave interface (it is capable of multimaster arbitration). This block is capable of operating at speeds of up to 1 Mbps (Fast Mode Plus) and has flexible buffering options to reduce interrupt overhead and latency for the CPU. The FIFO mode is available in all channels and is very useful in the absence of DMA.

The I<sup>2</sup>C peripheral is compatible with the I<sup>2</sup>C Standard-mode, Fast-mode, and Fast-mode Plus devices as defined in the NXP I<sup>2</sup>C-bus specification and user manual (UM10204). The I<sup>2</sup>C bus I/O is implemented with GPIO in open-drain modes. The I<sup>2</sup>C bus uses open-drain drivers for clock and data with pull-up resistors on the bus for clock and data connected to all nodes. Required Rise and Fall times for different I<sup>2</sup>C speeds are guaranteed by using appropriate pull-up resistor values depending on V<sub>DD</sub>, Bus Capacitance, and resistor tolerance. For detailed information on how to calculate the optimum pull-up resistor value for your design, please refer to the UM10204 I<sup>2</sup>C bus specification and user manual, the newest revision is available at [www.nxp.com](http://www.nxp.com).

The PSoC™ 4100 is not completely compliant with the I<sup>2</sup>C spec in the following respects:

- GPIO cells are not overvoltage tolerant and, therefore, cannot be hot-swapped or powered up independently of the rest of the I<sup>2</sup>C system.
- Fast-mode Plus has an I<sub>OL</sub> specification of 20 mA at a V<sub>OL</sub> of 0.4 V. The GPIO cells can sink a maximum of 8 mA I<sub>OL</sub> with a V<sub>OL</sub> maximum of 0.6 V.
- Fast-mode and Fast-mode Plus specify minimum Fall times, which are not met with the GPIO cell; Slow strong mode can help meet this spec depending on the Bus Load.
- When the SCB is an I<sup>2</sup>C Master, it interposes an IDLE state between NACK and Repeated Start; the I<sup>2</sup>C spec defines Bus free as following a Stop condition so other Active Masters do not intervene but a Master that has just become activated may start an Arbitration cycle.
- When the SCB is in I<sup>2</sup>C Slave mode, and Address Match on External Clock is enabled (EC\_AM = 1) along with operation in the internally clocked mode (EC\_OP = 0), then its I<sup>2</sup>C address must be even.

**UART Mode:** This is a full-feature UART operating at up to 1 Mbps. It supports automotive single-wire interface (LIN), infrared interface (IrDA), and SmartCard (ISO7816) protocols, all of which are minor variants of the basic UART protocol. In addition, it supports the 9-bit multiprocessor mode that allows addressing of peripherals connected over common RX and TX lines. Common UART functions such as parity error, break detect, and frame error are supported. An 8-deep FIFO allows much greater CPU service latencies to be tolerated.

**SPI Mode:** The SPI mode supports full Motorola SPI, TI SSP (essentially adds a start pulse used to synchronize SPI Codecs), and National Microwire (half-duplex form of SPI). The SPI block can use the FIFO and also supports an EzSPI mode in which data interchange is reduced to reading and writing an array in memory.

**LIN Slave Mode:** The LIN Slave mode uses the SCB hardware block and implements a full LIN slave interface. This LIN slave is compliant with LIN v1.3 and LIN v2.1/2.2 specification standards. It is certified by C&S GmbH based on the standard protocol and data link layer conformance tests. The LIN slave can be operated at baud rates of up to ~20 Kbps with a maximum of 40-meter cable length. PSoC Creator software supports up to two LIN slave interfaces in the PSoC™ 4 device, providing built-in application programming interfaces (APIs) based on the LIN specification standard.

### 3.5 GPIO

PSoC™ 4100 has 24 GPIOs. The GPIO block implements the following:

- Eight drive strength modes:
  - Analog input mode (input and output buffers disabled)

## PSoC™ 4: PSoC™ 4100

### 3 Functional overview

- Input only
- Weak pull-up with strong pull-down
- Strong pull-up with weak pull-down
- Open drain with strong pull-down
- Open drain with strong pull-up
- Strong pull-up with strong pull-down
- Weak pull-up with weak pull-down
- Input threshold select (CMOS or LVTTTL).
- Individual control of input and output buffer enabling/disabling in addition to the drive strength modes.
- Hold mode for latching previous state (used for retaining I/O state in Deep Sleep mode and Hibernate modes).
- Selectable slew rates for dV/dt related noise control to improve EMI.

The pins are organized in logical entities called ports, which are 8-bit in width. During power-on and reset, the blocks are forced to the disable state so as not to crowbar any inputs and/or cause excess turn-on current. A multiplexing network known as a high-speed I/O matrix is used to multiplex between various signals that may connect to an I/O pin. Pin locations for fixed-function peripherals are also fixed to reduce internal multiplexing complexity.

Data output and pin state registers store, respectively, the values to be driven on the pins and the states of the pins themselves.

Every I/O pin can generate an interrupt if so enabled and each I/O port has an interrupt request (IRQ) and interrupt service routine (ISR) vector associated with it (5 for PSoC™ 4100).

## 3.6 Special function peripherals

### 3.6.1 LCD segment drive

The PSoC™ 4100 has an LCD controller which can drive up to four commons and up to 32 segments. It uses full digital methods to drive the LCD segments requiring no generation of internal LCD voltages. The two methods used are referred to as digital correlation and PWM.

Digital correlation pertains to modulating the frequency and levels of the common and segment signals to generate the highest RMS voltage across a segment to light it up or to keep the RMS signal zero. This method is good for STN displays but may result in reduced contrast with TN (cheaper) displays.

PWM pertains to driving the panel with PWM signals to effectively use the capacitance of the panel to provide the integration of the modulated pulse-width to generate the desired LCD voltage. This method results in higher power consumption but can result in better results when driving TN displays. LCD operation is supported during Deep Sleep refreshing a small display buffer (4 bits; 1 32-bit register per port).

### 3.6.2 CAPSENSE™

CAPSENSE™ is supported on all pins in the PSoC™ 4100 through a Capacitive Sigma-Delta (CSD) block that can be connected to any pin through an analog mux bus that any GPIO pin can be connected to via an Analog switch. CAPSENSE™ function can thus be provided on any pin or group of pins in a system under software control. A component is provided for the CAPSENSE™ block to make it easy for the user.

Shield voltage can be driven on another Mux Bus to provide water tolerance capability. Water tolerance is provided by driving the shield electrode in phase with the sense electrode to keep the shield capacitance from attenuating the sensed input.

The CAPSENSE™ block has two IDACs which can be used for general purposes if CAPSENSE™ is not being used. (both IDACs are available in that case) or if CAPSENSE™ is used without water tolerance (one IDAC is available).

## PSoC™ 4: PSoC™ 4100

### 4 Pinouts

## 4 Pinouts

The following is the pin-list for PSoC™ 4100. Port 2 comprises of the high-speed Analog inputs for the SAR Mux. P1.7 is the optional external input and bypass for the SAR reference. Ports 3 and 4 contain the Digital Communication channels. All pins support CSD CAPSENSE™ and Analog Mux Bus connections.

Pin		28-SSOP		Alternate functions for pins					Pin description
Name	Type	Pin	Name	Analog	Alt 1	Alt 2	Alt 3	Alt 4	
VSSD	Power	DN	–	–	–	–	–	–	Digital Ground
P2.2	GPIO	5	P2.2	sarmux.2	–	–	–	–	Port 2 Pin 2: gpio, lcd, csd, sarmux
P2.3	GPIO	6	P2.3	sarmux.3	–	–	–	–	Port 2 Pin 3: gpio, lcd, csd, sarmux
P2.4	GPIO	7	P2.4	sarmux.4	tcpwm0_p[1]	–	–	–	Port 2 Pin 4: gpio, lcd, csd, sarmux, pwm
P2.5	GPIO	8	P2.5	sarmux.5	tcpwm0_n[1]	–	–	–	Port 2 Pin 5: gpio, lcd, csd, sarmux, pwm
P2.6	GPIO	9	P2.6	sarmux.6	tcpwm1_p[1]	–	–	–	Port 2 Pin 6: gpio, lcd, csd, sarmux, pwm
P2.7	GPIO	10	P2.7	sarmux.7	tcpwm1_n[1]	–	–	–	Port 2 Pin 7: gpio, lcd, csd, sarmux, pwm
P3.0	GPIO	11	P3.0	–	tcpwm0_p[0]	scb1_uart_rx[0]	scb1_i2c_scl[0]	scb1_spi_mosi[0]	Port 3 Pin 0: gpio, lcd, csd, pwm, scb1
P3.1	GPIO	12	P3.1	–	tcpwm0_n[0]	scb1_uart_tx[0]	scb1_i2c_sda[0]	scb1_spi_miso[0]	Port 3 Pin 1: gpio, lcd, csd, pwm, scb1
P3.2	GPIO	13	P3.2	–	tcpwm1_p[0]	–	swd_io	scb1_spi_clk[0]	Port 3 Pin 2: gpio, lcd, csd, pwm, scb1, swd
P3.3	GPIO	14	P3.3	–	tcpwm1_n[0]	–	swd_clk	scb1_spi_ssel_0[0]	Port 3 Pin 3: gpio, lcd, csd, pwm, scb1, swd
P4.0	GPIO	15	P4.0	–	–	scb0_uart_rx	scb0_i2c_scl	scb0_spi_mosi	Port 4 Pin 0: gpio, lcd, csd, scb0
P4.1	GPIO	16	P4.1	–	–	scb0_uart_tx	scb0_i2c_sda	scb0_spi_miso	Port 4 Pin 1: gpio, lcd, csd, scb0
P4.2	GPIO	17	P4.2	csd_c_mod	–	–	–	scb0_spi_clk	Port 4 Pin 2: gpio, lcd, csd, scb0
P4.3	GPIO	18	P4.3	csd_c_sh_tank	–	–	–	scb0_spi_ssel_0	Port 4 Pin 3: gpio, lcd, csd, scb0

## PSoC™ 4: PSoC™ 4100

### 4 Pinouts

Pin		28-SSOP		Alternate functions for pins					Pin description
Name	Type	Pin	Name	Analog	Alt 1	Alt 2	Alt 3	Alt 4	
P0.0	GPIO	19	P0.0	comp1_in_p	-	-	-	scb0_spi_ssel_1	Port 0 Pin 0: gpio, lcd, csd, scb0, comp
P0.1	GPIO	20	P0.1	comp1_in_n	-	-	-	scb0_spi_ssel_2	Port 0 Pin 1: gpio, lcd, csd, scb0, comp
P0.2	GPIO	21	P0.2	comp2_in_p	-	-	-	scb0_spi_ssel_3	Port 0 Pin 2: gpio, lcd, csd, scb0, comp
P0.3	GPIO	22	P0.3	comp2_in_n	-	-	-	-	Port 0 Pin 3: gpio, lcd, csd, comp
P0.6	GPIO	23	P0.6	-	ext_clk	-	-	scb1_spi_clk[1]	Port 0 Pin 6: gpio, lcd, csd, scb1, ext_clk
P0.7	GPIO	24	P0.7	-	-	-	wakeup	scb1_spi_ssel_0[1]	Port 0 Pin 7: gpio, lcd, csd, scb1, wakeup
XRES	XRES	25	XRES	-	-	-	-	-	Chip reset, active low
VCCD	Power	26	VCCD	-	-	-	-	-	Regulated supply, connect to 1 µF cap or 1.8 V
VDDD	Power	27	VDDD	-	-	-	-	-	Common power supply (Analog & Digital) 1.8 V–5.5 V
VSSA	Power	28(DN)	VSS	-	-	-	-	-	Analog Ground
P1.0	GPIO	1	P1.0	ctb.oa0_in_p	tcpwm2_p[1]	-	-	-	Port 1 Pin 0: gpio, lcd, csd, ctb, pwm
P1.1	GPIO	2	P1.1	ctb.oa0_in_m	tcpwm2_n[1]	-	-	-	Port 1 Pin 1: gpio, lcd, csd, ctb, pwm
P1.2	GPIO	3	P1.2	ctb.oa0_out	tcpwm3_p[1]	-	-	-	Port 1 Pin 2: gpio, lcd, csd, ctb, pwm
P1.7	GPIO	4	P1.7	ctb.oa1_in_p_alt ext_vref	-	-	-	-	Port 1 Pin 7: gpio, lcd, csd, ext_ref

Notes:

## PSoC™ 4: PSoC™ 4100

### 4 Pinouts

1. *tcpwm\_p* and *tcpwm\_n* refer to *tcpwm* non-inverted and inverted outputs respectively.
2. *P3.2* and *P3.3* are SWD pins after boot (reset).

#### Descriptions of the pin functions are as follows:

**VDDD:** Power supply for both analog and digital sections (where there is no  $V_{DDA}$  pin).

**VDDA:** Analog  $V_{DD}$  pin where package pins allow; shorted to  $V_{DDD}$  otherwise.

**VSSA:** Analog ground pin where package pins allow; shorted to VSS otherwise

**VSS:** Ground pin.

**VCCD:** Regulated Digital supply ( $1.8\text{ V} \pm 5\%$ ).

Port Pins can all be used as LCD Commons, LCD Segment drivers, or CSD sense and shield pins can be connected to AMUXBUS A or B or can all be used as GPIO pins that can be driven by firmware or DSI signals.

The following package is supported: 28-pin SSOP.

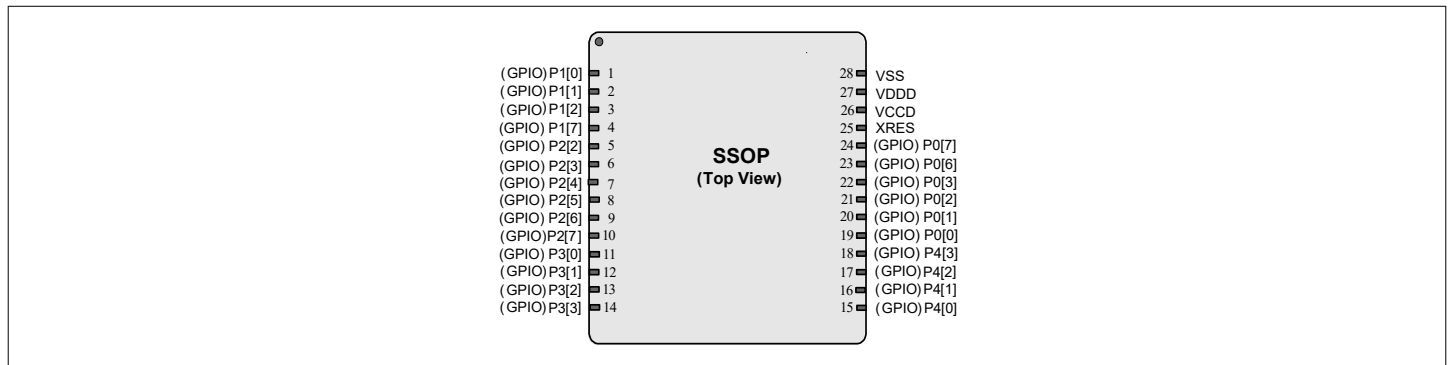

**Figure 4** 28-pin SSOP pinout

## PSoC™ 4: PSoC™ 4100

### 5 Power

## 5 Power

The following power system diagram shows the minimum set of power supply pins as implemented for PSoC™ 4100. The system has one regulator in Active mode for the digital circuitry. There is no analog regulator; the analog circuits run directly from the  $V_{DDA}$  input. There are separate regulators for the Deep Sleep and Hibernate (lowered power supply and retention) modes. There is a separate low-noise regulator for the bandgap. The supply voltage range is 1.71 to 5.5 V with all functions and circuits operating over that range.

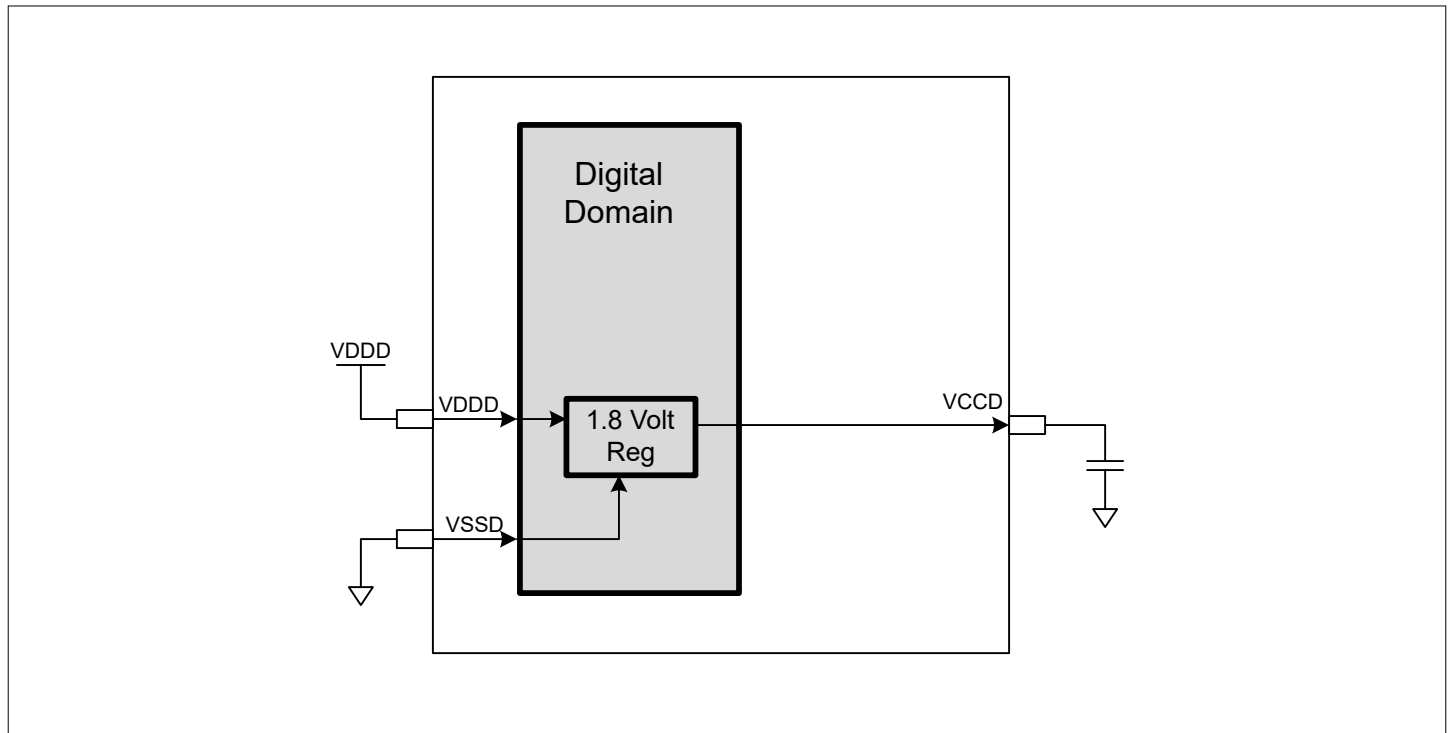

**Figure 5 PSoC™ 4 power supply**

The PSoC™ 4100 family allows two distinct modes of power supply operation: Unregulated External Supply, and Regulated External Supply modes.

### 5.1 Unregulated external supply

In this mode, the PSoC™ 4100 is powered by an External Power Supply that can be anywhere in the range of 1.8 to 5.5V. This range is also designed for battery-powered operation, for instance, the chip can be powered from a battery system that starts at 3.5V and works down to 1.8V. In this mode, the internal regulator of the PSoC™ 4100 supplies the internal logic and the VCCD output of the PSoC™ 4100 must be bypassed to ground via an external Capacitor (in the range of 1 to 1.6  $\mu\text{F}$ ; X5R ceramic or better).

Bypass capacitors must be used from VDDD to ground, typical practice for systems in this frequency range is to use a capacitor in the 1  $\mu\text{F}$  range in parallel with a smaller capacitor (0.1  $\mu\text{F}$  for example). Note that these are simply rules of thumb and that, for critical applications, the PCB layout, lead inductance, and the Bypass capacitor parasitic should be simulated to design and obtain optimal bypassing.

An example of a bypass scheme for the 28-pin SSOP package follows.

Power supply	Bypass capacitors
VDDD–VSS	0.1 $\mu\text{F}$ ceramic capacitor (C2) plus bulk capacitor 1 to 10 $\mu\text{F}$ (C1). Total Capacitance may be greater than 10 $\mu\text{F}$ .
VCCD–VSS	1 $\mu\text{F}$ ceramic capacitor at the VCCD pin (C3)

## PSoC™ 4: PSoC™ 4100

### 5 Power

Power supply	Bypass capacitors
VREF–VSS (optional)	The internal bandgap may be bypassed with a 1 $\mu\text{F}$ to 10 $\mu\text{F}$ capacitor. Total capacitance may be greater than 10 $\mu\text{F}$ .

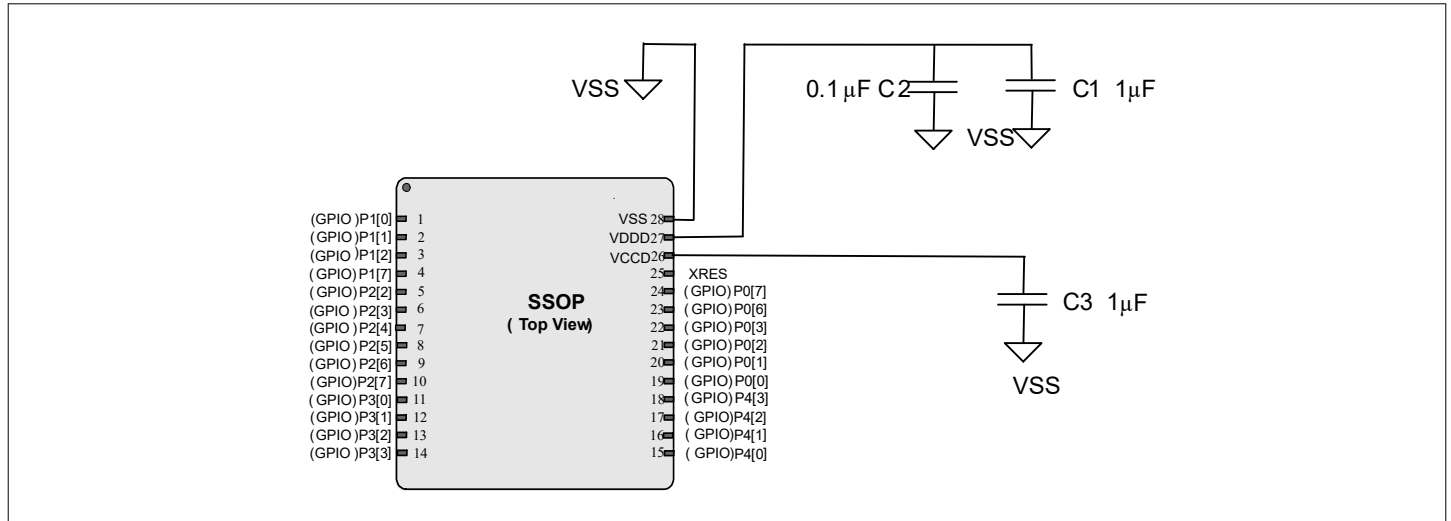

**Figure 6** 28-pin SSOP example

## 5.2 Regulated external supply

In this mode, the PSoC™ 4100 is powered by an external power supply that must be within the range of 1.71 to 1.89 V ( $1.8 \pm 5\%$ ); note that this range needs to include power supply ripple too. In this mode, VCCD, and VDD pins are all shorted together and bypassed. The internal regulator is disabled in firmware.

## PSoC™ 4: PSoC™ 4100

### 6 Development support

---

## 6 Development support

The PSoC™ 4100 family has a rich set of documentation, development tools, and online resources to assist you during your development process. Visit [webpage](#) to find out more.

### 6.1 Documentation

A suite of documentation supports the PSoC™ 4100 family to ensure that you can find answers to your questions quickly. This section contains a list of some of the key documents.

**Software user guide:** A step-by-step guide for using PSoC Creator. The software user guide shows you how the PSoC Creator build process works in detail, how to use source control with PSoC Creator, and much more.

**Component datasheets:** The flexibility of PSoC™ allows the creation of new peripherals (components) long after the device has gone into production. Component data sheets provide all of the information needed to select and use a particular component, including a functional description, API documentation, example code, and AC/DC specifications.

**Application notes:** PSoC™ application notes discuss a particular application of PSoC™ in depth; examples include brushless DC motor control and on-chip filtering. Application notes often include example projects in addition to the application note document.

**Technical reference manual:** The technical reference manual (TRM) contains all the technical detail you need to use a PSoC™ device, including a complete description of all PSoC™ registers. The TRM is available in the Documentation section in [webpage](#).

### 6.2 Online

In addition to print documentation, the Infineon PSoC™ forums connect you with fellow PSoC™ users and experts in PSoC™ from around the world, 24 hours a day, 7 days a week.

### 6.3 Tools

With industry standard cores, programming, and debugging interfaces, the PSoC™ 4100 family is part of a development tool ecosystem. Visit us at [PSoC Creator](#) for the latest information on the revolutionary, easy to use PSoC Creator IDE, supported third party compilers, programmers, debuggers, and development kits.

# PSoC™ 4: PSoC™ 4100

## 7 Electrical specifications

### 7 Electrical specifications

#### 7.1 Absolute maximum ratings

**Table 1** Absolute maximum ratings

Spec ID#	Parameter	Description	Min	Typ	Max	Units	Details/ conditions
SID1	V <sub>DDD_ABS</sub>	Digital supply relative to V <sub>SSD</sub>	-0.5	-	6	V	Absolute max
SID2	V <sub>CCD_ABS</sub>	Direct digital core voltage input relative to V <sub>SSD</sub>	-0.5	-	1.95	V	Absolute max
SID3	V <sub>GPIO_ABS</sub>	GPIO voltage	-0.5	-	V <sub>DD</sub> +0.5	V	Absolute max
SID4	I <sub>GPIO_ABS</sub>	Maximum current per GPIO	-25	-	25	mA	Absolute max
SID5	I <sub>GPIO_injection</sub>	GPIO injection current, Max for V <sub>IH</sub> > V <sub>DDD</sub> , and Min for V <sub>IL</sub> < V <sub>SS</sub>	-0.5	-	0.5	mA	Absolute max, current injected per pin
BID44	ESD_HBM	Electrostatic discharge human body model	2200	-	-	V	
BID45	ESD_CDM	Electrostatic discharge charged device model	500	-	-	V	
BID46	LU	Pin current for latch-up	-200	-	200	mA	

**Note:** Usage above the absolute maximum conditions listed in [Table 1](#) may cause permanent damage to the device. Exposure to absolute maximum conditions for extended periods of time may affect device reliability. The maximum storage temperature is 150 °C in compliance with JEDEC Standard JESD22-A103, High Temperature Storage Life. When used below absolute maximum conditions but above normal operating conditions, the device may not operate to specification.

## PSoC™ 4: PSoC™ 4100

### 7 Electrical specifications

#### 7.2 Device-level specifications

All specifications are valid for  $-40\text{ °C} \leq T_A \leq 85\text{ °C}$  for A grade devices and  $-40\text{ °C} \leq T_A \leq 105\text{ °C}$  for S grade devices, except where noted. Specifications are valid for 1.71 V to 5.5 V, except where noted.

**Table 2 DC specifications**

Spec ID#	Parameter	Description	Min	Typ	Max	Units	Details/ conditions
SID53	$V_{DD}$	Power supply input voltage ( $V_{DDA} = V_{DDD} = V_{DD}$ )	1.8	–	5.5	V	With regulator enabled
SID255	$V_{DDD}$	Power supply input voltage unregulated	1.71	1.8	1.89	V	Internally unregulated supply
SID54	$V_{CCD}$	Output voltage (for core logic)	–	1.8	–	V	
SID55	$C_{EFC}$	External regulator voltage bypass	1	1.3	1.6	$\mu\text{F}$	X5R ceramic or better
SID56	$C_{EXC}$	Power supply decoupling capacitor	–	1	–	$\mu\text{F}$	X5R ceramic or better

**Active Mode,  $V_{DD} = 1.71\text{ V to }5.5\text{ V}$ . Typical values measured at  $V_{DD} = 3.3\text{ V}$**

SID9	$I_{DD4}$	Execute from Flash; CPU at 6 MHz	–	–	2.8	mA	
SID10	$I_{DD5}$	Execute from Flash; CPU at 6 MHz	–	2.2	–	mA	$T = 25\text{ °C}$
SID12	$I_{DD7}$	Execute from Flash; CPU at 12 MHz	–	–	4.2	mA	
SID13	$I_{DD8}$	Execute from Flash; CPU at 12 MHz	–	3.7	–	mA	$T = 25\text{ °C}$
SID16	$I_{DD11}$	Execute from Flash; CPU at 24 MHz	–	6.7	–	mA	$T = 25\text{ °C}$
SID17	$I_{DD12}$	Execute from Flash; CPU at 24 MHz	–	–	7.2	mA	

(table continues...)

## PSoC™ 4: PSoC™ 4100

## 7 Electrical specifications

Table 2 (continued) DC specifications

Spec ID#	Parameter	Description	Min	Typ	Max	Units	Details/ conditions
Sleep Mode, $V_{DD} = 1.7\text{ V to }5.5\text{ V}$							
SID25	$I_{DD20}$	I <sup>2</sup> C wakeup, WDT, and Comparators on. 6 MHz	–	1.3	1.8	mA	$V_{DD} = 1.71\text{ V to }5.5\text{ V}$
SID25A	$I_{DD20A}$	I <sup>2</sup> C wakeup, WDT, and Comparators on. 12 MHz	–	1.7	2.2	mA	$V_{DD} = 1.71\text{ V to }5.5\text{ V}$
Deep Sleep Mode, $V_{DD} = 1.8\text{ V to }3.6\text{ V}$ (Regulator on)							
SID31	$I_{DD26}$	I <sup>2</sup> C wakeup and WDT on	–	1.3	–	μA	T = 25 °C
SID32	$I_{DD27}$	I <sup>2</sup> C wakeup and WDT on	–	–	45	μA	T = 85 °C
Deep Sleep Mode, $V_{DD} = 3.6\text{ V to }5.5\text{ V}$							
SID34	$I_{DD29}$	I <sup>2</sup> C wakeup and WDT on	–	1.5	15	μA	Typ at 25 °C Max at 85 °C
Deep Sleep Mode, $V_{DD} = 1.71\text{ V to }1.89\text{ V}$ (Regulator bypassed)							
SID37	$I_{DD32}$	I <sup>2</sup> C wakeup and WDT on	–	1.7	–	μA	T = 25 °C
SID38	$I_{DD33}$	I <sup>2</sup> C wakeup and WDT on	–	–	60	μA	T = 85 °C
Deep Sleep Mode, +105 °C							
SID33Q	$I_{DD28Q}$	I <sup>2</sup> C wakeup and WDT on. Regulator Off.	–	–	135	μA	$V_{DD} = 1.71\text{ V to }1.89\text{ V}$
SID34Q	$I_{DD29Q}$	I <sup>2</sup> C wakeup and WDT on	–	–	180	μA	$V_{DD} = 1.8\text{ V to }3.6\text{ V}$
SID35Q	$I_{DD30Q}$	I <sup>2</sup> C wakeup and WDT on	–	–	140	μA	$V_{DD} = 3.6\text{ V to }5.5\text{ V}$
Hibernate Mode, $V_{DD} = 1.8\text{ V to }3.6\text{ V}$ (Regulator on)							
SID40	$I_{DD35}$	GPIO & Reset active	–	150	–	nA	T = 25 °C
SID41	$I_{DD36}$	GPIO & Reset active	–	–	1000	nA	T = 85 °C
SID43	$I_{DD38}$	GPIO & Reset active	–	150	–	nA	T = 25 °C

(table continues...)

## PSoC™ 4: PSoC™ 4100

### 7 Electrical specifications

**Table 2** (continued) DC specifications

Spec ID#	Parameter	Description	Min	Typ	Max	Units	Details/ conditions
Hibernate Mode, $V_{DD} = 1.71\text{ V}$ to $1.89\text{ V}$ (Regulator bypassed)							
SID46	$I_{DD41}$	GPIO & Reset active	–	150	–	nA	$T = 25\text{ °C}$
SID47	$I_{DD42}$	GPIO & Reset active	–	–	1000	nA	$T = 85\text{ °C}$
Hibernate Mode, $+105\text{ °C}$							
SID42Q	$I_{DD37Q}$	Regulator Off	–	–	19.4	$\mu\text{A}$	$V_{DD} = 1.71\text{ V}$ to $1.89\text{ V}$
SID43Q	$I_{DD38Q}$		–	–	17	$\mu\text{A}$	$V_{DD} = 1.8\text{ V}$ to $3.6\text{ V}$
SID44Q	$I_{DD39Q}$		–	–	16	$\mu\text{A}$	$V_{DD} = 3.6\text{ V}$ to $5.5\text{ V}$
Stop Mode							
SID304	$I_{DD43A}$	Stop Mode current; $V_{DD} = 3.3\text{ V}$	–	20	80	nA	Typ at $25\text{ °C}$ Max at $85\text{ °C}$
		Stop Mode current; $V_{DD} = 5.5\text{ V}$	–	20	750	nA	Typ at $25\text{ °C}$ Max at $85\text{ °C}$
Stop Mode, $+105\text{ °C}$							
SID304Q	$I_{DD43AQ}$	Stop Mode current; $V_{DD} = 3.6\text{ V}$	–	–	5645	nA	
XRES current							
SID307	$I_{DD\_XR}$	Supply current while XRES asserted	–	2	5	mA	

### 7.2.1 GPIO

**Table 3** GPIO DC specifications

Spec ID#	Parameter	Description	Min	Typ	Max	Units	Details/ conditions
SID57	$V_{IH}^{1)}$	Input voltage high threshold	$0.7 \times V_{DD}$	–	–	V	CMOS Input

(table continues...)

## PSoC™ 4: PSoC™ 4100

## 7 Electrical specifications

Table 3 (continued) GPIO DC specifications

Spec ID#	Parameter	Description	Min	Typ	Max	Units	Details/ conditions
SID58	$V_{IL}$	Input voltage low threshold	–	–	$0.3 \times V_{DD3}$	V	CMOS Input
SID241	$V_{IH}^{1)}$	LVTTL input, $V_{DD3} < 2.7$ V	$0.7 \times V_{DD3}$	–	–	V	
SID242	$V_{IL}$	LVTTL input, $V_{DD3} < 2.7$ V	–	–	$0.3 \times V_{DD3}$	V	
SID243	$V_{IH}^{1)}$	LVTTL input, $V_{DD3} \geq 2.7$ V	2.0	–	–	V	
SID244	$V_{IL}$	LVTTL input, $V_{DD3} \geq 2.7$ V	–	–	0.8	V	
SID59	$V_{OH}$	Output voltage high level	$V_{DD3} - 0.6$	–	–	V	$I_{OH} = 4$ mA at $3 V_{DD3}$
SID60	$V_{OH}$	Output voltage high level	$V_{DD3} - 0.5$	–	–	V	$I_{OH} = 1$ mA at $1.8 V_{DD3}$
SID61	$V_{OL}$	Output voltage low level	–	–	0.6	V	$I_{OL} = 4$ mA at $1.8 V_{DD3}$
SID62	$V_{OL}$	Output voltage low level	–	–	0.6	V	$I_{OL} = 8$ mA at $3 V_{DD3}$
SID62A	$V_{OL}$	Output voltage low level	–	–	0.4	V	$I_{OL} = 3$ mA at $3 V_{DD3}$
SID63	$R_{PULLUP}$	Pull-up resistor	3.5	5.6	8.5	k $\Omega$	
SID64	$R_{PULLDOWN}$	Pull-down resistor	3.5	5.6	8.5	k $\Omega$	
SID65	$I_{IL}$	Input leakage current (absolute value)	–	–	2	nA	25 °C, $V_{DD3} = 3.0$ V
SID65A	$I_{IL\_CTBM}$	Input leakage current (absolute value) for CTBM pins	–	–	4	nA	

(table continues...)

## PSoC™ 4: PSoC™ 4100

### 7 Electrical specifications

**Table 3 (continued) GPIO DC specifications**

Spec ID#	Parameter	Description	Min	Typ	Max	Units	Details/ conditions
SID66	$C_{IN}$	Input capacitance	–	–	7	pF	
SID67	$V_{HYSTTL}$	Input hysteresis LVTTTL	25	40	–	mV	$V_{DD} \geq 2.7$ V. Guaranteed by characterization
SID68	$V_{HYSCMOS}$	Input hysteresis CMOS	$0.05 \times V_{DD}$	–	–	mV	Guaranteed by characterization
SID69	$I_{DIODE}$	Current through protection diode to $V_{DD}/V_{SS}$	–	–	100	$\mu$ A	Guaranteed by characterization
SID69A	$I_{TOT\_GPIO}$	Maximum Total Source or Sink Chip Current	–	–	200	mA	Guaranteed by characterization

1)  $V_{IH}$  must not exceed  $V_{DD} + 0.2$  V.

**Table 4 GPIO AC specifications**

(Guaranteed by characterization)

Spec ID#	Parameter	Description	Min	Typ	Max	Units	Details/ conditions
SID70	$T_{RISEF}$	Rise time in fast strong mode	2	–	12	ns	3.3 V $V_{DD}$ , Clod = 25 pF
SID71	$T_{FALLF}$	Fall time in fast strong mode	2	–	12	ns	3.3 V $V_{DD}$ , Clod = 25 pF
SID72	$T_{RISES}$	Rise time in slow strong mode	10	–	60		3.3 V $V_{DD}$ , Clod = 25 pF
SID73	$T_{FALLS}$	Fall time in slow strong mode	10	–	60		90/10%, 25 pF load, 60/40 duty cycle
SID74	$F_{GPIOUT1}$	GPIO Fout; $3.3 \text{ V} \leq V_{DD} \leq 5.5$ V. Fast strong mode.	–	–	24	MHz	90/10%, 25 pF load, 60/40 duty cycle
SID75	$F_{GPIOUT2}$	GPIO Fout; $1.7 \text{ V} \leq V_{DD} \leq 3.3$ V. Fast strong mode.	–	–	16.7	MHz	90/10%, 25 pF load, 60/40 duty cycle

(table continues...)

## PSoC™ 4: PSoC™ 4100

### 7 Electrical specifications

**Table 4 (continued) GPIO AC specifications**

(Guaranteed by characterization)

Spec ID#	Parameter	Description	Min	Typ	Max	Units	Details/ conditions
SID76	F <sub>GPIOOUT3</sub>	GPIO Fout; $3.3\text{ V} \leq V_{\text{DD}} \leq 5.5\text{ V}$ . Slow strong mode.	–	–	7	MHz	90/10%, 25 pF load, 60/40 duty cycle
SID245	F <sub>GPIOOUT4</sub>	GPIO Fout; $1.7\text{ V} \leq V_{\text{DD}} \leq 3.3\text{ V}$ . Slow strong mode.	–	–	3.5	MHz	90/10%, 25 pF load, 60/40 duty cycle
SID246	F <sub>GPIOIN</sub>	GPIO input operating frequency; $1.71\text{ V} \leq V_{\text{DD}} \leq 5.5\text{ V}$	–	–	24	MHz	90/10%, 25 pF load, 60/40 duty cycle

### 7.2.2 XRES

**Table 5 XRES DC specifications**

Spec ID#	Parameter	Description	Min	Typ	Max	Units	Details/ conditions
SID77	V <sub>IH</sub>	Input voltage high threshold	$0.7 \times V_{\text{DD}}$	–	–	V	CMOS Input
SID78	V <sub>IL</sub>	Input voltage low threshold	–	–	$0.3 \times V_{\text{DD}}$	V	CMOS Input
SID79	R <sub>PULLUP</sub>	Pull-up resistor	3.5	5.6	8.5	kΩ	
SID80	C <sub>IN</sub>	Input capacitance	–	3	–	pF	
SID81	V <sub>HYSXRES</sub>	Input voltage hysteresis	–	100	–	mV	Guaranteed by characterization
SID82	I <sub>DIODE</sub>	Current through protection diode to V <sub>DD</sub> /V <sub>SS</sub>	–	–	100	μA	Guaranteed by characterization

## PSoC™ 4: PSoC™ 4100

### 7 Electrical specifications

**Table 6 XRES AC specifications**

Spec ID#	Parameter	Description	Min	Typ	Max	Units	Details/ conditions
SID83	T <sub>RESETWIDTH</sub>	Reset pulse width	1	–	–	μs	Guaranteed by characterization

## 7.3 Analog peripherals

### 7.3.1 Opamp

**Table 7 Opamp specifications**

(Guaranteed by characterization)

Spec ID#	Parameter	Description	Min	Typ	Max	Units	Details/ conditions
	I <sub>DD</sub>	Opamp block current. No load.	–	–	–	–	
SID269	I <sub>DD_HI</sub>	Power = high	–	1100	1850	μA	
SID270	I <sub>DD_MED</sub>	Power = medium	–	550	950	μA	
SID271	I <sub>DD_LOW</sub>	Power = low	–	150	350	μA	
	GBW	Load = 20 pF, 0.1 mA. V <sub>DDA</sub> = 2.7 V	–	–	–	–	
SID272	GBW_HI	Power = high	6	–	–	MHz	
SID273	GBW_MED	Power = medium	4	–	–	MHz	
SID274	GBW_LO	Power = low	–	1	–	MHz	
	I <sub>OUT_MAX</sub>	V <sub>DDA</sub> ≥ 2.7 V, 500 mV from rail	–	–	–	–	
SID275	I <sub>OUT_MAX_HI</sub>	Power = high	10	–	–	mA	
SID276	I <sub>OUT_MAX_MID</sub>	Power = medium	10	–	–	mA	
SID277	I <sub>OUT_MAX_LO</sub>	Power = low	–	5	–	mA	
	I <sub>OUT</sub>	V <sub>DDA</sub> = 1.71 V, 500 mV from rail	–	–	–	–	

(table continues...)

## PSoC™ 4: PSoC™ 4100

### 7 Electrical specifications

**Table 7 (continued) Opamp specifications**

(Guaranteed by characterization)

Spec ID#	Parameter	Description	Min	Typ	Max	Units	Details/ conditions
SID278	I <sub>OUT_MAX_HI</sub>	Power = high	4	–	–	mA	
SID279	I <sub>OUT_MAX_MID</sub>	Power = medium	4	–	–	mA	
SID280	I <sub>OUT_MAX_LO</sub>	Power = low	–	2	–	mA	
SID281	V <sub>IN</sub>	Charge pump on, V <sub>DDA</sub> ≥ 2.7 V	–0.05	–	V <sub>DDA</sub> – 0.2	V	
SID282	V <sub>CM</sub>	Charge pump on, V <sub>DDA</sub> ≥ 2.7 V	–0.05	–	V <sub>DDA</sub> – 0.2	V	
	V <sub>OUT</sub>	V <sub>DDA</sub> ≥ 2.7 V	–	–	–		
SID283	V <sub>OUT_1</sub>	Power = high, I <sub>load</sub> =10 mA	0.5	–	V <sub>DDA</sub> – 0.5	V	
SID284	V <sub>OUT_2</sub>	Power = high, I <sub>load</sub> =1 mA	0.2	–	V <sub>DDA</sub> – 0.2	V	
SID285	V <sub>OUT_3</sub>	Power = medium, I <sub>load</sub> =1 mA	0.2	–	V <sub>DDA</sub> – 0.2	V	
SID286	V <sub>OUT_4</sub>	Power = low, I <sub>load</sub> =0.1mA	0.2	–	V <sub>DDA</sub> – 0.2	V	
SID288	V <sub>OS_TR</sub>	Offset voltage, trimmed	1	±0.5	1	mV	High mode
SID288A	V <sub>OS_TR</sub>	Offset voltage, trimmed	–	±1	–	mV	Medium mode
SID288B	V <sub>OS_TR</sub>	Offset voltage, trimmed	–	±2	–	mV	Low mode
SID290	V <sub>OS_DR_TR</sub>	Offset voltage drift, trimmed	–10	±3	10	μV/°C	High mode.T <sub>A</sub> < 85 °C.
SID290Q	V <sub>OS_DR_TR</sub>	Offset voltage drift, trimmed	–15	±3	15	μV/°C	High mode.T <sub>A</sub> ≤ 105 °C

(table continues...)

## PSoC™ 4: PSoC™ 4100

### 7 Electrical specifications

**Table 7 (continued) Opamp specifications**

(Guaranteed by characterization)

Spec ID#	Parameter	Description	Min	Typ	Max	Units	Details/ conditions
SID290A	V <sub>OS_DR_TR</sub>	Offset voltage drift, trimmed	–	±10	–	μV/°C	Medium mode
SID290B	V <sub>OS_DR_TR</sub>	Offset voltage drift, trimmed	–	±10	–	μV/°C	Low mode
SID291	CMRR	DC	70	80	–	dB	V <sub>DD</sub> = 3.6 V
SID292	PSRR	At 1 kHz, 100 mV ripple	70	85	–	dB	V <sub>DD</sub> = 3.6 V
	Noise		–	–	–	–	
SID293	V <sub>N1</sub>	Input referred, 1 Hz - 1GHz, power = high	–	94	–	μVrms	
SID294	V <sub>N2</sub>	Input referred, 1 kHz, power = high	–	72	–	nV/rtHz	
SID295	V <sub>N3</sub>	Input referred, 10kHz, power = high	–	28	–	nV/rtHz	
SID296	V <sub>N4</sub>	Input referred, 100kHz, power = high	–	15	–	nV/rtHz	
SID297	Cload	Stable up to maximum load. Performance specs at 50 pF.	–	–	125	pF	
SID298	Slew_rate	Cload = 50 pF, Power = High, V <sub>D</sub> ≥ 2.7 V	6	–	–	V/μs	
SID299	T <sub>op_wake</sub>	From disable to enable, no external RC dominating	–	300	–	μs	

(table continues...)

## PSoC™ 4: PSoC™ 4100

### 7 Electrical specifications

**Table 7 (continued) Opamp specifications**

(Guaranteed by characterization)

Spec ID#	Parameter	Description	Min	Typ	Max	Units	Details/ conditions
	Comp_mode	Comparator mode; 50 mV drive, Trise = Tfall (approx.)	–	–	–		
SID299A	OL_GAIN	Open Loop Gain	–	90	–	dB	Guaranteed by Design
SID300	T <sub>PD1</sub>	Response time; power = high	–	150	–	ns	
SID301	T <sub>PD2</sub>	Response time; power = medium	–	400	–	ns	
SID302	T <sub>PD3</sub>	Response time; power = low	–	2000	–	ns	
SID303	Vhyst_op	Hysteresis	–	10	–	mV	

### 7.3.2 Comparator

**Table 8 Comparator DC specifications**

Spec ID#	Parameter	Description	Min	Typ	Max	Units	Details/ conditions
SID85	V <sub>OFFSET2</sub>	Input offset voltage, Common Mode voltage range from 0 to V <sub>DD</sub> -1	–	–	±4	mV	
SID85A	V <sub>OFFSET3</sub>	Input offset voltage. Ultra low-power mode (V <sub>DDD</sub> ≥ 2.2 V for Temp < 0 °C, V <sub>DDD</sub> ≥ 1.8 V for Temp > 0 °C)	–	±12	–	mV	

(table continues...)

## PSoC™ 4: PSoC™ 4100

## 7 Electrical specifications

Table 8 (continued) Comparator DC specifications

Spec ID#	Parameter	Description	Min	Typ	Max	Units	Details/ conditions
SID86	V <sub>HYST</sub>	Hysteresis when enabled, Common Mode voltage range from 0 to V <sub>DD</sub> -1.	–	10	35	mV	Guaranteed by characterization
SID87	V <sub>ICM1</sub>	Input common mode voltage in normal mode	0	–	V <sub>DDD</sub> - 0.1	V	Modes 1 and 2.
SID247	V <sub>ICM2</sub>	Input common mode voltage in low power mode (V <sub>DDD</sub> ≥ 2.2 V for Temp < 0 °C, V <sub>DDD</sub> ≥ 1.8 V for Temp > 0 °C)	0	–	V <sub>DDD</sub>	V	
SID247A	V <sub>ICM3</sub>	Input common mode voltage in ultra low power mode	0	–	V <sub>DDD</sub> - 1.15	V	
SID88	CMRR	Common mode rejection ratio	50	–	–	dB	V <sub>DDD</sub> ≥ 2.7 V. Guaranteed by characterization
SID88A	CMRR	Common mode rejection ratio	42	–	–	dB	V <sub>DDD</sub> < 2.7 V. Guaranteed by characterization

(table continues...)

## PSoC™ 4: PSoC™ 4100

### 7 Electrical specifications

**Table 8 (continued) Comparator DC specifications**

Spec ID#	Parameter	Description	Min	Typ	Max	Units	Details/ conditions
SID89	$I_{CMP1}$	Block current, normal mode	–	–	400	$\mu\text{A}$	Guaranteed by characterization
SID248	$I_{CMP2}$	Block current, low power mode	–	–	100	$\mu\text{A}$	Guaranteed by characterization
SID259	$I_{CMP3}$	Block current, ultra low power mode ( $V_{DD} \geq 2.2\text{ V}$ for Temp $< 0\text{ }^\circ\text{C}$ , $V_{DD} \geq 1.8\text{ V}$ for Temp $> 0\text{ }^\circ\text{C}$ )	–	6	28	$\mu\text{A}$	Guaranteed by characterization
SID90	$Z_{CMP}$	DC input impedance of comparator	35	–	–	$\text{M}\Omega$	Guaranteed by characterization

**Table 9 Comparator AC specifications**

Guaranteed by characterization

Spec ID#	Parameter	Description	Min	Typ	Max	Units	Details/ conditions
SID91	$T_{RESP1}$	Response time, normal mode	–	–	110	ns	50 mV overdrive
SID258	$T_{RESP2}$	Response time, low power mode	–	–	200	ns	50 mV overdrive
SID92	$T_{RESP3}$	Response time, ultra low power mode ( $V_{DD} \geq 2.2\text{ V}$ for Temp $< 0\text{ }^\circ\text{C}$ , $V_{DD} \geq 1.8\text{ V}$ for Temp $> 0\text{ }^\circ\text{C}$ )	–	–	15	$\mu\text{s}$	200 mV overdrive

## PSoC™ 4: PSoC™ 4100

### 7 Electrical specifications

#### 7.3.3 Temperature sensor

**Table 10** Temperature sensor specifications

Spec ID#	Parameter	Description	Min	Typ	Max	Units	Details/ conditions
SID93	T <sub>SENSACC</sub>	Temperature sensor accuracy	-5	±1	+5	°C	-40 to +85 °C

#### 7.3.4 SAR ADC

**Table 11** SAR ADC DC specifications

Spec ID#	Parameter	Description	Min	Typ	Max	Units	Details/ conditions
SID94	A_RES	Resolution	-	-	12	bits	
SID95	A_CHNIS_S	Number of channels - single ended	-	-	8		8 full speed
SID96	A-CHNKS_D	Number of channels - differential	-	-	4		Diff inputs use neighboring I/O
SID97	A-MONO	Monotonicity	-	-	-		Yes. Based on characterization
SID98	A_GAINERR	Gain error	-	-	±0.1	%	With external reference. Guaranteed by characterization
SID99	A_OFFSET	Input offset voltage	-	-	2	mV	Measured with 1-V V <sub>REF</sub> . Guaranteed by characterization
SID100	A_ISAR	Current consumption	-	-	1	mA	
SID101	A_VINS	Input voltage range - single ended	V <sub>SS</sub>	-	V <sub>DDA</sub>	V	Based on device characterization

(table continues...)

## PSoC™ 4: PSoC™ 4100

### 7 Electrical specifications

**Table 11** (continued) SAR ADC DC specifications

Spec ID#	Parameter	Description	Min	Typ	Max	Units	Details/ conditions
SID102	A_VIND	Input voltage range - differential	$V_{SS}$	–	$V_{DDA}$	V	Based on device characterization
SID103	A_INRES	Input resistance	–	–	2.2	k $\Omega$	Based on device characterization
SID104	A_INCAP	Input capacitance	–	–	10	pF	Based on device characterization

**Table 12** SAR ADC AC specifications

(Guaranteed by characterization)

Spec ID#	Parameter	Description	Min	Typ	Max	Units	Details/ conditions
SID106	A_PSRR	Power supply rejection ratio	70	–	–	dB	
SID107	A_CMRR	Common mode rejection ratio	66	–	–	dB	Measured at 1 V
SID108	A_SAMP_1	Sample rate with external reference bypass cap	–	–	1	Msp	
SID108A	A_SAMP_2	Sample rate with no bypass cap. Reference = VDD	–	–	806	Ksps	
SID108B	A_SAMP_3	Sample rate with no bypass cap. Internal reference	–	–	100	Ksps	

(table continues...)

## PSoC™ 4: PSoC™ 4100

### 7 Electrical specifications

**Table 12 (continued) SAR ADC AC specifications**

(Guaranteed by characterization)

Spec ID#	Parameter	Description	Min	Typ	Max	Units	Details/ conditions
SID109	A_SNDR	Signal-to-noise and distortion ratio (SINAD)	65	–	–	dB	$F_{IN} = 10 \text{ kHz}$
SID111	A_INL	Integral non linearity	-1.7	–	+2	LSB	$V_{DD} = 1.71 \text{ to } 5.5, 806 \text{ Ksps}, V_{ref} = 1 \text{ to } 5.5. -40 \text{ }^\circ\text{C} \leq T_A \leq 85 \text{ }^\circ\text{C}$
			-1.9	–	+2	LSB	$V_{DD} = 1.71 \text{ to } 5.5, 806 \text{ Ksps}, V_{ref} = 1 \text{ to } 5.5. -40 \text{ }^\circ\text{C} \leq T_A \leq 105 \text{ }^\circ\text{C}$
SID111A	A_INL	Integral non linearity	-1.5	–	+1.7	LSB	$V_{DDD} = 1.71 \text{ to } 3.6, 806 \text{ Ksps}, V_{ref} = 1.71 \text{ to } V_{DDD}. -40 \text{ }^\circ\text{C} \leq T_A \leq 85 \text{ }^\circ\text{C}$
			-1.9	–	+2	LSB	$V_{DDD} = 1.71 \text{ to } 3.6, 806 \text{ Ksps}, V_{ref} = 1.71 \text{ to } V_{DDD}. -40 \text{ }^\circ\text{C} \leq T_A \leq 105 \text{ }^\circ\text{C}$
SID111B	A_INL	Integral non linearity	-1.5	–	+1.7	LSB	$V_{DDD} = 1.71 \text{ to } 5.5, 500 \text{ Ksps}, V_{ref} = 1 \text{ to } 5.5.$
SID112	A_DNL	Differential non linearity	-1	–	+2.2	LSB	$V_{DDD} = 1.71 \text{ to } 5.5, 806 \text{ Ksps}, V_{ref} = 1 \text{ to } 5.5. -40 \text{ }^\circ\text{C} \leq T_A \leq 85 \text{ }^\circ\text{C}$
			-1	–	+2.3	LSB	$V_{DDD} = 1.71 \text{ to } 5.5, 806 \text{ Ksps}, V_{ref} = 1 \text{ to } 5.5. -40 \text{ }^\circ\text{C} \leq T_A \leq 105 \text{ }^\circ\text{C}$

(table continues...)

## PSoC™ 4: PSoC™ 4100

### 7 Electrical specifications

**Table 12 (continued) SAR ADC AC specifications**

(Guaranteed by characterization)

Spec ID#	Parameter	Description	Min	Typ	Max	Units	Details/ conditions
SID112A	A_DNL	Differential non linearity	-1	-	+2	LSB	$V_{DD} = 1.71$ to 3.6, 806 Ksps, $V_{ref} = 1.71$ to $V_{DD}$ . $-40\text{ }^{\circ}\text{C} \leq T_A \leq 85\text{ }^{\circ}\text{C}$
			-1	-	+2.2	LSB	$V_{DD} = 1.71$ to 3.6, 806 Ksps, $V_{ref} = 1.71$ to $V_{DD}$ . $-40\text{ }^{\circ}\text{C} \leq T_A \leq 105\text{ }^{\circ}\text{C}$
SID112B	A_DNL	Differential non linearity	-1	-	+2.2	LSB	$V_{DD} = 1.71$ to 5.5, 500 Ksps, $V_{ref} = 1$ to 5.5.
SID113	A_THD	Total harmonic distortion	-	-	-65	dB	$F_{IN} = 10\text{ kHz}$ .

### 7.3.5 CSD

**Table 13 CSD block specification**

Spec ID#	Parameter	Description	Min	Typ	Max	Units	Details/ conditions
<b>CSD specification</b>							
SID308	VCSD	Voltage range of operation	1.71	-	5.5	V	
SID309	IDAC1	DNL for 8-bit resolution	-1	-	1	LSB	
SID310	IDAC1	INL for 8-bit resolution	-3	-	3	LSB	
SID311	IDAC2	DNL for 7-bit resolution	-1	-	1	LSB	
SID312	IDAC2	INL for 7-bit resolution	-3	-	3	LSB	

(table continues...)

## PSoC™ 4: PSoC™ 4100

### 7 Electrical specifications

**Table 13** (continued) CSD block specification

Spec ID#	Parameter	Description	Min	Typ	Max	Units	Details/ conditions
SID313	SNR	Ratio of counts of finger to noise. Guaranteed by characterization	5	–	–	Ratio	Capacitance range of 9 to 35 pF, 0.1 pF sensitivity
SID314	IDAC1_CRT1	Output current of Idac1 (8-bits) in High range	–	612	–	μA	
SID314A	IDAC1_CRT2	Output current of Idac1(8-bits) in Low range	–	306	–	μA	
SID315	IDAC2_CRT1	Output current of Idac2 (7-bits) in High range	–	304.8	–	μA	
SID315A	IDAC2_CRT2	Output current of Idac2 (7-bits) in Low range	–	152.4	–	μA	

## 7.4 Digital peripherals

The following specifications apply to the Timer/Counter/PWM peripherals in the Timer mode.

### 7.4.1 Timer/Counter/PWM

**Table 14** TCPWM specifications

(Guaranteed by characterization)

Spec ID	Parameter	Description	Min	Typ	Max	Units	Details/ conditions
SID.TCPWM.1	ITCPWM1	Block current consumption at 3 MHz	–	–	45	μA	All modes(Timer/Counter/PWM)
SID.TCPWM.2	ITCPWM2	Block current consumption at 12 MHz	–	–	155	μA	All modes(Timer/Counter/PWM)

(table continues...)

## PSoC™ 4: PSoC™ 4100

### 7 Electrical specifications

**Table 14 (continued) TCPWM specifications**

(Guaranteed by characterization)

Spec ID	Parameter	Description	Min	Typ	Max	Units	Details/ conditions
SID.TCPWM.2 A	ITCPWM3	Block current consumption at 48 MHz	–	–	650	μA	All modes(Time r/Counter/PWM)
SID.TCPWM.3	TCPWMFREQ	Operating frequency	–	–	Fc	MHz	Fc max = Fcpu. Maximum = 24 MHz
SID.TCPWM.4	TPWMENEXT	Input Trigger Pulse Width for all Trigger Events	2/Fc	–	–	ns	Trigger Events can be Stop, Start, Reload, Count, Capture, or Kill depending on which mode of operation is selected.
SID.TCPWM.5	TPWMEXT	Output Trigger Pulse widths	2/Fc	–	–	ns	Minimum possible width of Overflow, Underflow, and CC (Counter equals Compare value) trigger outputs
SID.TCPWM.5 A	TCRES	Resolution of Counter	1/Fc	–	–	ns	Minimum time between successive counts
SID.TCPWM.5 B	PWMRES	PWM Resolution	1/Fc	–	–	ns	Minimum pulse width of PWM Output

(table continues...)

## PSoC™ 4: PSoC™ 4100

### 7 Electrical specifications

**Table 14 (continued) TCPWM specifications**

(Guaranteed by characterization)

Spec ID	Parameter	Description	Min	Typ	Max	Units	Details/ conditions
SID.TCPWM.5 C	QRES	Quadrature inputs resolution	1/Fc	–	–	ns	Minimum pulse width between Quadrature phase inputs.

NOT YET CONVERTED: 0paragraph

### 7.4.2 I2C

**Table 15 Fixed I<sup>2</sup>C DC specifications**

(Guaranteed by characterization)

Spec ID	Parameter	Description	Min	Typ	Max	Units	Details/ conditions
SID149	I <sub>I2C1</sub>	Block current consumption at 100 kHz	–	–	50	pA	
SID150	I <sub>I2C2</sub>	Block current consumption at 400 kHz	–	–	135	pA	
SID151	I <sub>I2C3</sub>	Block current consumption at 1 Mbps	–	–	310	pA	
SID152	I <sub>I2C4</sub>	I <sup>2</sup> C enabled in Deep Sleep mode	–	–	1.4	pA	

### 7.4.3 LCD direct drive

**Table 16 LCD direct drive DC specifications**

(Guaranteed by characterization)

Spec ID	Parameter	Description	Min	Typ	Max	Units	Details/ conditions
SID154	I <sub>LCDLOW</sub>	Operating current in low power mode	–	5	–	μA	16 × 4 small segment disp. at 50 Hz

(table continues...)

## PSoC™ 4: PSoC™ 4100

### 7 Electrical specifications

**Table 16 (continued) LCD direct drive DC specifications**

(Guaranteed by characterization)

Spec ID	Parameter	Description	Min	Typ	Max	Units	Details/ conditions
SID155	C <sub>LCDCAP</sub>	LCD capacitance per segment/ common driver	–	500	5000	pF	Guaranteed by Design
SID156	LCD <sub>OFFSET</sub>	Long-term segment offset	–	20	–	mV	
SID157	I <sub>LCDDOP1</sub>	PWM Mode current. 5-V bias. 24-MHz IMO. 25 °C	–	0.6	–	mA	32 × 4 segments. 50 Hz
SID158	I <sub>LCDDOP2</sub>	PWM Mode current. 3.3-V bias. 24-MHz IMO. 25 °C	–	0.5	–	mA	32 × 4 segments. 50 Hz

**Table 17 LCD direct drive AC specifications**

(Guaranteed by characterization)

Spec ID	Parameter	Description	Min	Typ	Max	Units	Details/ conditions
SID159	F <sub>LCD</sub>	LCD frame rate	10	50	150	Hz	

**Table 18 Fixed UART DC specifications**

(Guaranteed by characterization)

Spec ID	Parameter	Description	Min	Typ	Max	Units	Details/ conditions
SID160	I <sub>UART1</sub>	Block current consumption at 100 Kbits/sec	–	–	55	μA	
SID161	I <sub>UART2</sub>	Block current consumption at 1000 Kbits/sec	–	–	312	μA	

## PSoC™ 4: PSoC™ 4100

### 7 Electrical specifications

**Table 19 Fixed UART AC specifications**

(Guaranteed by characterization)

Spec ID	Parameter	Description	Min	Typ	Max	Units
SID162	F <sub>UART</sub>	Bit rate	–	–	1	Mbps

### 7.4.4 SPI specifications

**Table 20 Fixed SPI DC specifications**

(Guaranteed by characterization)

Spec ID	Parameter	Description	Min	Typ	Max	Units
SID163	I <sub>SPI1</sub>	Block current consumption at 1 Mbits/sec	–	–	360	μA
SID164	I <sub>SPI2</sub>	Block current consumption at 4 Mbits/sec	–	–	560	μA
SID165	I <sub>SPI3</sub>	Block current consumption at 8 Mbits/sec	–	–	600	μA

**Table 21 Fixed SPI AC specifications**

(Guaranteed by characterization)

Spec ID	Parameter	Description	Min	Typ	Max	Units
SID166	F <sub>SPI</sub>	SPI operating frequency (master; 6X oversampling)	–	–	4	MHz

**Table 22 Fixed SPI Master mode AC specifications**

(Guaranteed by characterization)

Spec ID	Parameter	Description	Min	Typ	Max	Units
SID167	T <sub>D<sub>MO</sub></sub>	MOSI valid after S <sub>clock</sub> driving edge	–	–	15	ns
SID168	T <sub>D<sub>SI</sub></sub>	MISO valid before S <sub>clock</sub> capturing edge. Full clock, late MISO Sampling used	20	–	–	ns

(table continues...)

## PSoC™ 4: PSoC™ 4100

### 7 Electrical specifications

**Table 22 (continued) Fixed SPI Master mode AC specifications**

(Guaranteed by characterization)

Spec ID	Parameter	Description	Min	Typ	Max	Units
SID169	$T_{HMO}$	Previous MOSI data hold time with respect to capturing edge at Slave	0	–	–	ns

**Table 23 Fixed SPI Slave mode AC specifications**

(Guaranteed by characterization)

Spec ID	Parameter	Description	Min	Typ	Max	Units	Details/ conditions
SID170	$T_{DMI}$	MOSI valid before Sclock capturing edge	40	–	–	ns	
SID171	$T_{DSO}$	MISO valid after Sclock driving edge	–	–	$42 + 3 \times T_{scbclk}$	ns	
SID171A	$T_{DSO\_ext}$	MISO valid after Sclock driving edge in Ext. Clock mode	–	–	48	ns	
SID172	$T_{HSO}$	Previous MISO data hold time	0	–	–	ns	
SID172A	$T_{SSELCK}$	SSEL Valid to first SCK Valid edge	100	–	–	ns	

## 7.5 Memory

**Table 24 Flash DC specifications**

Spec ID	Parameter	Description	Min	Typ	Max	Units	Details/ conditions
SID173	$V_{PE}$	Erase and program voltage	1.71	–	5.5	V	

## PSoC™ 4: PSoC™ 4100

## 7 Electrical specifications

Table 25 Flash AC specifications

Spec ID	Parameter	Description	Min	Typ	Max	Units	Details/ conditions
SID174	$T_{\text{ROWWRITE}}^{1)}$	Row (block) write time (erase and program)	-	-	20	ms	Row (block) =128 bytes. -40 °C ≤ T <sub>A</sub> ≤ 85 °C
			-	-	26	ms	Row (block) =128 bytes. -40 °C ≤ T <sub>A</sub> ≤ 105 °C
SID175	$T_{\text{ROWERASE}}^{1)}$	Row erase time	-	-	13	ms	
SID176	$T_{\text{ROWPROGRAM}}^{1)}$	Row program time after erase	-	-	7	ms	-40 °C ≤ T <sub>A</sub> ≤ 85 °C
			-	-	13	ms	-40 °C ≤ T <sub>A</sub> ≤ 105 °C
SID178	$T_{\text{BULKERASE}}^{1)}$	Bulk erase time (32 KB)	-	-	35	ms	
SID180	$T_{\text{DEVPROG}}^{1)}$	Total device program time	-	-	7	seconds	Guaranteed by characterization
SID181	F <sub>END</sub>	Flash endurance	100 K	-	-	cycles	Guaranteed by characterization
SID182	F <sub>RET</sub>	Flash retention. T <sub>A</sub> ≤ 55 °C, 100 K P/E cycles	20	-	-	years	Guaranteed by characterization
SID182A		Flash retention. T <sub>A</sub> ≤ 85 °C, 10 K P/E cycles	10	-	-	years	Guaranteed by characterization
SID182B	F <sub>RETQ</sub>	Flash retention. T <sub>A</sub> ≤ 105 °C, 10K P/E cycles, ≤ three years at T <sub>A</sub> > 85 °C.	10	20	-		Guaranteed by characterization.

1) It can take as much as 20 milliseconds to write to Flash. During this time the device should not be Reset, or Flash operations will be interrupted and cannot be relied on to have completed. Reset sources include the XRES pin, software resets, CPU lockup states and privilege violations, improper power supply levels, and watchdogs. Make certain that these are not inadvertently activated.

## PSoC™ 4: PSoC™ 4100

### 7 Electrical specifications

## 7.6 System resources

### 7.6.1 Power-on-Reset (POR) with Brown Out

**Table 26 Imprecise Power On Reset (PRES)**

Spec ID	Parameter	Description	Min	Typ	Max	Units	Details/ conditions
SID185	V <sub>RISEIPOR</sub>	Rising trip voltage	0.80	–	1.45	V	Guaranteed by characterization
SID186	V <sub>FALLIPOR</sub>	Falling trip voltage	0.75	–	1.4	V	Guaranteed by characterization
SID187	V <sub>IPORHYST</sub>	Hysteresis	15	–	200	mV	Guaranteed by characterization

**Table 27 Precise Power On Reset (POR)**

Spec ID	Parameter	Description	Min	Typ	Max	Units	Details/ conditions
SID190	V <sub>FALLPPOR</sub>	BOD trip voltage in active and sleep modes	1.64	–	–	V	Full functionality between 1.71 V and BOD trip voltage is guaranteed by characterization
SID192	V <sub>FALLDPSLP</sub>	BOD trip voltage in Deep Sleep	1.4	–	–	V	Guaranteed by characterization
BID55	Svdd	Maximum power supply ramp rate	–	–	67	kV/sec	

## PSoC™ 4: PSoC™ 4100

### 7 Electrical specifications

#### 7.6.2 Voltage monitors

**Table 28** Voltage monitors DC specifications

Spec ID	Parameter	Description	Min	Typ	Max	Units	Details/ conditions
SID195	V <sub>LVI1</sub>	LVI_A/ D_SEL[3:0] = 0000b	1.71	1.75	1.79	V	
SID196	V <sub>LVI2</sub>	LVI_A/ D_SEL[3:0] = 0001b	1.76	1.80	1.85	V	
SID197	V <sub>LVI3</sub>	LVI_A/ D_SEL[3:0] = 0010b	1.85	1.90	1.95	V	
SID198	V <sub>LVI4</sub>	LVI_A/ D_SEL[3:0] = 0011b	1.95	2.00	2.05	V	
SID199	V <sub>LVI5</sub>	LVI_A/ D_SEL[3:0] = 0100b	2.05	2.10	2.15	V	
SID200	V <sub>LVI6</sub>	LVI_A/ D_SEL[3:0] = 0101b	2.15	2.20	2.26	V	
SID201	V <sub>LVI7</sub>	LVI_A/ D_SEL[3:0] = 0110b	2.24	2.30	2.36	V	
SID202	V <sub>LVI8</sub>	LVI_A/ D_SEL[3:0] = 0111b	2.34	2.40	2.46	V	
SID203	V <sub>LVI9</sub>	LVI_A/ D_SEL[3:0] = 1000b	2.44	2.50	2.56	V	
SID204	V <sub>LVI10</sub>	LVI_A/ D_SEL[3:0] = 1001b	2.54	2.60	2.67	V	
SID205	V <sub>LVI11</sub>	LVI_A/ D_SEL[3:0] = 1010b	2.63	2.70	2.77	V	
SID206	V <sub>LVI12</sub>	LVI_A/ D_SEL[3:0] = 1011b	2.73	2.80	2.87	V	
SID207	V <sub>LVI13</sub>	LVI_A/ D_SEL[3:0] = 1100b	2.83	2.90	2.97	V	

(table continues...)

## PSoC™ 4: PSoC™ 4100

### 7 Electrical specifications

**Table 28** (continued) Voltage monitors DC specifications

Spec ID	Parameter	Description	Min	Typ	Max	Units	Details/ conditions
SID208	V <sub>LVI14</sub>	LVI_A/ D_SEL[3:0] = 1101b	2.93	3.00	3.08	V	
SID209	V <sub>LVI15</sub>	LVI_A/ D_SEL[3:0] = 1110b	3.12	3.20	3.28	V	
SID210	V <sub>LVI16</sub>	LVI_A/ D_SEL[3:0] = 1111b	4.39	4.50	4.61	V	
SID211	LVI_IDD	Block current	–	–	100	μA	Guaranteed by characterizat ion

**Table 29** Voltage monitors AC specifications

Spec ID	Parameter	Description	Min	Typ	Max	Units	Details/ conditions
SID212	T <sub>MONTRIP</sub>	Voltage monitor trip time	–	–	1	μs	Guaranteed by characterizat ion

### 7.6.3 SWD interface

**Table 30** SWD interface specifications

Spec ID	Parameter	Description	Min	Typ	Max	Units	Details/ conditions
SID213	F_SWDCCLK1	$3.3\text{ V} \leq V_{DD} \leq 5.5\text{ V}$	–	–	14	MHz	SWDCCLK ≤ 1/3 CPU clock frequency
SID214	F_SWDCCLK2	$1.71\text{ V} \leq V_{DD} \leq 3.3\text{ V}$	–	–	7	MHz	SWDCCLK ≤ 1/3 CPU clock frequency
SID215	T_SWDI_SET UP	$T = 1/f$ SWDCCLK	0.25*T	–	–	ns	Guaranteed by characterizat ion

(table continues...)

## PSoC™ 4: PSoC™ 4100

### 7 Electrical specifications

**Table 30** (continued) SWD interface specifications

Spec ID	Parameter	Description	Min	Typ	Max	Units	Details/ conditions
SID216	T_SWDI_HOLD	T = 1/f SWDCLK	0.25*T	–	–	ns	Guaranteed by characterizat ion
SID217	T_SWDO_VA LID	T = 1/f SWDCLK	–	–	0.5*T	ns	Guaranteed by characterizat ion
SID217A	T_SWDO_HO LD	T = 1/f SWDCLK	1	–	–	ns	Guaranteed by characterizat ion

### 7.6.4 Internal main oscillator

**Table 31** IMO DC specifications

(Guaranteed by design)

Spec ID	Parameter	Description	Min	Typ	Max	Units	Details/ conditions
SID219	I <sub>IMO2</sub>	IMO operating current at 24 MHz	–	–	325	pA	
SID220	I <sub>IMO3</sub>	IMO operating current at 12 MHz	–	–	225	pA	
SID221	I <sub>IMO4</sub>	IMO operating current at 6 MHz	–	–	180	pA	
SID222	I <sub>IMO5</sub>	IMO operating current at 3 MHz	–	–	150	pA	

## PSoC™ 4: PSoC™ 4100

### 7 Electrical specifications

**Table 32** IMO AC specifications

Spec ID	Parameter	Description	Min	Typ	Max	Units	Details/ conditions
SID223	F <sub>IMOTOL1</sub>	Frequency variation from 3 to 48 MHz	–	–	±2	%	+3% if T <sub>A</sub> > 85 °C and IMO frequency < 24 MHz
SID226	T <sub>STARTIMO</sub>	IMO startup time	–	–	12	µs	
SID227	T <sub>JITRMSIM01</sub>	RMS Jitter at 3 MHz	–	156	–	ps	
SID228	T <sub>JITRMSIM02</sub>	RMS Jitter at 24 MHz	–	145	–	ps	

### 7.6.5 Internal low-speed oscillator

**Table 33** ILO DC specifications

(Guaranteed by design)

Spec ID	Parameter	Description	Min	Typ	Max	Units	Details/ conditions
SID231	I <sub>ILO1</sub>	ILO operating current at 32 kHz	–	0.3	1.05	µA	Guaranteed by characterization
SID233	I <sub>ILOLEAK</sub>	ILO leakage current	–	2	15	nA	Guaranteed by design

**Table 34** ILO AC specifications

Spec ID	Parameter	Description	Min	Typ	Max	Units	Details/ conditions
SID234	T <sub>STARTILO1</sub>	ILO startup time	–	–	2	ms	Guaranteed by characterization
SID236	T <sub>ILODUTY</sub>	ILO duty cycle	40	50	60	%	Guaranteed by characterization
SID237	F <sub>ILOTRIM1</sub>	32 kHz trimmed frequency	15	32	50	kHz	Max. ILO frequency is 70 kHz if T <sub>A</sub> > 85 °C

## PSoC™ 4: PSoC™ 4100

### 7 Electrical specifications

**Table 35 External clock specifications**

Spec ID	Parameter	Description	Min	Typ	Max	Units	Details/ conditions
SID305	ExtClkFreq	External Clock input Frequency	0	–	48	MHz	Guaranteed by characterization
SID306	ExtClkDuty	Duty cycle; Measured at $V_{DD/2}$	45	–	55	%	Guaranteed by characterization

**Table 36 Block specs**

Spec ID	Parameter	Description	Min	Typ	Max	Units	Details/ conditions
SID257	TWS24*	Number of wait states at 24 MHz	0	–	–		CPU execution fromFlash. Guaranteed by characterization
SID260	VREFSAR	Trimmed internal reference to SAR	–1	–	+1	%	Percentage of Vbg (1.024 V). Guaranteed by characterization
SID262	TCLKSWITCH	Clock switching from clk1 to clk2 in clk1 periods	3	–	4	Periods	Guaranteed bydesign

\*Tws24 is guaranteed by Design

## PSoC™ 4: PSoC™ 4100

### 8 Ordering information

## 8 Ordering information

The PSoC™ 4100 part numbers and features are listed in the [Table 37](#).

**Table 37 PSoC™ 4100 family ordering information**

Family	Product	Features												Package	Operating temperature	
		Max CPU speed (MHz)	Flash (KB)	SRAM (KB)	UDB	Opamp (CTBm)	CAPSENSE™	Direct LCD drive	12-bit SAR ADC	LP comparators	TCPWM blocks	SCB blocks	GPIO		28-SSOP	-40 to +85 °C (A grade)
4100	CY8C4124PVA-442Z	24	16	4	-	1	✓	✓	806 Ksps	2	4	2	24	✓	✓	-
	CY8C4125PVA-482Z	24	32	4	-	1	✓	✓	806 Ksps	2	4	2	24	✓	✓	-
	CY8C4124PVS-442Z	24	16	4	-	1	✓	✓	806 Ksps	2	4	2	24	✓	-	✓
	CY8C4125PVS-482Z	24	32	4	-	1	✓	✓	806 Ksps	2	4	2	24	✓	-	✓
	CY8C4125PVA-482	24	32	4	-	1	✓	✓	806 Ksps	2	4	2	24	✓	-	✓

### 8.1 Part numbering conventions

PSoC™ 4 devices follow the part numbering convention described in the following table. All fields are single-character alphanumeric (0, 1, 2, ..., 9, A,B, ..., Z) unless stated otherwise.

The part numbers are of the form CY8C4ABCDEF-GHI where the fields are defined as follows.

## PSoC™ 4: PSoC™ 4100

### 8 Ordering information

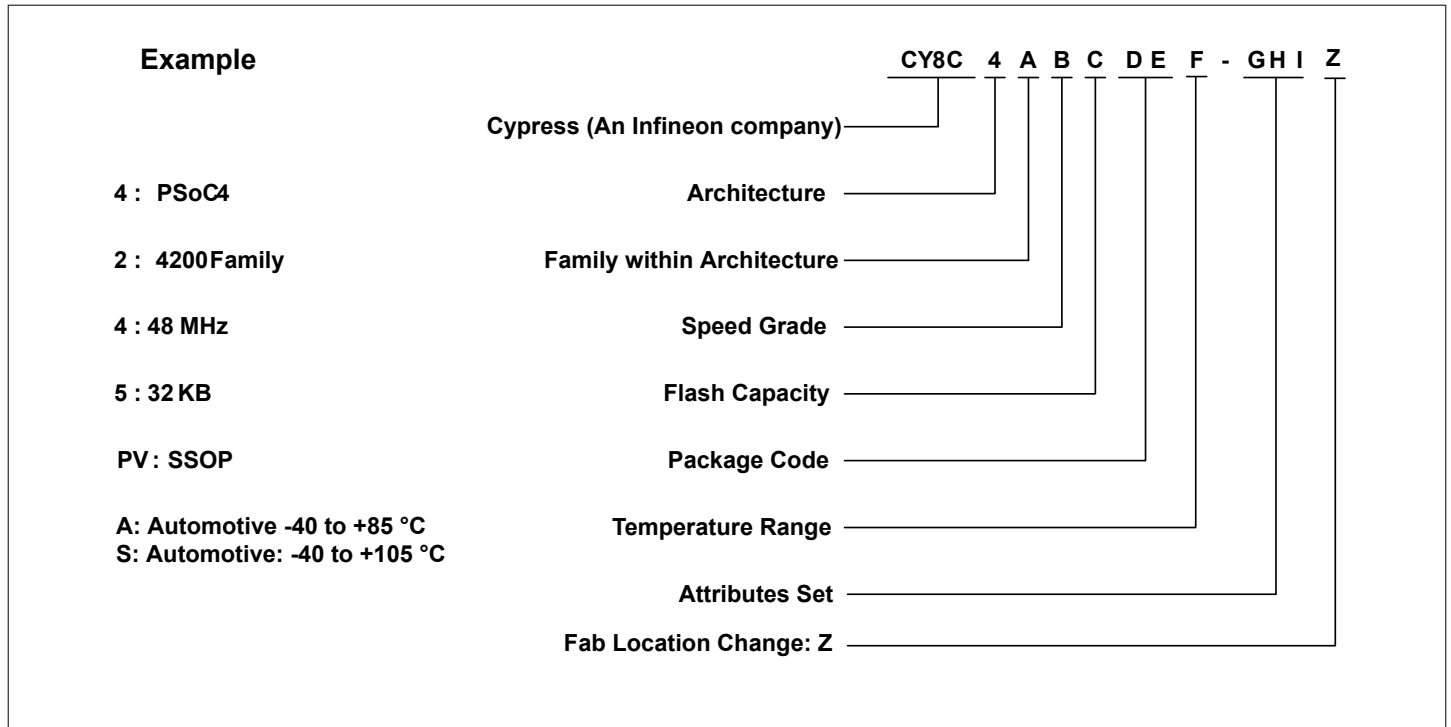

**Figure 7** Part numbering conventions

The field values are listed in the following table.

Field	Description	Values	Meaning
CY8C	Cypress (An Infineon company)		
4	Architecture	4	PSoC™ 4
A	Family within architecture	1	4100 Family
		2	4200 Family
B	CPU speed	2	24 MHz
		4	48 MHz
C	Flash capacity	4	16 KB
		5	32 KB
DE	Package code	PV	SSOP
F	Temperature range	A/S	Automotive
GHI	Attributes code	000-999	Code of feature set in specific family
Z	Fab location change		

## PSoC™ 4: PSoC™ 4100

### 9 Packaging

## 9 Packaging

**Table 38** Package characteristics

Parameter	Description	Conditions	Min	Typ	Max	Units
T <sub>A</sub>	Operating ambient temperature	For A grade devices	-40	25.00	85	°C
T <sub>A</sub>	Operating ambient temperature	For S grade devices	-40	25.00	105	°C
T <sub>J</sub>	Operating junction temperature	For A grade devices	-40	-	100	°C
T <sub>J</sub>	Operating junction temperature	For S grade devices	-40	-	120	°C
T <sub>JA</sub>	Package $\theta_{JA}$ (28-pin SSOP)		-	66.58	-	°C/W
T <sub>JC</sub>	Package $\theta_{JC}$ (28-pin SSOP)		-	46.28	-	°C/W

**Table 39** Solder reflow peak temperature

Package	Maximum peak temperature	Maximum time at peak temperature
28-pin SSOP	260 °C	30 seconds

**Table 40** Package moisture sensitivity level (MSL), IPC/JEDEC J-STD-2

Package	MSL
28-pin SSOP	MSL 3

PSoC™ 4 CAB Libraries with Schematics Symbols and PCB Footprints are on the Infineon [webpage](#)

# PSoC™ 4: PSoC™ 4100

## 9 Packaging

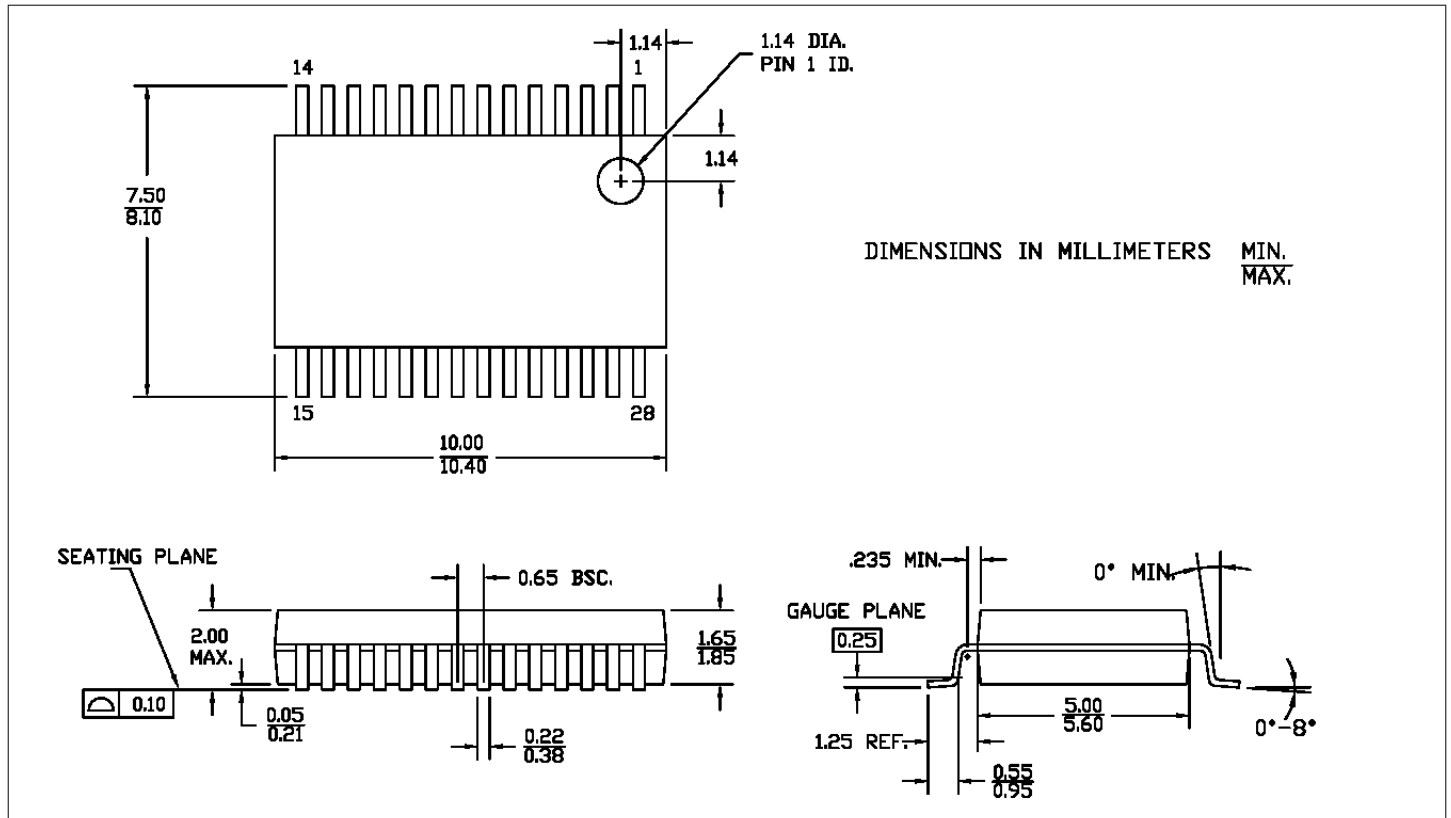

**Figure 8**      **28-pin SSOP (210 Mils) Package Outline, 51-85079 (PG-SSOP-28)**

## PSoC™ 4: PSoC™ 4100

### 10 Acronyms

## 10 Acronyms

**Table 41** Acronyms used in this document

Acronym	Description
abus	analog local bus
ADC	analog-to-digital converter
AG	analog global
AHB	AMBA (advanced microcontroller bus architecture) high-performance bus, an Arm® data transfer bus
ALU	arithmetic logic unit
AMUXBUS	analog multiplexer bus
API	application programming interface
APSR	application program status register
Arm®	advanced RISC machine, a CPU architecture
ATM	automatic thump mode
BW	bandwidth
CAN	Controller Area Network, a communications protocol
CMRR	common-mode rejection ratio
CPU	central processing unit
CRC	cyclic redundancy check, an error-checking protocol
DAC	digital-to-analog converter, see also IDAC, VDAC
DFB	digital filter block
DIO	digital input/output, GPIO with only digital capabilities, no analog. See GPIO.
DMIPS	Dhrystone million instructions per second
DMA	direct memory access, see also TD
DNL	differential nonlinearity, see also INL
DNU	do not use
DR	port write data registers
DSI	digital system interconnect
DWT	data watchpoint and trace
ECC	error correcting code
ECO	external crystal oscillator
EEPROM	electrically erasable programmable read-only memory
EMI	electromagnetic interference
EMIF	external memory interface
EOC	end of conversion

(table continues...)

## PSoC™ 4: PSoC™ 4100

### 10 Acronyms

**Table 41** (continued) Acronyms used in this document

Acronym	Description
EOF	end of frame
EPSR	execution program status register
ESD	electrostatic discharge
ETM	embedded trace macrocell
FIR	finite impulse response, see also IIR
FPB	flash patch and breakpoint
FS	full-speed
GPIO	general-purpose input/output, applies to a PSoC™ pin
HVI	high-voltage interrupt, see also LVI, LVD
IC	integrated circuit
IDAC	current DAC, see also DAC, VDAC
IDE	integrated development environment
I <sup>2</sup> C, or IIC	Inter-Integrated Circuit, a communications protocol
IIR	infinite impulse response, see also FIR
ILO	internal low-speed oscillator, see also IMO
IMO	internal main oscillator, see also ILO
INL	integral nonlinearity, see also DNL
I/O	input/output, see also GPIO, DIO, SIO, USBIO
IPOR	initial power-on reset
IPSR	interrupt program status register
IRQ	interrupt request
ITM	instrumentation trace macrocell
LCD	liquid crystal display
LIN	Local Interconnect Network, a communications protocol.
LR	link register
LUT	lookup table
LVD	low-voltage detect, see also LVI
LVI	low-voltage interrupt, see also HVI
LVTTTL	low-voltage transistor-transistor logic
MAC	multiply-accumulate
MCU	microcontroller unit
MISO	master-in slave-out
NC	no connect

**(table continues...)**

## PSoC™ 4: PSoC™ 4100

### 10 Acronyms

**Table 41** (continued) Acronyms used in this document

Acronym	Description
NMI	nonmaskable interrupt
NRZ	non-return-to-zero
NVIC	nested vectored interrupt controller
NVL	nonvolatile latch, see also WOL
opamp	operational amplifier
PAL	programmable array logic, see also PLD
PC	program counter
PCB	printed circuit board
PGA	programmable gain amplifier
PHUB	peripheral hub
PHY	physical layer
PICU	port interrupt control unit
PLA	programmable logic array
PLD	programmable logic device, see also PAL
PLL	phase-locked loop
PMDD	package material declaration data sheet
POR	power-on reset
PRES	precise power-on reset
PRS	pseudo random sequence
PS	port read data register
PSoC™	Programmable System-on-Chip™
PSRR	power supply rejection ratio
PWM	pulse-width modulator
RAM	random-access memory
RISC	reduced-instruction-set computing
RMS	root-mean-square
RTC	real-time clock
RTL	register transfer language
RTR	remote transmission request
RX	receive
SAR	successive approximation register
SC/CT	switched capacitor/continuous time
SCL	I <sup>2</sup> C serial clock

**(table continues...)**

## PSoC™ 4: PSoC™ 4100

### 10 Acronyms

**Table 41** (continued) Acronyms used in this document

Acronym	Description
SDA	I <sup>2</sup> C serial data
S/H	sample and hold
SINAD	signal to noise and distortion ratio
SIO	special input/output, GPIO with advanced features. See GPIO.
SOC	start of conversion
SOF	start of frame
SPI	Serial Peripheral Interface, a communications protocol
SR	slew rate
SRAM	static random access memory
SRES	software reset
SWD	serial wire debug, a test protocol
SWV	single-wire viewer
TD	transaction descriptor, see also DMA
THD	total harmonic distortion
TIA	transimpedance amplifier
TRM	technical reference manual
TTL	transistor-transistor logic
TX	transmit
UART	Universal Asynchronous Transmitter Receiver, a communications protocol
UDB	universal digital block
USB	Universal Serial Bus
USBIO	USB input/output, PSoC™ pins used to connect to a USB port
VDAC	voltage DAC, see also DAC, IDAC
WDT	watchdog timer
WOL	write once latch, see also NVL
WRES	watchdog timer reset
XRES	external reset I/O pin
XTAL	crystal

## PSoC™ 4: PSoC™ 4100

### 11 Document conventions

## 11 Document conventions

### Units of measure

**Table 42** Units of measure

Symbol	Unit of measure
°C	degrees Celsius
dB	decibel
fF	femtofarad
Hz	hertz
KB	1024 bytes
kbps	kilobits per second
Khr	kilohour
kHz	kilohertz
kΩ	kilo ohm
ksps	kilosamples per second
LSB	least significant bit
Mbps	megabits per second
MHz	megahertz
MΩ	mega-ohm
Msps	megasamples per second
μA	microampere
μF	microfarad
μH	microhenry
μs	microsecond
μV	microvolt
μW	microwatt
mA	milliampere
ms	millisecond
mV	millivolt
nA	nanoampere
ns	nanosecond
nV	nanovolt
Ω	ohm
pF	picofarad
ppm	parts per million
ps	picosecond
s	second
sps	samples per second

**(table continues...)**

**PSoC™ 4: PSoC™ 4100****11 Document conventions**

---

**Table 42 (continued) Units of measure**

<b>Symbol</b>	<b>Unit of measure</b>
sqrtHz	square root of hertz
V	volt

## PSoC™ 4: PSoC™ 4100

---

### 12 References

## 12 References

Worldwide sales and design support

Infineon maintains a worldwide network of offices, solution centers, manufacturer's representatives, and distributors. To find the office closest to you, visit [webpage](#).

Products

[Arm® Cortex® Microcontrollers](#)

[Automotive](#)

[Clocks & Timing Solutions](#)

[Transceivers](#)

[Internet of Things](#)

[Memories](#)

[Microcontroller](#)

[Power Management ICs](#)

[Touch Sensing](#)

[USB Controllers](#)

[Wireless Connectivity](#)

PSoC™ Solutions

[PSoC™ 1](#) | [PSoC™ 3](#) | [PSoC™ 4](#) | [PSoC™ 5LP](#) | [PSoC™ 6 MCU](#)

[Infineon developer community](#)

[Technical support](#)

## PSoC™ 4: PSoC™ 4100

### Revision history

### Revision history

Document revision	Date	Description of changes
**	2014-08-04	New data sheet.
*A	2015-04-29	<p>Changed status from Advance to Preliminary.</p> <p>Updated Functional Overview:</p> <p>Updated Fixed Function Digital:</p> <p>Updated Serial Communication Blocks (SCB):</p> <p>Updated description (Added LIN Slave Mode section).</p> <p>Updated Packaging:</p> <p>Updated Table 45:</p> <p>Added details in “Conditions” column corresponding to <math>T_A</math> and <math>T_J</math> parameters.</p> <p>Added details of <math>T_J</math> parameter corresponding to Condition “For S grade devices”.</p> <p>Removed 40-pin QFN, 44-pin TQFP package related information. spec 51-85079 – Changed revision from *E to *F.</p> <p>Updated to new template.</p>
*B	2016-01-21	<p>Changed status from Preliminary to Final.</p> <p>Updated Pinouts:</p> <p>Updated details in “Name” and “Pin Description” columns corresponding to pin 27.</p> <p>Updated Power:</p> <p>Updated Unregulated External Supply:</p> <p>Updated description.</p> <p>Updated Regulated External Supply:</p> <p>Updated description.</p> <p>Updated details in “Power Supply” column in the table.</p>
*C	2016-01-31	<p>Updated Features:</p> <p>Updated Programmable Analog:</p> <p>Replaced “Two opamps” with “One opamp”.</p> <p>Updated Block Diagram:</p> <p>Replaced “2x” with “1x”.</p> <p>Updated Functional Overview:</p> <p>Updated Analog Blocks:</p> <p>Updated Opamp (CTBm Block):</p> <p>Replaced “Two opamps” with “Opamp” in heading.</p> <p>Updated description.</p> <p>Updated Power:</p> <p>Updated Unregulated External Supply:</p> <p>Updated Table 1:</p> <p>Updated details in “Bypass Capacitors” column corresponding to “VDDD–VSS” and “VCCD–VSS” power supplies.</p>

## PSoC™ 4: PSoC™ 4100

### Revision history

Document revision	Date	Description of changes
*D	2016-07-04	<p>Updated Functional Overview:</p> <p>Updated CPU and Memory Subsystem:</p> <p>Updated Flash:</p> <p>Updated description.</p> <p>Updated Fixed Function Digital:</p> <p>Updated Serial Communication Blocks (SCB):</p> <p>Updated description.</p> <p>Updated Pinouts:</p> <p>Updated description.</p> <p>Updated Figure 3.</p> <p>Updated Power:</p> <p>Added Figure 4.</p> <p>Updated Unregulated External Supply:</p> <p>Updated Table 1:</p> <p>Updated details in “Bypass Capacitors” column corresponding to “VDDD–VSS” and “VREF–VSS (optional)” Power Supply.</p> <p>Updated Electrical Specifications:</p> <p>Updated Device-Level Specifications:</p> <p>Updated Table 3:</p> <p>Updated entire table.</p> <p>Updated Analog Peripherals:</p> <p>Updated Opamp:</p> <p>Updated Table 8:</p> <p>Updated values in “Typ” and “Max” columns for <math>I_{DD\_HI}</math>, <math>I_{DD\_MED}</math>, <math>I_{DD\_LOW}</math> parameters.</p> <p>Updated details in “Details/Conditions” column corresponding to “SID290” Spec ID and “<math>V_{OS\_DR\_TR}</math>” parameter.</p> <p>Added SID290Q Spec ID corresponding to <math>V_{OS\_DR\_TR}</math> parameter and its details.</p> <p>Added SID299A Spec ID corresponding to <math>OL\_GAIN</math> parameter and its details.</p> <p>Updated Comparator:</p> <p>Updated Table 9:</p> <p>Updated details in “Description”, “Min”, “Typ”, “Max” columns corresponding to “<math>I_{CMP1}</math>”, “<math>I_{CMP2}</math>” and “<math>I_{CMP3}</math>” parameters.</p> <p>Updated Table 10:</p> <p>Updated details in “Description”, “Min”, “Typ”, “Max” columns corresponding to “<math>T_{RESP1}</math>”, “<math>T_{RESP2}</math>” and “<math>T_{RESP3}</math>” parameters.</p> <p>Updated Digital Peripherals:</p> <p>Removed “Timer”.</p> <p>Removed “Counter”.</p> <p>Removed “Pulse Width Modulation (PWM)”.</p> <p>Added Timer/Counter/PWM.</p> <p>Updated I2C:</p> <p>Updated Table 16:</p> <p>Changed maximum value of <math>I_{I2C1}</math> parameter from 10.5 <math>\mu A</math> to 50 <math>\mu A</math>.</p> <p>Updated LCD Direct Drive:</p>

## PSoC™ 4: PSoC™ 4100

### Revision history

Document revision	Date	Description of changes
		<p>Updated Table 20:            Changed maximum value of <math>I_{UART1}</math> parameter from 9 <math>\mu</math>A to 55 <math>\mu</math>A.</p> <p>Updated SPI Specifications:            Updated Table 25:            Replaced “FCPU” with “Tscbclk” in “Max” column corresponding to <math>T_{DSO}</math> parameter.</p> <p>Updated Memory:            Updated Table 27:            Added <math>F_{RETQ}</math> parameter and its details.</p> <p>Updated Electrical Specifications:            Updated System Resources:            Updated Power-on-Reset (POR) with Brown Out:            Updated Table 29:            Updated details in “Details/Conditions” column corresponding to <math>V_{FALLPPOR}</math> parameter.</p> <p>Added Svdd parameter and its details.            Updated Internal Main Oscillator:            Updated Table 34:            Updated details in “Details/Conditions” column corresponding to <math>F_{IMOTOL1}</math> parameter.</p> <p>Updated Internal Low-Speed Oscillator:            Updated Table 36:            Updated details in “Details/Conditions” column corresponding to <math>F_{ILOTRIM1}</math> parameter.</p> <p>Updated Packaging:            Updated description.            Updated to new template.            Completing Sunset Review.</p>
*E	2017-03-28	<p>Updated Ordering Information:            Updated part numbers.            Updated to new template.</p>
*F	2017-05-26	<p>No technical updates.            Completing Sunset Review.</p>
*G	2023-11-06	<p>Migrated to IFX template            Updated Ordering Information            Completing Sunset review</p>

## Trademarks

All referenced product or service names and trademarks are the property of their respective owners.

### Edition 2023-11-06

#### Published by

**Infineon Technologies AG**  
81726 Munich, Germany

© 2023 Infineon Technologies AG

All Rights Reserved.

**Do you have a question about any aspect of this document?**

Email: [erratum@infineon.com](mailto:erratum@infineon.com)

#### Document reference

**IFX-qfq1691498721945**

### Important notice

The information contained in this application note is given as a hint for the implementation of the product only and shall in no event be regarded as a description or warranty of a certain functionality, condition or quality of the product. Before implementation of the product, the recipient of this application note must verify any function and other technical information given herein in the real application. Infineon Technologies hereby disclaims any and all warranties and liabilities of any kind (including without limitation warranties of non-infringement of intellectual property rights of any third party) with respect to any and all information given in this application note.

The data contained in this document is exclusively intended for technically trained staff. It is the responsibility of customer's technical departments to evaluate the suitability of the product for the intended application and the completeness of the product information given in this document with respect to such application.

### Warnings

Due to technical requirements products may contain dangerous substances. For information on the types in question please contact your nearest Infineon Technologies office.

Except as otherwise explicitly approved by Infineon Technologies in a written document signed by authorized representatives of Infineon Technologies, Infineon Technologies' products may not be used in any applications where a failure of the product or any consequences of the use thereof can reasonably be expected to result in personal injury.

## OUR CERTIFICATE

DiGi provide top-quality products and perfect service for customer worldwide through standardization, technological innovation and continuous improvement. DiGi through third-party certification, we stricly control the quality of products and services. Welcome your RFQ to

Email: [Info@DiGi-Electronics.com](mailto:Info@DiGi-Electronics.com)



Tel: +00 852-30501935

RFQ Email: [Info@DiGi-Electronics.com](mailto:Info@DiGi-Electronics.com)

DiGi is a global authorized distributor of electronic components.