

# TLT9252VLCXUMA1 Datasheet

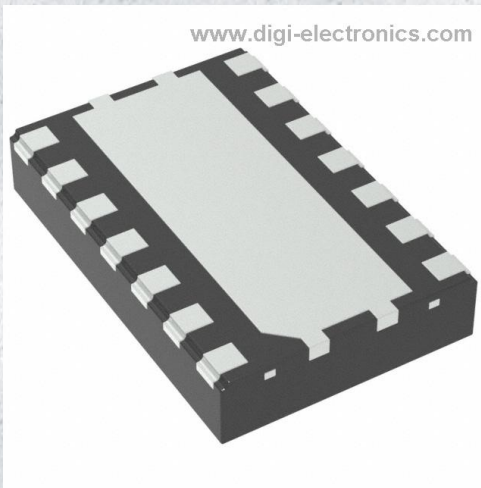

<https://www.DiGi-Electronics.com>

DiGi Electronics Part Number	TLT9252VLCXUMA1-DG
Manufacturer	<a href="#">Infineon Technologies</a>
Manufacturer Product Number	TLT9252VLCXUMA1
Description	IC TRANSCEIVER HALF 1/1 TSON-14
Detailed Description	1/1 Transceiver Half CANbus PG-TSON-14-3



Tel: +00 852-30501935

RFQ Email: [Info@DiGi-Electronics.com](mailto:Info@DiGi-Electronics.com)

DiGi is a global authorized distributor of electronic components.



## Purchase and inquiry

Manufacturer Product Number:

TLT9252VLCXUMA1

Series:

-

Type:

Transceiver

Number of Drivers/Receivers:

1/1

Receiver Hysteresis:

30 mV

Voltage - Supply:

4.5V ~ 5.5V

Grade:

Automotive

Mounting Type:

Surface Mount, Wettable Flank

Supplier Device Package:

PG-TSON-14-3

Manufacturer:

Infineon Technologies

Product Status:

Active

Protocol:

CANbus

Duplex:

Half

Data Rate:

5Mbps

Operating Temperature:

-40°C ~ 150°C (TJ)

Qualification:

AEC-Q100

Package / Case:

14-TDFN Exposed Pad

## Environmental & Export classification

RoHS Status:

ROHS3 Compliant

REACH Status:

REACH Unaffected

Moisture Sensitivity Level (MSL):

2A (4 Weeks)

# TLT9252VLC

## High-Speed CAN FD Transceiver



RoHS



## 1 Overview

### Features

- Fully compliant to ISO 11898-2 (2016) and SAE J2284-4/-5
- Infineon automotive quality
- AEC-Q100 Grade 0 (Ta: -40°C to +150°C) qualification for high temperature mission profiles
- Guaranteed loop delay symmetry to support CAN FD data frames up to 5 MBit/s
- Bus Wake-up Pattern (WUP) function with optimized filter time (0.5µs - 1.8µs) for worldwide OEM usage
- Excellent ESD robustness +/-10kV (HBM) and +/-9kV (IEC 61000-4-2)
- Very low current consumption in Sleep Mode of max. 25µA
- Extended supply range on  $V_{CC}$  and  $V_{IO}$  supply
- Dual Power Supply Solution via  $V_{BAT}$  and  $V_{CC}$  for robust behavior during battery cranking
- Fail safe features like TxD time-out, RxD Recessive Clamping and Overtemperature shut-down
- Very low electromagnetic emission (EME) for chokeless usage
- Wide common mode range for electromagnetic immunity (EMI)
- CAN short circuit proof to ground, battery and  $V_{CC}$
- Undervoltage detection on  $V_{BAT}$ ,  $V_{CC}$  and  $V_{IO}$
- Autonomous bus biasing according to ISO 11898-2 (2016)
- Bus Wake-up (WUP) and Local Wake-Up (LWU)
- INH output to control external circuitry
- Improved robust local failure diagnosis via NERR output pin
- Green Product (RoHS compliant)

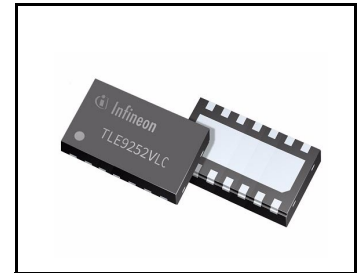

### Potential Applications

- Car powertrain and transmission applications
- Infotainment applications
- Cluster Modules
- Radar applications
- HVAC



## TLT9252VLC

### High-Speed CAN FD Transceiver

---

#### Overview

### Product validation

Qualified for automotive applications with higher temperature requirements as well as with extended lifetime requirements. Product validation according to AEC-Q100.

### Description

The TLT9252VLC is a transceiver designed for HS CAN networks up to 5 Mbit/s in automotive and industrial applications. As an interface between the physical bus layer and the CAN protocol controller, the TLT9252VLC drives the signals to the bus and protects the microcontroller against interferences generated within the network. Based on the high symmetry of the CANH and CANL signals, the TLT9252VLC provides very low electromagnetic emission allowing the operation without a common mode choke. The non-low power modes (Normal-operating Mode and Receive-only Mode) and low power modes (Sleep Mode and Stand-by Mode) are optimized for reduced current consumption based on the required functionality. Even in Sleep Mode with a quiescent current below 25  $\mu\text{A}$  over the full temperature range, the TLT9252VLC is able to detect a Wake-Up Pattern (WUP) on the HS CAN bus. The  $V_{IO}$  voltage reference input is used to support 3.3 V and 5 V supplied microcontrollers. The TLT9252VLC is integrated in an RoHS compliant PG-TSON-14 package and fulfills the requirements of the ISO11898-2 (2016).

Type	Package	Marking
TLT9252VLC	PG-TSON-14	T9252V

# TLT9252VLC

## High-Speed CAN FD Transceiver

### Table of contents

<b>1</b>	<b>Overview</b> .....	<b>1</b>
	<b>Features</b> .....	<b>1</b>
	<b>Potential Applications</b> .....	<b>1</b>
	<b>Product validation</b> .....	<b>2</b>
	<b>Description</b> .....	<b>2</b>
	<b>Table of contents</b> .....	<b>3</b>
<b>2</b>	<b>Block diagram</b> .....	<b>5</b>
<b>3</b>	<b>Pin configuration</b> .....	<b>6</b>
3.1	Pin assignment .....	6
3.2	Pin definitions .....	6
<b>4</b>	<b>General product characteristics</b> .....	<b>8</b>
4.1	Absolute maximum ratings .....	8
4.2	Functional range .....	9
4.3	Thermal resistance .....	9
<b>5</b>	<b>High-Speed CAN functional description</b> .....	<b>10</b>
<b>6</b>	<b>Modes of operation</b> .....	<b>12</b>
6.1	Normal-operating Mode .....	14
6.2	Receive-only Mode .....	15
6.3	Stand-by Mode .....	16
6.4	Go-to-Sleep command .....	17
6.5	Sleep Mode .....	18
6.5.1	Mode change to Sleep Mode or Stand-by Mode .....	18
6.5.2	Mode Change via EN and NSTB pin .....	20
6.6	Power On Reset .....	21
6.7	Autonomous bus voltage biasing .....	22
6.8	Wake-Up functions .....	23
6.8.1	Wake-up Pattern (WUP) .....	23
6.8.2	Local Wake-Up (LWU) .....	24
6.9	Wake-up: RxD and NERR behavior .....	25
<b>7</b>	<b>Fail safe functions</b> .....	<b>27</b>
7.1	Short Circuit Protection .....	27
7.2	Undervoltage detection .....	27
7.2.1	Undervoltage and power-down detection on $V_{BAT}$ .....	27
7.2.2	Undervoltage detection on $V_{CC}$ .....	28
7.2.3	Undervoltage detection on $V_{IO}$ .....	29
7.3	Dual Power Supply Solution .....	30
7.4	Unconnected logic pins .....	30
7.5	TxD time-out function .....	30
7.6	Overtemperature protection .....	31
7.7	RxD Recessive Clamping detection .....	31
7.8	Delay time for mode change .....	32
<b>8</b>	<b>Diagnosis-flags at NERR and RxD</b> .....	<b>33</b>



# TLT9252VLC

## High-Speed CAN FD Transceiver

---

<b>9</b>	<b>Electrical characteristics</b>	<b>35</b>
9.1	General timing parameter	35
9.2	Power supply interface	35
9.2.1	Current consumptions	35
9.2.2	Undervoltage detection	36
9.2.3	INH output	37
9.3	EN, NSTB and NERR	38
9.4	CAN controller interface	38
9.5	Transmitter	39
9.6	Receiver	40
9.7	Dynamic transceiver parameter	42
9.8	Wake-up	44
9.8.1	General wake-up timings	44
9.8.2	WUP detection characteristics	45
9.8.3	Local Wake-Up	45
<b>10</b>	<b>Application information</b>	<b>46</b>
10.1	ESD robustness according to IEC61000-4-2	46
10.2	Voltage adaption to the microcontroller supply	46
10.3	Application example	47
10.4	Further application information	47
<b>11</b>	<b>Package outline</b>	<b>48</b>
<b>12</b>	<b>Revision history</b>	<b>49</b>

# TLT9252VLC

## High-Speed CAN FD Transceiver

### Block diagram

## 2 Block diagram

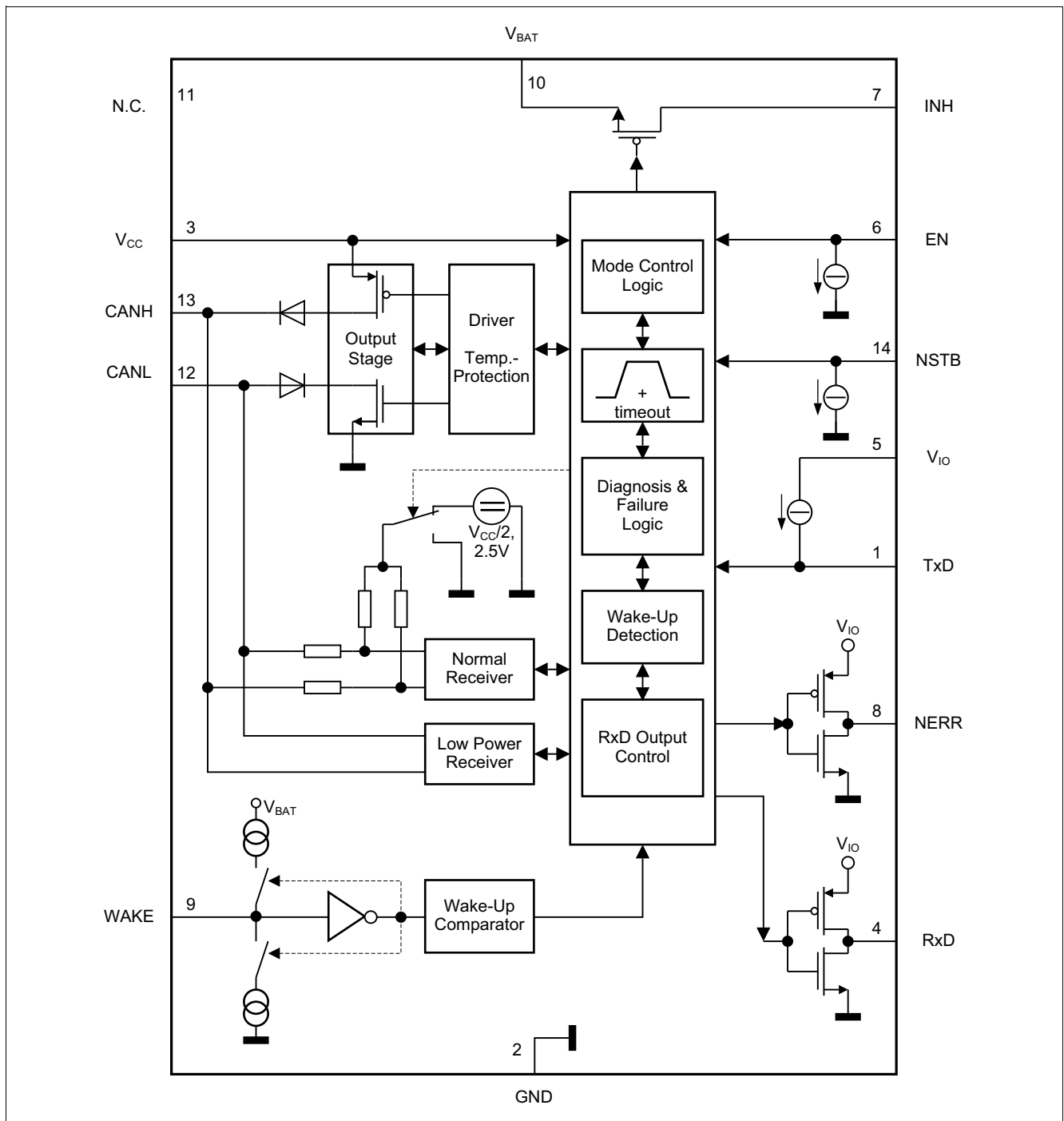

Figure 1 Block diagram

# TLT9252VLC

## High-Speed CAN FD Transceiver

### Pin configuration

## 3 Pin configuration

### 3.1 Pin assignment

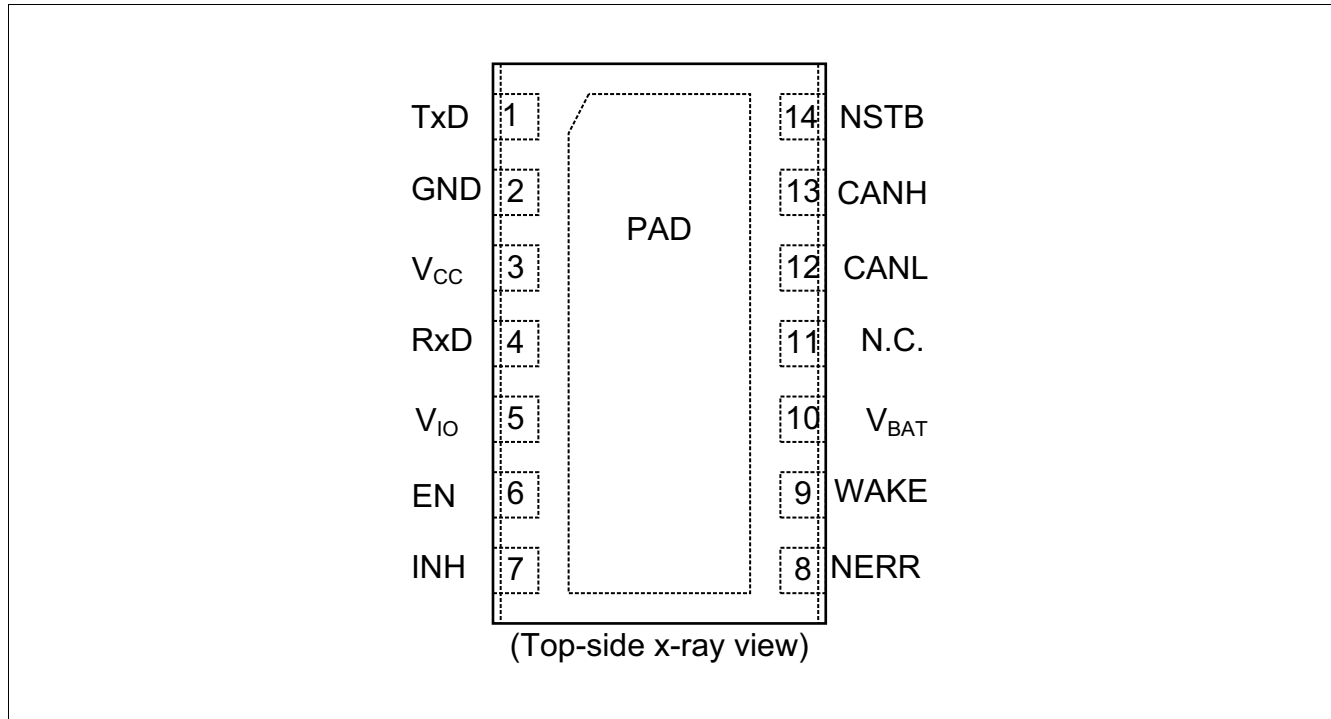

Figure 2 Pin configuration

### 3.2 Pin definitions

Table 1 Pin definitions and functions

Pin	Symbol	Function
1	TxD	<b>Transmit Data input</b> Integrated “pull-up” current source to $V_{IO}$ ; Logical “low” to drive a dominant signal on CANH and CANL.
2	GND	<b>Ground</b>
3	$V_{CC}$	<b>Transmitter supply voltage</b> 100 nF decoupling capacitor to GND recommended.
4	RxD	<b>Receive Data output</b> Logical “low” while a dominant signal is on the HS CAN bus; Output voltage adapted to the voltage on the $V_{IO}$ level shift input.
5	$V_{IO}$	<b>Level shift input</b> Reference voltage for the digital input and output pins; 100 nF decoupling capacitor to GND recommended.
6	EN	<b>Mode control input</b> Integrated “pull-down” current source to GND; Logical “high” for Normal-operating Mode.





## TLT9252VLC

### High-Speed CAN FD Transceiver

#### Pin configuration

**Table 1** Pin definitions and functions (cont'd)

Pin	Symbol	Function
7	INH	<b>Inhibit output</b> Open drain output to control external circuitry; High impedance in Sleep Mode.
8	NERR	<b>Error flag output</b> Failure and wake-up indication output; Active “low”.
9	WAKE	<b>Wake-up input</b> Local wake-up input, terminated against GND and $V_{BAT}$ ; Wake-up input sensitive on rising and falling edge.
10	$V_{BAT}$	<b>Battery supply voltage</b> 100 nF decoupling capacitor to GND recommended.
11	N.C.	<b>Not connected</b>
12	CANL	<b>Low-level HS CAN bus line</b>
13	CANH	<b>High-level HS CAN bus line</b>
14	NSTB	<b>Stand-by control input</b> Integrated “pull-down” current source to GND; Logical “high” for Normal-operating Mode.

# TLT9252VLC

## High-Speed CAN FD Transceiver

### General product characteristics

## 4 General product characteristics

### 4.1 Absolute maximum ratings

**Table 2 Absolute maximum ratings<sup>1)</sup>**

All voltages with respect to ground, positive current flowing into pin (unless otherwise specified)

Parameter	Symbol	Values			Unit	Note or Test Condition	Number
		Min.	Typ.	Max.			
<b>Voltages</b>							
Battery supply voltage	$V_{BAT}$	-0.3	–	40	V	–	P_8.1.1
Transmitter supply voltage	$V_{CC}$	-0.3	–	6.0	V	–	P_8.1.2
Digital voltage reference	$V_{IO}$	-0.3	–	6.0	V	–	P_8.1.3
CANH DC voltage versus GND	$V_{CANH}$	-40	–	40	V	–	P_8.1.4
CANL DC voltage versus GND	$V_{CANL}$	-40	–	40	V	–	P_8.1.5
Differential voltage between CANH and CANL	$V_{CAN\_DIFF}$	-40	–	40	V	–	P_8.1.6
Voltages at pin WAKE	$V_{WAKE}$	-27	–	40	V	–	P_8.1.7
Voltages at pin INH	$V_{INH}$	-0.3	–	$V_{BAT} + 0.3$	V	–	P_8.1.8
Voltages at digital I/O pins: EN, NSTB, TxD, RxD, NERR	$V_{MAX\_IO1}$	-0.3	–	6.0	V	–	P_8.1.9
Voltages at digital I/O pins: EN, NSTB, TxD, RxD, NERR	$V_{MAX\_IO2}$	-0.3	–	$V_{IO} + 0.3$	V	–	P_8.1.10
<b>Currents</b>							
Max. output current on INH	$I_{INH\_Max}$	-5	–	–	mA	–	P_8.1.11
Max. output current on NERR and RxD	$I_{Out\_Max}$	-5	–	5	mA	–	P_8.1.12
<b>Temperatures</b>							
Junction temperature	$T_j$	-40	–	160	°C	–	P_8.1.13
Storage temperature	$T_{stg}$	-55	–	150	°C	–	P_8.1.14
<b>ESD resistivity</b>							
ESD immunity at CANH, CANL, WAKE and $V_{BAT}$ versus to GND	$V_{ESD\_HBM\_CAN}$	-10	–	10	kV	HBM <sup>2)</sup>	P_8.1.15
ESD immunity at all other pins	$V_{ESD\_HBM}$	-2	–	2	kV	HBM <sup>2)</sup>	P_8.1.16
ESD immunity at corner pins	$V_{ESD\_CDM\_CP}$	-750	–	750	V	CDM <sup>3)</sup>	P_8.1.17
ESD immunity at any pin	$V_{ESD\_CDM\_OP}$	-500	–	500	V	CDM <sup>3)</sup>	P_8.1.18

1) Not subject to production test, specified by design.

2) ESD susceptibility, Human Body Model “HBM” according to ANSI/ESDA/JEDEC JS001 (1.5k  $\Omega$ , 100 pF.)

3) ESD susceptibility, Charged Device Model “CDM” according to EIA/JESD22-C101 or ESDA STM 5.3.1.

# TLT9252VLC

## High-Speed CAN FD Transceiver

### General product characteristics

#### Notes

1. Stresses above the ones listed here may cause permanent damage to the device. Exposure to absolute maximum rating conditions for extended periods may affect device reliability.
2. Integrated protection functions are designed to prevent IC destruction under fault conditions described in the data sheet. Fault conditions are considered as “outside” normal operating range. Protection functions are not designed for continuous repetitive operation.

## 4.2 Functional range

**Table 3 Functional range**

Parameter	Symbol	Values			Unit	Note or Test Condition	Number
		Min.	Typ.	Max.			
<b>Supply voltages</b>							
Battery supply voltage	$V_{BAT}$	5.5	–	40	V	–	P_8.2.1
Transmitter supply voltage	$V_{CC}$	4.5	–	5.5	V	–	P_8.2.2
Digital voltage reference	$V_{IO}$	3.0	–	5.5	V	–	P_8.2.3
<b>Thermal parameters</b>							
Junction temperature	$T_j$	-40	–	150	°C	–	P_8.2.4

Note: Within the functional or operating range, the IC operates as described in the circuit description. The electrical characteristics are specified within the conditions given in the Electrical Characteristics table.

## 4.3 Thermal resistance

Note: This thermal data was generated according to JEDEC JESD51 standards. Please visit [www.jedec.org](http://www.jedec.org).

**Table 4 Thermal resistance**

Parameter	Symbol	Values			Unit	Note or Test Condition	Number
		Min.	Typ.	Max.			
<b>Thermal resistance</b>							
Junction to ambient	$R_{thJA\_TSON14}$	–	51	–	K/W	<sup>1)2)</sup> Exposed Pad soldered to PCB	P_8.3.2
<b>Thermal shut-down junction temperature</b>							
Thermal shut-down temperature	$T_{JSD}$	170	180	190	°C	<sup>1)</sup> –	P_8.3.3
Thermal shut-down hysteresis	$\Delta T$	5	10	20	K	<sup>1)</sup> –	P_8.3.4

- 1) Not subject to production test, specified by design.
- 2) Specified  $R_{thJA}$  value is according to Jedec JESD51-2,-7 at natural convection on FR4 2s2p board; The Product (Chip+Package) was simulated on a 76.2 × 114.3 × 1.5 mm board with 2 inner copper layers (2 × 70 mm Cu, 2 × 35 mm Cu).

## TLT9252VLC

### High-Speed CAN FD Transceiver

#### High-Speed CAN functional description

## 5 High-Speed CAN functional description

HS CAN is a serial bus system which connects microcontrollers, sensors and actuators for real-time control applications. The use of the Controller Area Network (abbreviated CAN) within road vehicles is described by the international standard ISO 11898. According to the 7-layer OSI reference model the physical layer of a HS CAN bus system specifies the data transmission from one CAN node to all other available CAN nodes within the network. The physical layer specification of a CAN bus system includes all electrical specifications of a CAN network. The CAN transceiver is part of the physical layer specification. The TLT9252VLC supports both Bus Wake-up Pattern (WUP) functionality and Local Wake-up as defined by the ISO 11898 Standard. Additionally, the TLT9252VLC supports CAN Flexible data rate (CAN FD) transmission up to 5 Mbit/s.

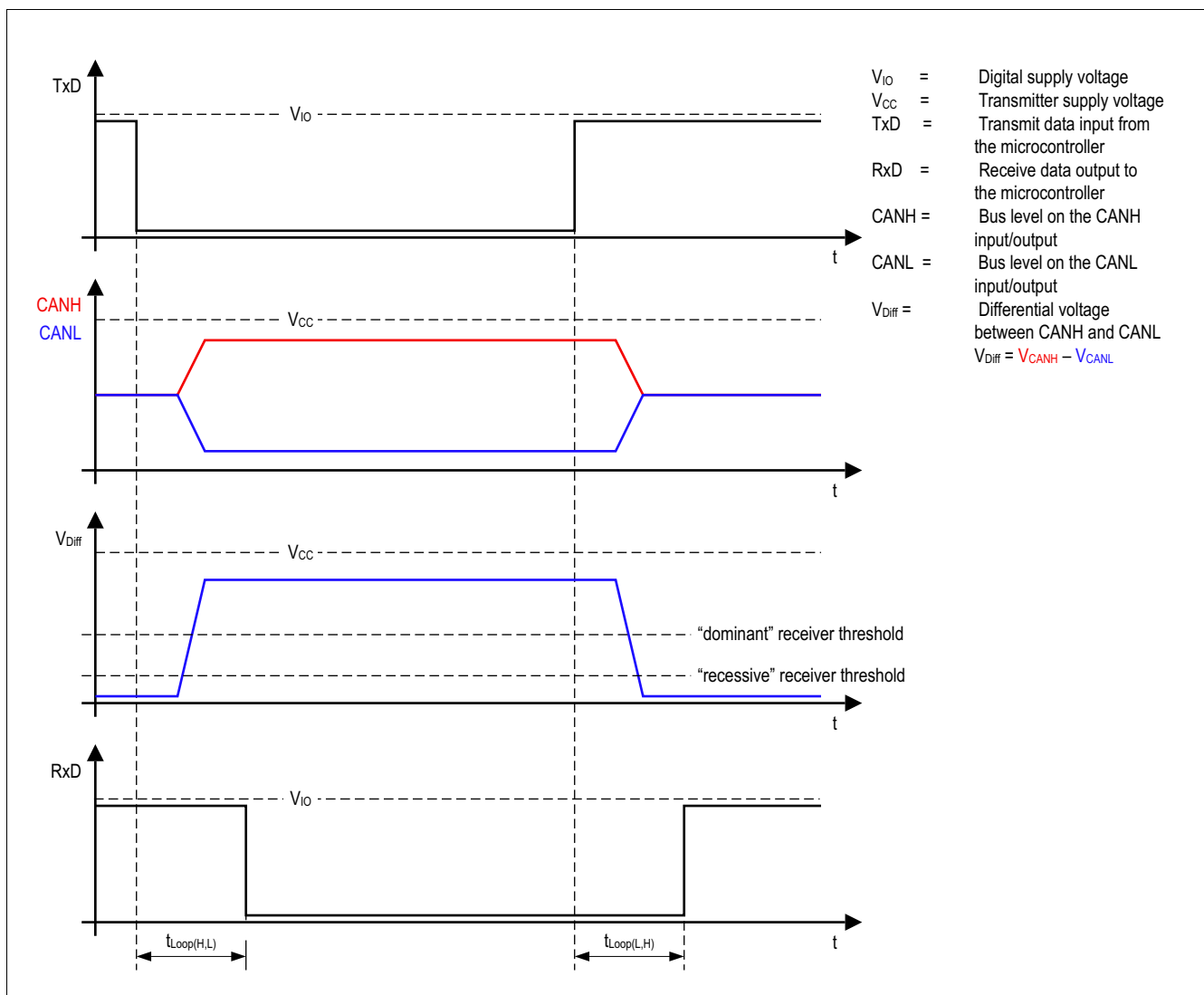

**Figure 3 High-Speed CAN bus signals and logic signals**



## TLT9252VLC

### High-Speed CAN FD Transceiver

#### High-Speed CAN functional description

The TLT9252VLC is a High-Speed CAN transceiver operating as an interface between the CAN controller and the physical bus medium. A HS CAN network is a two wire, differential network which allows data transmission rates up to 5 MBit/s. The characteristic for a HS CAN network are the two signal states on the CAN bus: dominant and recessive (see [Figure 3](#)). The CANH and CANL pins are the interface to the CAN bus and operate as an input and output. The RxD and TxD pins are the interface to the microcontroller. The TxD pin is the serial data input from the CAN controller. The RxD pin is the serial data output to the CAN controller.

The HS CAN transceiver TLT9252VLC includes a receiver and a transmitter unit, allowing the transceiver to send data to the bus medium and monitors the data from the bus medium at the same time. The HS CAN transceiver TLT9252VLC converts the serial data stream which is available on the transmit data input TxD, into a differential output signal on the CAN bus, provided by the CANH and CANL pins. The receiver stage of the TLT9252VLC monitors the data on the CAN bus and converts it to a serial, single-ended signal on the RxD output pin. A logical “low” signal on the TxD pin creates a dominant signal on the CAN bus, followed by a logical “low” signal on the RxD pin (see [Figure 3](#)). The feature, broadcasting data to the CAN bus and listening to the data traffic on the CAN bus simultaneously is essential to support the bit-to-bit arbitration within CAN networks.

The voltage levels for HS CAN transceivers are defined in ISO 11898-2. Whether a data bit is dominant or recessive depends on the voltage difference between the CANH and CANL pins:

$$V_{\text{Diff}} = V_{\text{CANH}} - V_{\text{CANL}}$$

To transmit a dominant signal to the CAN bus the amplitude of the differential signal  $V_{\text{Diff}}$  is higher than or equal to 1.5 V. To receive a recessive signal from the CAN bus the amplitude of the differential  $V_{\text{Diff}}$  is lower than or equal to 0.5 V.

In partially supplied CAN networks, participants have different power supply status. Some nodes are powered, other nodes are unpowered, or some other nodes are in Low-Power Mode. Therefore the TLT9252VLC provides the Sleep Mode in which the device is still able to recognize a Wake-Up Pattern or a local wake-up and signals the wake-up event to the external microcontroller via RxD and NERR output pin. The INH output pin allows to control an external device e.g. a voltage regulator. The HS CAN transceiver TLT9252VLC provides two Low-Power Modes Sleep Mode and Stand-by Mode with optimized very low current consumption.

The voltage level on the digital input TxD and the digital output RxD is determined by the reference supply level at the  $V_{\text{IO}}$  pin. Depending on the voltage level at the  $V_{\text{IO}}$  pin, the signal levels on the logic pins (EN, NERR, NSTB, TxD and RxD) are compatible with microcontrollers having a 5 V or 3.3 V I/O supply. Usually the digital power supply  $V_{\text{IO}}$  of the transceiver is connected to the I/O power supply of the microcontroller.



# TLT9252VLC

## High-Speed CAN FD Transceiver

### Modes of operation

## 6 Modes of operation

The TLT9252VLC supports five different Modes of operation (see **Figure 4**). Each mode with specific characteristics in terms of quiescent current, data transmission or failure diagnostic. For the mode selection the digital input pins EN and NSTB are used. Both digital input pins are event triggered. A mode change via the mode selection pins EN and NSTB is only possible if the power supply voltages  $V_{BAT}$  OR  $V_{CC}$  AND the digital reference voltage  $V_{IO}$  is in the functional range.

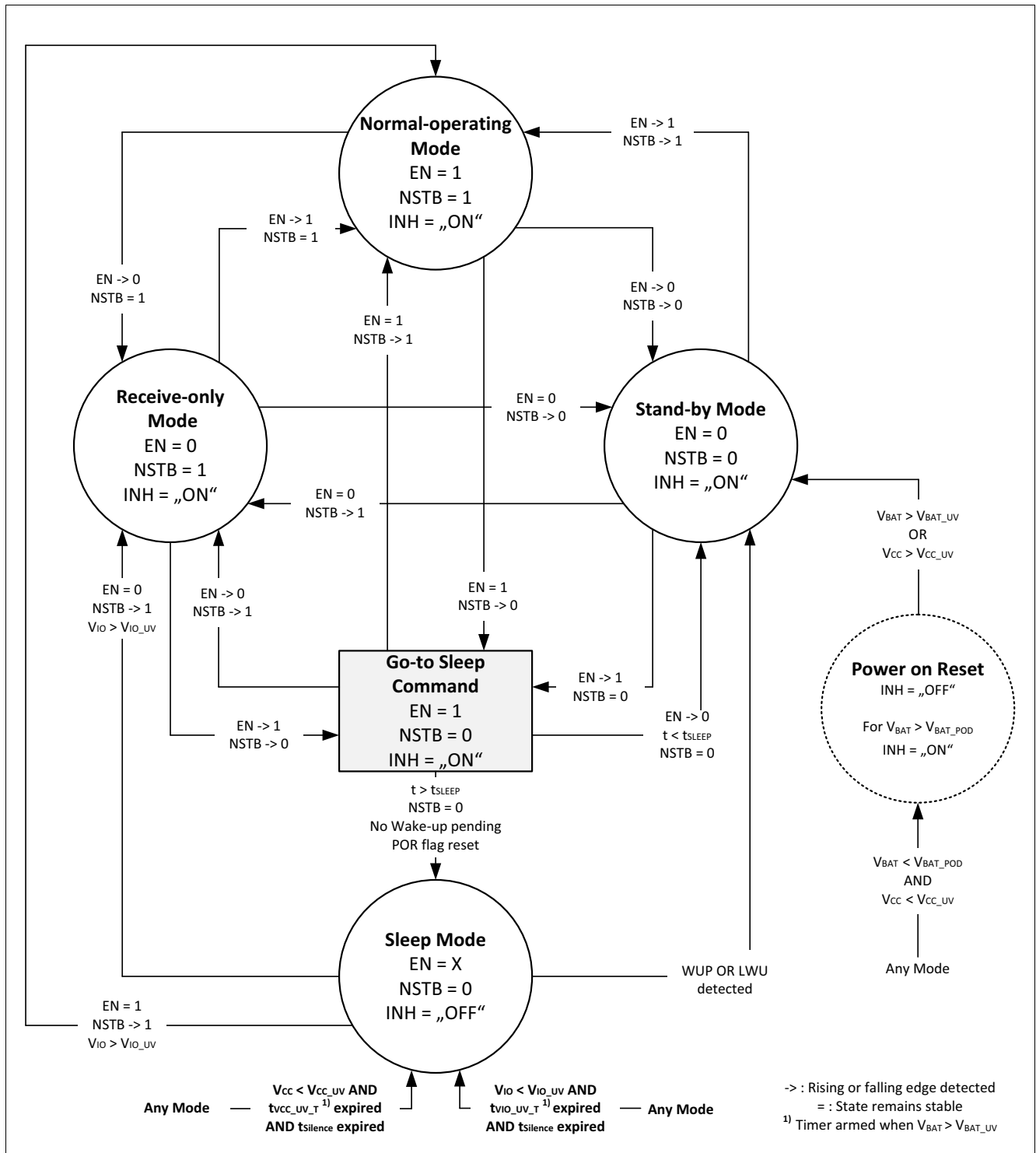

**Figure 4** Modes of operation



## TLT9252VLC

### High-Speed CAN FD Transceiver

#### Modes of operation

The following operation modes are available on the TLT9252VLC:

- Normal-operating Mode ([Chapter 6.1](#))
- Receive-only Mode ([Chapter 6.2](#))
- Stand-by Mode ([Chapter 6.3](#))
- Sleep Mode ([Chapter 6.5](#))
- Go-to-Sleep command ([Chapter 6.4](#))

Depending on the mode, the output driver stage, the receiver stage and the bus biasing are active or inactive. [Table 5](#) shows the different operation modes depending on the logic signal on the input pins EN and NSTB with the related status of the INH pin and the bus biasing.

**Table 5 Overview operation modes**

Operation mode	EN	NSTB	INH	Bus biasing
Normal-operating Mode	1	1	$V_{BAT}$	$V_{CC}/2$
Receive-only Mode	0	1	$V_{BAT}$	$V_{CC}/2$
Stand-by Mode	0	0	$V_{BAT}$	GND <sup>1)</sup>
Go-to-Sleep command	1	0	$V_{BAT}$ <sup>2)</sup>	GND <sup>1)</sup>
Sleep Mode	0	0	High-Z	GND <sup>1)</sup>
Power On Reset	0	0	follows $V_{BAT}$	Floating

1) Valid if  $t_{Silence}$  has expired. The Bus biasing follows the Autonomous Bus Biasing described in [Chapter 6.7](#).

2) INH stays connected to  $V_{BAT}$  as long as  $t_{SLEEP}$  has not expired OR if a wake-up is pending OR if the POR flag is set. If  $t_{SLEEP}$  expires AND no Wake-up is pending AND the POR flag is reset the INH is High Z.

## TLT9252VLC

### High-Speed CAN FD Transceiver

#### Modes of operation

### 6.1 Normal-operating Mode

In Normal-operating Mode all functions of the TLT9252VLC are available and the device is fully functional. Data can be received from the HS CAN bus as well as transmitted to the HS CAN bus.

- The transmitter is active and drives data stream on the TxD input pin to the bus pins CANH and CANL.
- The receiver is active and converts the signals from the bus to a serial data stream on the RxD output pin.
- The bus biasing is connected to  $V_{CC}/2$ .
- The TxD time-out function is enabled (see [Chapter 7.5](#)).
- The overtemperature protection is enabled (see [Chapter 7.6](#)).
- The RxD Recessive Clamping detection is enabled (see [Chapter 7.7](#)).
- The undervoltage detection on  $V_{BAT}$ ,  $V_{CC}$  and  $V_{IO}$  are enabled (see [Chapter 7.2](#)).
- The Local Wake-Up pin is disabled.
- The INH output pin is connected to  $V_{BAT}$ .
- Local failure detection is active and failures are indicated at the NERR output pin (see [Chapter 8](#)).

The TLT9252VLC enters Normal-operating Mode by setting the mode selection pins EN and NSTB to logical “high” (see [Figure 4](#) and [Table 5](#)). Normal-operating Mode can be entered if  $V_{BAT}$  or  $V_{CC}$  is in the functional range and the reference voltage  $V_{IO}$  is in the functional range.

Possible mode changes are described in [Figure 5](#).

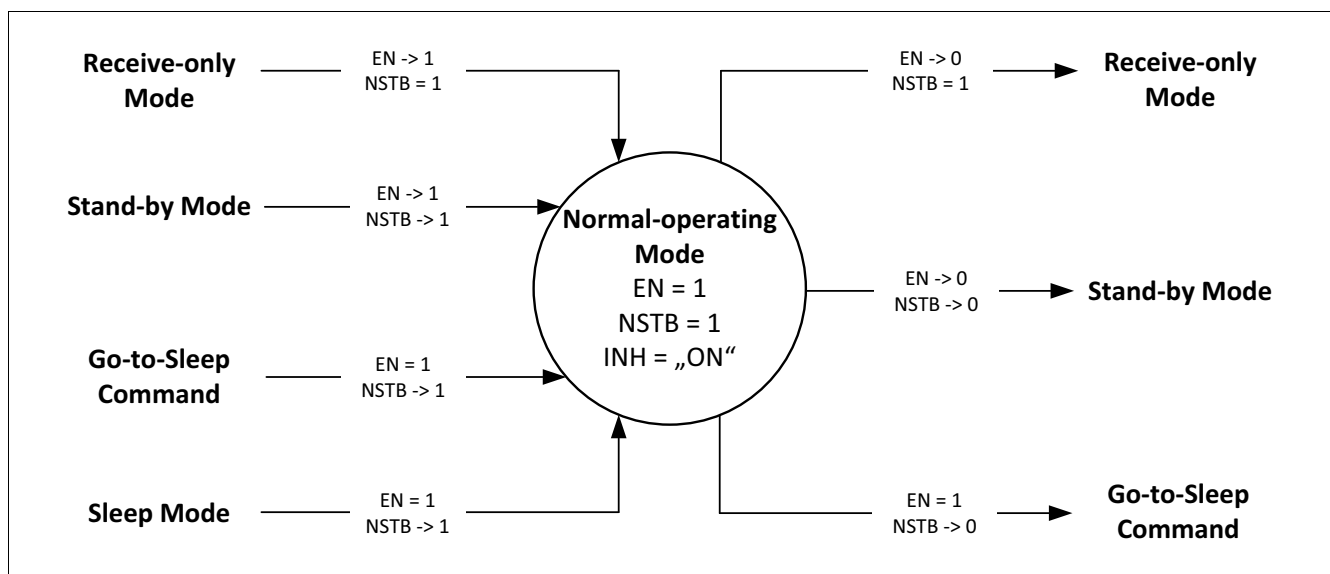

**Figure 5** Mode changes in Normal-operating Mode

## TLT9252VLC

### High-Speed CAN FD Transceiver

#### Modes of operation

### 6.2 Receive-only Mode

In Receive-only Mode the transmitter is disabled and the receiver is enabled. The TLT9252VLC can receive data from the HS CAN bus, but cannot transmit data to the HS CAN bus.

- The transmitter is disabled and the data available on the TxD input is blocked.
- The receiver is active and converts the signals from the bus to a serial data stream on the RxD output pin.
- The bus biasing is connected to  $V_{CC}/2$ .
- The TxD time-out function is disabled.
- The RxD Recessive Clamping detection is disabled.
- The overtemperature protection is disabled.
- The undervoltage detection on  $V_{BAT}$ ,  $V_{CC}$  and  $V_{IO}$  is enabled (see [Chapter 7.2](#)).
- The INH output pin is connected to  $V_{BAT}$ .
- The Local Wake-Up pin is disabled.
- The Power-up flag is signalled at the pin NERR when coming from Standby, Sleep or Go-to-Sleep Command mode.
- The  $V_{CC}$  undervoltage detection is active and an undervoltage is indicated at the NERR output pin when coming from Normal-operating Mode (see [Chapter 8](#)).

Conditions for Entering Receive-only Mode:

The TLT9252VLC enters Receive-only Mode by setting the mode selection pin EN to logical “low” and the NSTB to logical “high” (see [Figure 4](#) and [Table 5](#)). Receive-only Mode can only be entered if  $V_{BAT}$  or  $V_{CC}$  is in the functional range and the reference voltage  $V_{IO}$  is in the functional range.

Possible mode changes are described in [Figure 6](#).

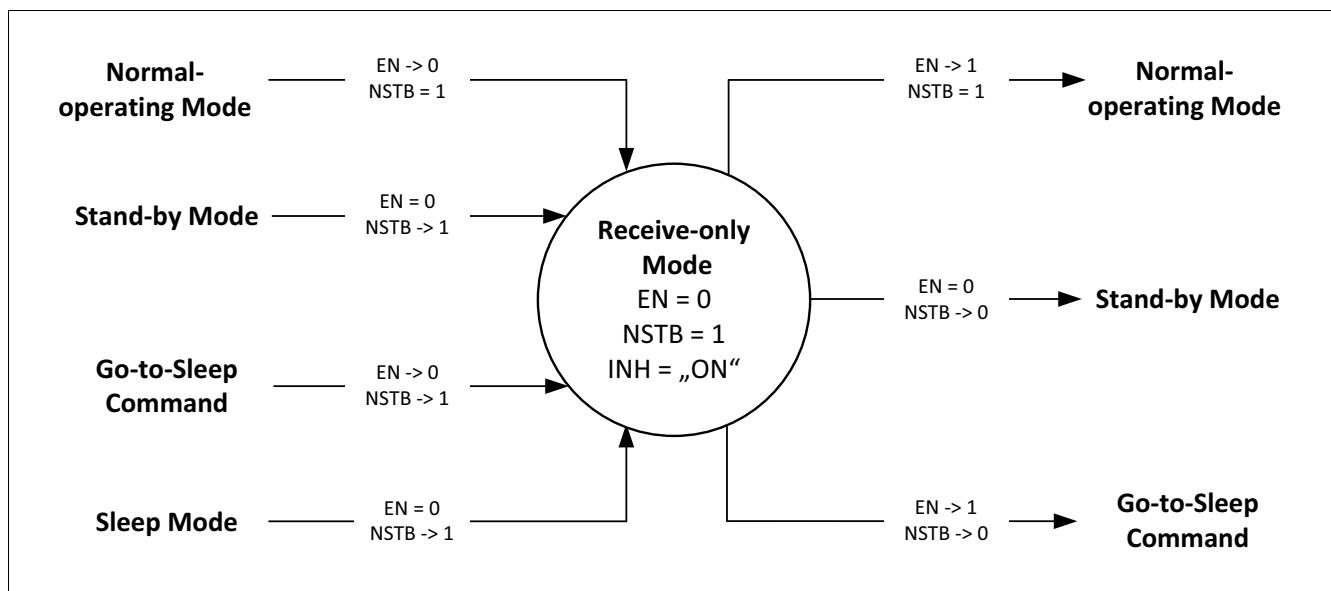

**Figure 6** Mode changes in Receive-only Mode

## TLT9252VLC

### High-Speed CAN FD Transceiver

#### Modes of operation

### 6.3 Stand-by Mode

Stand-by Mode is a low power mode of the TLT9252VLC and the transmitter and the receiver are disabled. In Stand-by Mode the transceiver can neither send data to the HS CAN bus nor receive data from the HS CAN bus:

- The transmitter is disabled and the data available on the TxD input is blocked.
- The low power receiver is enabled and monitors the HS CAN bus for a valid Wake-Up Pattern. The RxD output pin and NERR display a wake-up event ([Chapter 6.9](#)). After Power On Reset RxD and NERR output pins are logical “high”. The default value of the RxD and NERR output pins are logical “high” if no wake-up event is pending.
- The Local Wake-Up (LWU) pin is active.
- After Power On Reset the bus biasing connected to GND. The conditions for the bus biasing are defined in [Chapter 6.7](#).
- TxD Dominant time-out function is disabled.
- RxD Recessive Clamping detection is disabled.
- The overtemperature protection is disabled.
- The undervoltage detection on  $V_{BAT}$ ,  $V_{CC}$  and  $V_{IO}$  is enabled (see [Chapter 7.2](#)).
- The INH output pin is connected to  $V_{BAT}$ .
- Local failure detection on NERR pin is disabled.

Conditions for entering the Stand-by Mode:

- After Power On Reset if  $V_{BAT}$  or  $V_{CC}$  is in the functional range for at least  $t_{PON}$  the TLT9252VLC will enter Stand-by Mode. Mode changes by host command are only possible if  $V_{IO}$  is in the functional range.
- Stand-by Mode will be entered if a wake-up (WUP or LWU) has been detected in Sleep Mode or Go-to-Sleep command.
- The device is in Go-to-Sleep command and the EN pin goes logical “low” before the time  $t < t_{SLEEP}$  has expired.
- The device is in Normal-operating Mode or Receive-only Mode and the input pins EN and NSTB are set to logical “low”.

Possible mode changes are described in [Figure 7](#).

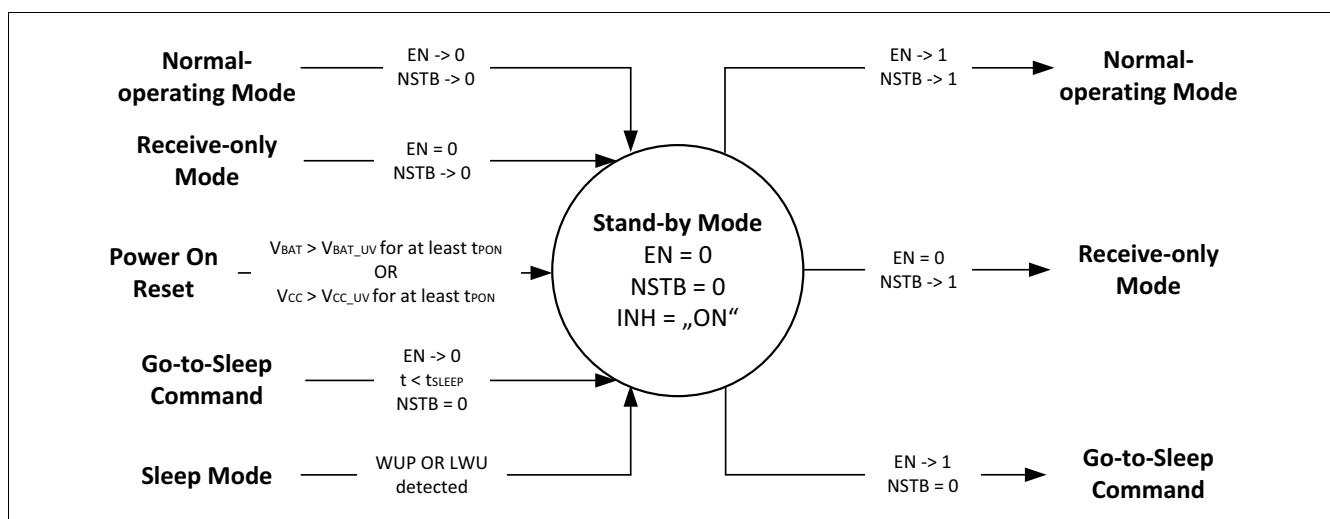

**Figure 7** Mode changes in Stand-by Mode



## TLT9252VLC

### High-Speed CAN FD Transceiver

#### Modes of operation

#### 6.4 Go-to-Sleep command

Go-to-Sleep command is a transition mode allowing external circuitry like a microcontroller to prepare the ECU to go to Sleep Mode. The TLT9252VLC stays for the maximum time  $t = t_{\text{SLEEP}}$  in Go-to-Sleep command. After exceeding the time  $t_{\text{SLEEP}}$  the device changes to Sleep Mode if no wake-up is pending AND the POR flag has been reset. If a wake-up is pending OR the POR flag is set the device remains in Go-to-Sleep command and INH is connected to  $V_{\text{BAT}}$ . A wake-up is indicated on the RxD and NERR output pins. A mode change to Sleep Mode via Host Command is only possible via the Go-to-Sleep command. The following conditions are valid for the Go-to-Sleep command:

- The transmitter is disabled and the data available on the TxD input is blocked.
- The low power receiver is enabled and monitors the HS CAN bus for a valid Wake-Up Pattern. The RxD output pin and NERR indicate a wake-up event ([Chapter 6.9](#)). The default value of the RxD and NERR output pin are logical “high” if no wake-up event is pending.
- The Local Wake-Up pin is active.
- The bus biasing is GND if  $t_{\text{Silence}}$  is expired. The conditions for the bus biasing are defined in [Chapter 6.7](#).
- The TxD time-out function is disabled.
- The RxD Recessive Clamping detection is disabled.
- The overtemperature protection is disabled.
- The undervoltage detection on  $V_{\text{BAT}}$ ,  $V_{\text{CC}}$  and  $V_{\text{IO}}$  are enabled (see [Chapter 7.2](#)).
- The INH output pin is connected to  $V_{\text{BAT}}$  if the timer  $t_{\text{SLEEP}}$  is not expired OR a wake-up is pending OR the POR is set. If  $t_{\text{SLEEP}}$  is expired and no wake-up is pending and the POR Flag is reset, the INH output pin is high impedance.

Conditions for entering the Go-to-Sleep command:

Go-to-Sleep command is entered from Normal-operating Mode, Receive-only Mode and Stand-by Mode by setting the NSTB input pin to logical “low” AND EN input pin to logical “high”.

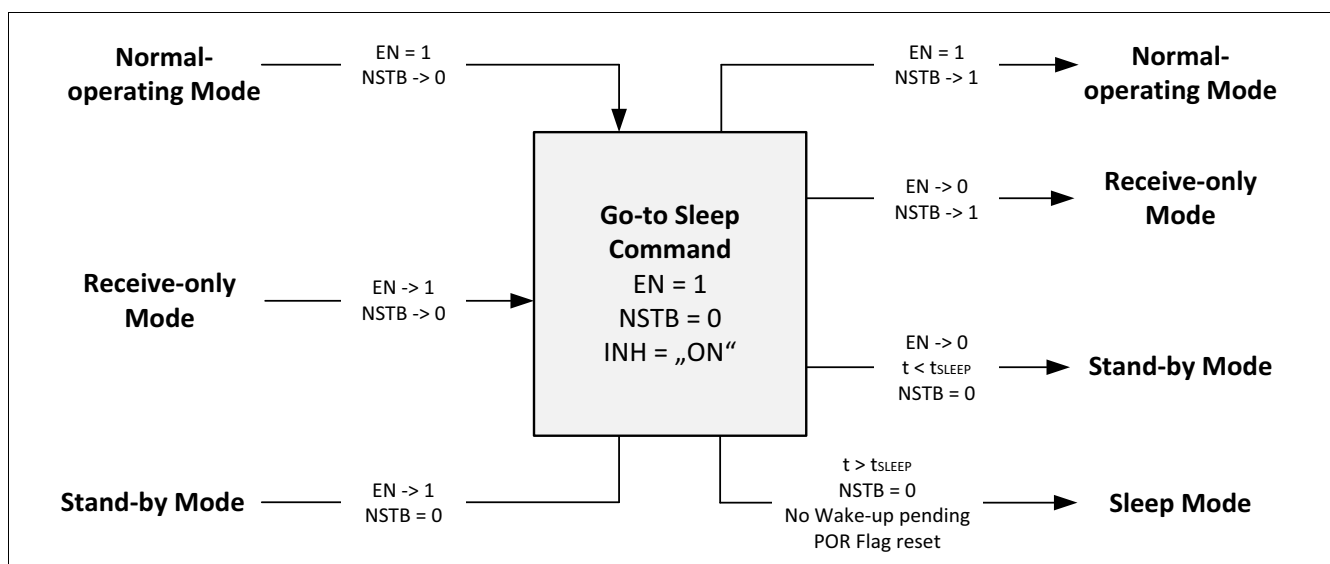

Figure 8 Mode changes in Go-to-Sleep command

## TLT9252VLC

### High-Speed CAN FD Transceiver

#### Modes of operation

### 6.5 Sleep Mode

Sleep Mode is a low power mode of the TLT9252VLC. In Sleep Mode the current consumption is reduced to a minimum while the device is still able to detect a Wake-Up Pattern (WUP) on the HS CAN Bus OR a Local Wake-Up event on the WAKE pin. The following conditions are valid for the Sleep Mode:

- The transmitter is disabled and the data available on the TxD input is blocked.
- The low power receiver is enabled and monitors the HS CAN bus for a valid Wake-Up Pattern.
- The default value of the RxD and NERR output pin are logical “high” if no wake-up event is pending AND  $V_{IO}$  is in the functional range (see [Chapter 8](#)).
- The Local Wake-Up pin is active.
- The bus biasing is connected to GND. The conditions for the bus biasing are defined in [Chapter 6.7](#).
- The TxD time-out function is disabled.
- The RxD Recessive Clamping detection is disabled.
- The overtemperature protection is disabled.
- The undervoltage detection on  $V_{BAT}$  is disabled.
- The undervoltage detection on  $V_{CC}$  is disabled.
- The undervoltage detection on  $V_{IO}$  is enabled (see [Chapter 7.2.3](#)).
- The INH output pin is High-Z.

Conditions for entering the Sleep Mode:

- The Sleep Mode will be entered if  $V_{IO} < V_{IO\_UV}$  AND  $t_{VIO\_UV\_T}$  AND  $t_{Silence}$  has been expired in Normal-operating Mode, Receive-only Mode, Stand-by Mode and Go-to-Sleep command.
- The Sleep Mode will be entered if  $V_{CC} < V_{CC\_UV}$  AND  $t_{VCC\_UV\_T}$  AND  $t_{Silence}$  has been expired in Normal-operating Mode, Receive-only Mode, Stand-by Mode and Go-to-Sleep command.
- The Sleep Mode can be entered through Go-to-Sleep command if NSTB is set to logical “low” AND  $t_{SLEEP}$  is expired AND no wake-up is pending AND the POR flag is reset.

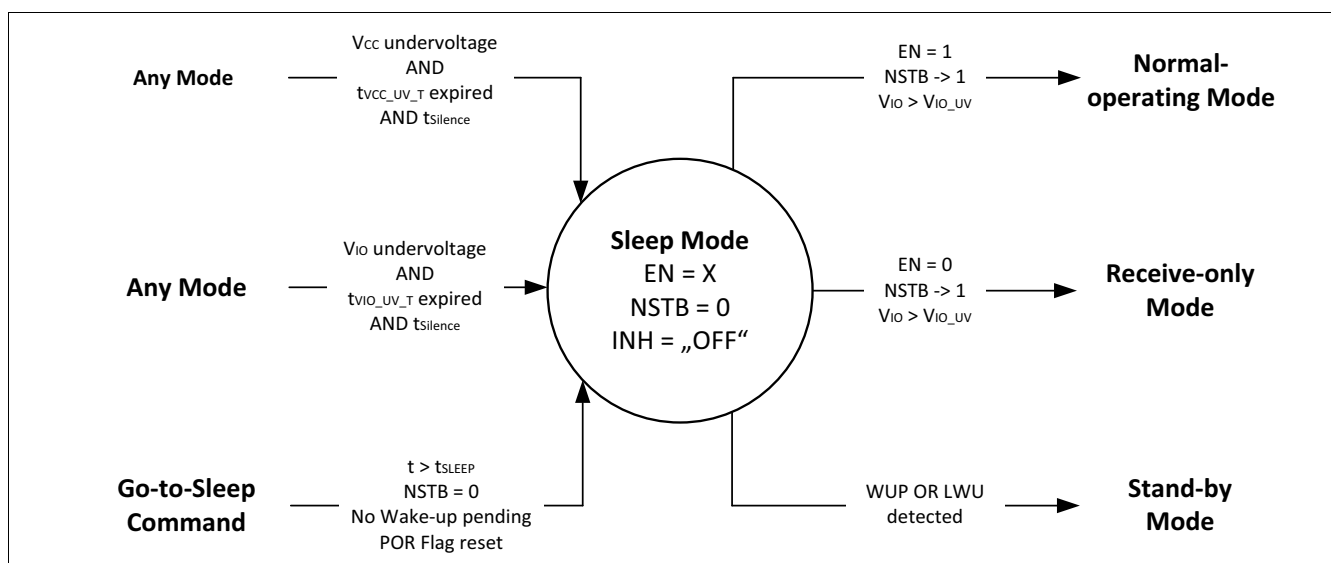

**Figure 9** Mode changes in Sleep Mode

#### 6.5.1 Mode change to Sleep Mode or Stand-by Mode

If the logical signal on the EN pin goes “low” before the transition time  $t < t_{SLEEP}$  has been reached, the TLT9252VLC enters Stand-by Mode and the INH pin remains connected to  $V_{BAT}$ . In the case the logical signal on

# TLT9252VLC

## High-Speed CAN FD Transceiver

### Modes of operation

the EN pin goes “low” after the transition time  $t > t_{SLEEP}$ , the TLT9252VLC enters Sleep Mode with the expiration of  $t_{SLEEP}$ . The signal on the HS CAN bus has no impact to the mode change. The mode of operation can be changed regardless if the CAN bus is dominant or recessive.

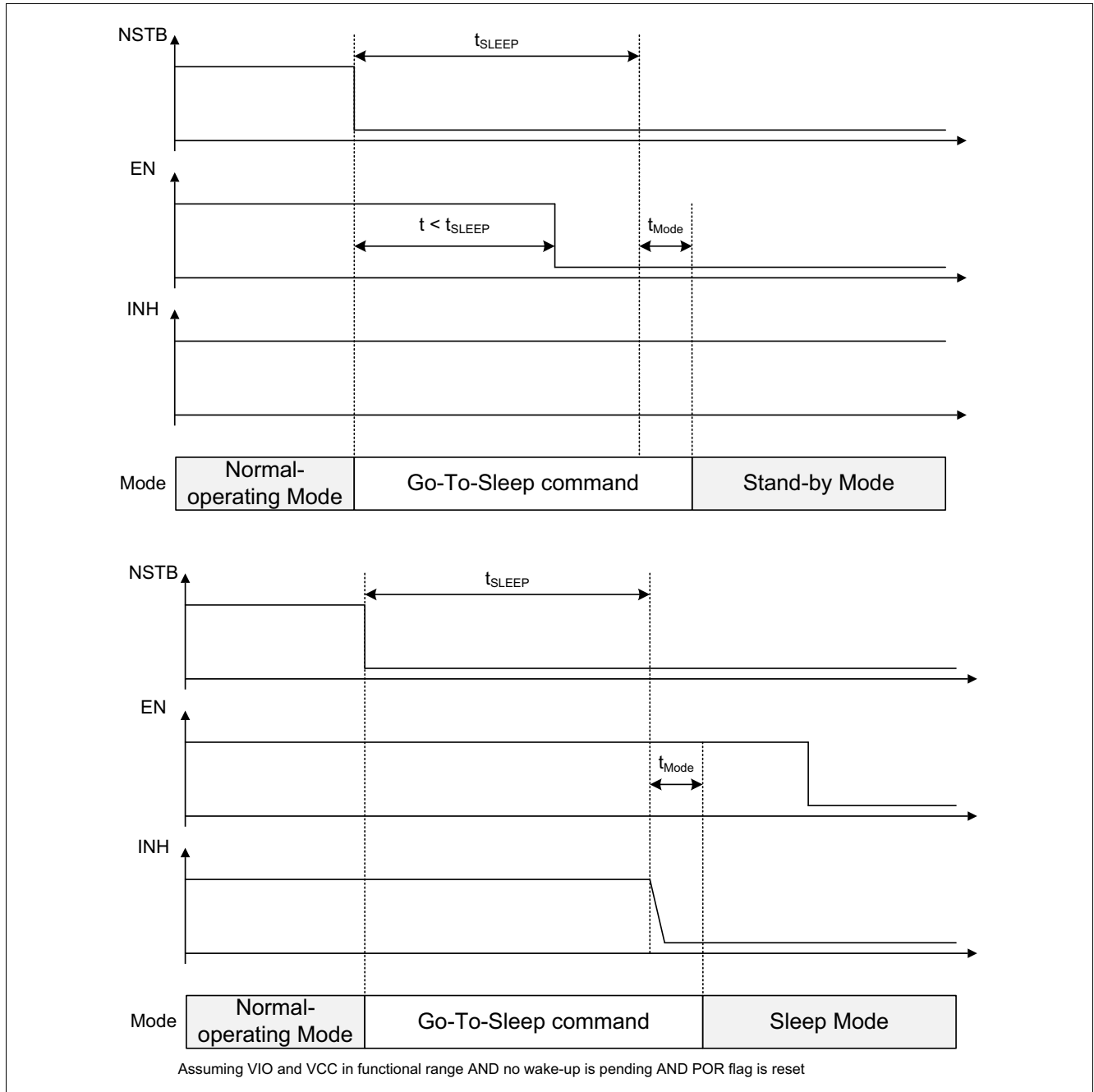

**Figure 10 Mode change to Stand-by Mode or Sleep Mode**

## TLT9252VLC

### High-Speed CAN FD Transceiver

#### Modes of operation

#### 6.5.2 Mode Change via EN and NSTB pin

Besides a mode change from Sleep Mode to Stand-by Mode issued by a wake-up event, the mode of operation can be changed by changing the signals on the EN and NSTB input pins. Therefore the reference voltage  $V_{IO}$  has to be in the functional range. According to the mode diagram (see [Figure 4](#)) the mode of operation can be changed directly from Sleep Mode to Receive-only Mode or Normal-operating Mode. In Sleep Mode once a rising edge on the pin NSTB is detected ( $V_{IO} > V_{IO\_UV}$ ) either Normal-operating Mode or Receive-only Mode will be entered, depending on the signal on the EN pin. The device will stay in Sleep Mode regardless of the signal on the EN input pin if NSTB is statically logical “low”. A mode change to from Sleep Mode to Stand-by Mode is only possible via a wake-up event.

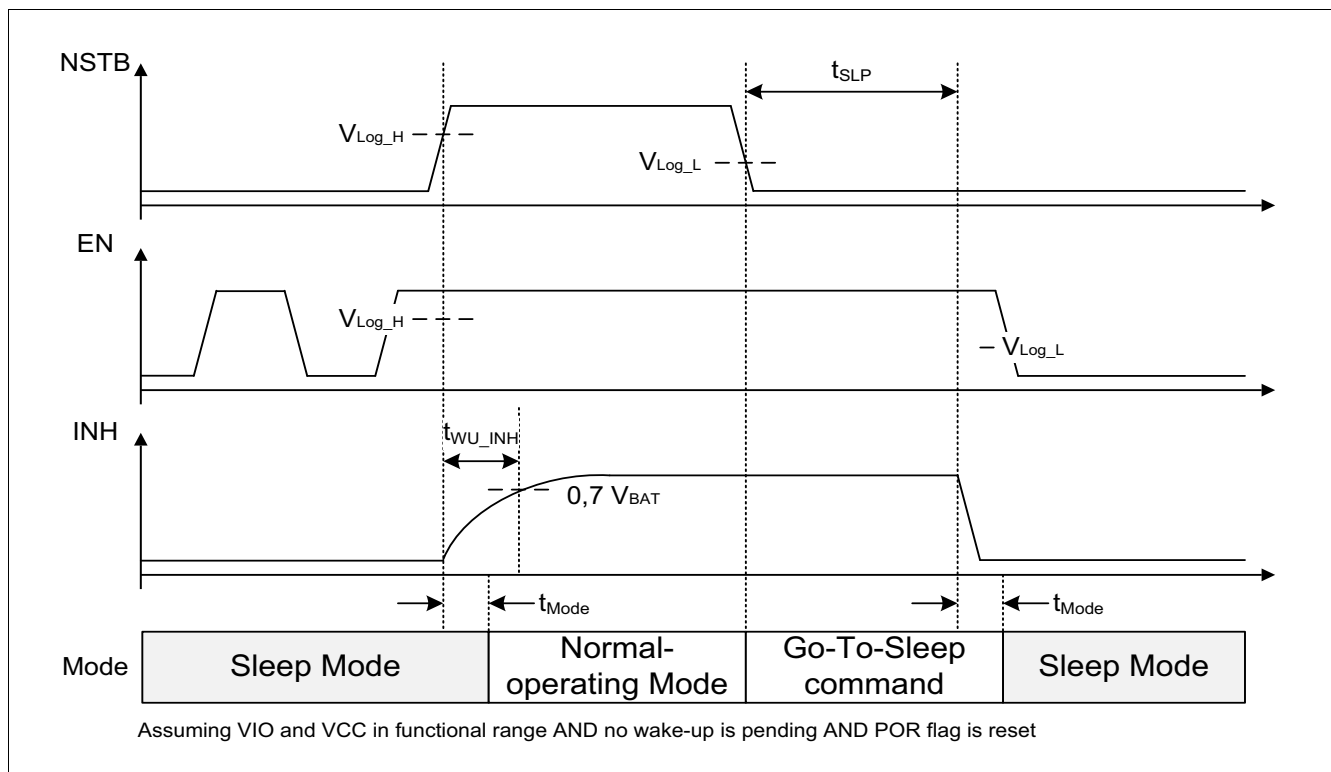

**Figure 11 Mode change via EN and NSTB in Sleep Mode**

## TLT9252VLC

### High-Speed CAN FD Transceiver

#### Modes of operation

### 6.6 Power On Reset

In Power On Reset all functions of the TLT9252VLC are disabled and the device is switched off.

- The transmitter and receiver are disabled.
- The bus biasing is connected to High impedance.
- The RxD Recessive Clamping detection is disabled
- The TxD time-out function is disabled.
- The overtemperature protection is disabled.
- The undervoltage detection on  $V_{BAT}$ ,  $V_{CC}$  and  $V_{IO}$  is disabled.
- The logical input pins are blocked.
- RxD and NERR output pins are high impedance.
- Local Wake-Up is disabled.
- The INH output pin is connected to  $V_{BAT}$  if  $V_{BAT} > V_{BAT\_POD}$  OR  $V_{CC} > V_{CC\_UV}$ .

Conditions for entering the Power On Reset:

- $V_{BAT}$  is below the  $V_{BAT\_POD}$  AND  $V_{CC}$  is below  $V_{CC\_UV}$  threshold.

Conditions for leaving the Power On Reset:

- Once the power supply voltage  $V_{BAT}$  OR  $V_{CC}$  is within the functional range the transceiver enters Stand-by Mode within  $t_{PON}$ .

The internal Power On Reset flag will be set. After Power On Reset the TLT9252VLC enters Stand-by Mode.

Power-up and power-down transition is described in [Figure 12](#):

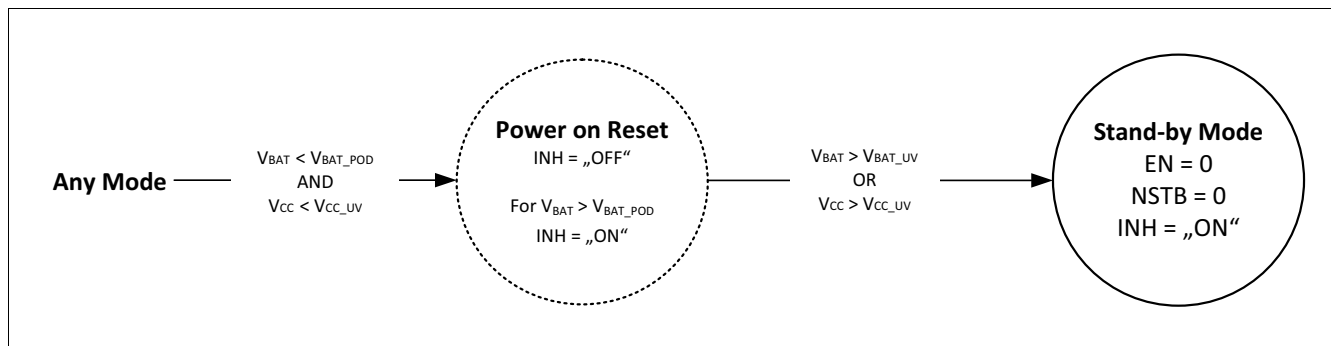

**Figure 12 Power-down and power-up behavior**



# TLT9252VLC

## High-Speed CAN FD Transceiver

### Modes of operation

#### 6.7 Autonomous bus voltage biasing

The autonomous bus voltage biasing was introduced for improving complete network EMC performance and increasing the reliability of communication performance in networks using CAN networks. The autonomous bus voltage biasing is enabled in all modes of Operation. The biasing unit will work independently from other transceiver functions and depends only on the status of detected network activity ( $t_{Silence}$ ). **Figure 13** describes the behavior for active and for low power modes in Detail as well as the status after a power-on reset event.

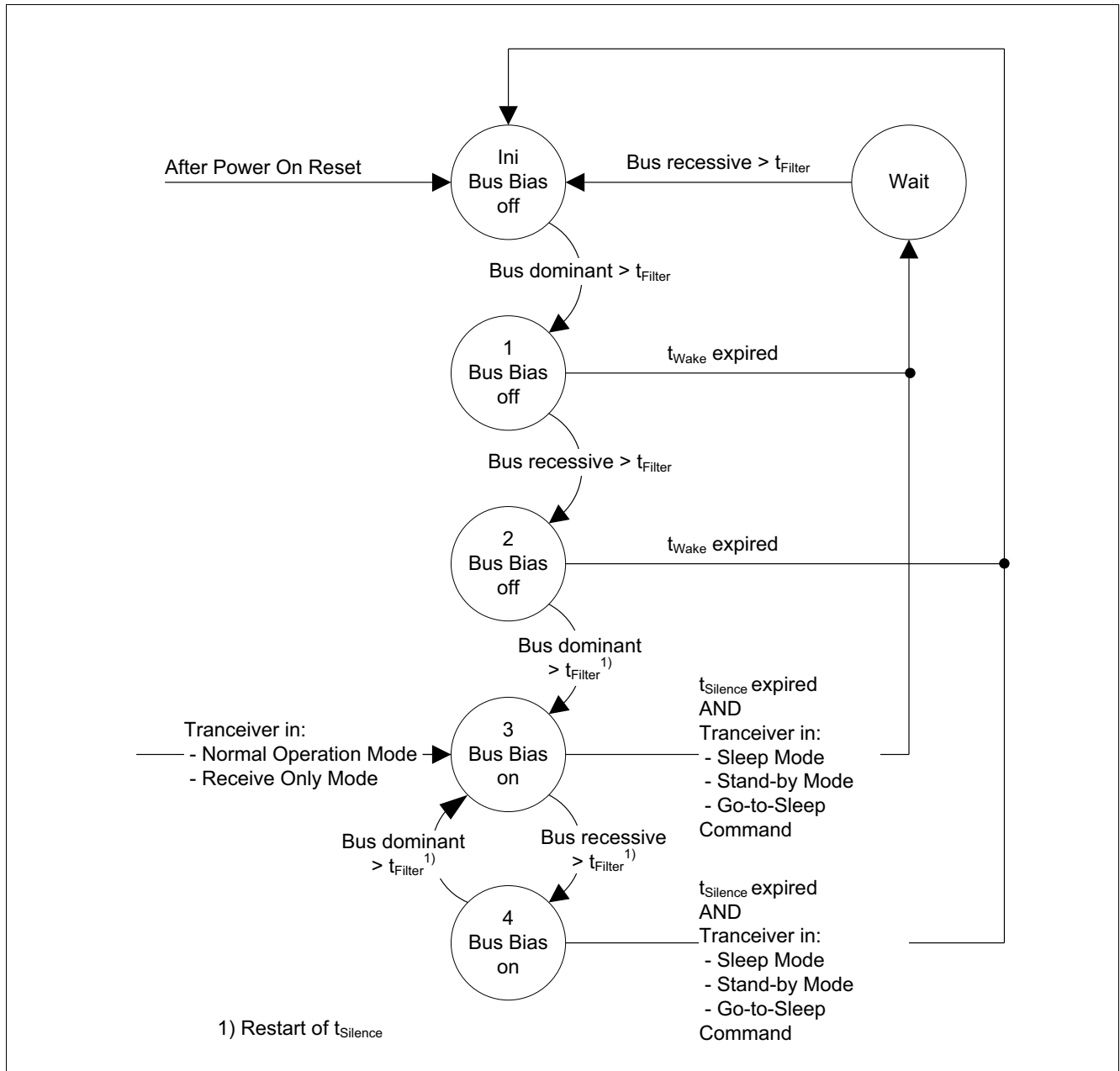

**Figure 13 Autonomous Bus Voltage Biasing**

In low power modes, in case there has been no activity on the bus for longer than  $t_{Silence}$ , the bus pins are biased towards GND via the internal resistors. With the detection of a valid Wake-Up Pattern (WUP), the internal biasing gets enabled and the biasing is stabilized via internal resistors towards 2.5 V. This activation is being performed within the time  $t > t_{WU\_Bias}$  after the WUP detection.

## TLT9252VLC

### High-Speed CAN FD Transceiver

#### Modes of operation

### 6.8 Wake-Up functions

There are several possibilities for a mode change from Sleep Mode to another operation mode:

- Wake-Up Pattern (WUP)
- Local Wake-Up (LWU)

In typical applications the power supplies  $V_{CC}$  and  $V_{IO}$  are turned off in Sleep Mode. This means a mode change can only be caused by an external event as WUP OR LWU. The detection of a valid WUP or LWU triggers a mode change from Sleep Mode to Stand-by Mode.

#### 6.8.1 Wake-up Pattern (WUP)

Within the maximum wake-up time  $t_{WAKE}$ , the Wake-Up Pattern consists of a dominant signal with the pulse width  $t > t_{Filter}$ , followed by a recessive signal with the pulse width  $t > t_{Filter}$  and another dominant signal with the pulse width  $t > t_{Filter}$  (see [Figure 14](#)).

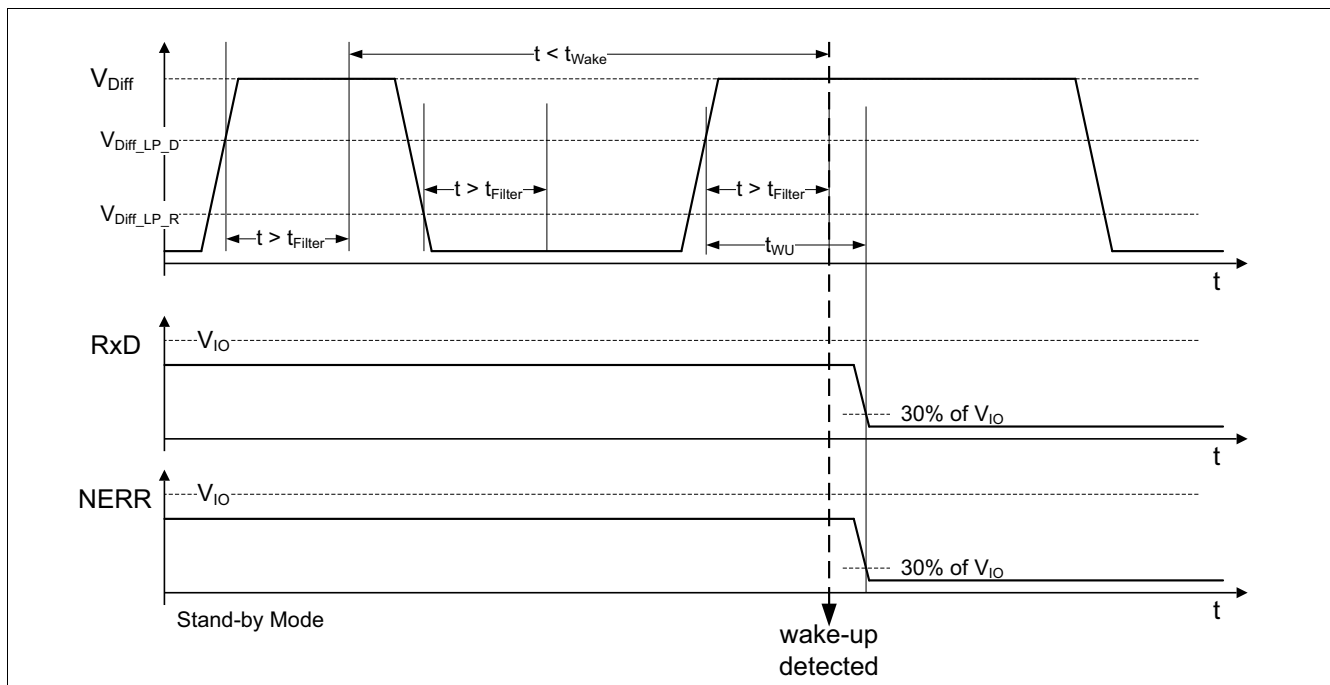

**Figure 14** Wake-Up Pattern (WUP)

The diagnostic output NERR and RxD will indicate a valid Wake-Up Pattern on the HS CAN bus.

A Wake-Up Pattern is not valid under the following conditions:

- A mode change to Normal-operating Mode OR Receive-only Mode is performed during the Wake-Up Pattern.
- The maximum wake-up time  $t_{WAKE}$  expires before a valid WUP has been detected.
- The transceiver is powered down ( $V_{BAT} < V_{BAT\_POD}$  AND  $V_{CC} < V_{CC\_POD}$ ).

In Stand-by Mode the RxD output pin and the NERR diagnostic pin display the WUP detection (Details see [Chapter 8](#)).

## TLT9252VLC

### High-Speed CAN FD Transceiver

#### Modes of operation

#### 6.8.2 Local Wake-Up (LWU)

The WAKE input pin works bi-sensitive, meaning it is able to detect a rising and falling edge as a wake-up event. Designed to withstand up to 40 V the WAKE pin can be directly connected to  $V_{BAT}$ . The Local Wake-Up detection works for  $V_{BAT} > V_{BAT\_UV}$ . The Local Wake-Up timings and behavior is described in [Figure 15](#).

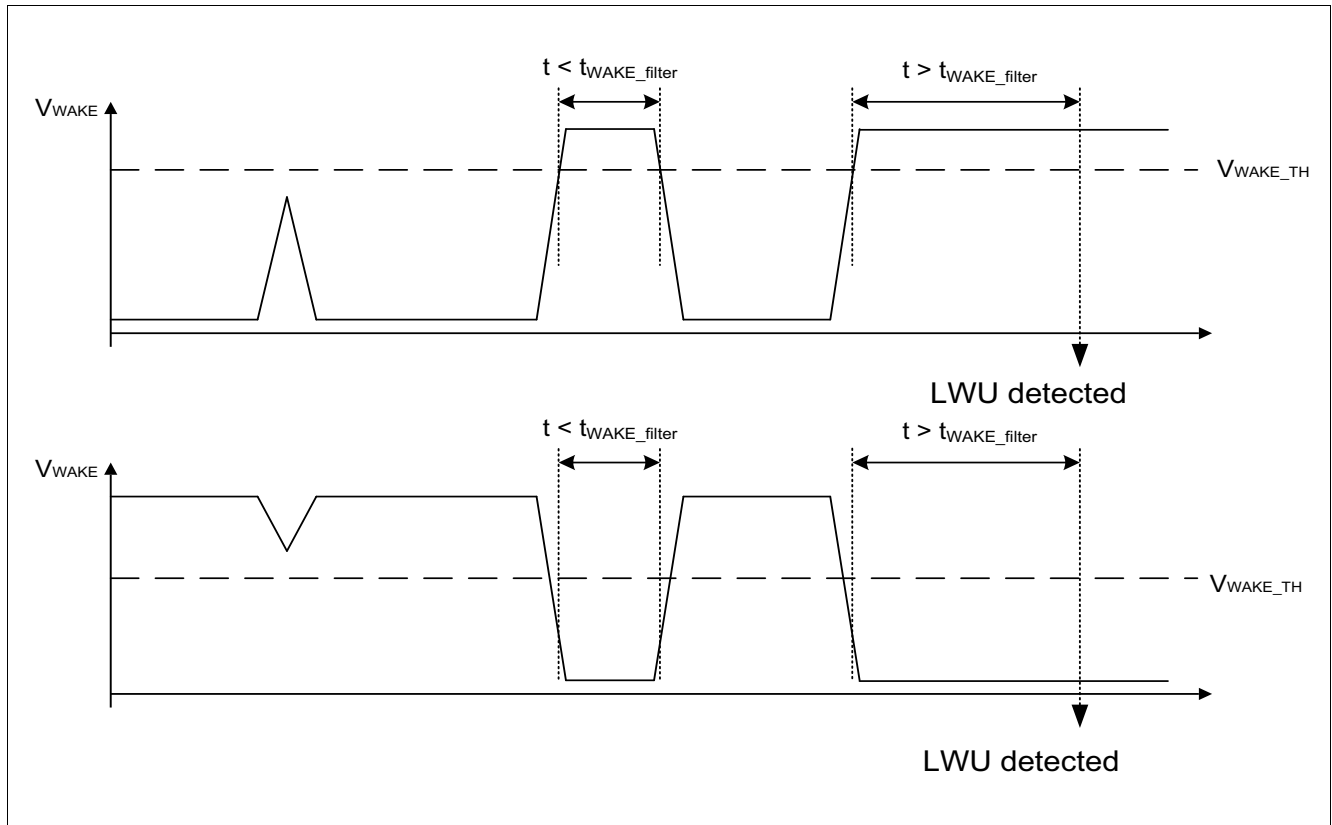

**Figure 15** Local Wake-Up

The filter time  $t_{WAKE\_filter}$  is implemented to protect the TLT9252VLC against unintended Wake-Ups, caused by spikes on the WAKE pin. The wake-up thresholds  $V_{WAKE\_TH}$  depend on the level of the  $V_{BAT}$  power supply. In Stand-by Mode the RxD output pin and the NERR diagnostic pin display the wake-up event (Details see [Chapter 8](#)). Once a LWU has been recognized in Sleep Mode the device goes to Stand-by mode and the INH output pin is connected to  $V_{BAT}$ .

# TLT9252VLC

## High-Speed CAN FD Transceiver

### Modes of operation

#### 6.9 Wake-up: RxD and NERR behavior

The RxD and NERR output pin will signal a wake up event to the microcontroller (see [Chapter 8](#)). In Sleep Mode, Stand-by Mode and Go-to-Sleep command by default values of RxD and NERR are logical “high” when no wake-up event has been detected. If a valid wake up pattern (WUP) is detected, RxD and NERR will be logical “low”. If a Local Wake-Up (LWU) is detected the RxD will be logical “low” and NERR will be logical “high”. If both, LWU and WUP have been detected, then the WUP detection has higher priority and RxD and NERR pin are set to logical “low”, regardless if a LWU event is pending.

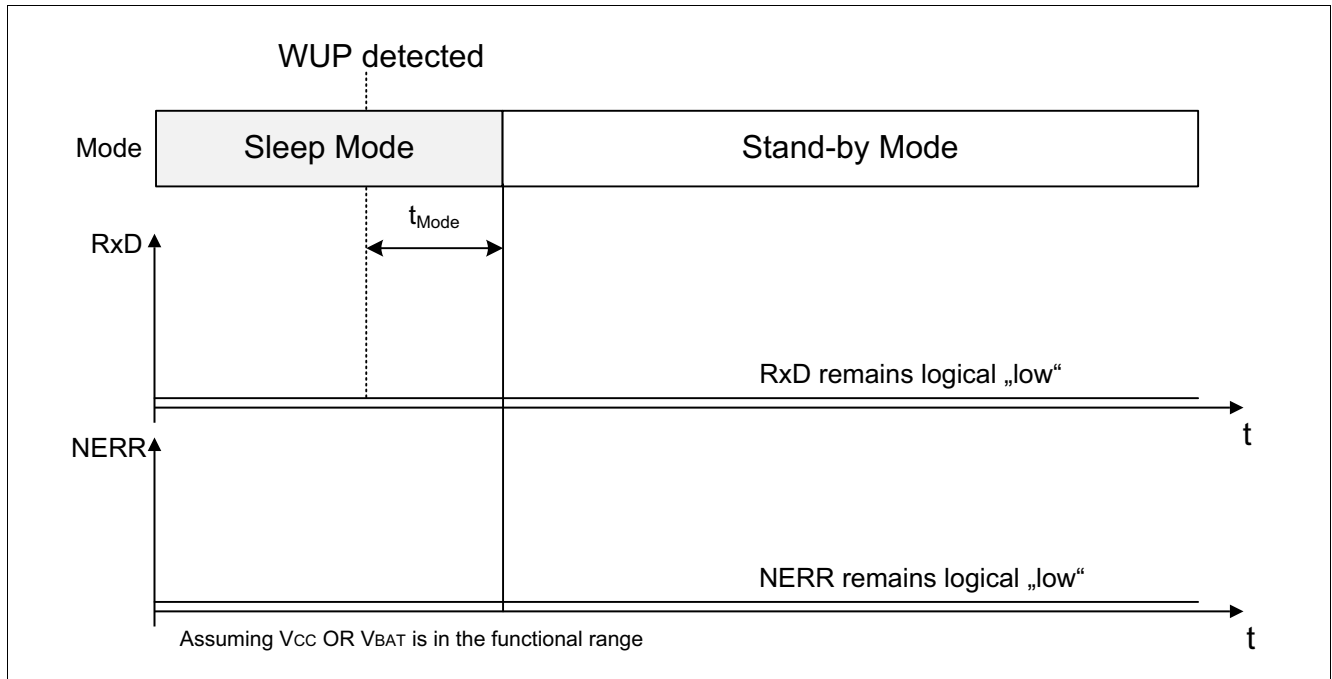

**Figure 16 RxD and NERR: WUP detection ( $V_{IO}$  not supplied)**

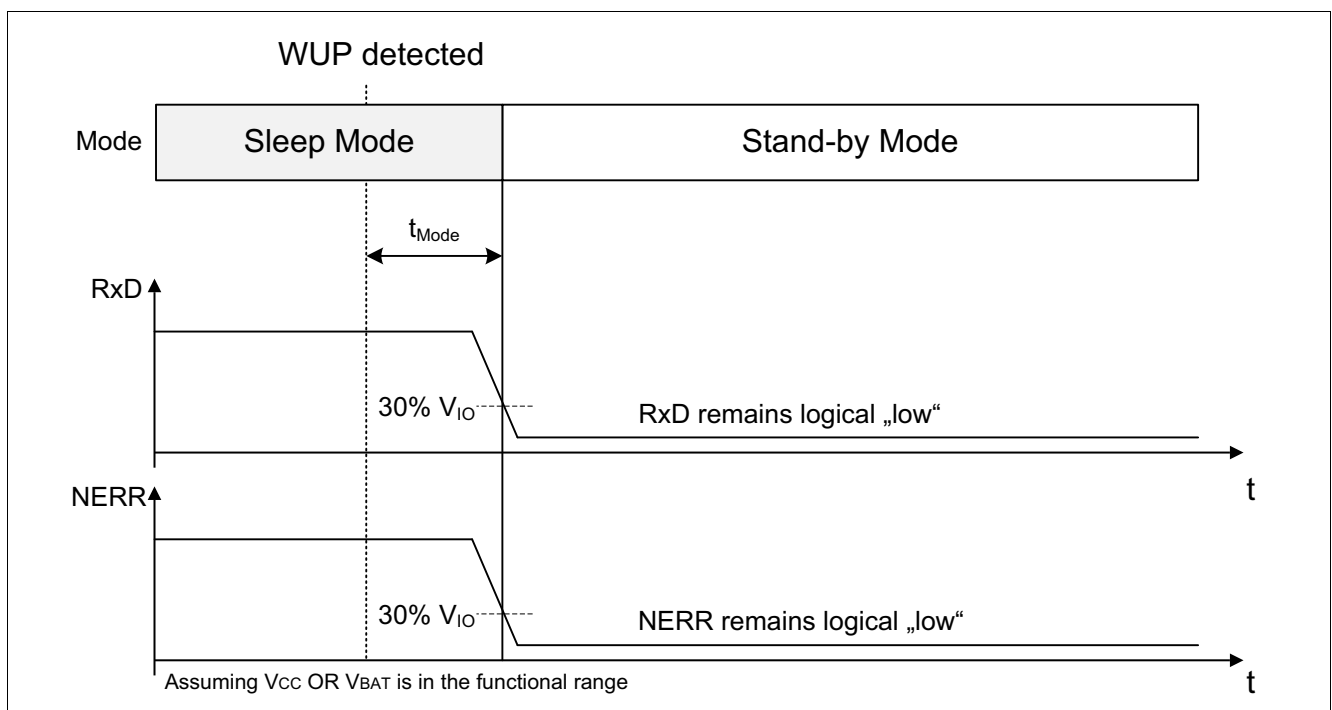
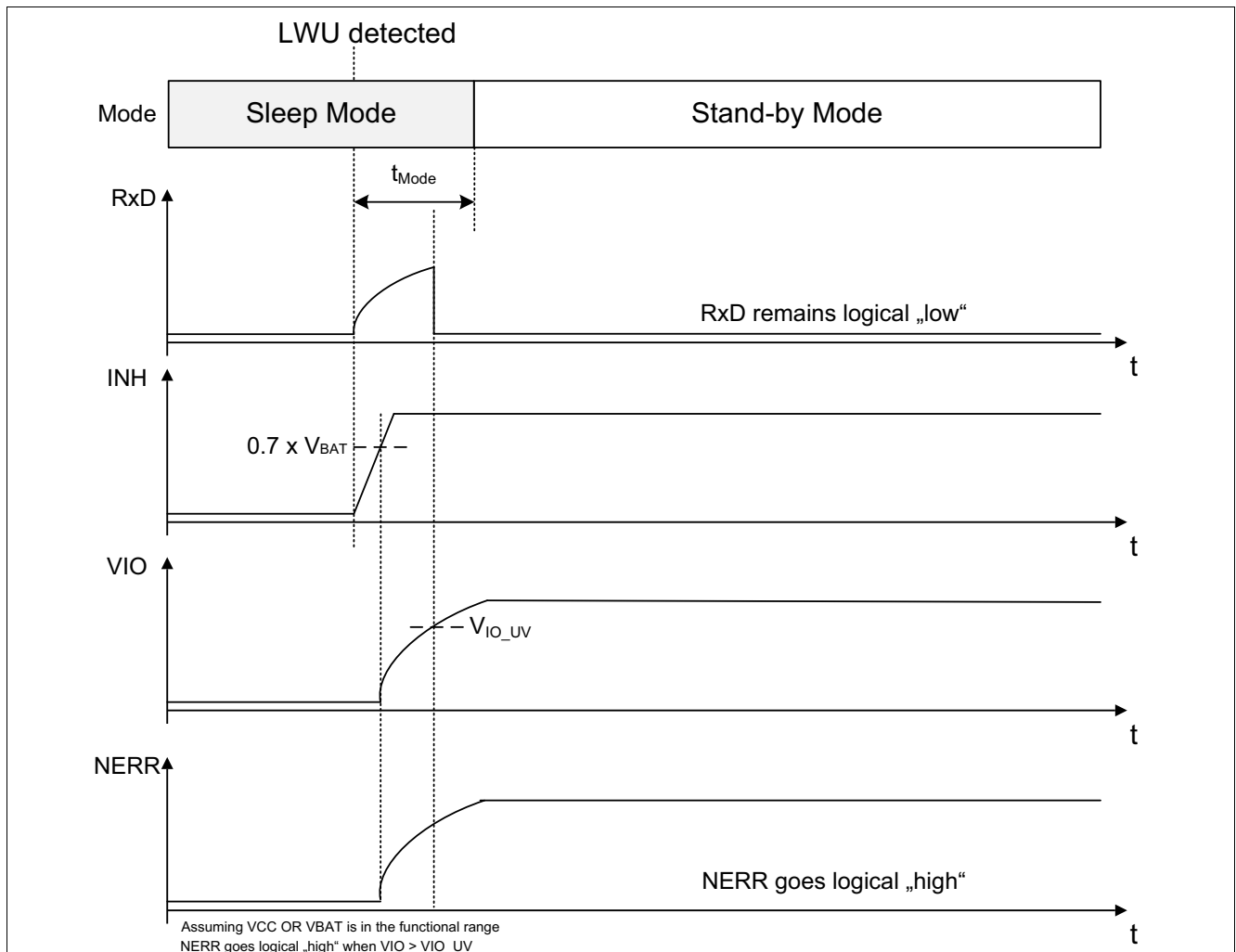

**Figure 17 RxD and NERR: WUP detection (permanently supplied  $V_{IO}$ )**

# TLT9252VLC

## High-Speed CAN FD Transceiver

### Modes of operation



**Figure 18 RxD and NERR: LWU detection ( $V_{IO}$  not supplied)**

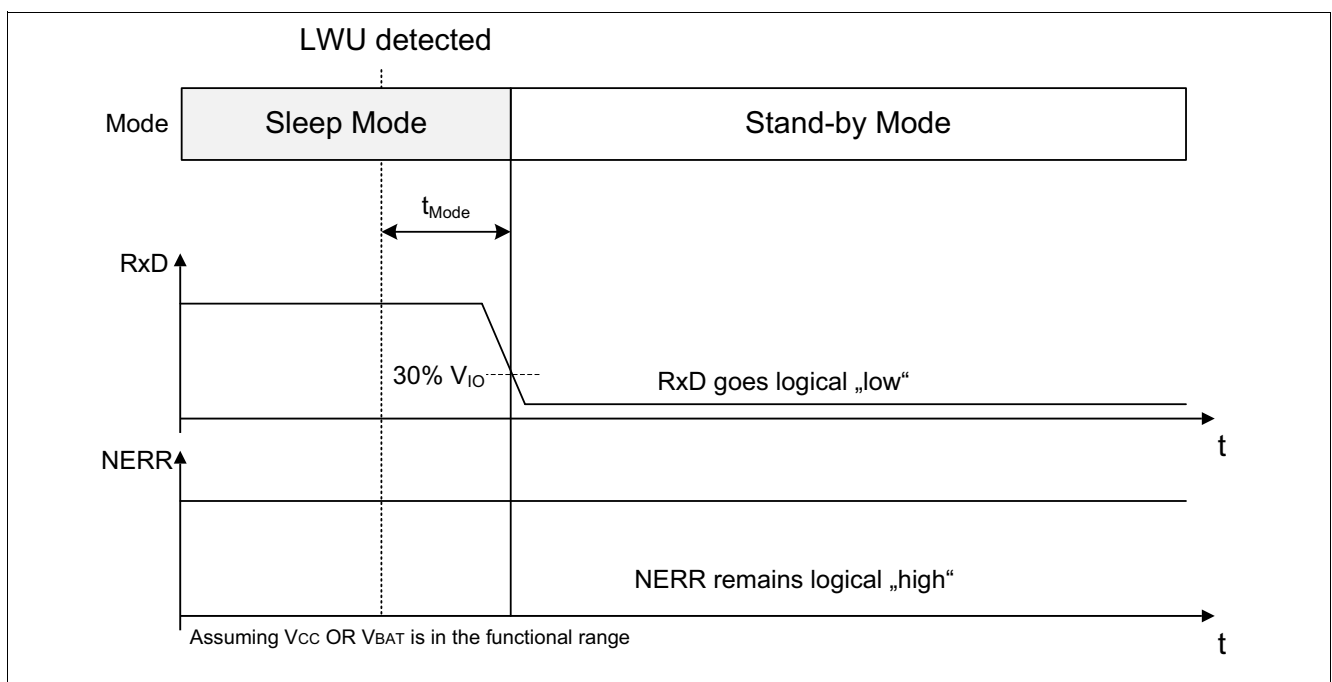

**Figure 19 RxD and NERR: LWU detection (permanently supplied  $V_{IO}$ )**

# TLT9252VLC

## High-Speed CAN FD Transceiver

### Fail safe functions

## 7 Fail safe functions

### 7.1 Short Circuit Protection

The CANH and CANL bus pins are proven to withstand a short circuit fault against GND and against the supply voltages. A current limiting circuit protects the transceiver against damages.

### 7.2 Undervoltage detection

The TLT9252VLC has three independent undervoltage detections:  $V_{BAT}$ ,  $V_{CC}$  and  $V_{IO}$ . Undervoltage events may have impact on the functionality of the device and also may change the mode of operation (see [Chapter 6](#)).

#### 7.2.1 Undervoltage and power-down detection on $V_{BAT}$

The power-down is detected if the power supply  $V_{BAT}$  is below  $V_{BAT\_POD}$  for more than the glitch filter time  $t_{VBAT\_filter}$ . This glitch filter is implemented in order to prevent an undervoltage detection due to short voltage transients on  $V_{BAT}$ . In case of an power-down detection on  $V_{BAT}$  the TLT9252VLC is switched off (Power On Reset). If  $V_{BAT}$  recovers ( $V_{BAT} > V_{BAT\_UV}$ ) the TLT9252VLC enters by default Stand-by Mode. If  $V_{BAT} > V_{BAT\_POD}$  the INH output pin is connected to  $V_{BAT}$ . [Figure 20](#) shows the undervoltage scenario.

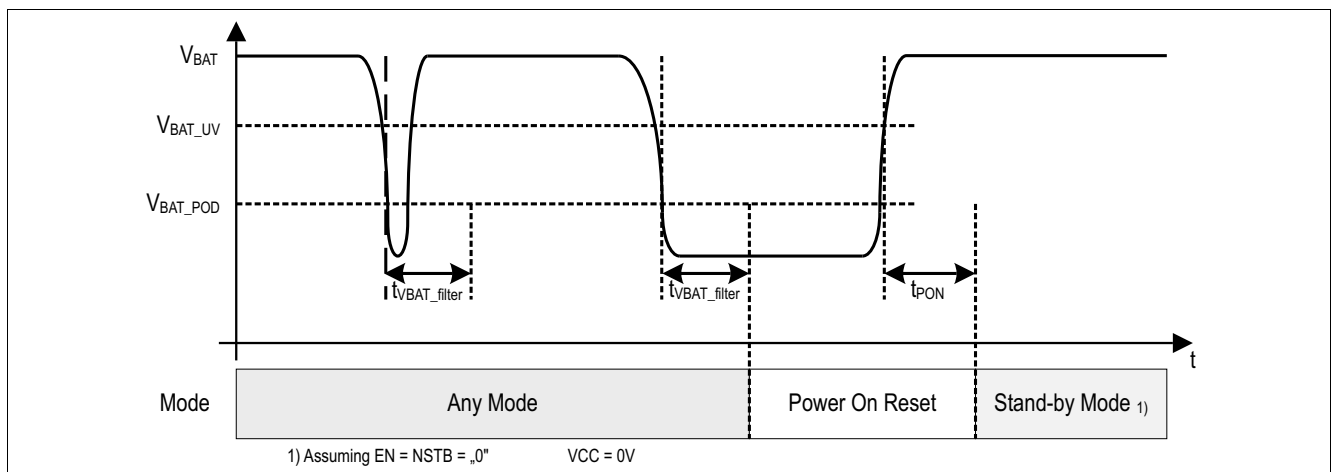

**Figure 20**  $V_{BAT}$  power-down undervoltage detection ( $V_{CC}$  not available)

If an undervoltage is detected  $V_{BAT} < V_{BAT\_UV}$  for  $t > t_{VBAT\_filter}$  the Local Wake-Up function is disabled ([Figure 21](#)).

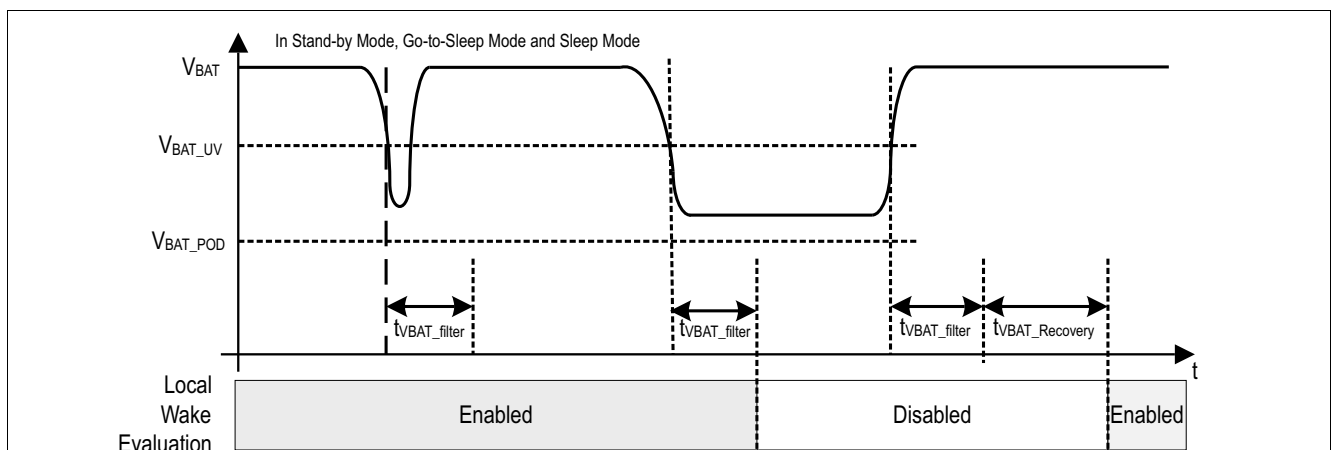

**Figure 21**  $V_{BAT}$  undervoltage detection

# TLT9252VLC

## High-Speed CAN FD Transceiver

### Fail safe functions

#### 7.2.2 Undervoltage detection on $V_{CC}$

An undervoltage on  $V_{CC}$  is detected if the  $V_{CC}$  supply is below  $V_{CC\_UV}$  for more than the glitch filter time  $t_{VCC\_filter}$ . This glitch filter is implemented in order to prevent an undervoltage detection due to short voltage transients on  $V_{CC}$ . The following actions will be performed if a undervoltage has been detected:

- The NERR pin switches from logical “high” to “low” (In Normal-operating Mode and Receive-only Mode).
- The transmitter is disabled (Normal-operating Mode).

The transmitter will be re-enabled if the  $V_{CC} > V_{CC\_UV}$  for more than the glitch filter time  $t > t_{VCC\_filter} + t_{VCC\_RECOVERY}$  in Normal-operating Mode.

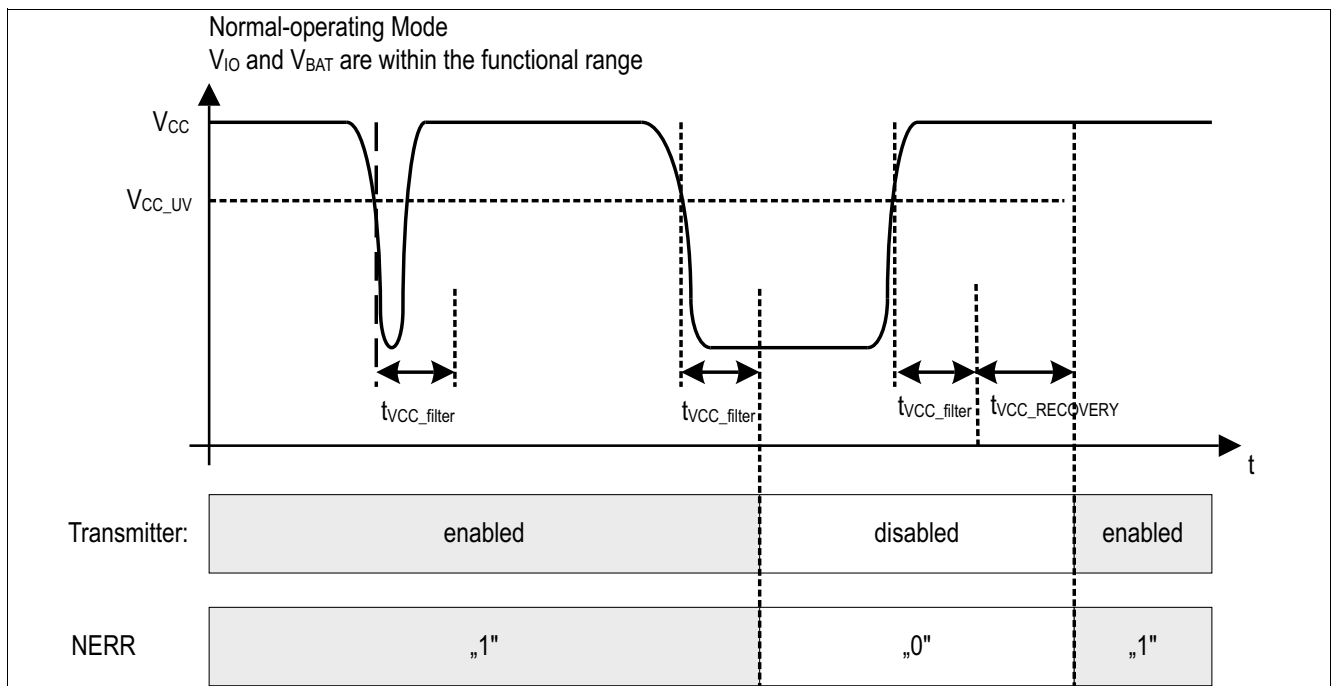

Figure 22  $V_{CC}$  short-term undervoltage detection ( $V_{BAT}$  in functional range)

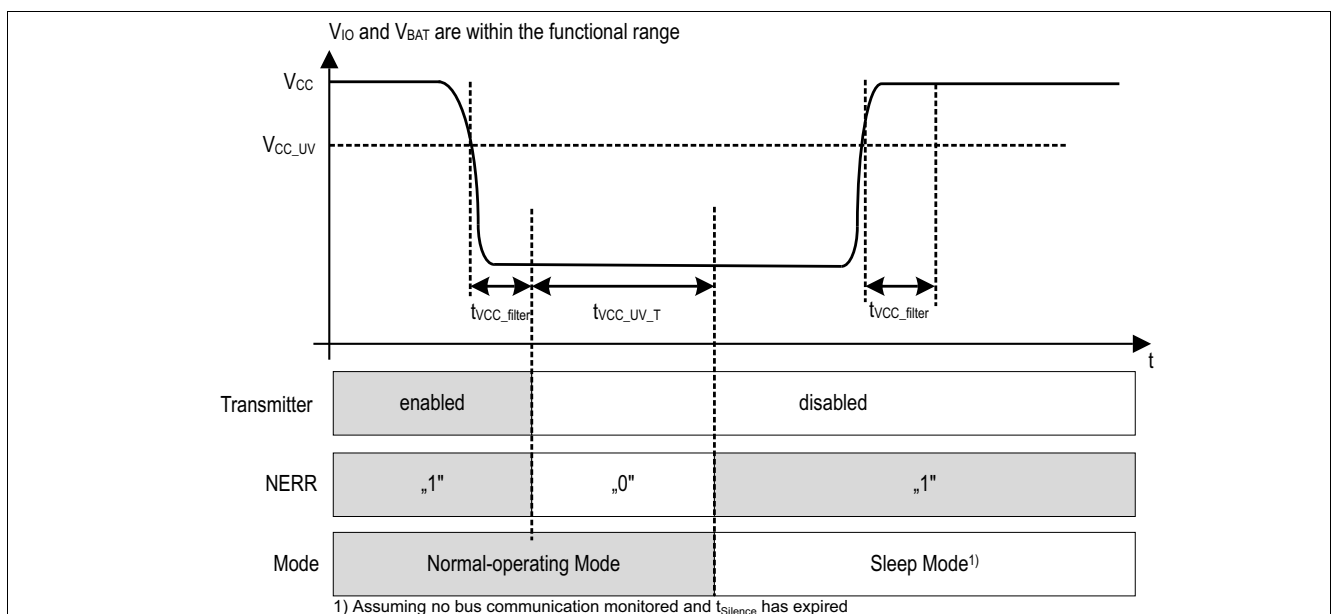

Figure 23  $V_{CC}$  long-term undervoltage detection



# TLT9252VLC

## High-Speed CAN FD Transceiver

### Fail safe functions

The  $V_{CC}$  long-term undervoltage timer  $t_{V_{CC\_UV\_T}}$  is armed once  $V_{BAT}$  is in the functional range. If the  $V_{CC}$  voltage drops below  $V_{CC\_UV}$  for longer than  $t > t_{V_{CC\_UV\_T}}$  AND no communication is monitored on the HS CAN Bus ( $t_{Silence}$  is expired), this will trigger a mode change from any mode to Sleep Mode. If during the undervoltage event, communication is monitored and  $t_{Silence}$  does not expire, the device remains in the current mode of operation.

### 7.2.3 Undervoltage detection on $V_{IO}$

An undervoltage on  $V_{IO}$  is detected if the power supply  $V_{IO}$  is below  $V_{IO\_UV}$ . As long as  $V_{IO} < V_{IO\_UV}$  any signal on the logic input pins EN, NSTB and TxD will be blocked (see **Figure 24**). The default value of NERR and RxD if  $V_{IO} > V_{IO\_UV}$  is logical "high".

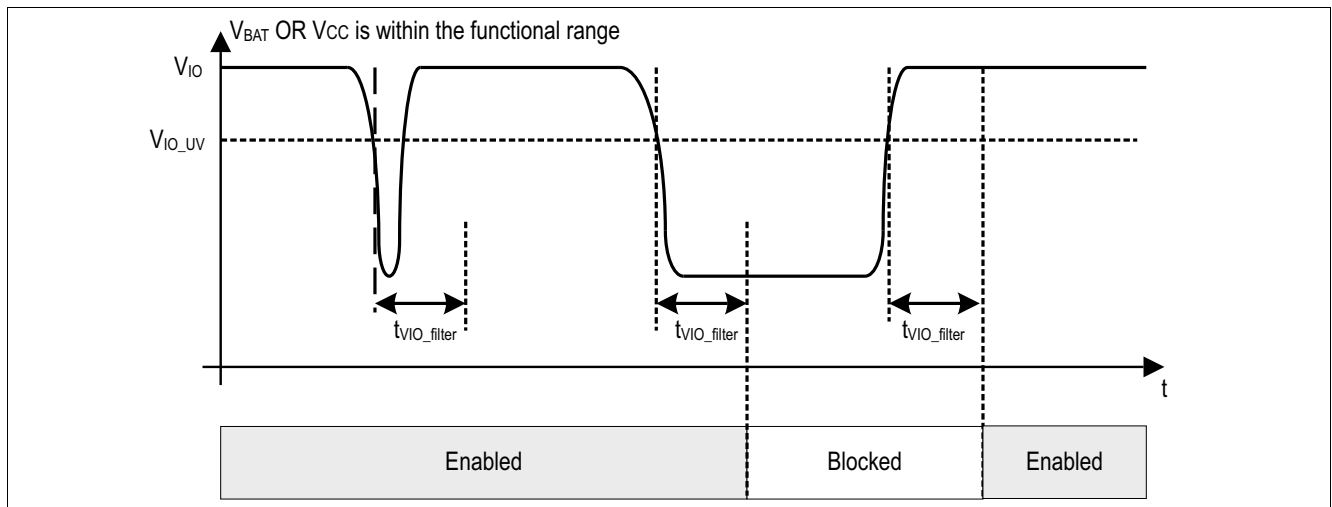

**Figure 24**  $V_{IO}$  short-term undervoltage detection

The  $V_{IO}$  long-term undervoltage timer  $t_{V_{IO\_UV\_T}}$  is armed once  $V_{BAT}$  is in the functional range. If the  $V_{IO}$  voltage drops below  $V_{IO\_UV}$  for longer than  $t > t_{V_{IO\_UV\_T}}$  AND no communication is monitored on the HS CAN bus ( $t_{Silence}$  is expired), this will trigger a mode change to Sleep Mode (see **Figure 25**). If during the undervoltage event, communication is monitored and  $t_{Silence}$  does not expire, the device does not enter Sleep Mode.

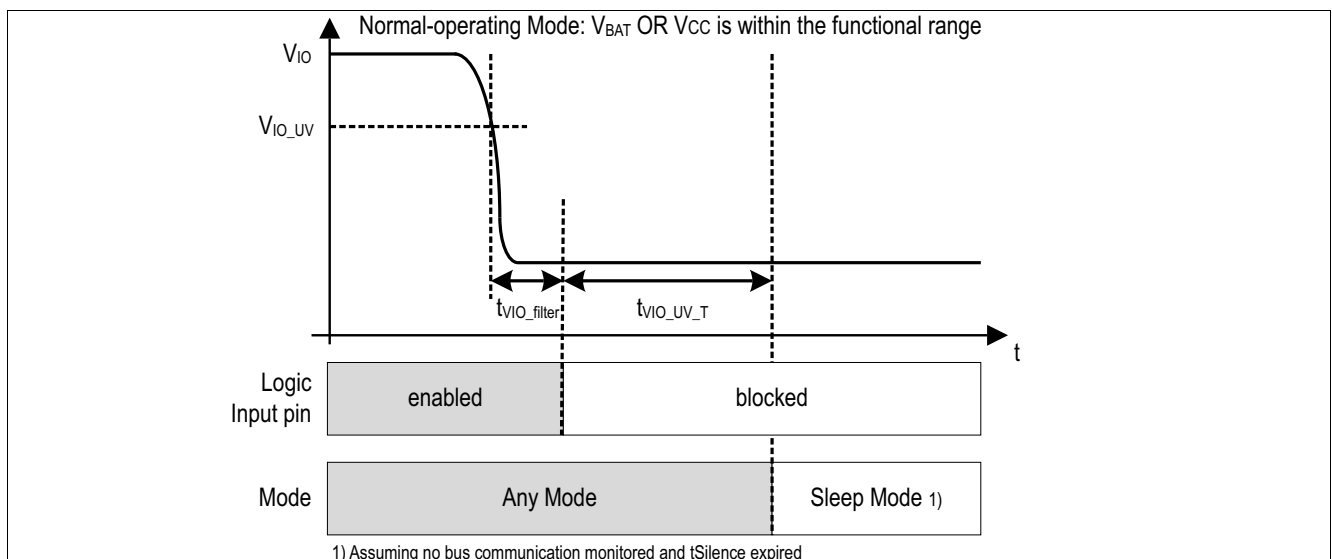

**Figure 25**  $V_{IO}$  long-term undervoltage detection

## TLT9252VLC

### High-Speed CAN FD Transceiver

#### Fail safe functions

In Low-power Mode (Stand-by Mode, Sleep Mode, Go-to-Sleep Command) bus communication requires at valid WUP detection (see [Chapter 6.8.1](#)). In Normal-operating Mode or Receive-only mode a single dominant period of  $t > t_{\text{filter}}$  is reflecting bus communication.

### 7.3 Dual Power Supply Solution

The integrated Dual Power Supply Concept of TLT9252VLC offers the possibility to supply the device with  $V_{\text{BAT}}$  OR/AND  $V_{\text{CC}}$  pin. During  $V_{\text{BAT}}$  battery supply cranking, the TLT9252VLC remains functional if  $V_{\text{CC}}$  stays in the functional range.

### 7.4 Unconnected logic pins

The integrated pull-up and pull-down resistors at the digital input pins force the TLT9252VLC into fail safe behavior if the input pins are not connected and floating (see [Table 6](#)).

**Table 6** Logical inputs when unconnected

Input signal	Default state	Comment
TxD	“High”	“Pull-up” current source to $V_{\text{IO}}$
EN	“Low”	“Pull-down” current source to GND
NSTB	“Low”	“Pull-down” current source to GND

### 7.5 TxD time-out function

The TxD time-out feature protects the CAN bus against permanent blocking in case the logical signal on the TxD pin is continuously “low”. A continuous “low” signal on the TxD pin might have its root cause in a locked-up microcontroller or in a short circuit on the printed circuit board, for example. In Normal-operating Mode, a logical “low” signal on the TxD pin for the time  $t > t_{\text{TxD\_TO}}$  enables the TxD time-out feature and the TLT9252VLC disables the transmitter (see [Figure 26](#)) and sets the NERR output pin to logical “low”. The receiver is still active and the data on the bus continues to be monitored by the RxD output pin.

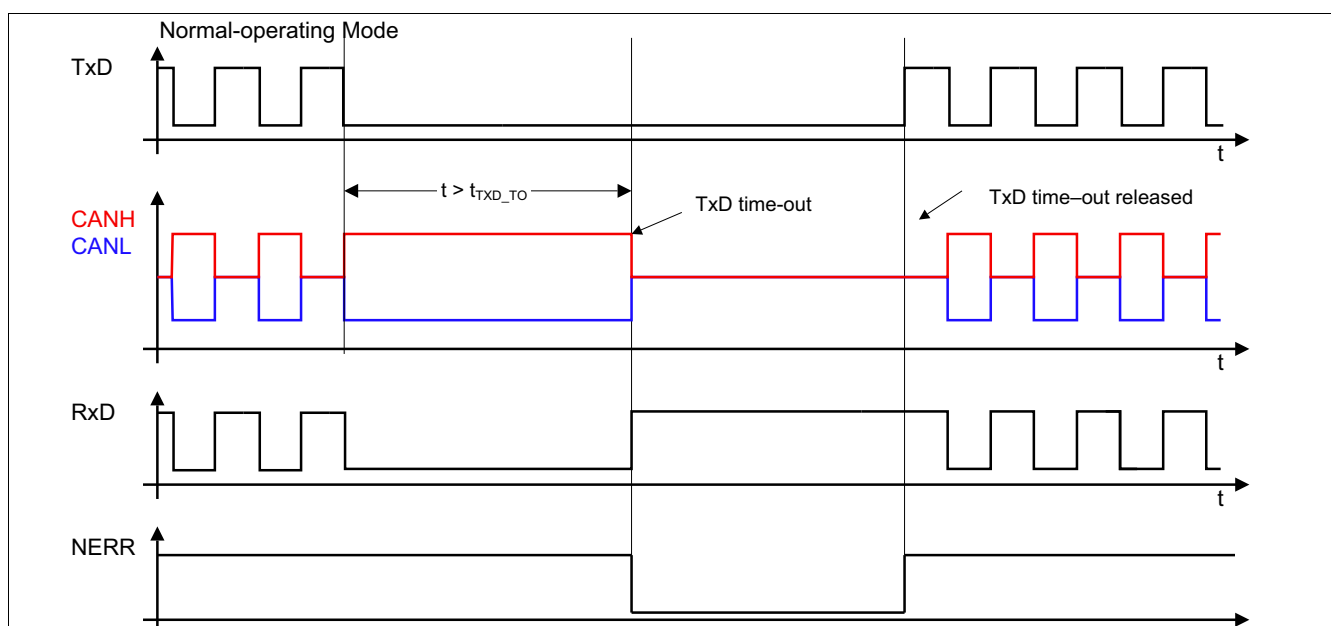

**Figure 26** TxD time-out function

## TLT9252VLC

### High-Speed CAN FD Transceiver

#### Fail safe functions

**Figure 26** illustrates how the transmitter is deactivated and re-activated. To release the transmitter after a TxD time-out event, the TLT9252VLC requires a signal change on the TxD input pin from logical “low” to logical “high”.

### 7.6 Overtemperature protection

The TLT9252VLC has an integrated overtemperature detection to protect the TLT9252VLC against thermal overstress of the transmitter. The overtemperature protection is active in Normal-operating Mode and is disabled in all other Modes. The temperature sensor provides one temperature threshold:  $T_{JSD}$ . When the temperature exceeds the threshold  $T_{JSD}$  the transmitter is disabled. This overtemperature event will be signaled as logical “low” on the NERR output pin in Normal-operating Mode. After the device has cooled down, the transmitter is re-enabled and NERR returns to logical “high”. A hysteresis is implemented within the temperature sensor.

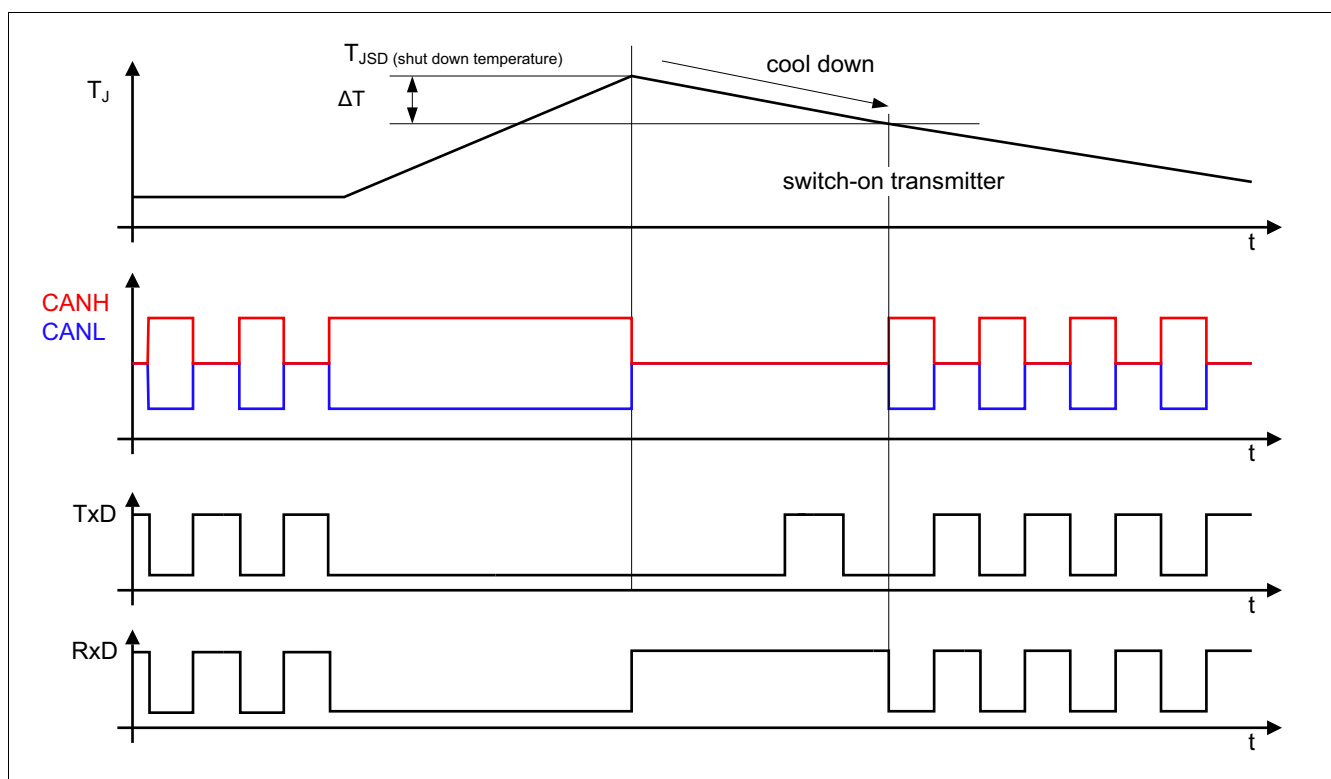

**Figure 27** Overtemperature protection

### 7.7 RxD Recessive Clamping detection

The RxD Recessive Clamping detection is only active in Normal-operating Mode. In Normal-operating mode a permanent logical “high” signal on the RxD pin indicates the external microcontroller, there is no communication on the HS CAN bus. The microcontroller then can transmit a message to the CAN bus, only if the bus is in recessive state. In case the logical “high” signal on the RxD pin is caused by a failure, like a short circuit RxD to  $V_{IO}$ , the RxD signal does not reflect the signal on the HS CAN bus. In this case the microcontroller is able to place a message on the CAN bus at any time and corrupts the CAN messages on the bus. If the TLT9252VLC detects a logical “high” signal on the RxD pin while the bus is dominant for  $t > t_{RRC}$  the RxD Recessive Clamping flag is set along with disabling the transmitter in Normal-operating Mode. In order to avoid any data collision on the CAN bus, the transmitter is disabled in Normal-operating Mode as long as the RxD-Recessive Clamping is present. In Normal-operating Mode the TLT9252VLC indicates the RxD clamping by a logical “low” signal on the NERR pin. On detection the transmitter is disabled immediately, so that the corrupted, non-synchronized node is prevented from disturbing the remaining bus traffic. The corrupted node

## TLT9252VLC

### High-Speed CAN FD Transceiver

#### Fail safe functions

is then excluded from communication. The TLT9252VLC releases the failure flag and the output stage if the RxD clamping failure disappears. Whenever the pin RXD becomes dominant while the bus signal is dominant for  $t > t_{RRC}$  the RxD Recessive Clamping flag is reset along with enabling the transmitter again in Normal-operating Mode (see [Figure 28](#)).

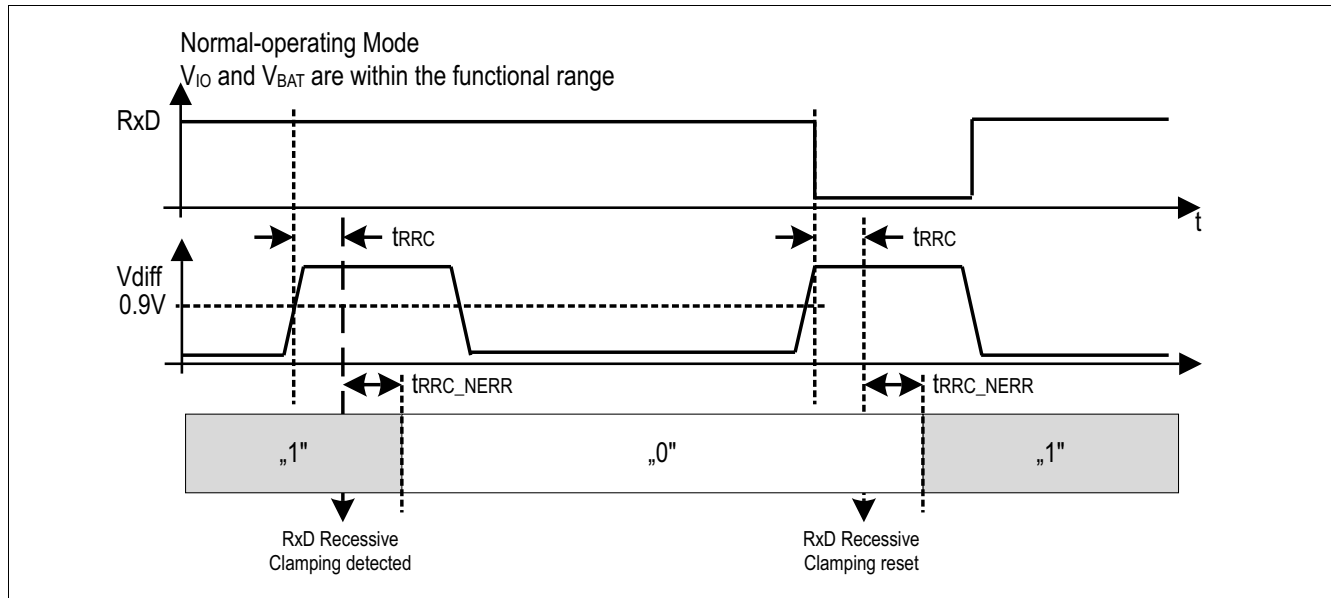

**Figure 28 RxD Recessive Clamping in Normal-operating Mode**

### 7.8 Delay time for mode change

The HS CAN transceiver TLT9252VLC changes the modes of operation within the time window  $t_{Mode}$ . During mode changes from low-power mode to Normal-operating Mode or low-power mode to Receive-only Mode, the RxD output pin is set to logical “high” and does not reflect the status on the CANH and CANL input pins.

# TLT9252VLC

## High-Speed CAN FD Transceiver



### Diagnosis-flags at NERR and RxD

## 8 Diagnosis-flags at NERR and RxD

**Table 7** Diagnosis-flags at NERR and RxD

NSTB	EN	INH	Mode	Event	NERR <sup>1)</sup>	RxD <sup>1)</sup>
1	1	$V_{BAT}$	Normal-operating	No failure detected	1	“Low”: bus Dominant, “High”: bus recessive
				<ul style="list-style-type: none"> <li>• <math>V_{CC}</math> undervoltage</li> <li>• Overtemperature</li> <li>• TxD time-out</li> <li>• RxD recessive clamping</li> </ul>	0	
1	0	$V_{BAT}$	Receive-only	No failure detected	1	“Low”: bus Dominant, “High”: bus recessive
				<ul style="list-style-type: none"> <li>• Power-Up-Flag<sup>2)</sup> OR</li> <li>• <math>V_{CC}</math> undervoltage</li> </ul>	0	
0	0	$V_{BAT}$	Stand-by	WUP detected	0	0
				LWU detected	1	0
				No Wake-up event detected	1	1
0	0	High-Z	Sleep	No Wake-up event detected	1	1
				No Wake-up event detected <sup>3)</sup>	0	0

1) Only valid if  $V_{IO}$  is in the functional range.

2) Power-Up-Flag only available if  $V_{BAT}$  or  $V_{CC}$  is in the functional range for at least  $t_{PON}$ . Power-Up-Flag will be cleared once entering Normal-operating Mode.

3) Valid if  $V_{IO} = 0 V$ .

# TLT9252VLC

## High-Speed CAN FD Transceiver

### Diagnosis-flags at NERR and RxD

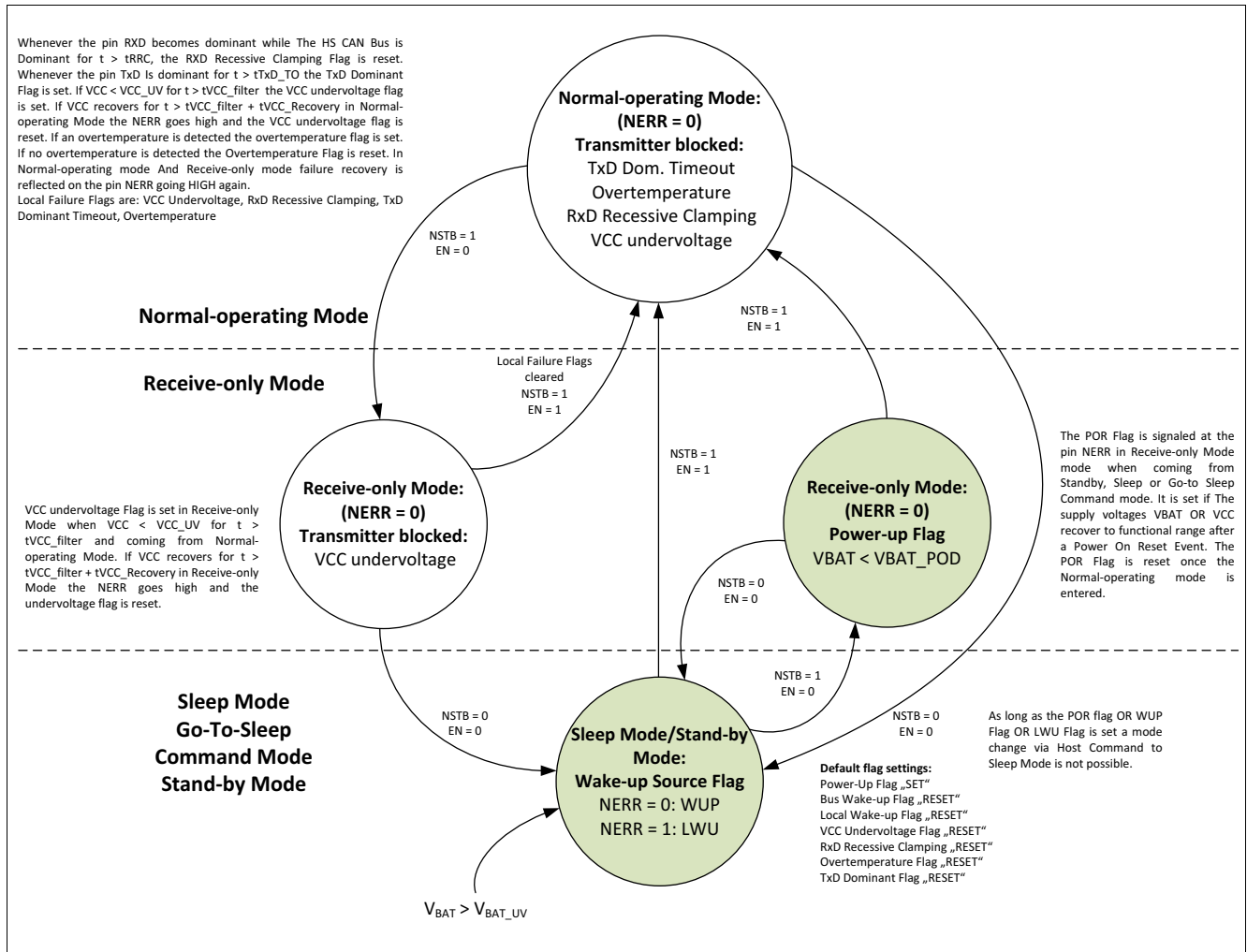

Figure 29 Diagnosis flowchart

# TLT9252VLC

## High-Speed CAN FD Transceiver

### Electrical characteristics

## 9 Electrical characteristics

The electrical characteristics are specified in the defined temperature range. Beyond this temperature range and below the absolute maximum rating the TLT9252VLC operates as described in the circuit description, parameter deviation is possible.

### 9.1 General timing parameter

**Table 8** General timing parameter

$4.5\text{ V} < V_{CC} < 5.5\text{ V}$ ;  $3.0\text{ V} < V_{IO} < 5.5\text{ V}$ ;  $5.5\text{ V} < V_{BAT} < 40\text{ V}$ ;  $R_L = 60\ \Omega$ ;  $-40^\circ\text{C} < T_J < 150^\circ\text{C}$ ;  
all voltages with respect to ground, positive current flowing into pin (unless otherwise specified)

Parameter	Symbol	Values			Unit	Note or Test Condition	Number
		Min.	Typ.	Max.			
Power-up delay time	$t_{PON}$	–	–	500	$\mu\text{s}$	See <a href="#">Figure 20</a>	P_9.1.1
Delay time for mode change	$t_{Mode}$	–	–	20	$\mu\text{s}$	–	P_9.1.2
CAN bus silence time-out	$t_{Silence}$	0.6	0.9	1.2	s	–	P_9.1.3
Min. hold time in Go-to-Sleep command	$t_{Sleep}$	10	25	50	$\mu\text{s}$	See <a href="#">Figure 10</a>	P_9.1.4
RxD Recessive Clamping detection time	$t_{RRC}$	–	1.2	1.8	$\mu\text{s}$	See <a href="#">Figure 28</a>	P_9.1.5
RxD Recessive Clamping indication delay	$t_{RRC\_NERR}$	–	–	1	$\mu\text{s}$	See <a href="#">Figure 28</a>	P_9.1.6

### 9.2 Power supply interface

#### 9.2.1 Current consumptions

**Table 9** Current consumptions

$4.5\text{ V} < V_{CC} < 5.5\text{ V}$ ;  $3.0\text{ V} < V_{IO} < 5.5\text{ V}$ ;  $5.5\text{ V} < V_{BAT} < 40\text{ V}$ ;  $R_L = 60\ \Omega$ ;  $-40^\circ\text{C} < T_J < 150^\circ\text{C}$ ;  
all voltages with respect to ground, positive current flowing into pin (unless otherwise specified)

Parameter	Symbol	Values			Unit	Note or Test Condition	Number
		Min.	Typ.	Max.			
<b>Normal-operating Mode</b>							
$V_{BAT}$ supply current	$I_{BAT\_NM}$	–	0.8	1.2	mA	INH = not connected	P_9.2.1
$V_{CC}$ supply current dominant bus signal	$I_{CC\_NM\_D}$	–	35	48	mA	–	P_9.2.2
$V_{CC}$ supply current recessive bus signal	$I_{CC\_NM\_R}$	–	1.0	4.0	mA	–	P_9.2.3
$V_{IO}$ supply current	$I_{IO\_NM}$	–	2.0	8.0	$\mu\text{A}$	steady state, TxD= $V_{IO}$	P_9.2.4

#### Receive-only Mode



## TLT9252VLC

### High-Speed CAN FD Transceiver

#### Electrical characteristics

**Table 9** Current consumptions (cont'd)

$4.5\text{ V} < V_{CC} < 5.5\text{ V}$ ;  $3.0\text{ V} < V_{IO} < 5.5\text{ V}$ ;  $5.5\text{ V} < V_{BAT} < 40\text{ V}$ ;  $R_L = 60\ \Omega$ ;  $-40^\circ\text{C} < T_J < 150^\circ\text{C}$ ;  
all voltages with respect to ground, positive current flowing into pin (unless otherwise specified)

Parameter	Symbol	Values			Unit	Note or Test Condition	Number
		Min.	Typ.	Max.			
$V_{BAT}$ supply current	$I_{BAT\_ROM}$	–	0.8	1.2	mA	INH = not connected	P_9.2.5
$V_{CC}$ supply current	$I_{CC\_ROM}$	–	33	50	$\mu\text{A}$	TxD= $V_{IO}$ , $V_{BAT} > 12\text{ V}$	P_9.2.6
$V_{IO}$ supply current	$I_{IO\_ROM}$	–	2.0	8.0	$\mu\text{A}$	steady state, TxD= $V_{IO}$	P_9.2.7

#### Stand-by Mode

$V_{BAT}$ supply current	$I_{BAT\_STB}$	–	22	50	$\mu\text{A}$	INH = n.c., $V_{BAT} < 18\text{ V}$ , $t_{\text{Silence}}$ expired, WAKE = GND	P_9.2.8
$V_{CC}$ supply current	$I_{CC\_STB}$	–	2.0	8.0	$\mu\text{A}$	TxD= $V_{IO}$ , $V_{BAT} > 12\text{ V}$	P_9.2.11
$V_{IO}$ supply current	$I_{IO\_STB}$	–	2.0	5.0	$\mu\text{A}$	TxD= $V_{IO}$	P_9.2.12

#### Sleep Mode

$V_{BAT}$ supply current	$I_{BAT\_SLP}$	–	12.0	25.0	$\mu\text{A}$	$V_{CC} = V_{IO} = 0\text{ V}$ , $V_{BAT} < 18\text{ V}$ , bus biasing = GND, INH = n.c.	P_9.2.13
$V_{BAT}$ supply current $T_J < 85^\circ\text{C}$	$I_{BAT\_SLP\_85}$	–	–	18.0	$\mu\text{A}$	$V_{CC} = V_{IO} = 0\text{ V}$ , INH = n.c., bus biasing = GND, $V_{BAT} < 18\text{ V}$ , $T_J < 85^\circ\text{C}$ <sup>1)</sup> ;	P_9.2.14
$V_{CC}$ supply current	$I_{CC\_SLP}$	–	0.5	5.0	$\mu\text{A}$	TxD= $V_{IO}$ , $V_{BAT} > 12\text{ V}$	P_9.2.16
$V_{IO}$ supply current	$I_{IO\_SLP}$	–	2.0	5.0	$\mu\text{A}$	TxD= $V_{IO}$ ;	P_9.2.17

1) Not subject to production test, specified by design

## 9.2.2 Undervoltage detection

**Table 10** Undervoltage detection

$4.5\text{ V} < V_{CC} < 5.5\text{ V}$ ;  $3.0\text{ V} < V_{IO} < 5.5\text{ V}$ ;  $5.5\text{ V} < V_{BAT} < 40\text{ V}$ ;  $R_L = 60\ \Omega$ ;  $-40^\circ\text{C} < T_J < 150^\circ\text{C}$ ;  
all voltages with respect to ground, positive current flowing into pin (unless otherwise specified)

Parameter	Symbol	Values			Unit	Note or Test Condition	Number
		Min.	Typ.	Max.			
<b>Undervoltage detection <math>V_{BAT}</math></b>							
Undervoltage detection threshold	$V_{BAT\_UV}$	4.8	5.1	5.5	V	–	P_9.2.18

## TLT9252VLC

### High-Speed CAN FD Transceiver

#### Electrical characteristics

**Table 10 Undervoltage detection** (cont'd)

$4.5\text{ V} < V_{CC} < 5.5\text{ V}$ ;  $3.0\text{ V} < V_{IO} < 5.5\text{ V}$ ;  $5.5\text{ V} < V_{BAT} < 40\text{ V}$ ;  $R_L = 60\ \Omega$ ;  $-40^\circ\text{C} < T_J < 150^\circ\text{C}$ ;  
all voltages with respect to ground, positive current flowing into pin (unless otherwise specified)

Parameter	Symbol	Values			Unit	Note or Test Condition	Number
		Min.	Typ.	Max.			
Power-down threshold	$V_{BAT\_POD}$	3.0	4.0	4.5	V	Falling edge, $V_{CC} = 0\text{V}$	P_9.2.20
$V_{BAT}$ undervoltage glitch filter	$t_{VBAT\_filter}$	–	–	50	$\mu\text{s}$	See <a href="#">Figure 20</a>	P_9.2.22

#### Undervoltage detection $V_{CC}$

Undervoltage detection threshold	$V_{CC\_UV}$	4.0	4.25	4.5	V	See <a href="#">Figure 22</a>	P_9.2.24
Undervoltage glitch filter	$t_{VCC\_filter}$	–	–	10	$\mu\text{s}$	See <a href="#">Figure 22</a>	P_9.2.27
Undervoltage recovery time	$t_{VCC\_RECOVERY}$	15	25	35	$\mu\text{s}$	See <a href="#">Figure 22</a>	P_9.2.28
Response time $V_{CC}$ for long-term undervoltage detection	$t_{VCC\_UV\_T}$	300	380	450	ms	See <a href="#">Figure 23</a>	P_9.2.29

#### Undervoltage detection $V_{IO}$

Undervoltage detection threshold	$V_{IO\_UV}$	2.4	2.65	3.0	V	See <a href="#">Figure 24</a>	P_9.2.30
Undervoltage glitch filter	$t_{VIO\_filter}$	–	–	10	$\mu\text{s}$	See <a href="#">Figure 24</a>	P_9.2.32
Response time $V_{IO}$ for long-term undervoltage detection	$t_{VIO\_UV\_T}$	300	380	450	ms	See <a href="#">Figure 25</a>	P_9.2.33

### 9.2.3 INH output

**Table 11 INH output**

$4.5\text{ V} < V_{CC} < 5.5\text{ V}$ ;  $3.0\text{ V} < V_{IO} < 5.5\text{ V}$ ;  $5.5\text{ V} < V_{BAT} < 40\text{ V}$ ;  $R_L = 60\ \Omega$ ;  $-40^\circ\text{C} < T_J < 150^\circ\text{C}$ ;  
all voltages with respect to ground, positive current flowing into pin (unless otherwise specified)

Parameter	Symbol	Values			Unit	Note or Test Condition	Number
		Min.	Typ.	Max.			

#### Analog output INH

Output voltage INH enabled	$V_{INH}$	$V_{BAT} - 0.8$	–	–	V	$I_{INH} = -0.2\text{ mA}$ , Normal-operating Mode, Receive-only Mode, Stand-by Mode, Go-to-Sleep command	P_9.2.34
Absolute leakage current	$I_{INH\_Leak}$	–5.0	–	–	$\mu\text{A}$	$V_{INH} = 0\text{ V}$ , Sleep Mode	P_9.2.35

## TLT9252VLC

### High-Speed CAN FD Transceiver

#### Electrical characteristics

### 9.3 EN, NSTB and NERR

**Table 12 EN, NSTB and NERR**

$4.5\text{ V} < V_{CC} < 5.5\text{ V}$ ;  $3.0\text{ V} < V_{IO} < 5.5\text{ V}$ ;  $5.5\text{ V} < V_{BAT} < 40\text{ V}$ ;  $R_L = 60\ \Omega$ ;  $-40^\circ\text{C} < T_J < 150^\circ\text{C}$ ;  
all voltages with respect to ground, positive current flowing into pin (unless otherwise specified)

Parameter	Symbol	Values			Unit	Note or Test Condition	Number
		Min.	Typ.	Max.			
<b>Mode control inputs EN, NSTB</b>							
“High” level input range	$V_{MODE\_H}$	$0.7 \times V_{IO}$	–	$V_{IO} + 0.3\text{V}$	V		P_9.3.1
“Low” level input range	$V_{MODE\_L}$	-0.3 V	–	$0.3 \times V_{IO}$	V		P_9.3.2
“High” level input current	$I_{MODE\_H}$	20	–	220	$\mu\text{A}$	$V_{MODE} = V_{IO}$	P_9.3.3
“Low” level input current	$I_{MODE\_L}$	-2.0	–	2.0	$\mu\text{A}$	$V_{MODE} = 0\text{ V}$	P_9.3.4
<b>Diagnosis output NERR</b>							
“High” level output current	$I_{NERR\_H}$	–	-4.0	-1.0	mA	$V_{NERR} = V_{IO} - 0.4\text{ V}$	P_9.3.5
“Low” level output current	$I_{NERR\_L}$	1.0	4.0	–	mA	$V_{NERR} = 0.4\text{ V}$	P_9.3.6

### 9.4 CAN controller interface

**Table 13 CAN controller interface**

$4.5\text{ V} < V_{CC} < 5.5\text{ V}$ ;  $3.0\text{ V} < V_{IO} < 5.5\text{ V}$ ;  $5.5\text{ V} < V_{BAT} < 40\text{ V}$ ;  $R_L = 60\ \Omega$ ;  $-40^\circ\text{C} < T_J < 150^\circ\text{C}$ ;  
all voltages with respect to ground, positive current flowing into pin (unless otherwise specified)

Parameter	Symbol	Values			Unit	Note or Test Condition	Number
		Min.	Typ.	Max.			
<b>Receiver output RxD</b>							
“High” level output current	$I_{RXD\_H}$	–	-4.0	-1.0	mA	$V_{RXD} = V_{IO} - 0.4\text{ V}$ , $V_{Diff} < 0.5\text{ V}$	P_9.4.1
“Low” level output current	$I_{RXD\_L}$	1.0	4.0	–	mA	$V_{RXD} = 0.4\text{ V}$ , $V_{Diff} > 0.9\text{ V}$	P_9.4.2
<b>Transmitter input TxD</b>							
“High” level input voltage threshold	$V_{TXD\_H}$	–	$0.5 \times V_{IO}$	$0.7 \times V_{IO}$	V	Recessive state	P_9.4.4
“Low” level input voltage threshold	$V_{TXD\_L}$	$0.3 \times V_{IO}$	$0.4 \times V_{IO}$	–	V	Dominant state	P_9.4.5
“High” level input current	$I_{TXD\_H}$	-2.0	–	2.0	$\mu\text{A}$	$V_{TXD} = V_{IO}$	P_9.4.7
“Low” level input current	$I_{TXD\_L}$	-200	–	-20.0	$\mu\text{A}$	$V_{TXD} = 0\text{ V}$	P_9.4.8
TxD permanent dominant time-out	$t_{TXD\_TO}$	1	2.45	4	ms	Normal-operating Mode, see <a href="#">Figure 26</a>	P_9.4.9
Input capacitance	$C_{TXD}$	–	–	10	pF	1)	P_9.4.10

1) Not subject to production test, specified by design.

# TLT9252VLC

## High-Speed CAN FD Transceiver

### Electrical characteristics

#### 9.5 Transmitter

**Table 14 Transmitter**

$4.5\text{ V} < V_{CC} < 5.5\text{ V}$ ;  $3.0\text{ V} < V_{IO} < 5.5\text{ V}$ ;  $5.5\text{ V} < V_{BAT} < 40\text{ V}$ ;  $R_L = 60\ \Omega$ ;  $-40^\circ\text{C} < T_J < 150^\circ\text{C}$ ;  
all voltages with respect to ground, positive current flowing into pin (unless otherwise specified)

Parameter	Symbol	Values			Unit	Note or Test Condition	Number
		Min.	Typ.	Max.			
<b>Bus transmitter</b>							
CANH, CANL recessive output voltage	$V_{CANL/H}$	2.0	2.5	3.0	V	Normal-operating Mode, Receive-only Mode, $V_{TXD} = V_{IO}$ , No load	P_9.5.1
CANH, CANL recessive output voltage difference	$V_{Diff\_R\_NM} = V_{CANH} - V_{CANL}$	-50	-	50	mV	$V_{TXD} = V_{IO}$ , No load	P_9.5.2
CANH dominant output voltage Normal-operating Mode	$V_{CANH}$	2.75	-	4.5	V	$V_{TXD} = 0\text{ V}$ , $50\ \Omega < R_L < 65\ \Omega$ , $4.75\text{ V} < V_{CC} < 5.25$	P_9.5.3
CANL dominant output voltage Normal-operating Mode	$V_{CANL}$	0.5	-	2.25	V	$V_{TXD} = 0\text{ V}$ , $50\ \Omega < R_L < 65\ \Omega$ , $4.75\text{ V} < V_{CC} < 5.25$	P_9.5.4
CANH, CANL dominant output voltage difference: $V_{Diff\_D} = V_{CANH} - V_{CANL}$ Normal-operating Mode	$V_{Diff\_D}$	1.5	2.0	2.5	V	$V_{TXD} = 0\text{ V}$ , $50\ \Omega < R_L < 65\ \Omega$ , $4.75\text{ V} < V_{CC} < 5.25$	P_9.5.5
CANH, CANL dominant output voltage difference extended bus load $V_{Diff\_D} = V_{CANH} - V_{CANL}$ Normal-operating Mode	$V_{Diff\_D\_EXT\_BL}$	1.4	-	3.3	V	$V_{TXD} = 0\text{ V}$ , $R_L = 45\ \Omega < R_L < 70\ \Omega$ , $4.75\text{ V} < V_{CC} < 5.25$	P_9.5.6
CANH, CANL dominant output voltage difference high extended bus load Normal-operating mode $V_{Diff} = V_{CANH} - V_{CANL}$	$V_{Diff\_D\_HEXT\_BL}$	1.5	-	5.0	V	$V_{TXD} = 0\text{ V}$ , $R_L = 2240\ \Omega^1)$ , $4.75\text{ V} < V_{CC} < 5.25$ , static behavior	P_9.5.7
CANH, CANL recessive output voltage Sleep Mode	$V_{CANL\_H}$	-0.1	-	0.1	V	No load	P_9.5.8
CANH, CANL recessive output voltage difference Sleep Mode	$V_{Diff\_SLP}$	-0.2	-	0.2	V	No load	P_9.5.9
Driver symmetry $V_{SYM} = (V_{CANH} + V_{CANL})/V_{CC}$	$V_{SYM}$	0.9	1.0	1.1	-	$R_L = 60\ \Omega$ , $C_1 = 4.7\text{ nF}$ <sup>1)2)</sup>	P_9.5.10

## TLT9252VLC

### High-Speed CAN FD Transceiver

#### Electrical characteristics

**Table 14 Transmitter** (cont'd)

4.5 V <  $V_{CC}$  < 5.5 V; 3.0 V <  $V_{IO}$  < 5.5 V; 5.5 V <  $V_{BAT}$  < 40 V;  $R_L = 60 \Omega$ ;  $-40^\circ\text{C} < T_J < 150^\circ\text{C}$ ;  
all voltages with respect to ground, positive current flowing into pin (unless otherwise specified)

Parameter	Symbol	Values			Unit	Note or Test Condition	Number
		Min.	Typ.	Max.			
CANH short circuit current	$I_{CANHSC}$	-115	-75	-40	mA	$V_{CANHshort} = -3 \text{ V}$ , $t < t_{TXD\_TO}$ , $V_{TXD} = 0 \text{ V}$ , $V_{CC} = 5 \text{ V}$	P_9.5.11
CANL short circuit current	$I_{CANLSC}$	40	75	115	mA	$V_{CANLshort} = 18 \text{ V}$ , $t < t_{TXD\_TO}$ , $V_{TXD} = 0 \text{ V}$ , $V_{CC} = 5 \text{ V}$	P_9.5.12
Leakage current CANH	$I_{CANH\_Ik}$	-5	-	5	$\mu\text{A}$	$V_{CC} = V_{BAT} = V_{IO} = 0 \text{ V}^{3)}$ , $0 \text{ V} < V_{CANH} \leq 5 \text{ V}$ , $V_{CANH} = V_{CANL}$	P_9.5.14
Leakage current CANL	$I_{CANL\_Ik}$	-5	-	5	$\mu\text{A}$	$V_{CC} = V_{BAT} = V_{IO} = 0 \text{ V}^{3)}$ , $0 \text{ V} < V_{CANL} \leq 5 \text{ V}$ , $V_{CANH} = V_{CANL}$	P_9.5.15
CANH, CANL output voltage difference slope, recessive to dominant	$V_{diff\_slope\_rd}$	-	-	70	V/ $\mu\text{s}$	<sup>1)</sup> 30% to 70% of measured differential bus voltage, $C_2 = 100 \text{ pF}$ , $R_L = 60 \Omega$ , $4.75 \text{ V} < V_{CC} < 5.25 \text{ V}$	P_9.5.16
CANH, CANL output voltage difference slope, dominant to recessive	$V_{diff\_slope\_dr}$	-	-	70	V/ $\mu\text{s}$	<sup>1)</sup> 30% to 70% of measured differential bus voltage, $C_2 = 100 \text{ pF}$ , $R_L = 60 \Omega$ , $4.75 \text{ V} < V_{CC} < 5.25 \text{ V}$	P_9.5.17

1) Not subject to production test, specified by design.

2)  $V_{SYM}$  shall be observed during dominant and recessive state and also during the transition from dominant to recessive and vice versa, while TxD is stimulated by a square wave signal with a frequency of 1 MHz.

3) Additional requirement  $V_{IO} = V_{CC}$  connected via 47 k $\Omega$  to GND.

## 9.6 Receiver

**Table 15 Receiver**

4.5 V <  $V_{CC}$  < 5.5 V; 3.0 V <  $V_{IO}$  < 5.5 V; 5.5 V <  $V_{BAT}$  < 40 V;  $R_L = 60 \Omega$ ;  $t_{Bit(min)} = 500 \text{ ns}$ ;  $t_{Bit(Flash)} = 200 \text{ ns}$ ;  
 $-40^\circ\text{C} < T_J < 150^\circ\text{C}$ ;

all voltages with respect to ground, positive current flowing into pin (unless otherwise specified)

Parameter	Symbol	Values			Unit	Note or Test Condition	Number
		Min.	Typ.	Max.			
<b>Bus receiver</b>							
Common mode range	$V_{CMR}$	-12	-	12	V	-	P_9.6.1

## TLT9252VLC

### High-Speed CAN FD Transceiver

#### Electrical characteristics

**Table 15 Receiver** (cont'd)

$4.5\text{ V} < V_{CC} < 5.5\text{ V}$ ;  $3.0\text{ V} < V_{IO} < 5.5\text{ V}$ ;  $5.5\text{ V} < V_{BAT} < 40\text{ V}$ ;  $R_L = 60\ \Omega$ ;  $t_{\text{Bit}(\text{min})} = 500\text{ ns}$ ;  $t_{\text{Bit}(\text{Flash})} = 200\text{ ns}$ ;  
 $-40^\circ\text{C} < T_J < 150^\circ\text{C}$ ;

all voltages with respect to ground, positive current flowing into pin (unless otherwise specified)

Parameter	Symbol	Values			Unit	Note or Test Condition	Number
		Min.	Typ.	Max.			
Differential receiver threshold dominant Normal-operating Mode Receive-only Mode	$V_{\text{Diff}_D}$	–	–	0.9	V	$V_{\text{CMR}}$	P_9.6.2
Differential range dominant Normal-operating Mode Receive-only Mode	$V_{\text{Diff}_D\text{Range}}$	0.9	–	8.0	V	$V_{\text{CMR}}^{1)}$	P_9.6.3
Differential receiver threshold recessive Normal-operating Mode Receive-only Mode	$V_{\text{Diff}_R}$	0.5	–	–	V	$V_{\text{CMR}}$	P_9.6.4
Differential range recessive Normal-operating Mode, Receive-only Mode	$V_{\text{Diff}_R\text{Range}}$	-3.0	–	0.5	V	$V_{\text{CMR}}^{1)}$	P_9.6.5
Differential receiver hysteresis Normal-operating Mode, Receive-only Mode	$V_{\text{Diff}_\text{Hys}}$	–	30	–	mV	$V_{\text{CMR}}^{1)}$	P_9.6.6
Single ended internal resistance	$R_{\text{CAN}_H}$ , $R_{\text{CAN}_L}$	6	–	50	k $\Omega$	Recessive state $-2\text{ V} < V_{\text{CANH,L}} < 7\text{ V}$	P_9.6.7
Input resistance deviation between CANH and CANL	$\Delta R_i$	-3.0	–	3.0	%	Recessive state $V_{\text{CANH}} = V_{\text{CANL}} = V_{\text{CC}} = 5\text{ V}$	P_9.6.8
Differential internal resistance	$R_{\text{Diff}}$	12	–	100	k $\Omega$	Recessive state $-2\text{ V} < V_{\text{CANH,L}} < 7\text{ V}$	P_9.6.9
Input capacitance CANH, CANL versus GND	$C_{\text{In}}$	–	20	40	pF	<sup>2)</sup> Recessive state	P_9.6.10
Differential input capacitance	$C_{\text{InDiff}}$	–	10	20	pF	<sup>2)</sup> Recessive state	P_9.6.11

1) Not subject to production test, specified by design.

2) Not subject to production test, specified by design, S2P-Method,  $f = 10\text{ MHz}$ .

## TLT9252VLC

### High-Speed CAN FD Transceiver

#### Electrical characteristics

### 9.7 Dynamic transceiver parameter

**Table 16 Propagation delay and CAN FD parameters**

$4.5\text{ V} < V_{CC} < 5.5\text{ V}$ ;  $3.0\text{ V} < V_{IO} < 5.5\text{ V}$ ;  $5.5\text{ V} < V_{BAT} < 40\text{ V}$ ;  $R_L = 60\ \Omega$ ;  $t_{\text{Bit}(\text{min})} = 500\text{ ns}$ ;  $t_{\text{Bit}(\text{Flash})} = 200\text{ ns}$ ;  
 $-40^\circ\text{C} < T_J < 150^\circ\text{C}$ ;

all voltages with respect to ground, positive current flowing into pin (unless otherwise specified)

Parameter	Symbol	Values			Unit	Note or Test Condition	Number
		Min.	Typ.	Max.			
<b>Propagation delay characteristic</b>							
Propagation delay, TxD to RxD	$t_{\text{Loop}}$	80	175	215	ns	$C_L = 100\text{ pF}$ , $C_{\text{RXD}} = 15\text{ pF}$ , see <a href="#">Figure 31</a>	P_9.7.1
Received recessive bit width at 2 MBit/s	$t_{\text{Bit}(\text{RxD})\_2\text{M}}$	400	500	550	ns	$C_L = 100\text{ pF}$ , $C_{\text{RXD}} = 15\text{ pF}$ , $t_{\text{Bit}} = 500\text{ ns}$ , see <a href="#">Figure 32</a>	P_9.7.6
Received recessive bit width at 5 MBit/s	$t_{\text{Bit}(\text{RxD})\_5\text{M}}$	120	200	220	ns	$C_L = 100\text{ pF}$ , $C_{\text{RXD}} = 15\text{ pF}$ , $t_{\text{Bit}} = 200\text{ ns}$ , see <a href="#">Figure 32</a>	P_9.7.7
Transmitted recessive bit width at 2 MBit/s	$t_{\text{Bit}(\text{Bus})\_2\text{M}}$	435	500	530	ns	$C_L = 100\text{ pF}$ , $C_{\text{RXD}} = 15\text{ pF}$ , $t_{\text{Bit}} = 500\text{ ns}$ (see <a href="#">Figure 32</a> )	P_9.7.8
Transmitted recessive bit width at 5 MBit/s	$t_{\text{Bit}(\text{Bus})\_5\text{M}}$	155	200	210	ns	$C_L = 100\text{ pF}$ , $C_{\text{RXD}} = 15\text{ pF}$ , $t_{\text{Bit}} = 200\text{ ns}$ ; (see <a href="#">Figure 32</a> )	P_9.7.9
Receiver timing symmetry at 2 MBit/s $\Delta t_{\text{Rec}_2\text{M}} = t_{\text{Bit}(\text{RxD})\_2\text{M}} - t_{\text{Bit}(\text{Bus})\_2\text{M}}$	$\Delta t_{\text{Rec}_2\text{M}}$	-65		40	ns	$C_L = 100\text{ pF}$ , $C_{\text{RXD}} = 15\text{ pF}$ , $t_{\text{Bit}} = 500\text{ ns}$ , see <a href="#">Figure 32</a>	P_9.7.10
Receiver timing symmetry at 5 MBit/s $\Delta t_{\text{Rec}_5\text{M}} = t_{\text{Bit}(\text{RxD})\_5\text{M}} - t_{\text{Bit}(\text{Bus})\_5\text{M}}$	$\Delta t_{\text{Rec}_5\text{M}}$	-45		15	ns	$C_L = 100\text{ pF}$ , $C_{\text{RXD}} = 15\text{ pF}$ , $t_{\text{Bit}} = 200\text{ ns}$ , see <a href="#">Figure 32</a>	P_9.7.11



# TLT9252VLC

## High-Speed CAN FD Transceiver

### Electrical characteristics

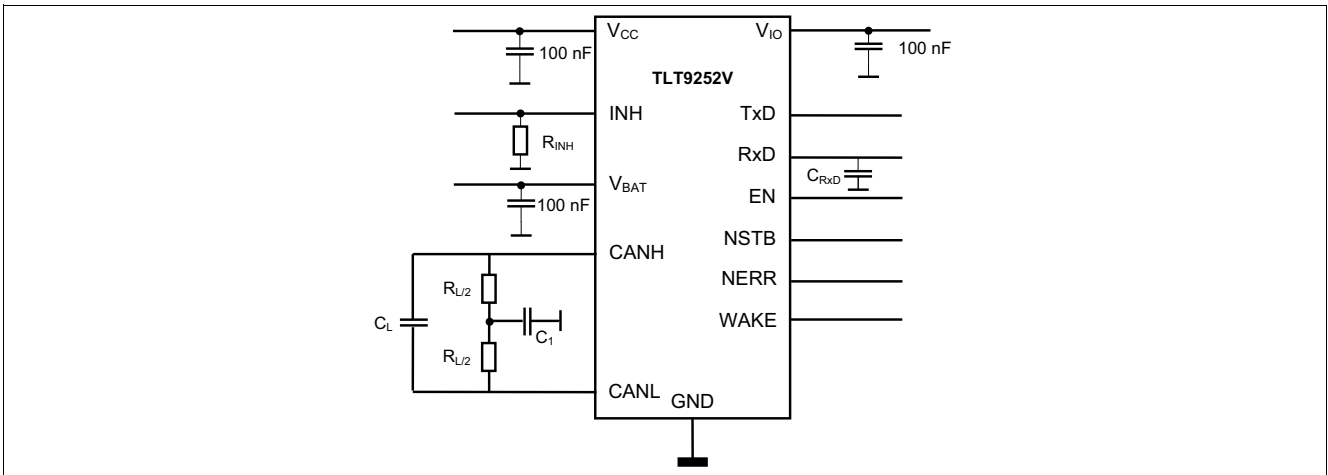

**Figure 30** Test circuit for dynamic characteristics

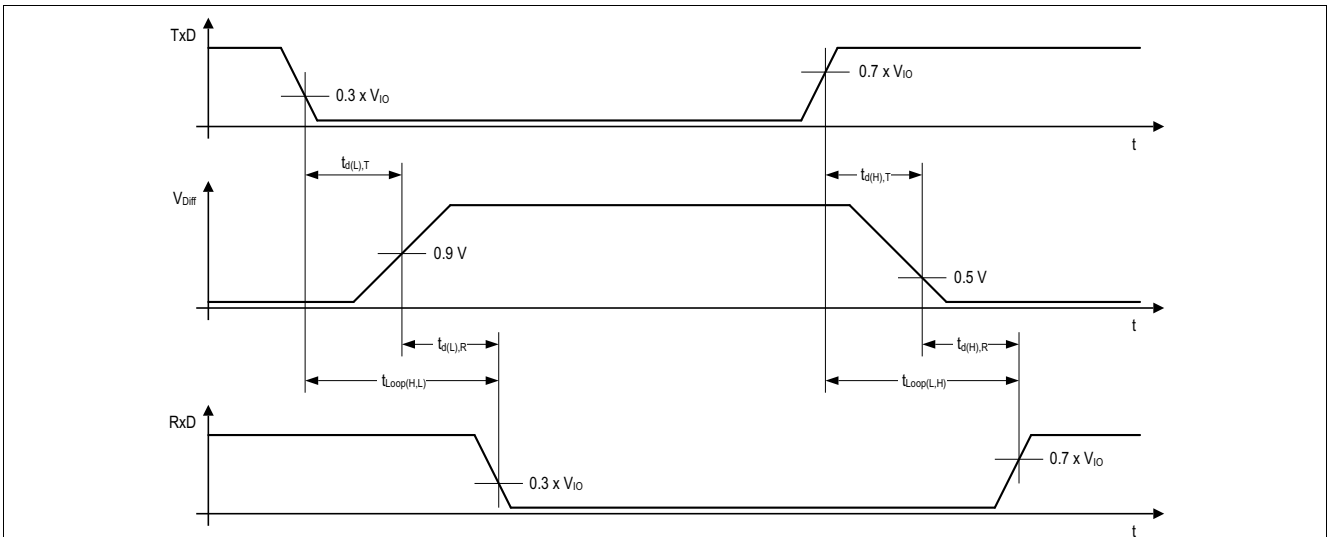

**Figure 31** Timing diagrams for dynamic characteristics

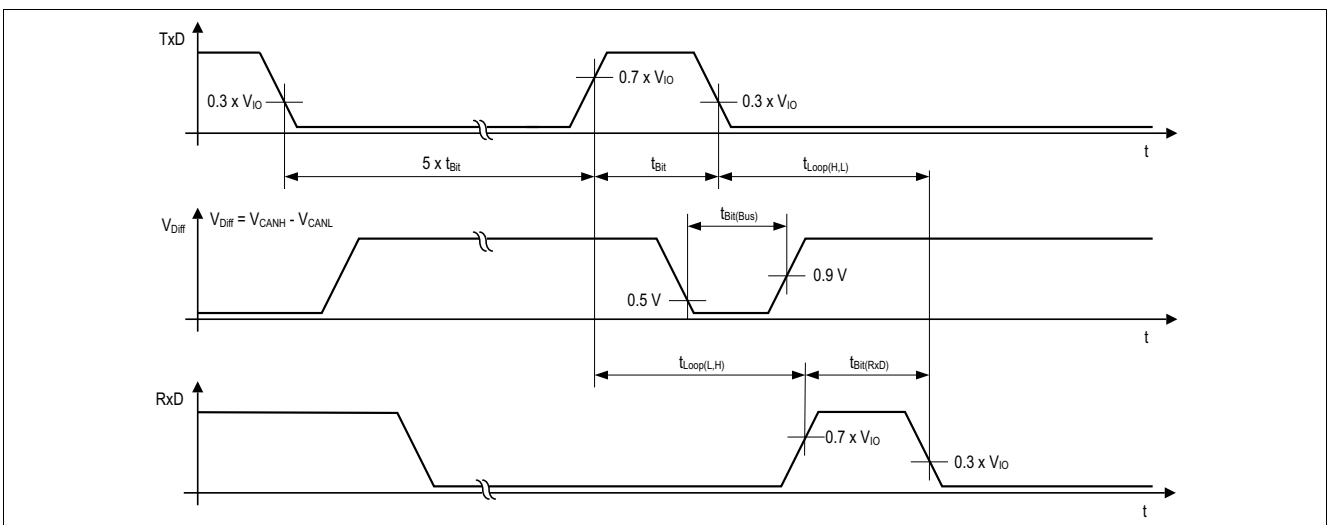

**Figure 32** Recessive bit time for five dominant bits followed by one recessive bit

**TLT9252VLC**  
**High-Speed CAN FD Transceiver**

**Electrical characteristics**

**9.8 Wake-up**

**9.8.1 General wake-up timings**

**Table 17 General wake-up timings**

4.5 V < V<sub>CC</sub> < 5.5 V; 3.0 V < V<sub>IO</sub> < 5.5 V; 5.5 V < V<sub>BAT</sub> < 40 V; R<sub>L</sub> = 60 Ω; -40°C < T<sub>J</sub> < 150°C; all voltages with respect to ground, positive current flowing into pin (unless otherwise specified)

Parameter	Symbol	Values			Unit	Note or Test Condition	Number
		Min.	Typ.	Max.			
INH wake-up delay time	t <sub>WU_INH</sub>	-	-	30.0	μs	V <sub>BAT</sub> = 14.0 V, R <sub>INH</sub> = 100 kΩ, see <a href="#">Figure 33</a>	P_9.8.1
Bias reaction time	t <sub>WU_Bias</sub>	-	-	100	μs	See <a href="#">Figure 33</a>	P_9.8.2

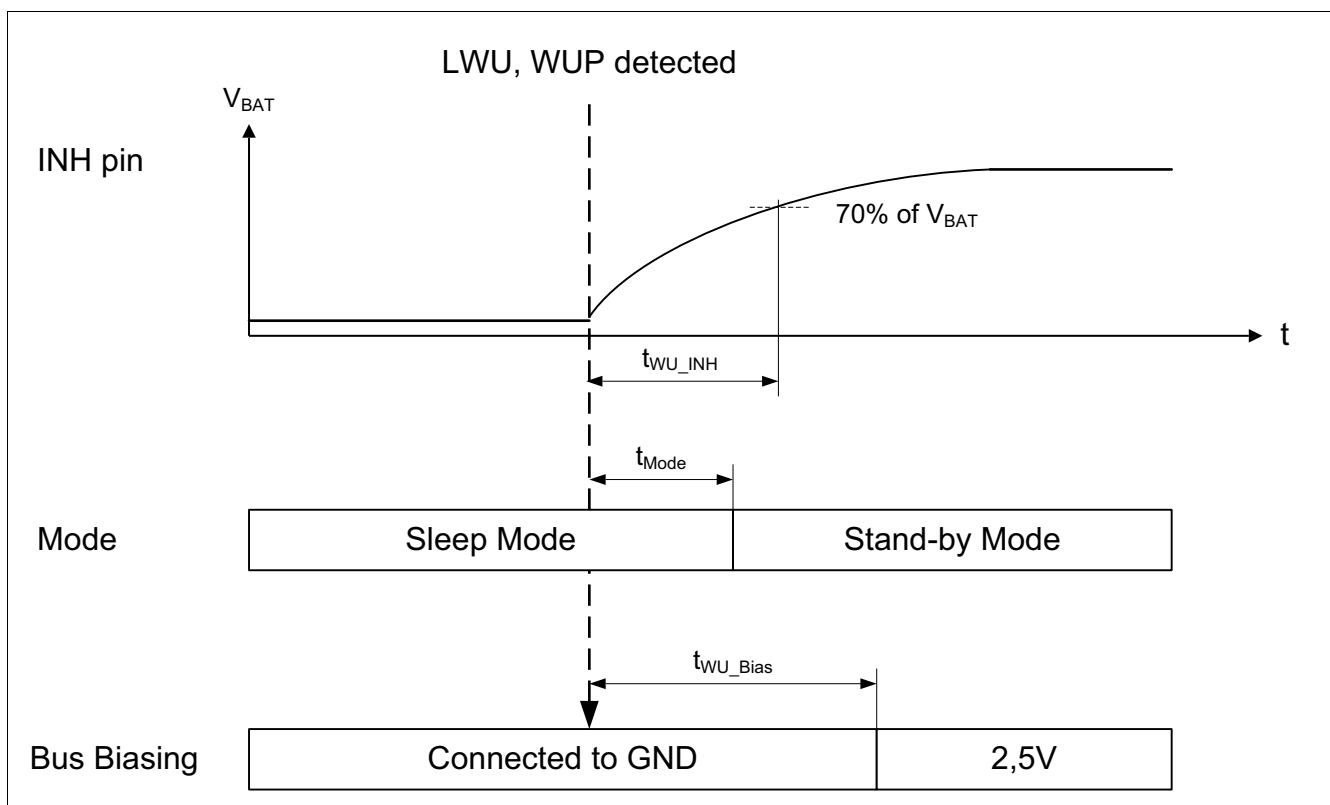

**Figure 33 Wake-up detection**

## TLT9252VLC

### High-Speed CAN FD Transceiver

#### Electrical characteristics

#### 9.8.2 WUP detection characteristics

**Table 18 WUP detection**

$4.75\text{ V} < V_{CC} < 5.25\text{ V}$ ;  $3.0\text{ V} < V_{IO} < 5.5\text{ V}$ ;  $5.5\text{ V} < V_{BAT} < 40\text{ V}$ ;  $R_L = 60\ \Omega$ ;  $-40^\circ\text{C} < T_J < 150^\circ\text{C}$ ;  
all voltages with respect to ground, positive current flowing into pin (unless otherwise specified)

Parameter	Symbol	Values			Unit	Note or Test Condition	Number
		Min.	Typ.	Max.			
Differential range dominant low power modes	$V_{\text{Diff\_D\_SLP\_Range}}$	1.15	–	8.0	V	$V_{\text{CMR}}^{1)}$	P_9.8.4
Differential input threshold dominant low power modes	$V_{\text{Diff\_D\_SLP}}$	–	–	1.15	V	$V_{\text{CMR}}$	P_9.8.5
+Differential range recessive low power modes	$V_{\text{Diff\_R\_SLP\_Range}}$	-3.0	–	0.4	V	$V_{\text{CMR}}^{1)}$	P_9.8.6
Differential input threshold recessive low power modes	$V_{\text{Diff\_R\_SLP}}$	0.4	–	–	V	$V_{\text{CMR}}$	P_9.8.7
CAN activity filter time	$t_{\text{Filter}}$	0.5	–	1.8	$\mu\text{s}$	Figure 14	P_9.8.9
Bus wake-up time-out	$t_{\text{WAKE}}$	0.8	–	10.0	ms	Figure 14	P_9.8.10
Bus wake-up delay time	$t_{\text{WU}}$	–	–	5.0	$\mu\text{s}$	Stand-by Mode, Figure 14	P_9.8.11

1) Not subject to production test, specified by design.

#### 9.8.3 Local Wake-Up

**Table 19 Local Wake-Up**

$4.75\text{ V} < V_{CC} < 5.5\text{ V}$ ;  $3.0\text{ V} < V_{IO} < 5.5\text{ V}$ ;  $5.5\text{ V} < V_{BAT} < 40\text{ V}$ ;  $R_L = 60\ \Omega$ ;  $-40^\circ\text{C} < T_J < 150^\circ\text{C}$ ;  
all voltages with respect to ground, positive current flowing into pin (unless otherwise specified)

Parameter	Symbol	Values			Unit	Note or Test Condition	Number
		Min.	Typ.	Max.			
Local Wake-Up detection threshold	$V_{\text{WAKE\_TH}}$	$0.35 \times V_{\text{BAT}}$	$0.5 \times V_{\text{BAT}}$	$0.65 \times V_{\text{BAT}}$	V	$5.5\text{ V} < V_{\text{BAT}} < 32\text{ V}$	P_9.8.12
Local Wake-Up detection threshold	$V_{\text{WAKE\_TH}}$	$0.25 \times V_{\text{BAT}}$	$0.5 \times V_{\text{BAT}}$	$0.75 \times V_{\text{BAT}}$	V	$32\text{ V} < V_{\text{BAT}} < 40\text{ V}$	P_9.8.13
“High” level input current (pull-up)	$I_{\text{WAKE\_H}}$	-20	-9	-2	$\mu\text{A}$		P_9.8.15
“Low” level input current (pull-down)	$I_{\text{WAKE\_L}}$	2	9	20	$\mu\text{A}$		P_9.8.16
Wake pulse filter time	$t_{\text{WAKE\_Filter}}$	10	25	70	$\mu\text{s}$	Figure 15	P_9.8.17

## TLT9252VLC

### High-Speed CAN FD Transceiver

#### Application information

## 10 Application information

### 10.1 ESD robustness according to IEC61000-4-2

Tests for ESD robustness according to IEC61000-4-2 “Gun test” (150 pF, 330  $\Omega$ ) have been performed. The results and test conditions are available in a separate test report.

**Table 20 ESD robustness according to IEC61000-4-2**

Performed Test	Result	Unit	Remarks
Electrostatic discharge voltage at pin CANH and CANL, $V_{BAT}$ , WAKE versus GND	$\geq +9$	kV	<sup>1)</sup> Positive pulse
Electrostatic discharge voltage at pin CANH and CANL, $V_{BAT}$ , WAKE versus GND	$\leq -9$	kV	<sup>1)</sup> Negative pulse

1) ESD susceptibility “ESD GUN” according to GIFT / ICT paper: “EMC Evaluation of CAN Transceivers, version 03/02/IEC TS62228”, section 4.3. (DIN EN61000-4-2).  
Tested by external test facility (IBEE Zwickau).

### 10.2 Voltage adaption to the microcontroller supply

To adapt the digital input and output levels of the TLT9252VLC to the I/O levels of the microcontroller, connect the power supply pin  $V_{IO}$  to the microcontroller voltage supply (see [Figure 34](#)).

*Note:* In case the digital supply voltage  $V_{IO}$  is not required in the application, connect the digital supply voltage  $V_{IO}$  to the transmitter supply  $V_{CC}$ .

# TLT9252VLC

## High-Speed CAN FD Transceiver

### Application information

### 10.3 Application example

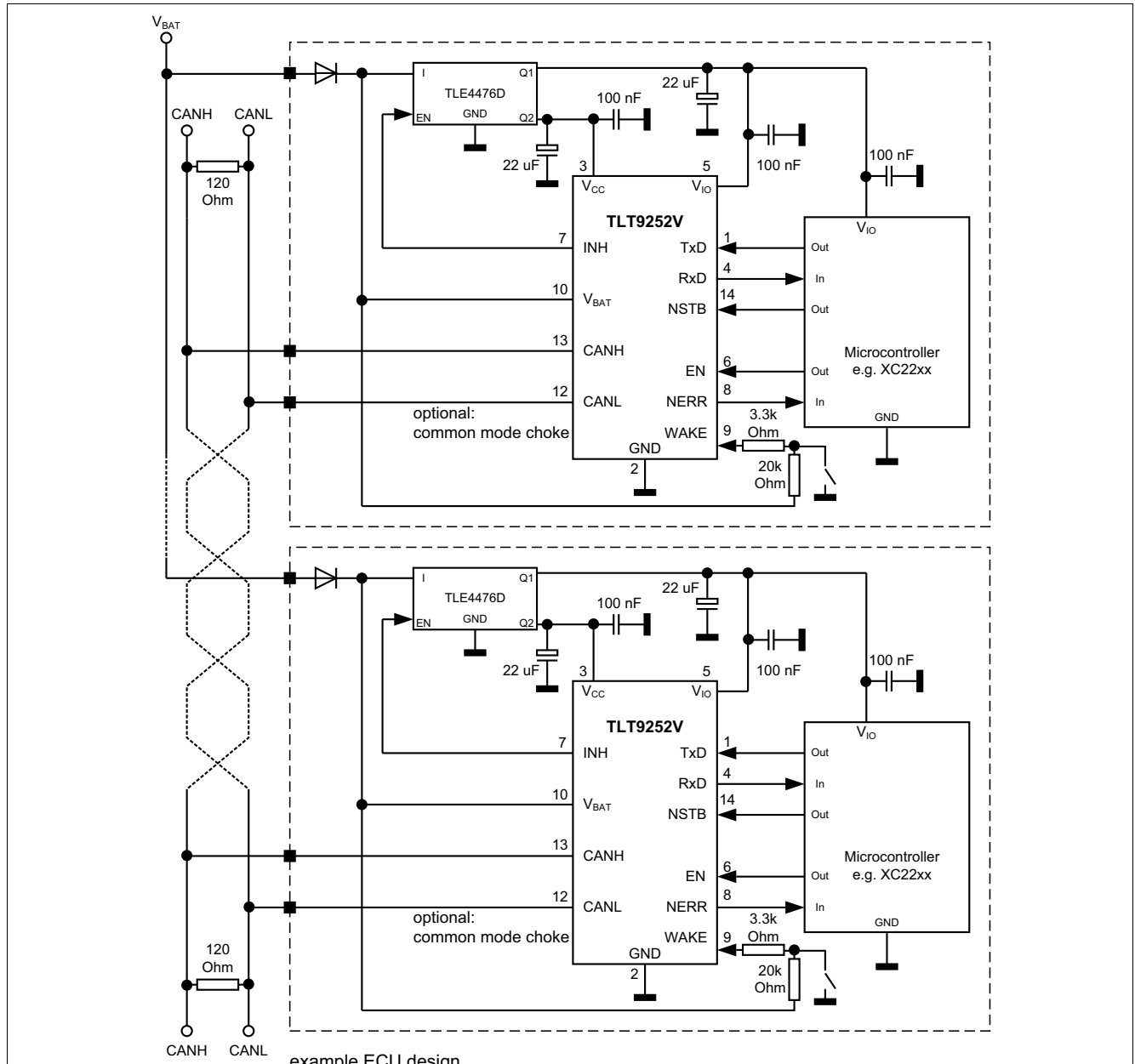

Figure 34 Application circuit

### 10.4 Further application information

- Please contact us for information regarding the pin FMEA.
- For further information you may visit: <http://www.infineon.com/>

# TLT9252VLC

## High-Speed CAN FD Transceiver

### Package outline

## 11 Package outline

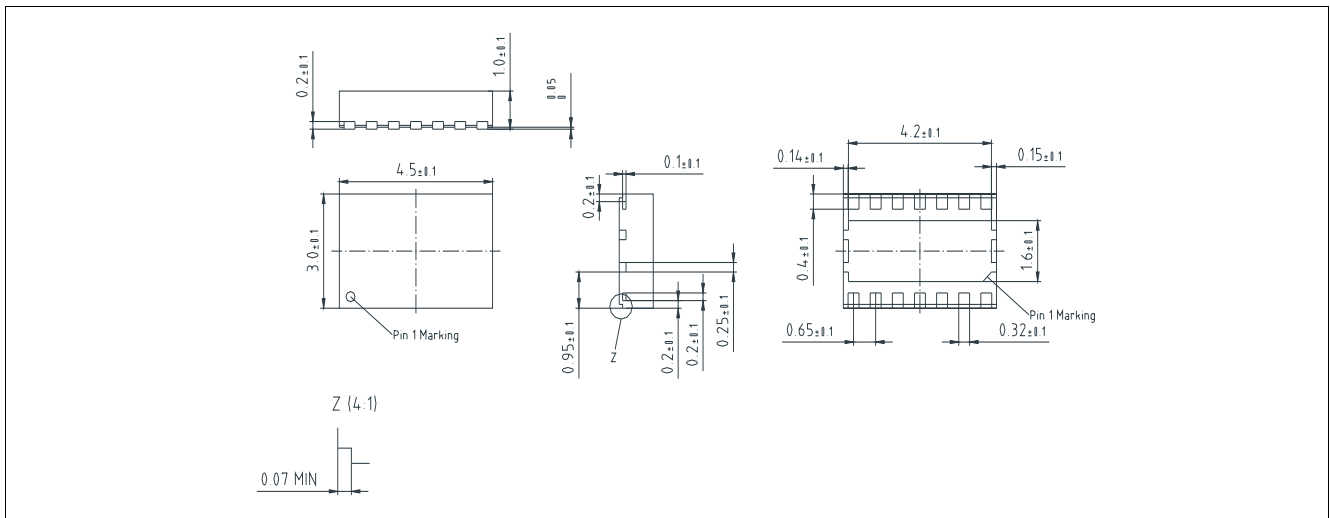

**Figure 35 PG-TSON-14**

### Green product (RoHS compliant)

To meet the world-wide customer requirements for environmentally friendly products and to be compliant with government regulations the device is available as a green product. Green products are RoHS-Compliant (i.e. Pb-free finish on leads and suitable for Pb-free soldering according to IPC/JEDEC J-STD-020).



## TLT9252VLC

### High-Speed CAN FD Transceiver

---

#### Revision history

## 12 Revision history

Revision	Date	Changes
1.0	2019-10-17	Initial datasheet



**Trademarks**

All referenced product or service names and trademarks are the property of their respective owners.

**Edition 2019-10-17**

**Published by**

**Infineon Technologies AG**

**81726 Munich, Germany**

**© 2019 Infineon Technologies AG.**

**All Rights Reserved.**

**Do you have a question about any aspect of this document?**

**Email: [erratum@infineon.com](mailto:erratum@infineon.com)**

**Document reference**

**Z8F66182131**

**IMPORTANT NOTICE**

The information given in this document shall in no event be regarded as a guarantee of conditions or characteristics ("Beschaffheitsgarantie").

With respect to any examples, hints or any typical values stated herein and/or any information regarding the application of the product, Infineon Technologies hereby disclaims any and all warranties and liabilities of any kind, including without limitation warranties of non-infringement of intellectual property rights of any third party.

In addition, any information given in this document is subject to customer's compliance with its obligations stated in this document and any applicable legal requirements, norms and standards concerning customer's products and any use of the product of Infineon Technologies in customer's applications.

The data contained in this document is exclusively intended for technically trained staff. It is the responsibility of customer's technical departments to evaluate the suitability of the product for the intended application and the completeness of the product information given in this document with respect to such application.

For further information on technology, delivery terms and conditions and prices, please contact the nearest Infineon Technologies Office ([www.infineon.com](http://www.infineon.com)).

**WARNINGS**

Due to technical requirements products may contain dangerous substances. For information on the types in question please contact your nearest Infineon Technologies office.

Except as otherwise explicitly approved by Infineon Technologies in a written document signed by authorized representatives of Infineon Technologies, Infineon Technologies' products may not be used in any applications where a failure of the product or any consequences of the use thereof can reasonably be expected to result in personal injury.

## OUR CERTIFICATE

DiGi provide top-quality products and perfect service for customer worldwide through standardization, technological innovation and continuous improvement. DiGi through third-party certification, we stricly control the quality of products and services. Welcome your RFQ to

Email: [Info@DiGi-Electronics.com](mailto:Info@DiGi-Electronics.com)



Tel: +00 852-30501935

RFQ Email: [Info@DiGi-Electronics.com](mailto:Info@DiGi-Electronics.com)

DiGi is a global authorized distributor of electronic components.