

IS62WV2568BLL-55TLI Datasheet

www.digi-electronics.com

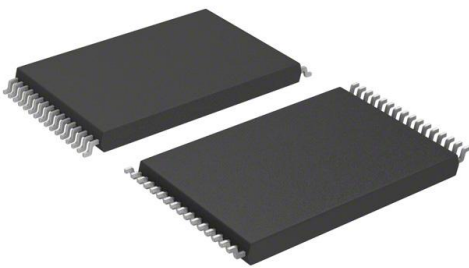

<https://www.DiGi-Electronics.com>

DiGi Electronics Part Number	IS62WV2568BLL-55TLI-DG
Manufacturer	ISSI, Integrated Silicon Solution Inc
Manufacturer Product Number	IS62WV2568BLL-55TLI
Description	IC SRAM 2MBIT PARALLEL 32TSOP I
Detailed Description	SRAM - Asynchronous Memory IC 2Mbit Parallel 55 ns 32-TSOP I

This model IS62WV2568BLL-55TLI is available at DiGi Electronics.

DiGi Electronics offers a global database of semiconductor and electronic component datasheets.

We welcome your inquiries regarding pricing, lead time, or other product-related questions.

 [Request a Quote](#)

 [Datasheet Search](#)



Tel: +00 852-30501935

RFQ Email: Info@DiGi-Electronics.com

DiGi is a global authorized distributor of electronic components.

Purchase and inquiry

Manufacturer Product Number:

IS62WV2568BLL-55TLI

Series:

-

DiGi-Electronics Programmable:

Not Verified

Memory Format:

SRAM

Memory Size:

2Mbit

Memory Interface:

Parallel

Access Time:

55 ns

Operating Temperature:

-40°C ~ 85°C (TA)

Package / Case:

32-TFSOP (0.724", 18.40mm Width)

Base Product Number:

IS62WV2568

Manufacturer:

ISSI, Integrated Silicon Solution Inc

Product Status:

Active

Memory Type:

Volatile

Technology:

SRAM - Asynchronous

Memory Organization:

256K x 8

Write Cycle Time - Word, Page:

55ns

Voltage - Supply:

2.5V ~ 3.6V

Mounting Type:

Surface Mount

Supplier Device Package:

32-TSOP I

Environmental & Export classification

RoHS Status:

ROHS3 Compliant

REACH Status:

REACH Unaffected

HTSUS:

8542.32.0041

Moisture Sensitivity Level (MSL):

3 (168 Hours)

ECCN:

3A991B2A



IS62WV2568ALL

IS62WV2568BLL

256K x 8 LOW VOLTAGE, ULTRA LOW POWER CMOS STATIC RAM

JANUARY 2013

FEATURES

- High-speed access time: 45ns, 55ns, 70ns
- CMOS low power operation
 - 36 mW (typical) operating
 - 9 μ W (typical) CMOS standby
- TTL compatible interface levels
- Single power supply
 - 1.65V--2.2V V_{CC} (62WV2568ALL)
 - 2.5V--3.6V V_{CC} (62WV2568BLL)
- Fully static operation: no clock or refresh required
- Three state outputs
- Industrial temperature available
- Lead-free available

DESCRIPTION

The *ISSI* IS62WV2568ALL / IS62WV2568BLL are high-speed, 2M bit static RAMs organized as 256K words by 8 bits. It is fabricated using *ISSI*'s high-performance CMOS technology. This highly reliable process coupled with innovative circuit design techniques, yields high-performance and low power consumption devices.

When $\overline{CS1}$ is HIGH (deselected) or when CS2 is LOW (deselected), the device assumes a standby mode at which the power dissipation can be reduced down with CMOS input levels.

Easy memory expansion is provided by using Chip Enable and Output Enable inputs. The active LOW Write Enable (\overline{WE}) controls both writing and reading of the memory.

The IS62WV2568ALL and IS62WV2568BLL are packaged in the JEDEC standard 32-pin TSOP (TYPE I), sTSOP (TYPE I), and 36-pin mini BGA.

FUNCTIONAL BLOCK DIAGRAM

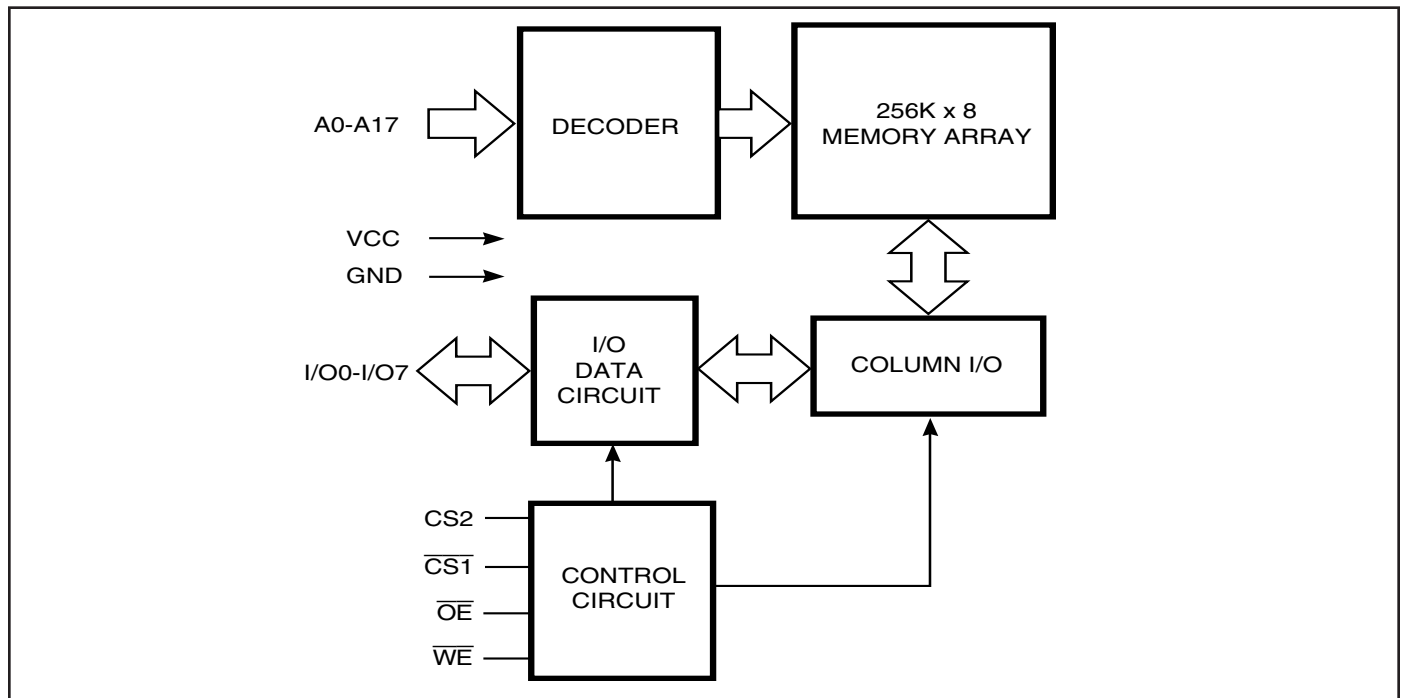

Copyright © 2013 Integrated Silicon Solution, Inc. All rights reserved. ISSI reserves the right to make changes to this specification and its products at any time without notice. ISSI assumes no liability arising out of the application or use of any information, products or services described herein. Customers are advised to obtain the latest version of this device specification before relying on any published information and before placing orders for products.



IS62WV2568ALL, IS62WV2568BLL

PIN DESCRIPTIONS

A0-A17	Address Inputs
$\overline{CS1}$	Chip Enable 1 Input
CS2	Chip Enable 2 Input
\overline{OE}	Output Enable Input
\overline{WE}	Write Enable Input
I/O0-I/O7	Input/Output
NC	No Connection
Vcc	Power
GND	Ground

PIN CONFIGURATION

36-pin mini BGA (B) (6mm x 8mm)

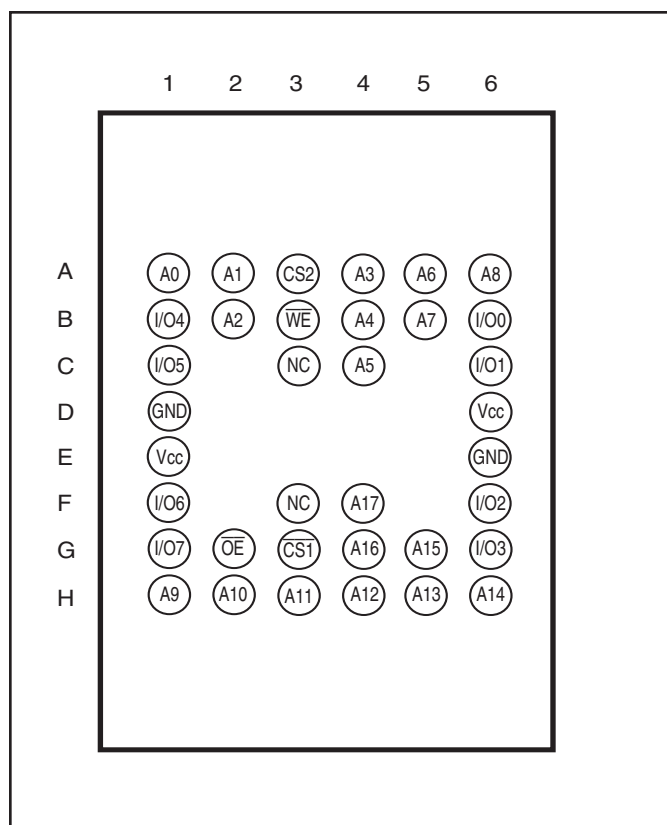

32-pin TSOP (TYPE I), sTSOP (TYPE I)

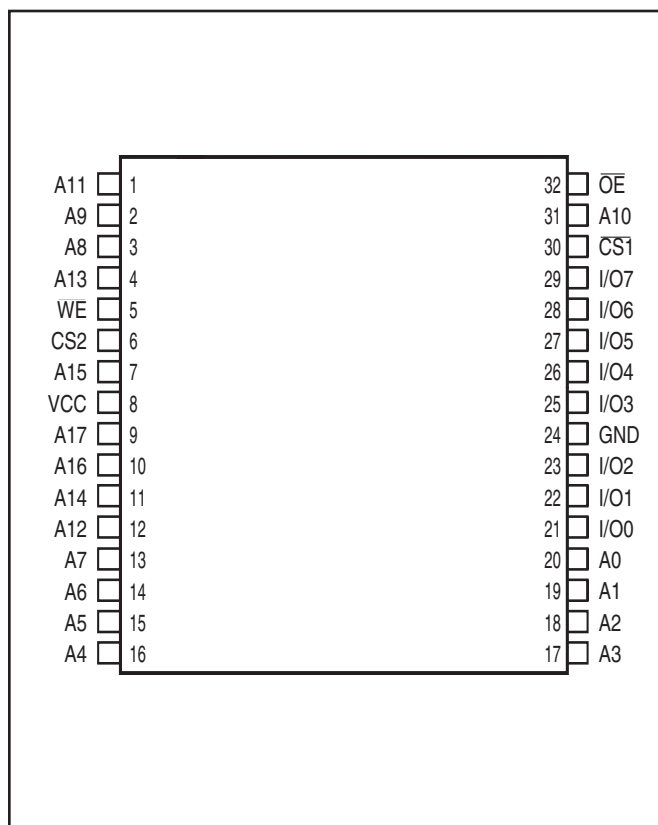



IS62WV2568ALL, IS62WV2568BLL

ABSOLUTE MAXIMUM RATINGS⁽¹⁾

Symbol	Parameter	Value	Unit
V _{TERM}	Terminal Voltage with Respect to GND	-0.2 to V _{CC} +0.3	V
T _{STG}	Storage Temperature	-65 to +150	°C
P _T	Power Dissipation	1.0	W

Note:

- Stress greater than those listed under ABSOLUTE MAXIMUM RATINGS may cause permanent damage to the device. This is a stress rating only and functional operation of the device at these or any other conditions above those indicated in the operational sections of this specification is not implied. Exposure to absolute maximum rating conditions for extended periods may affect reliability.

OPERATING RANGE (V_{CC})

Range	Ambient Temperature	IS62WV2568ALL	IS62WV2568BLL
Commercial	0°C to +70°C	1.65V - 2.2V	2.5V - 3.6V
Industrial	-40°C to +85°C	1.65V - 2.2V	2.5V - 3.6V

DC ELECTRICAL CHARACTERISTICS (Over Operating Range)

Symbol	Parameter	Test Conditions	V _{CC}	Min.	Max.	Unit
V _{OH}	Output HIGH Voltage	I _{OH} = -0.1 mA I _{OH} = -1 mA	1.65-2.2V	1.4	—	V
			2.5-3.6V	2.2	—	V
V _{OL}	Output LOW Voltage	I _{OL} = 0.1 mA I _{OL} = 2.1 mA	1.65-2.2V	—	0.2	V
			2.5-3.6V	—	0.4	V
V _{IH}	Input HIGH Voltage		1.65-2.2V	1.4	V _{CC} + 0.2	V
			2.5-3.6V	2.2	V _{CC} + 0.3	V
V _{IL} ⁽¹⁾	Input LOW Voltage		1.65-2.2V	-0.2	0.4	V
			2.5-3.6V	-0.2	0.6	V
I _{LI}	Input Leakage	GND ≤ V _{IN} ≤ V _{CC}		-1	1	μA
I _{LO}	Output Leakage	GND ≤ V _{OUT} ≤ V _{CC} , Outputs Disabled		-1	1	μA

Notes:

- Undershoot: -1.0V for pulse width less than 10ns. Not 100% tested.
- Overshoot: V_{DD} + 1.0V for pulse width less than 10ns. Not 100% tested.



IS62WV2568ALL, IS62WV2568BLL

CAPACITANCE⁽¹⁾

Symbol	Parameter	Conditions	Max.	Unit
C _{IN}	Input Capacitance	V _{IN} = 0V	8	pF
C _{OUT}	Input/Output Capacitance	V _{OUT} = 0V	10	pF

Note:

1. Tested initially and after any design or process changes that may affect these parameters.

AC TEST CONDITIONS

Parameter	62WV2568ALL (Unit)	62WV2568BLL (Unit)
Input Pulse Level	0.4V to V _{CC} -0.2V	0.4V to V _{CC} -0.3V
Input Rise and Fall Times	5 ns	5ns
Input and Output Timing and Reference Level	V _{REF}	V _{REF}
Output Load	See Figures 1 and 2	See Figures 1 and 2

	1.65-2.2V	2.5V - 3.6V
R1(Ω)	3070	3070
R2(Ω)	3150	3150
V _{REF}	0.9V	1.5V
V _{TM}	1.8V	2.8V

AC TEST LOADS

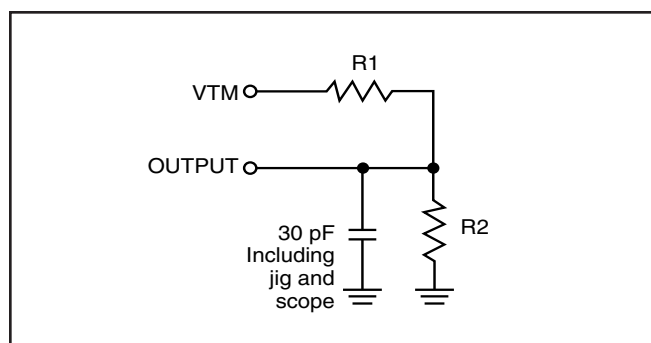

Figure 1

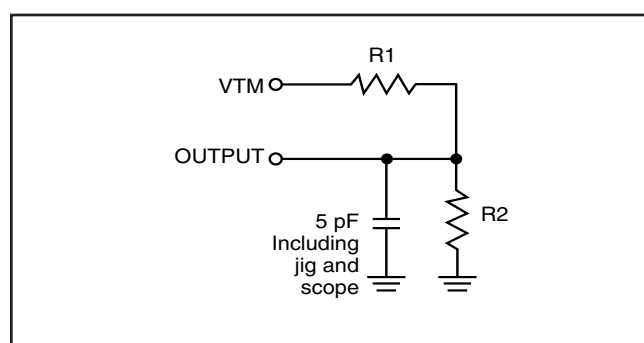

Figure 2



IS62WV2568ALL, IS62WV2568BLL

POWER SUPPLY CHARACTERISTICS⁽¹⁾ (Over Operating Range)

62WV2568ALL (1.65V - 2.2V)

Symbol	Parameter	Test Conditions		Max. 70ns	Unit
I _{CC}	V _{CC} Dynamic Operating Supply Current	V _{CC} = Max., I _{OUT} = 0 mA, f = f _{MAX}	Com. Ind.	15 15	mA
I _{CC1}	Operating Supply Current	V _{CC} = Max., I _{OUT} = 0 mA, f = 0	Com. Ind.	3 3	mA
I _{SB1}	TTL Standby Current (TTL Inputs)	V _{CC} = Max., V _{IN} = V _{IH} or V _{IL} , $\overline{CS1} = V_{IH}$, CS2 = V _{IL} , f = 1 MHz	Com. Ind.	0.3 0.3	mA
I _{SB2}	CMOS Standby Current (CMOS Inputs)	V _{CC} = Max., $\overline{CS1} \geq V_{CC} - 0.2V$, CS2 ≤ 0.2V, V _{IN} ≥ V _{CC} - 0.2V, or V _{IN} ≤ 0.2V, f = 0	Com. Ind.	5 10	μA

Note:

1. At f = f_{MAX}, address and data inputs are cycling at the maximum frequency, f = 0 means no input lines change.

POWER SUPPLY CHARACTERISTICS⁽¹⁾ (Over Operating Range)

62WV2568BLL (2.5V - 3.6V)

Symbol	Parameter	Test Conditions		Max. 45ns	Max. 55ns	Max. 70ns	Unit
I _{CC}	V _{CC} Dynamic Operating Supply Current	V _{CC} = Max., I _{OUT} = 0 mA, f = f _{MAX}	Com. Ind.	35 40	30 35	25 30	mA
I _{SB1}	TTL Standby Current (TTL Inputs)	V _{CC} = Max., V _{IN} = V _{IH} or V _{IL} , $\overline{CS1} = V_{IH}$, CS2 = V _{IL} , f = 1 MHz	Com. Ind.	0.3 0.3	0.3 0.3	0.3 0.3	mA
I _{SB2}	CMOS Standby Current (CMOS Inputs)	V _{CC} = Max., $\overline{CS1} \geq V_{CC} - 0.2V$, CS2 ≤ 0.2V, V _{IN} ≥ V _{CC} - 0.2V, or V _{IN} ≤ 0.2V, f = 0	Com. Ind.	10 10	10 10	10 10	μA

Note:

1. At f = f_{MAX}, address and data inputs are cycling at the maximum frequency, f = 0 means no input lines change.



IS62WV2568ALL, IS62WV2568BLL

READ CYCLE SWITCHING CHARACTERISTICS⁽¹⁾ (Over Operating Range)

Symbol	Parameter	45ns		55ns		70ns		Unit
		Min.	Max.	Min.	Max.	Min.	Max.	
t _{RC}	Read Cycle Time	45	—	55	—	70	—	ns
t _{AA}	Address Access Time	—	45	—	55	—	70	ns
t _{OHA}	Output Hold Time	10	—	10	—	10	—	ns
t _{ACS1} /t _{ACS2}	$\overline{CS1}/CS2$ Access Time	—	45	—	55	—	70	ns
t _{DOE}	\overline{OE} Access Time	—	20	—	25	—	35	ns
t _{HZOE} ⁽²⁾	\overline{OE} to High-Z Output	—	15	—	20	—	25	ns
t _{LZOE} ⁽²⁾	\overline{OE} to Low-Z Output	5	—	5	—	5	—	ns
t _{HZCS1} /t _{HZCS2} ⁽²⁾	$\overline{CS1}/CS2$ to High-Z Output	0	15	0	20	0	25	ns
t _{LZCS1} /t _{LZCS2} ⁽²⁾	$\overline{CS1}/CS2$ to Low-Z Output	10	—	10	—	10	—	ns

Notes:

1. Test conditions assume signal transition times of 5 ns or less, timing reference levels of 0.9V, input pulse levels of 0.4 to 1.4V and output loading specified in Figure 1.
2. Tested with the load in Figure 2. Transition is measured ± 500 mV from steady-state voltage. Not 100% tested.

AC WAVEFORMS

READ CYCLE NO. 1^(1,2) (Address Controlled) ($\overline{CS1} = \overline{OE} = V_{IL}$, $CS2 = \overline{WE} = V_{IH}$)

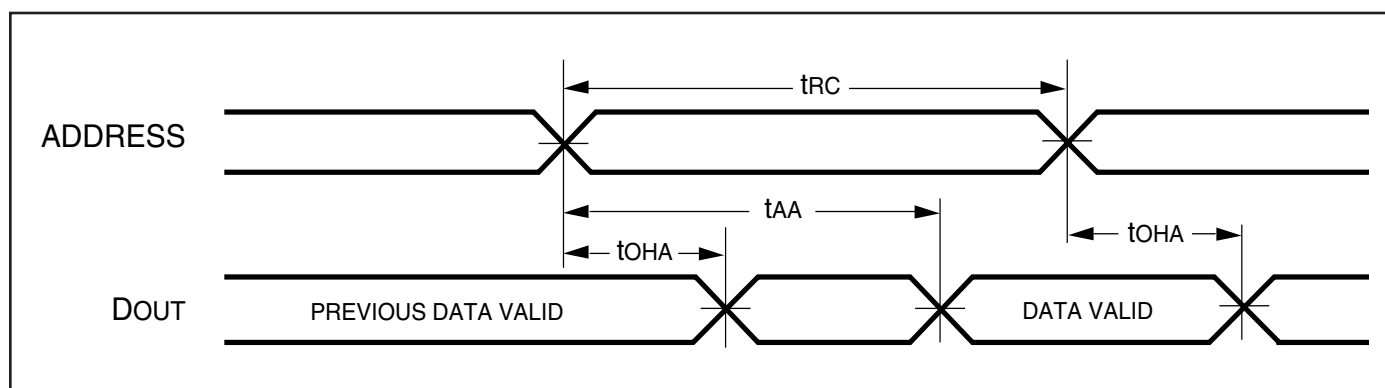

IS62WV2568ALL, IS62WV2568BLL

AC WAVEFORMS

READ CYCLE NO. 2^(1,3) ($\overline{CS1}$, $CS2$, \overline{OE} Controlled)

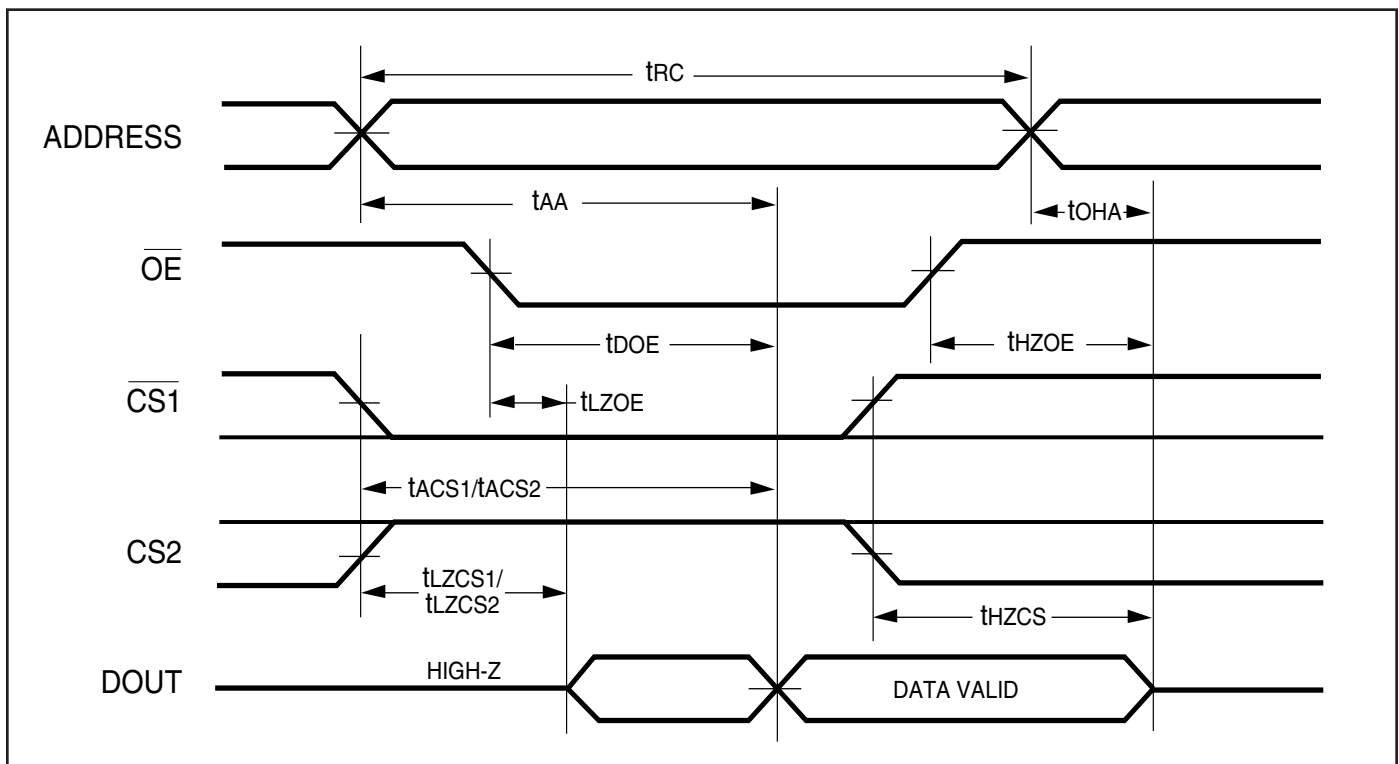

Notes:

1. \overline{WE} is HIGH for a Read Cycle.
2. The device is continuously selected. \overline{OE} , $\overline{CS1} = V_{IL}$. $CS2 = \overline{WE} = V_{IH}$.
3. Address is valid prior to or coincident with $\overline{CS1}$ LOW and $CS2$ HIGH transition.



IS62WV2568ALL, IS62WV2568BLL

WRITE CYCLE SWITCHING CHARACTERISTICS^(1,2) (Over Operating Range)

Symbol	Parameter	45ns		55ns		70ns		Unit
		Min.	Max.	Min.	Max.	Min.	Max.	
t _{WC}	Write Cycle Time	45	—	55	—	70	—	ns
t _{SCS1} /t _{SCS2}	$\overline{CS1}$ /CS2 to Write End	35	—	45	—	60	—	ns
t _{AW}	Address Setup Time to Write End	35	—	45	—	60	—	ns
t _{HA}	Address Hold from Write End	0	—	0	—	0	—	ns
t _{SA}	Address Setup Time	0	—	0	—	0	—	ns
t _{PWE}	\overline{WE} Pulse Width	35	—	40	—	50	—	ns
t _{SD}	Data Setup to Write End	20	—	25	—	30	—	ns
t _{HD}	Data Hold from Write End	0	—	0	—	0	—	ns
t _{HZWE}	\overline{WE} LOW to High-Z Output	—	20	—	20	—	20	ns
t _{LZWE}	\overline{WE} HIGH to Low-Z Output	5	—	5	—	5	—	ns

Notes:

1. Test conditions assume signal transition times of 5 ns or less, timing reference levels of 0.9V, input pulse levels of 0.4V to 1.4V and output loading specified in Figure 1.
2. The internal write time is defined by the overlap of $\overline{CS1}$ LOW, CS2 HIGH and \overline{WE} LOW. All signals must be in valid states to initiate a Write, but any one can go inactive to terminate the Write. The Data Input Setup and Hold timing are referenced to the rising or falling edge of the signal that terminates the write.
3. Tested with the load in Figure 2. Transition is measured ± 500 mV from steady-state voltage. Not 100% tested.

AC WAVEFORMS

WRITE CYCLE NO. 1 ($\overline{CS1}$ /CS2 Controlled, \overline{OE} = HIGH or LOW)

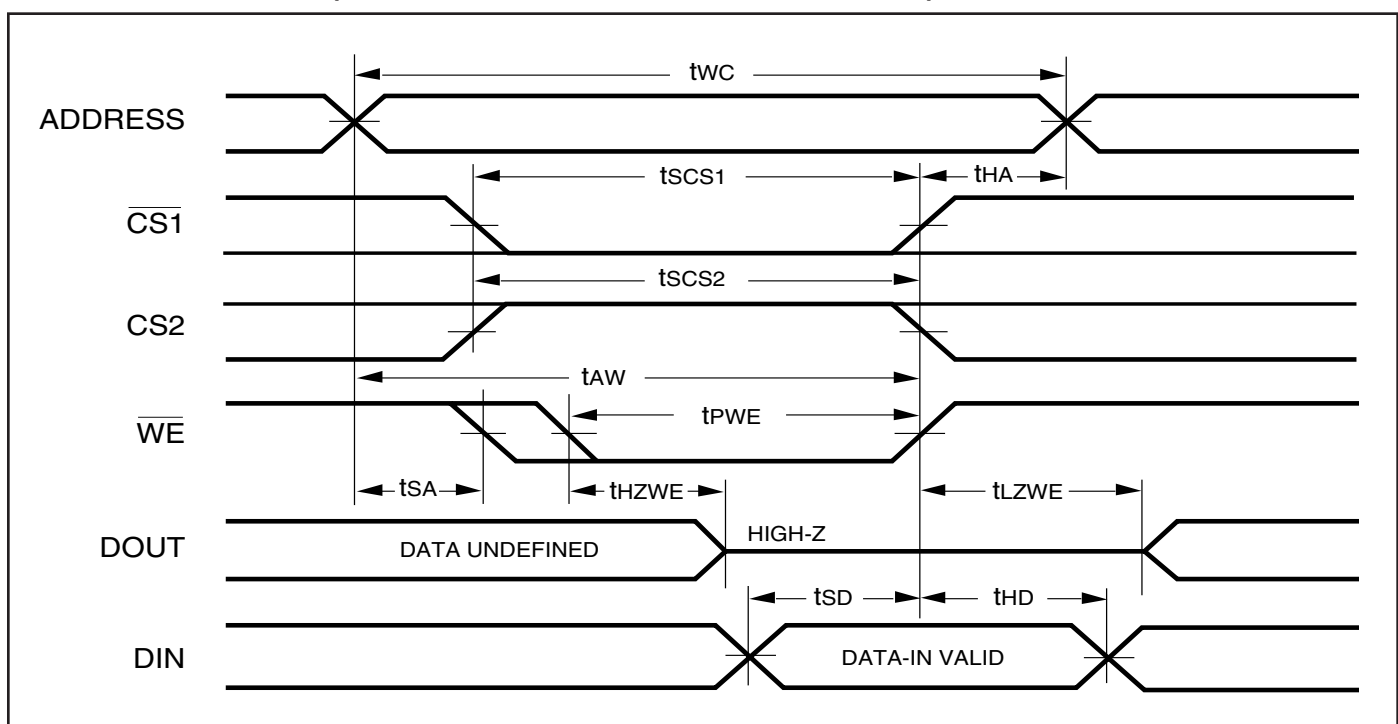

IS62WV2568ALL, IS62WV2568BLL

AC WAVEFORMS

WRITE CYCLE NO. 2 (\overline{WE} Controlled: \overline{OE} is HIGH During Write Cycle)

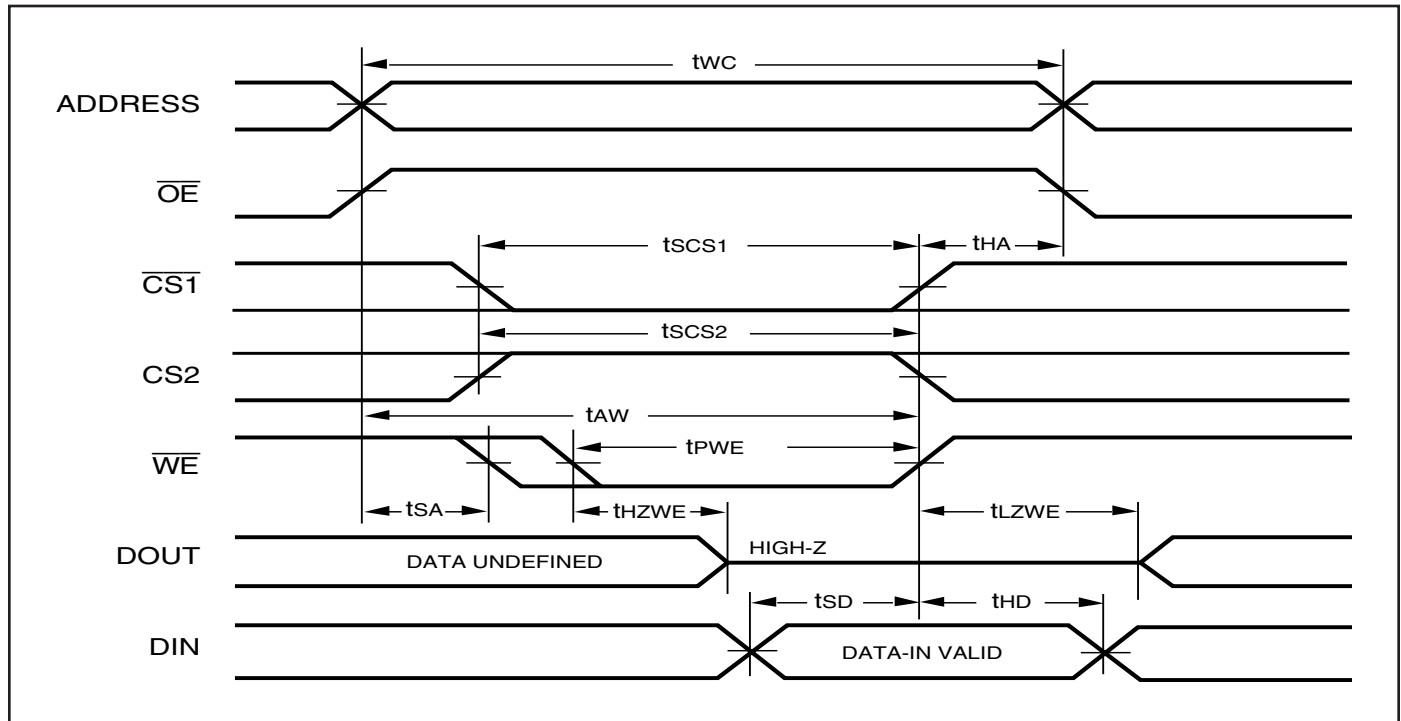

WRITE CYCLE NO. 3 (\overline{WE} Controlled: \overline{OE} is LOW During Write Cycle)

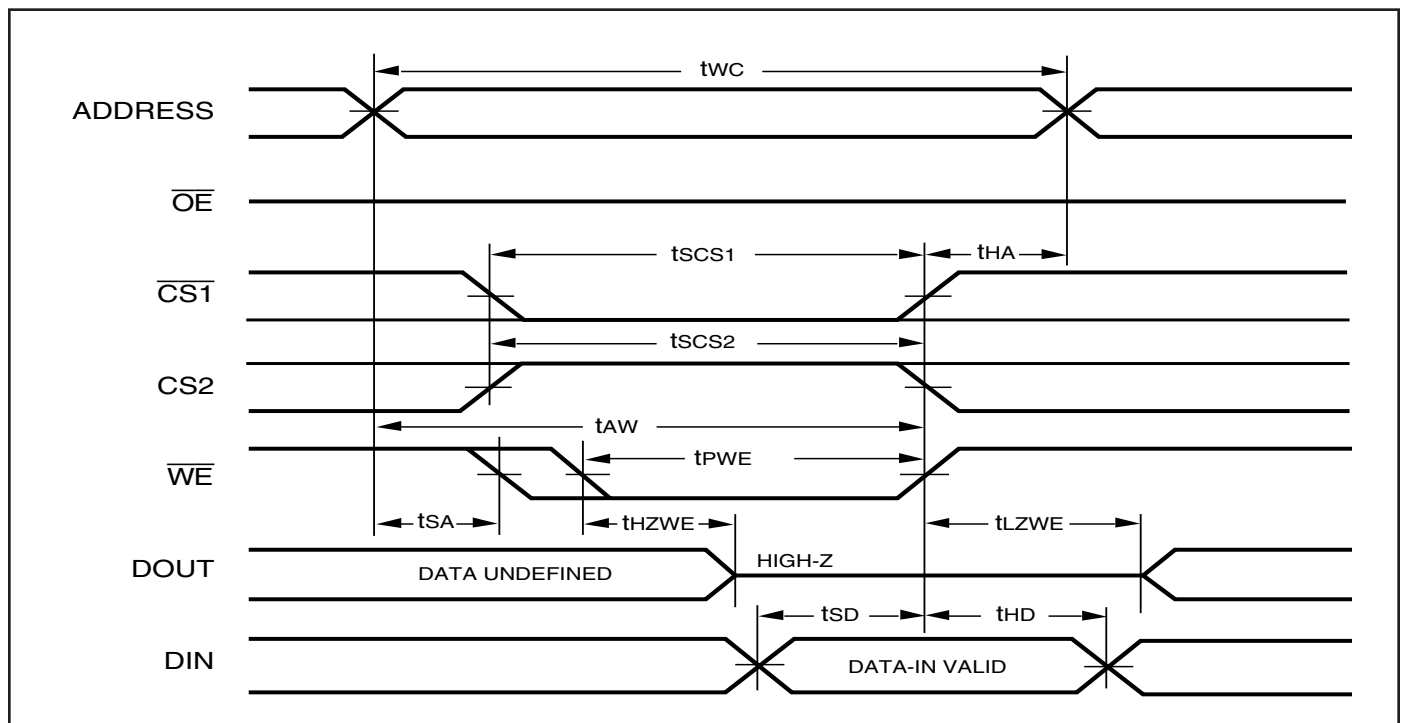



IS62WV2568ALL, IS62WV2568BLL

DATA RETENTION SWITCHING CHARACTERISTICS

Symbol	Parameter	Test Condition	Min.	Max.	Unit
V_{DR}	V_{CC} for Data Retention	See Data Retention Waveform	1.0	3.6	V
I_{DR}	Data Retention Current	$V_{CC} = 1.0V$, $\overline{CS1} \geq V_{CC} - 0.2V$	—	10	μA
t_{SDR}	Data Retention Setup Time	See Data Retention Waveform	0	—	ns
t_{RDR}	Recovery Time	See Data Retention Waveform	t_{RC}	—	ns

DATA RETENTION WAVEFORM ($\overline{CS1}$ Controlled)

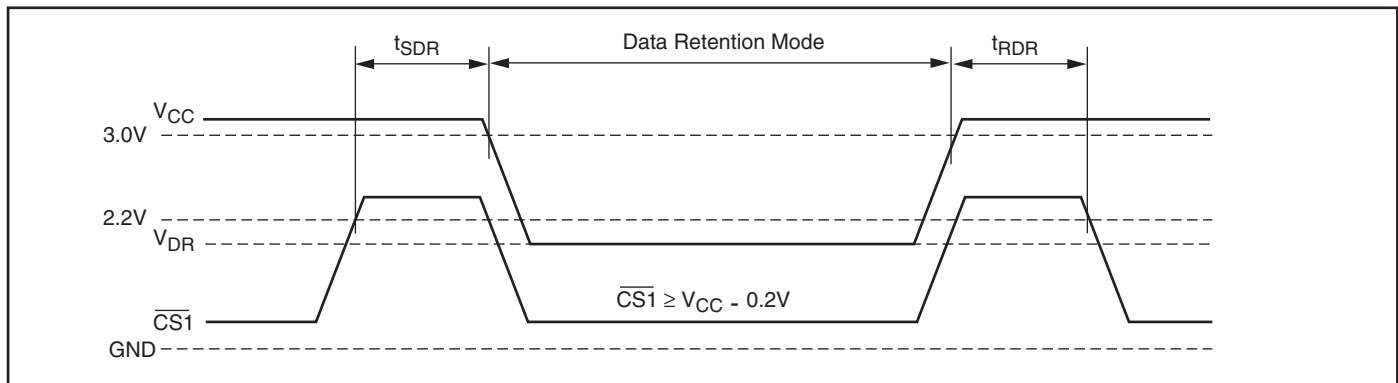

DATA RETENTION WAVEFORM ($CS2$ Controlled)

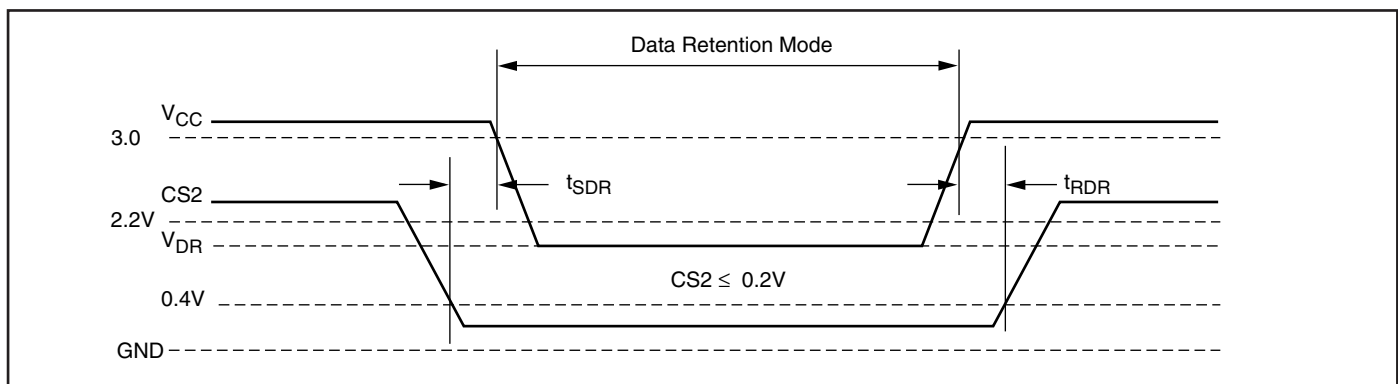



IS62WV2568ALL, IS62WV2568BLL

ORDERING INFORMATION

IS62WV2568ALL (1.65V - 2.2V)

Commercial Range: 0°C to +70°C

Speed (ns)	Order Part No.	Package
70	IS62WV2568ALL-70T	TSOP, TYPE I,

Industrial Range: -40°C to +85°C

Speed (ns)	Order Part No.	Package
70	IS62WV2568ALL-70TI	TSOP, TYPE I
70	IS62WV2568ALL-70TLI	TSOP, TYPE I, Lead-free
70	IS62WV2568ALL-70BI	mini BGA (6mm x 8mm)
70	IS62WV2568ALL-70BLI	mini BGA (6mm x 8mm), Lead-free
70	IS62WV2568ALL-70HI	sTSOP, TYPE I
70	IS62WV2568ALL-70HLI	sTSOP, TYPE I, Lead-free

IS62WV2568BLL (2.5V - 3.6V)

Commercial Range: 0°C to +70°C

Speed (ns)	Order Part No.	Package
70	IS62WV2568BLL-70T	TSOP, TYPE I
70	IS62WV2568BLL-70B	mini BGA (6mm x 8mm)
70	IS62WV2568BLL-70H	sTSOP, TYPE I

Industrial Range: -40°C to +85°C

Speed (ns)	Order Part No.	Package
45	IS62WV2568BLL-45TLI	TSOP, TYPE I, Lead-free
45	IS62WV2568BLL-45BLI	mini BGA (6mm x 8mm), Lead-free
45	IS62WV2568BLL-45HLI	sTSOP, TYPE I
55	IS62WV2568BLL-55TI	TSOP, TYPE I
55	IS62WV2568BLL-55TLI	TSOP, TYPE I, Lead-free
55	IS62WV2568BLL-55BI	mini BGA (6mm x 8mm)
55	IS62WV2568BLL-55BLI	mini BGA (6mm x 8mm), Lead-free
55	IS62WV2568BLL-55HI	sTSOP, TYPE I
55	IS62WV2568BLL-55HLI	sTSOP, TYPE I, Lead-free
70	IS62WV2568BLL-70TI	TSOP, TYPE I
70	IS62WV2568BLL-70BI	mini BGA (6mm x 8mm)
70	IS62WV2568BLL-70HI	sTSOP, TYPE I



IS62WV2568ALL, IS62WV2568BLL

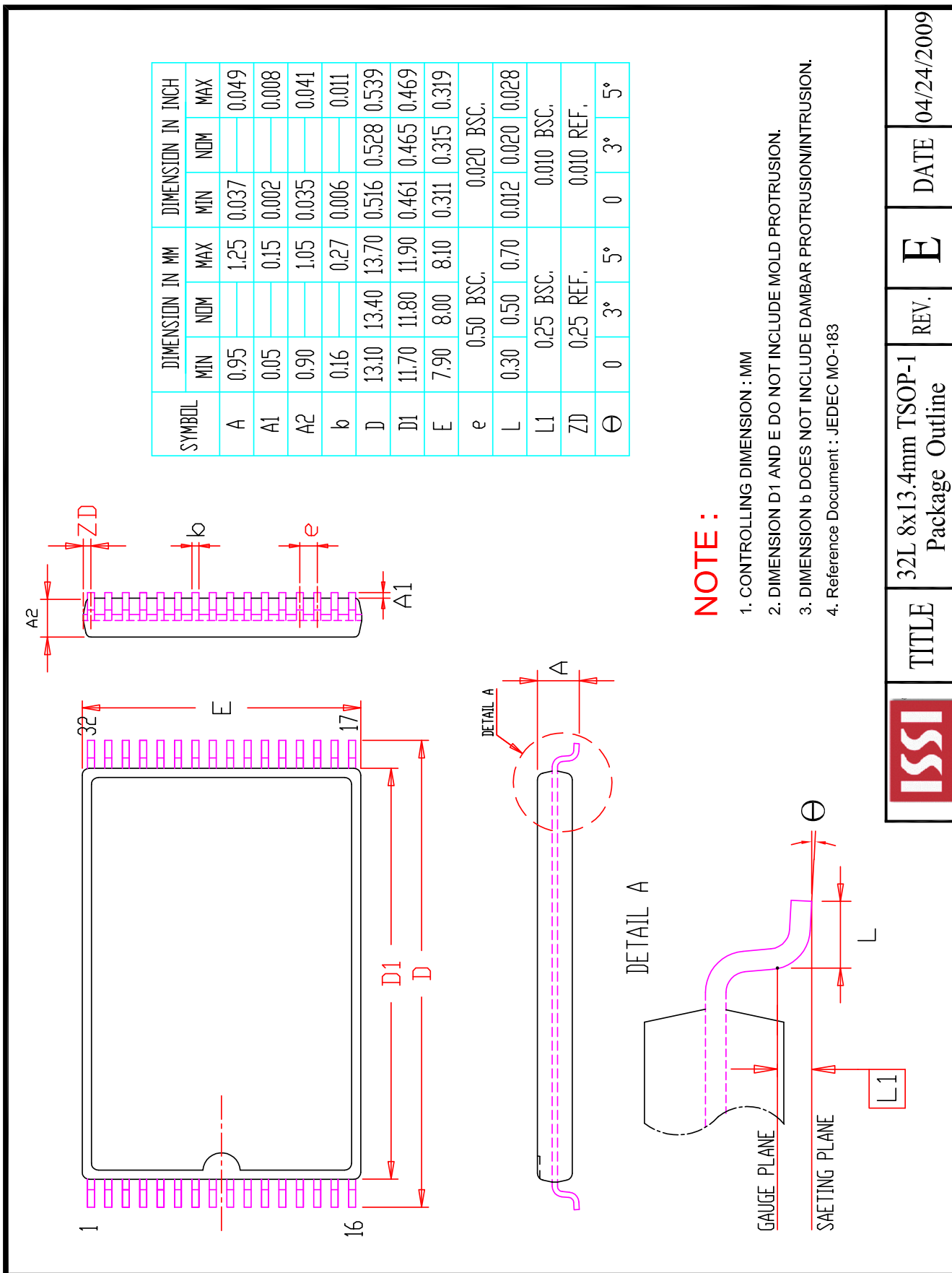

ISSI	TITLE	32L 8x13.4mm TSOP-1 Package Outline	REV.	E	DATE	04/24/2009
------	-------	-------------------------------------	------	---	------	------------

IS62WV2568ALL, IS62WV2568BLL

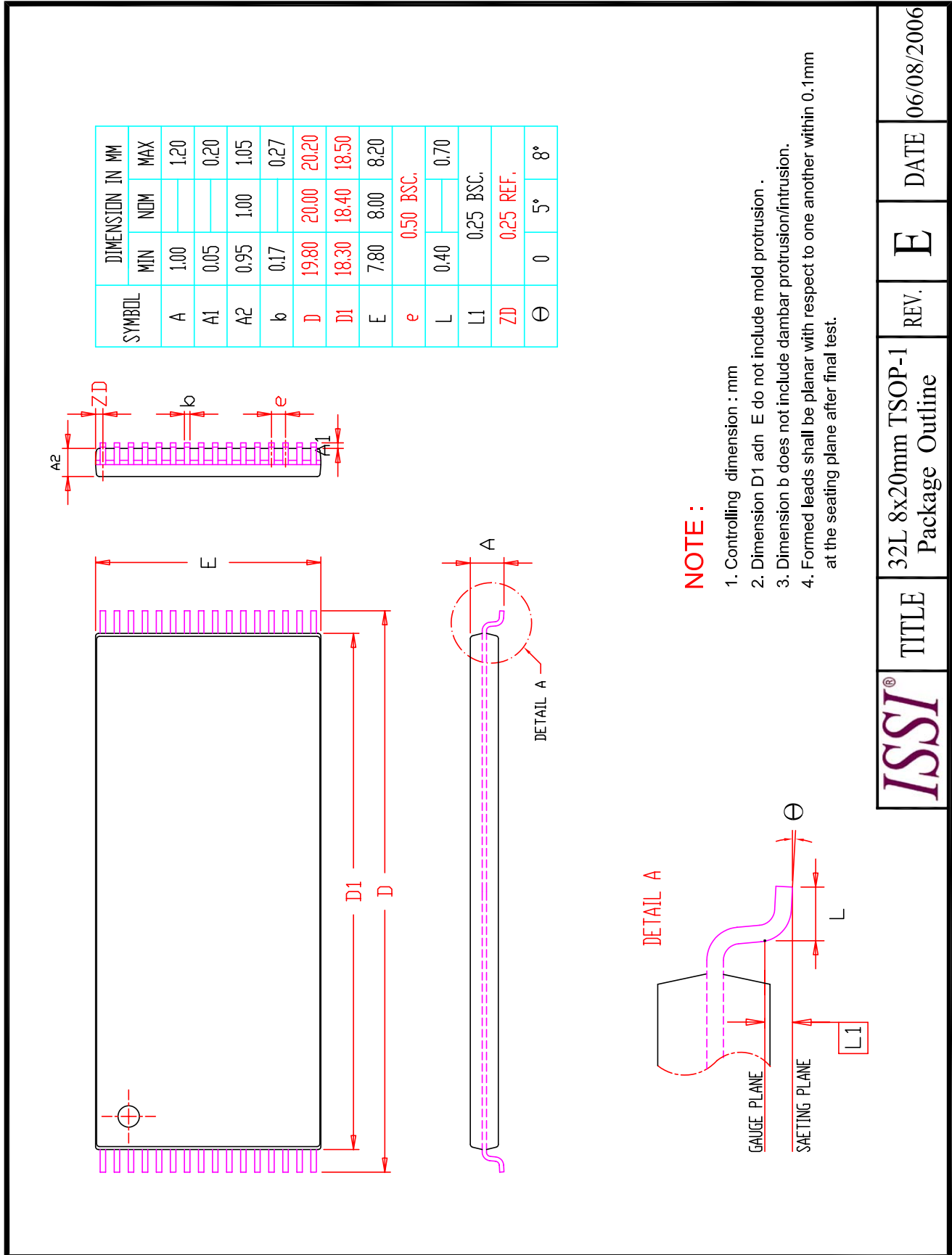

OUR CERTIFICATE

DiGi provide top-quality products and perfect service for customer worldwide through standardization, technological innovation and continuous improvement. DiGi through third-party certification, we stricly control the quality of products and services. Welcome your RFQ to

Email: Info@DiGi-Electronics.com



Tel: +00 852-30501935

RFQ Email: Info@DiGi-Electronics.com

DiGi is a global authorized distributor of electronic components.