

# HT06BN103FN Datasheet



<https://www.DiGi-Electronics.com>

DiGi Electronics Part Number	HT06BN103FN-DG
Manufacturer	<a href="#">KEMET</a>
Manufacturer Product Number	HT06BN103FN
Description	CAP CER 10000PF 50V COG/NPO RAD
Detailed Description	10000 pF ±1% 50V Ceramic Capacitor COG, NPO Radial

This model HT06BN103FN is available at DiGi Electronics.

DiGi Electronics offers a global database of semiconductor and electronic component datasheets.

We welcome your inquiries regarding pricing, lead time, or other product-related questions.

 [Request a Quote](#)

 [Datasheet Search](#)



Tel: +00 852-30501935

RFQ Email: [Info@DiGi-Electronics.com](mailto:Info@DiGi-Electronics.com)

DiGi is a global authorized distributor of electronic components.

## Purchase and inquiry

Manufacturer Product Number:

HT06BN103FN

Series:

HTHP LDD Indust COG HT200C

Capacitance:

10000 pF

Voltage - Rated:

50V

Operating Temperature:

-55°C ~ 200°C

Ratings:

-

Failure Rate:

-

Package / Case:

Radial

Height - Seated (Max):

0.300" (7.62mm)

Lead Spacing:

0.200" (5.08mm)

Manufacturer:

KEMET

Product Status:

Obsolete

Tolerance:

±1%

Temperature Coefficient:

COG, NPO

Features:

High Temperature

Applications:

General Purpose

Mounting Type:

Through Hole

Size / Dimension:

0.300" L x 0.150" W (7.62mm x 3.81mm)

Thickness (Max):

-

Lead Style:

Straight

## Environmental & Export classification

Moisture Sensitivity Level (MSL):

Not Applicable

HTSUS:

8532.24.0060

ECCN:

EAR99

# High Temperature (+200°C) Axial and Radial Ceramic Capacitors

## HT/HP Series

### FEATURES

The HT/HP Series is used in robust applications

- Down Hole
- Industrial
- Harsh Environments

Where a Radial/Axial coated capacitor can withstand high temperatures (200°C).

**NOTE:**

Other tolerances, higher capacitance values, voltages, or special package configurations are available upon request.

### CAPACITOR OUTLINE DRAWING

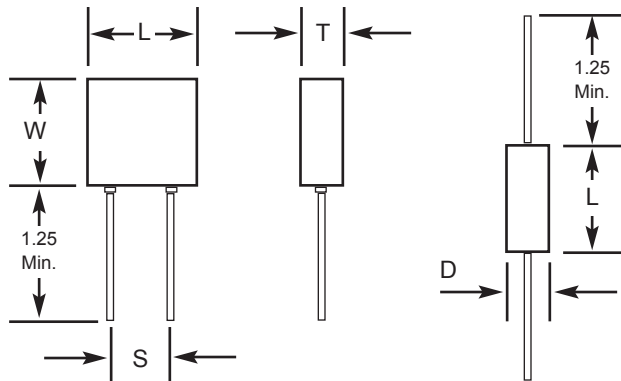

### DIMENSIONS

Molded (HT) and Conformal Coated (HP), Radial Lead Types

Style	Sizes in Inches (mm) max			Lead Spacing ±0.030 (S)
	Length (L)	Width (W)	Thickness (T)	
HT05	.200 (5.08)	.200 (5.08)	.100 (2.54)	.100 (2.54)
HT55	.200 (5.08)	.200 (5.08)	.100 (2.54)	.200 (5.08)
HT06	.300 (7.62)	.300 (7.62)	.150 (3.81)	.200 (5.08)
HT08	.500 (12.70)	.500 (12.70)	.250 (6.35)	.400 (10.16)
HT09	.700 (17.78)	.400 (10.16)	.200 (5.08)	.500 (12.70)

Tubular Case, Axial Lead Types

Style	Sizes in Inches (mm) max	
	Length (L)	Diameter (D)
HT11	.170 (4.32)	.100 (2.54)
HT13	.260 (6.60)	.135 (3.43)
HT14	.400 (10.16)	.155 (3.94)
HT15	.500 (12.70)	.200 (5.08)
HT16	.750 (19.05)	.375 (9.52)

### PART NUMBER AND ORDERING INFORMATION

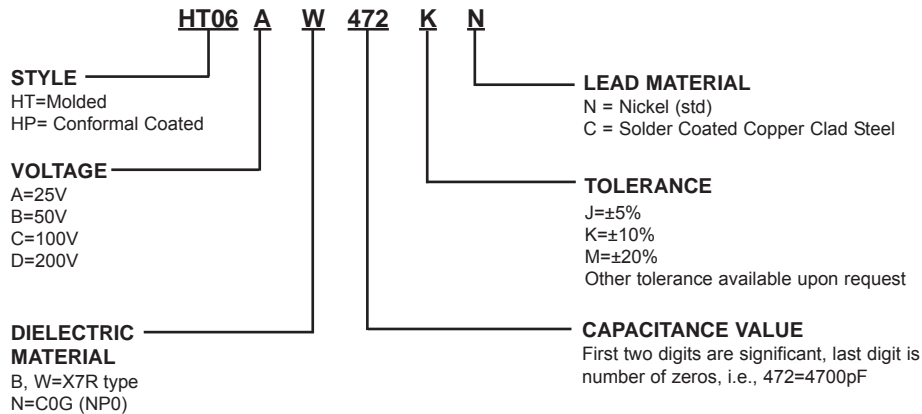

**MARKING**  
 (HT05, HT55, HT11)  
 472K  
 KEC  
  
 (All other sizes)  
 HT06AW472K  
 KEC  
 Date Code

For CONFORMAL COATED types, change style number to HPXX. HP dimensions will be reduced slightly.

### COG & X7R DIELECTRIC

COG RADIAL																		
STYLE		HT/HP 05			HT/HP 55			HT/HP 06			HT/HP 08			HT/HP 09				
Cap	Cap Code	50	100	200	50	100	200	50	100	200	50	100	200	50	100	200		
	22pF	220																
27	270																	
33	330																	
39	390																	
47	470																	
56	560																	
68	680																	
82	820																	
100	101																	
120	121																	
150	151																	
180	181																	
220	221																	
270	271																	
330	331																	
390	391																	
470	471																	
560	561																	
680	681																	
820	821																	
1000	102																	
1200	122																	
1500	152																	
1800	182																	
2200	222																	
2700	272																	
3300	332																	
3900	392																	
4700	472																	
5600	562																	
6800	682																	
8200	822																	
.010 uF	103																	
0.012	123																	
0.015	153																	
0.018	183																	
0.022	223																	
0.027	273																	
0.033	333																	
0.039	393																	
0.047	473																	
0.056	563																	
0.068	683																	
0.082	823																	
0.10	104																	
0.12	124																	

X7R RADIAL																		
STYLE		HT/HP 05			HT/HP 55			HT/HP 06			HT/HP 08			HT/HP 09				
Cap	Cap Code	50	100	200	50	100	200	50	100	200	50	100	200	50	100	200		
	1000pF	102																
1200	122																	
1500	152																	
1800	182																	
2200	222																	
2700	272																	
3300	332																	
3900	392																	
4700	472																	
5600	562																	
6800	682																	
8200	822																	
.010 uF	103																	
0.012	123																	
0.015	153																	
0.018	183																	
0.022	223																	
0.027	273																	
0.033	333																	
0.039	393																	
0.047	473																	
0.056	563																	
0.068	683																	
0.082	823																	
0.10	104																	
0.12	124																	
0.15	154																	
0.18	184																	
0.22	224																	
0.27	274																	
0.33	334																	
0.39	394																	
0.47	474																	
0.56	564																	
0.68	684																	
0.82	824																	
1.0	105																	
1.2	125																	
1.5	155																	
1.8	185																	
2.2	225																	
2.7	275																	
3.3	335																	
3.9	395																	
4.7	475																	
5.6	565																	

# High Temperature (+200 C) Axial and Radial Ceramic Capacitors HT/HP Series

## COG & X7R DIELECTRIC

COG AXIAL																
STYLE		HT/HP 11			HT/HP 13			HT/HP 14			HT/HP 15			HT/HP 16		
Cap	L MAX	.170 (4.32)	.260 (6.60)	.400 (10.16)	.500 (12.70)	.750 (19.05)										
	D MAX	.100 (2.54)	.135 (3.43)	.155 (3.94)	.200 (5.08)	.375 (9.52)										
	Lead Dia.	.025 (.635)	.025 (.635)	.025 (.635)	.025 (.635)	.025 (.635)										
Cap Code		WVDC			WVDC			WVDC			WVDC			WVDC		
		50	100	200	50	100	200	50	100	200	50	100	200	50	100	200
5.6pF	569															
6.8	689															
8.2	829															
10	100															
12	120															
15	150															
18	180															
22	220															
27	270															
33	330															
39	390															
47	470															
56	560															
68	680															
82	820															
100	101															
120	121															
150	151															
180	181															
220	221															
270	271															
330	331															
390	391															
470	471															
560	561															
680	681															
820	821															
1000	102															
1200	122															
1500	152															
1800	182															
2200	222															
2700	272															
3300	332															
3900	392															
4700	472															
5600	562															
6800	682															
8200	822															
.010 uF	103															
0.012	123															
0.015	153															
0.018	183															
0.022	223															
0.027	273															
0.033	333															
0.039	393															
0.047	473															
0.056	563															
0.068	683															
0.082	823															
0.10	104															

X7R AXIAL																
STYLE		HT/HP 11			HT/HP 13			HT/HP 14			HT/HP 15			HT/HP 16		
Cap	L MAX	.170 (4.32)	.260 (6.60)	.400 (10.16)	.500 (12.70)	.750 (19.05)										
	D MAX	.100 (2.54)	.135 (3.43)	.155 (3.94)	.200 (5.08)	.375 (9.52)										
	Lead Dia.	.025 (.635)	.025 (.635)	.025 (.635)	.025 (.635)	.025 (.635)										
Cap Code		WVDC			WVDC			WVDC			WVDC			WVDC		
		50	100	200	50	100	200	50	100	200	50	100	200	50	100	200
100pF	101															
120	121															
150	151															
180	181															
220	221															
270	271															
330	331															
390	391															
470	471															
560	561															
680	681															
820	821															
1000	102															
1200	122															
1500	152															
1800	182															
2200	222															
2700	272															
3300	332															
3900	392															
4700	472															
5600	562															
6800	682															
8200	822															
.010uF	103															
0.012	123															
0.015	153															
0.018	183															
0.022	223															
0.027	273															
0.033	333															
0.039	393															
0.047	473															
0.056	563															
0.068	683															
0.082	823															
0.1	104															
0.12	124															
0.15	154															
0.18	184															
0.22	224															
0.27	274															
0.33	334															
0.39	394															
0.47	474															
0.56	564															
0.68	684															
0.82	824															
1.0	105															
1.2	125															
1.5	155															
1.8	185															
2.2	225															
2.7	275															

## OUR CERTIFICATE

DiGi provide top-quality products and perfect service for customer worldwide through standardization, technological innovation and continuous improvement. DiGi through third-party certification, we stricly control the quality of products and services. Welcome your RFQ to

Email: [Info@DiGi-Electronics.com](mailto:Info@DiGi-Electronics.com)



Tel: +00 852-30501935

RFQ Email: [Info@DiGi-Electronics.com](mailto:Info@DiGi-Electronics.com)

DiGi is a global authorized distributor of electronic components.