

# LTC7545ALG#TRPBF Datasheet

www.digi-electronics.com

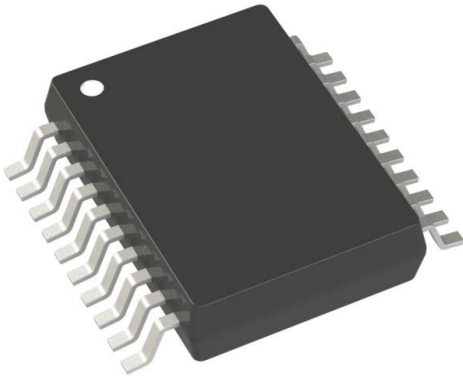

<https://www.DiGi-Electronics.com>

DiGi Electronics Part Number	LTC7545ALG#TRPBF-DG
Manufacturer	<a href="#">Analog Devices Inc.</a>
Manufacturer Product Number	LTC7545ALG#TRPBF
Description	IC DAC 12BIT A-OUT 20SSOP
Detailed Description	12 Bit Digital to Analog Converter 1 20-SSOP

This model LTC7545ALG#TRPBF is available at DiGi Electronics.

DiGi Electronics offers a global database of semiconductor and electronic component datasheets.

We welcome your inquiries regarding pricing, lead time, or other product-related questions.

 [Request a Quote](#)

 [Datasheet Search](#)



Tel: +00 852-30501935

RFQ Email: [Info@DiGi-Electronics.com](mailto:Info@DiGi-Electronics.com)

DiGi is a global authorized distributor of electronic components.

## Purchase and inquiry

Manufacturer Product Number:

LTC7545ALG#TRPBF

Series:

-

DiGi-Electronics Programmable:

Not Verified

Number of D/A Converters:

1

Output Type:

Current - Unbuffered

Data Interface:

Parallel

Voltage - Supply, Analog:

5V, 14.25V ~ 15.75V

INL/DNL (LSB):

±0.5 (Max), ±0.5 (Max)

Operating Temperature:

0°C ~ 70°C

Supplier Device Package:

20-SSOP

Base Product Number:

LTC7545

Manufacturer:

Analog Devices Inc.

Product Status:

Active

Number of Bits:

12

Settling Time:

1µs

Differential Output:

No

Reference Type:

External

Voltage - Supply, Digital:

5V, 14.25V ~ 15.75V

Architecture:

R-2R

Package / Case:

20-SSOP (0.209", 5.30mm Width)

Mounting Type:

Surface Mount

## Environmental & Export classification

RoHS Status:

ROHS3 Compliant

REACH Status:

REACH Unaffected

HTSUS:

8542.39.0001

Moisture Sensitivity Level (MSL):

1 (Unlimited)

ECCN:

EAR99

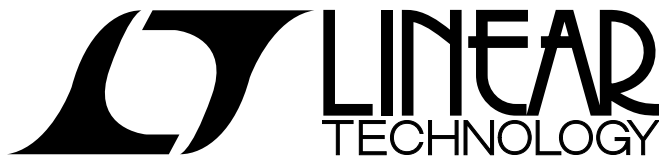

LTC7545A

## Improved Industry Standard Parallel 12-Bit Multiplying DAC

### FEATURES

- Improved Direct Replacement for AD7545A and AD7545
- DNL and INL Over Temperature:  $\pm 0.5\text{LSB}$
- Gain Error:  $\pm 1\text{LSB}$  Maximum
- 4-Quadrant Multiplication
- Single 5V or 15V Supply
- Low Power Consumption
- Low Cost

### APPLICATIONS

- Process Control and Industrial Automation
- Software Controlled Gain Adjustment
- Digitally Controlled Filter and Power Supplies
- Automatic Test Equipment

### DESCRIPTION

The LTC<sup>®</sup>7545A is a 12-bit multiplying digital-to-analog converter (DAC) with a microprocessor compatible parallel input. It is a superior pin compatible replacement for the industry standard AD7545A and AD7545. Improvements include better accuracy, better stability over temperature and supply variations and lower sensitivity to output amplifier offset.

This very versatile DAC is useful for 2-quadrant and 4-quadrant multiplying, programmable gain and filtering and single supply noninverting voltage output operation.

Parts are available in 20-pin PDIP and SO packages and commercial and industrial temperature grades.

LTC and LT are registered trademarks of Linear Technology Corporation.

### TYPICAL APPLICATION

2-Quadrant Multiplying DAC Has Less Than  
0.5LSB (Typ) Total Unadjusted Error

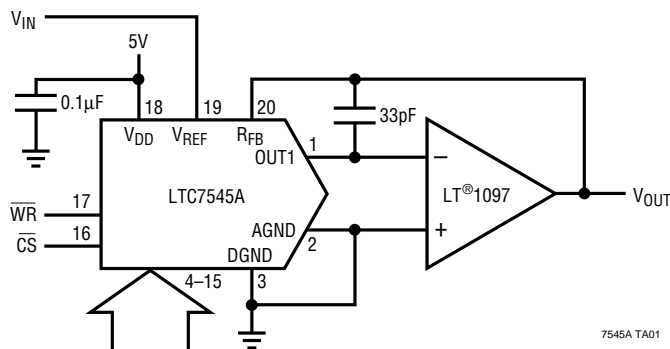

Integral Nonlinearity Over Temperature

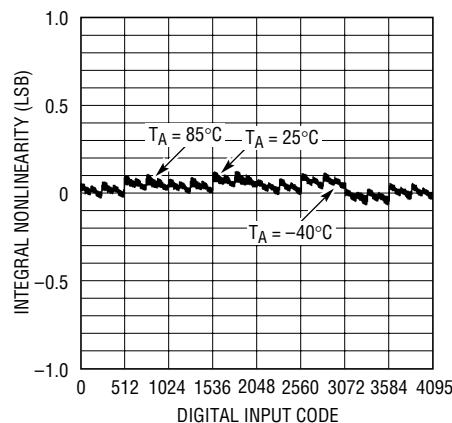

7545A TA02

## LTC7545A

## ABSOLUTE MAXIMUM RATINGS

$V_{DD}$ to AGND	-0.5V to 17V
$V_{DD}$ to DGND	-0.5V to 17V
AGND to DGND	-0.5V to $V_{DD} + 0.5V$
DGND to AGND	-0.5V to $V_{DD} + 0.5V$
$V_{REF}$ to AGND, DGND	$\pm 25V$
$R_{FB}$ to AGND, DGND	$\pm 25V$
Digital Inputs to DGND	-0.5V to $V_{DD} + 0.5V$
$V_{OUT1}$ to AGND, DGND	-0.5V to $V_{DD} + 0.5V$
Maximum Junction Temperature	150°C
Operating Temperature Range	
Commercial (K, L Versions)	0°C to 70°C
Industrial (B, C Versions)	-40°C to 85°C
Storage Temperature Range	-65°C to 150°C
Lead Temperature (Soldering, 10 sec)	300°C

## PACKAGE/ORDER INFORMATION

TOP VIEW		ORDER PART NUMBER
OUT1 [1]	[20] $R_{FB}$	LTC7545ABG
AGND [2]	[19] $V_{REF}$	LTC7545ABN
DGND [3]	[18] $V_{DD}$	LTC7545ABSW
DB11 (MSB) [4]	[17] $WR$	LTC7545ACG
DB10 [5]	[16] $CS$	LTC7545ACN
DB9 [6]	[15] DB0 (LSB)	LTC7545ACSW
DB8 [7]	[14] DB1	LTC7545AKG
DB7 [8]	[13] DB2	LTC7545AKN
DB6 [9]	[12] DB3	LTC7545AKSW
DB5 [10]	[11] DB4	LTC7545ALG
		LTC7545ALN
		LTC7545ALSW

G PACKAGE                      N PACKAGE  
 20-LEAD PLASTIC SSOP        20-LEAD PDIP  
 SW PACKAGE  
 20-LEAD PLASTIC SO WIDE

$T_{JMAX} = XXX^{\circ}C, \theta_{JA} = XXX^{\circ}C/W$  (G)  
 $T_{JMAX} = 150^{\circ}C, \theta_{JA} = 100^{\circ}C/W$  (N)  
 $T_{JMAX} = 150^{\circ}C, \theta_{JA} = 130^{\circ}C/W$  (SW)

Consult factory for Military grade parts.

## ELECTRICAL CHARACTERISTICS

 $V_{DD} = 5V$  or  $15V$ ,  $V_{REF} = 10V$ ,  $V_{OUT1} = AGND = 0V$ ,  $T_A = T_{MIN}$  to  $T_{MAX}$ , unless otherwise noted.

SYMBOL	PARAMETER	CONDITIONS	LTC7545AK/AB			LTC7545AL/AC			UNITS	
			MIN	TYP	MAX	MIN	TYP	MAX		
<b>Accuracy</b>										
	Resolution		●	12		12			Bits	
INL	Integral Nonlinearity (Relative Accuracy)	(Note 1) $T_A = 25^{\circ}C$ $T_{MIN}$ to $T_{MAX}$	●		$\pm 0.5$ $\pm 0.5$		$\pm 0.5$ $\pm 0.5$		LSB LSB	
DNL	Differential Nonlinearity	Guaranteed Monotonic $T_{MIN}$ to $T_{MAX}$ $T_A = 25^{\circ}C$ $T_{MIN}$ to $T_{MAX}$	●		$\pm 1$ $\pm 1$		$\pm 0.5$ $\pm 0.5$		LSB LSB	
GE	Gain Error	(Note 2) $T_A = 25^{\circ}C$ $T_{MIN}$ to $T_{MAX}$	●		$\pm 2$ $\pm 3$		$\pm 1$ $\pm 2$		LSB LSB	
	Gain Temperature Coefficient	(Note 3) $\Delta Gain/\Delta Temperature$	●	1	5		1	5	ppm/ $^{\circ}C$	
$I_{LKG}$	OUT1 Leakage Current	(Note 4) $T_A = 25^{\circ}C$ $T_{MIN}$ to $T_{MAX}$	●		$\pm 10$ $\pm 50$		$\pm 10$ $\pm 50$		nA nA	
PSRR	Power Supply Rejection		●		$\pm 0.002$		$\pm 0.002$		%/%	
<b>Reference Input</b>										
$R_{REF}$	$V_{REF}$ Input Resistance	(Note 5)	●	8	11	15	8	11	15	k $\Omega$
<b>AC Performance</b>										
	Output Current Settling Time	(Notes 3, 6, 7)	●		1		1		$\mu s$	
	Propagation Delay	(Notes 3, 6, 8)	●		150		150		ns	
	Digital-to-Analog Glitch Impulse	(Notes 6, 9)	●		5		5		nV-sec	
	Multiplying Feedthrough Error	$V_{REF} = \pm 10V$ , 10kHz Sine Wave	●		5		5		mV <sub>p-p</sub>	
<b>Analog Outputs</b>										
$C_{OUT}$	Output Capacitance (Note 3)	DB0 to DB11 = 0V, $WR, CS = 0V$	●	30	70		30	70	pF	
		DB0 to DB11 = $V_{DD}$ , $WR, CS = 0V$	●	60	150		60	150	pF	

**ELECTRICAL CHARACTERISTICS** $V_{DD} = 5V$ ,  $V_{REF} = 10V$ ,  $V_{OUT1} = AGND = 0V$ ,  $T_A = T_{MIN}$  to  $T_{MAX}$ , unless otherwise noted.

SYMBOL	PARAMETER	CONDITIONS	ALL GRADES			UNITS	
			MIN	TYP	MAX		
<b>Digital Inputs</b>							
$V_{IH}$	Digital Input High Voltage		●	2.4		V	
$V_{IL}$	Digital Input Low Voltage		●		0.8	V	
$I_{IN}$	Digital Input Current		●	0.001	±1	μA	
$C_{IN}$	Digital Input Capacitance	(Note 3) $V_{IN} = 0V$	●		8	pF	
<b>Timing Characteristics (Note 3)</b>							
$t_{CS}$	$\overline{CS}$ to $\overline{WR}$ Setup Time		●	100		ns	
$t_{CH}$	$\overline{CS}$ to $\overline{WR}$ Hold Time		●	0		ns	
$t_{WR}$	Write Pulse Width		●	100		ns	
$t_{DS}$	Data Setup Time		●	100		ns	
$t_{DH}$	Data Hold Time		●	5		ns	
<b>Power Supply</b>							
$V_{DD}$	Supply Voltage		●	4.75	5	5.25	V
$I_{DD}$	Supply Current	All Digital Inputs = $V_{IH}$ or $V_{IL}$	●			2	mA
		All Digital Inputs = 0V or $V_{DD}$	●		10	100	μA

 $V_{DD} = 15V$ ,  $V_{REF} = 10V$ ,  $V_{OUT1} = AGND = 0V$ ,  $T_A = T_{MIN}$  to  $T_{MAX}$ , unless otherwise noted.

SYMBOL	PARAMETER	CONDITIONS	ALL GRADES			UNITS	
			MIN	TYP	MAX		
<b>Digital Inputs</b>							
$V_{IH}$	Digital Input High Voltage		●	13.5		V	
$V_{IL}$	Digital Input Low Voltage		●		1.5	V	
$I_{IN}$	Digital Input Current		●		±1	μA	
$C_{IN}$	Digital Input Capacitance	(Note 3) $V_{IN} = 0V$	●		8	pF	
<b>Timing Characteristics (Note 3)</b>							
$t_{CS}$	$\overline{CS}$ to $\overline{WR}$ Setup Time		●	75		ns	
$t_{CH}$	$\overline{CS}$ to $\overline{WR}$ Hold Time		●	0		ns	
$t_{WR}$	Write Pulse Width		●	75		ns	
$t_{DS}$	Data Setup Time		●	60		ns	
$t_{DH}$	Data Hold Time		●	5		ns	
<b>Power Supply</b>							
$V_{DD}$	Supply Voltage		●	14.25	15	15.75	V
$I_{DD}$	Supply Current	All Digital Inputs = $V_{IH}$ or $V_{IL}$	●			2	mA
		All Digital Inputs = 0V or $V_{DD}$	●		10	100	μA

The ● denotes specifications which apply over the full operating temperature range.

**Note 1:**  $\pm 0.5LSB = \pm 0.012\%$  of full scale.

**Note 2:** Using internal feedback resistor.

**Note 3:** Guaranteed by design, not subject to test.

**Note 4:**  $I_{OUT1}$  with DAC register loaded to all 0s.

**Note 5:** Typical temperature coefficient is 100ppm/°C.

**Note 6:**  $OUT1$  load = 100Ω in parallel with 13pF.

**Note 7:** To 0.01% for a full-scale change, measured from the falling edge of  $WR$ ,  $CS = 0V$ .

**Note 8:** From digital input change to 90% of final analog output.

**Note 9:**  $V_{REF} = 0V$ . DAC register contents changed from all 0s to all 1s or all 1s to all 0s.

# LTC7545A

## BLOCK DIAGRAM

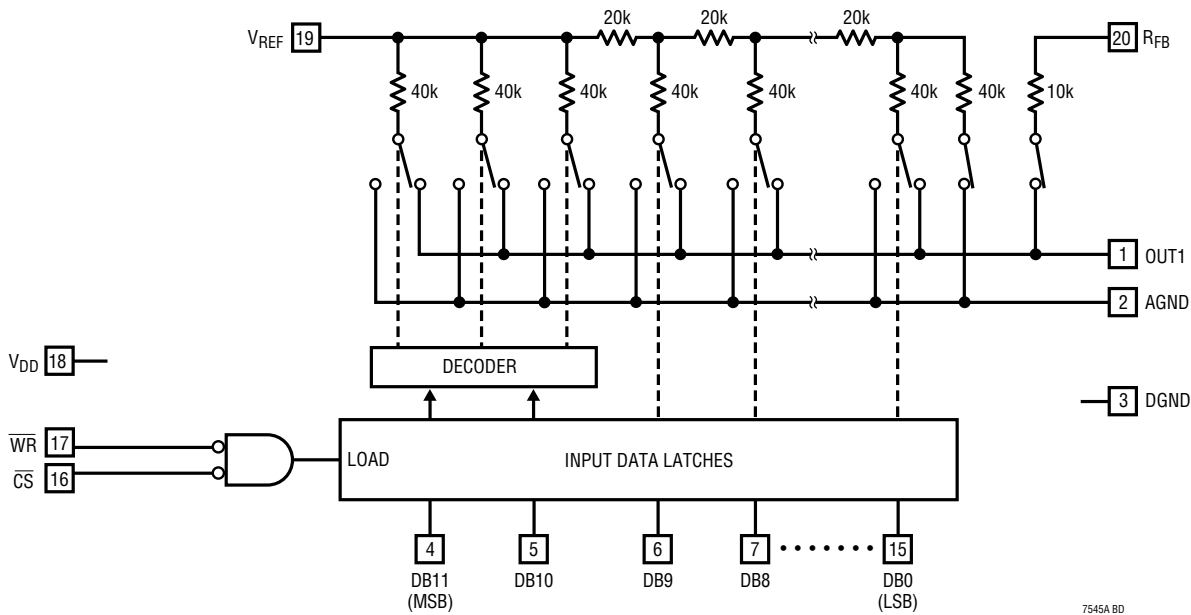

## TIMING DIAGRAM

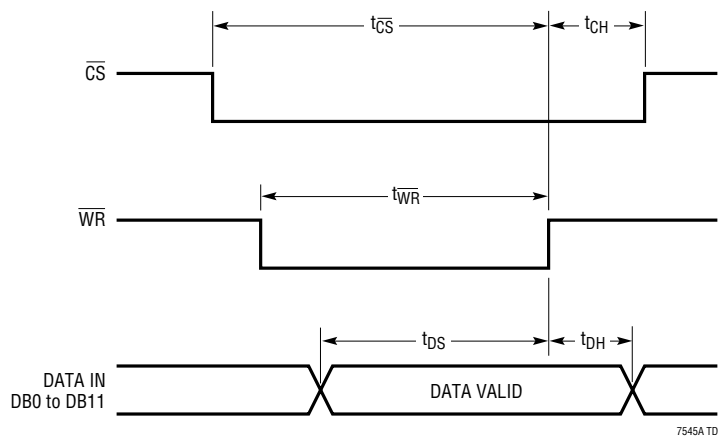

## TYPICAL APPLICATIONS

### Unipolar Operation (2-Quadrant Multiplication)

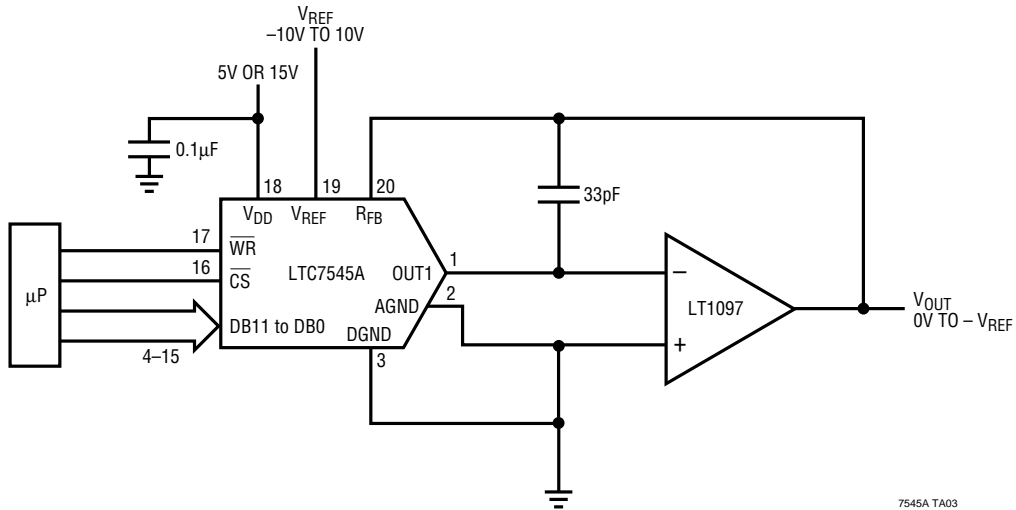

Table 1. Unipolar Binary Code Table

DIGITAL INPUT BINARY NUMBER IN DAC LATCH			ANALOG OUTPUT $V_{OUT}$
MSB		LSB	
1111	1111	1111	$-V_{REF}$ (4095/4096)
1000	0000	0000	$-V_{REF}$ (2048/4096) = $-V_{REF}/2$
0000	0000	0001	$-V_{REF}$ (1/4096)
0000	0000	0000	0V

## LTC7545A

## TYPICAL APPLICATIONS

## Bipolar Operation (4-Quadrant Multiplication)

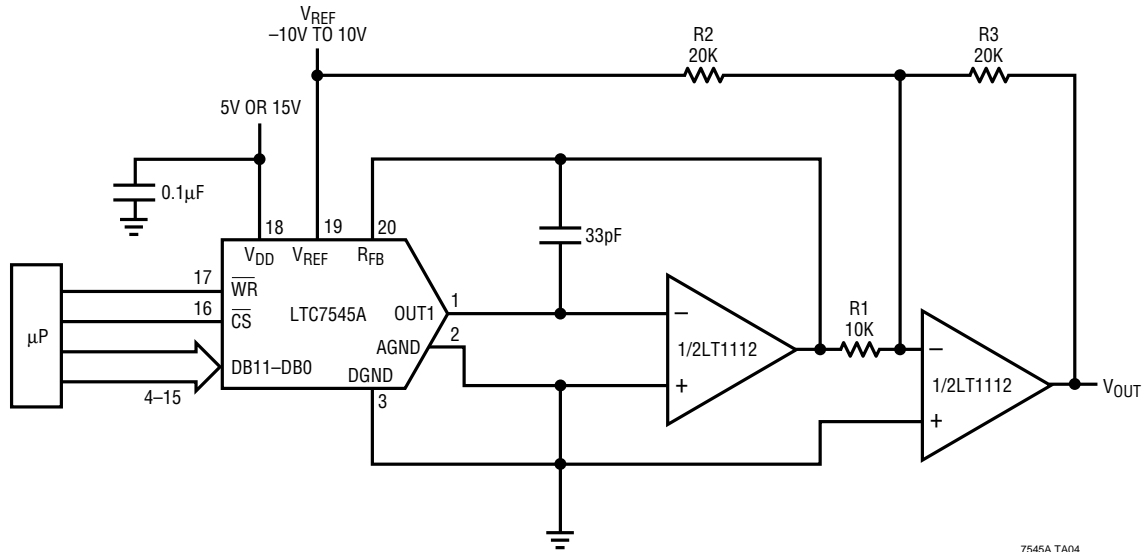

7545A TA04

Table 2. Bipolar Offset Binary Code Table

DIGITAL INPUT BINARY NUMBER IN DAC LATCH			ANALOG OUTPUT $V_{OUT}$
MSB		LSB	
1111	1111	1111	$V_{REF}$ (2047/2048)
1000	0000	0001	$V_{REF}$ (1/2048)
1000	0000	0000	0V
0111	1111	1111	$-V_{REF}$ (1/2048)
0000	0000	0000	$-V_{REF}$ (2048/2048) = $-V_{REF}$





## OUR CERTIFICATE

DiGi provide top-quality products and perfect service for customer worldwide through standardization, technological innovation and continuous improvement. DiGi through third-party certification, we stricly control the quality of products and services. Welcome your RFQ to

Email: [Info@DiGi-Electronics.com](mailto:Info@DiGi-Electronics.com)



Tel: +00 852-30501935

RFQ Email: [Info@DiGi-Electronics.com](mailto:Info@DiGi-Electronics.com)

DiGi is a global authorized distributor of electronic components.