

KSC351GLFS Datasheet

www.digi-electronics.com



<https://www.DiGi-Electronics.com>

DiGi Electronics Part Number	KSC351GLFS-DG
Manufacturer	C&K
Manufacturer Product Number	KSC351GLFS
Description	SWITCH TACTILE SPST-NO 0.05A 32V
Detailed Description	Tactile Switch SPST-NO Top Actuated Surface Mount

This model KSC351GLFS is available at DiGi Electronics.

DiGi Electronics offers a global database of semiconductor and electronic component datasheets.

We welcome your inquiries regarding pricing, lead time, or other product-related questions.

 [Request a Quote](#)

 [Datasheet Search](#)



Tel: +00 852-30501935

RFQ Email: Info@DiGi-Electronics.com

DiGi is a global authorized distributor of electronic components.

Purchase and inquiry

Manufacturer Product Number:

KSC351GLFS

Series:

KSC

Circuit:

SPST-NO

Contact Rating @ Voltage:

0.05A @ 32VDC

Mounting Type:

Surface Mount

Actuator Length, Right Angle:

-

Termination Style:

Gull Wing

Illumination:

Non-Illuminated

Illumination Voltage (Nominal):

-

Ingress Protection:

IP67 - Dust Tight, Waterproof

Operating Temperature:

-40°C ~ 85°C

Switch Travel:

0.25mm

Base Product Number:

KSC351

Manufacturer:

C&K

Product Status:

Active

Switch Function:

Off-Mom

Actuator Type:

Standard

Actuator Height off PCB, Vertical:

3.50mm

Actuator Orientation:

Top Actuated

Outline:

6.20mm x 6.20mm

Illumination Type, Color:

-

Operating Force:

500gf

Features:

-

Actuator Material:

-

Mechanical Life:

100,000 Cycles

Environmental & Export classification

RoHS Status:

ROHS3 Compliant

REACH Status:

REACH Unaffected

HTSUS:

8536.50.9031

Moisture Sensitivity Level (MSL):

1 (Unlimited)

ECCN:

EAR99

KSC3 Series

Sealed Tactile Switch for SMT 6.2 x 6.2 mm,
with 3.5 mm Height Hard Actuator



Specifications

Function	Momentary action
Contact Arrangement	1 make contact = SPST, N.O.
Terminals	J bend & Gullwing type for SMT
Sealing	IP67
Packaging	Switches delivered on continuous tape & reels of 2,000 pieces Dimensions according to EIA RS-481/ IEC 60286-3 standard External diameter 330 ± 2 mm

Description

The KSC3 series sealed tactile switches for SMT are designed for small applications and products. Their positive adaptable tactile feeling is perfect for industrial, automotive and consumer applications, such as mobile phones and car door handles. KSC3 switches are IP67 rated, 3.5mm high hard actuator tactile switches.

Features & Benefits

- Positive adaptable tactile feeling
- Hard actuator 3.5mm high
- IP67

Applications

- Industrial electronics
- Consumer products
- Transportation
- Medical

Dimensions (mm) J Termination

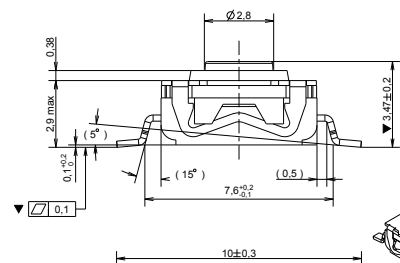

Dimensions (mm) G Termination

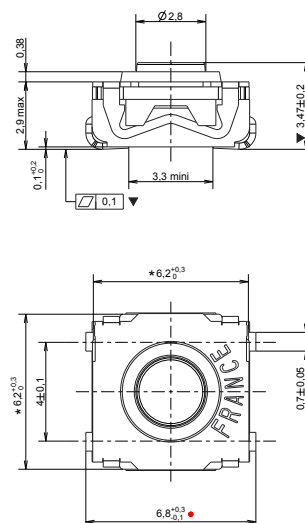

KSC3 Series

Sealed Tactile Switch for SMT 6.2 x 6.2 mm,
with 3.5 mm Height Hard Actuator



Mechanical Characteristics

Part #	Operating Force FA (Newtons)	Operating Life (operations)	Travel (mm)
KSC321	2 ± 0.4	300,000	0.2 + 0.3/- 0
KSC341	3 ± 0.75	300,000	0.2 + 0.3/- 0
KSC351	5 ± 1	100,000	0.25 + 0.3/- 0

Soldering Profile

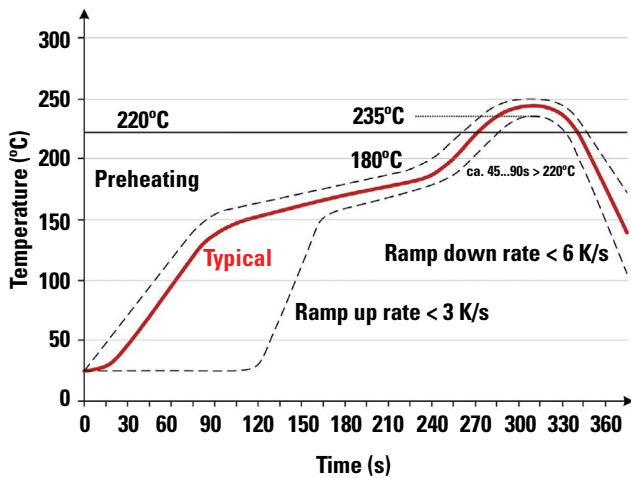

Note: Up to 2 reflow cycles in accordance with the above temperature profile

Soldering process: Depending on the application, this component is suited to the following methods:

- Terminals being silver or gold plated over a nickel barrier, the use of slightly activated flux is suitable.
- Lead free soldering process in accordance with the definition on the left.

J Terminations (mm)

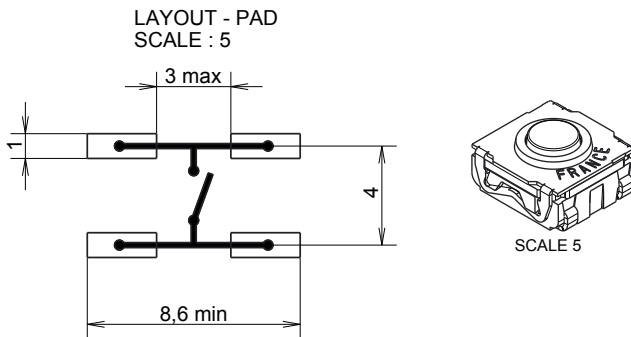

G Terminations (mm)

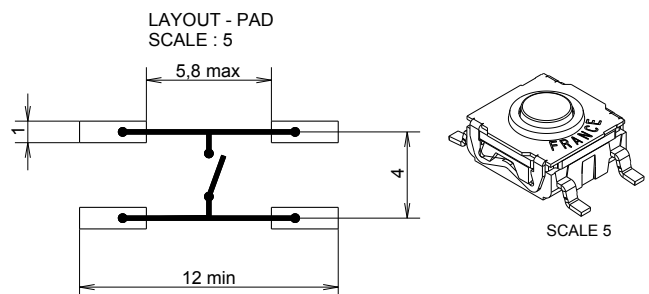

KSC3 Series

Sealed Tactile Switch for SMT 6.2 x 6.2 mm,
with 3.5 mm Height Hard Actuator



Tape & Reel

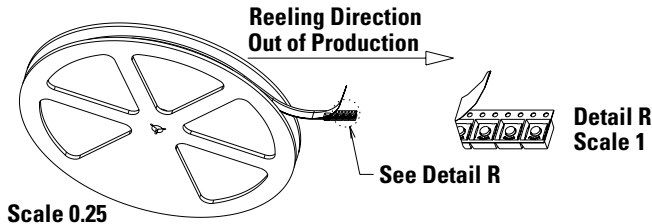

Packaging Details

Type	Tape & reel
Number of Parts in Packaging	2,000
Other Information	Tape and reel per EIA 481
Transport Conditions	According to specification NF H00-060

Ordering Number

Our easy build-a-switch concept allows you to mix and match options to create the switch you need. To order, select desired option from each category and place it in the appropriate box. However, please note that all the combinations of these options are not feasible. For any part number different from those listed above, please consult your local representative.

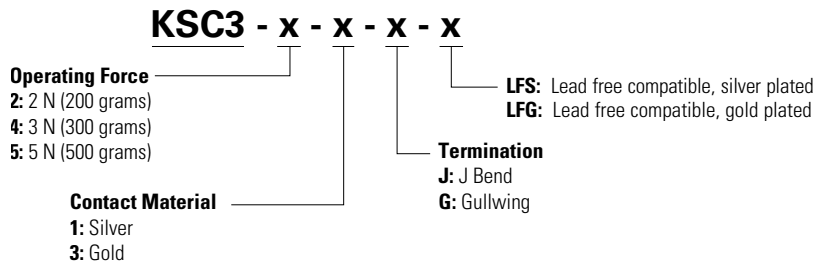

Liability Limitation

This datasheet does not provide enough information for applications that require a certain level of quality or safety such as automotive, medical systems, or safety equipment. Please contact customer service for the contractual specification package.

Disclaimer Notice - Information furnished is believed to be accurate and reliable. However, users should independently evaluate the suitability of and test each product selected for their own applications. Littelfuse products are not designed for, and may not be used in, all applications. Read complete Disclaimer Notice at <http://www.littelfuse.com/disclaimer-electronics>.

OUR CERTIFICATE

DiGi provide top-quality products and perfect service for customer worldwide through standardization, technological innovation and continuous improvement. DiGi through third-party certification, we stricly control the quality of products and services. Welcome your RFQ to

Email: Info@DiGi-Electronics.com



Tel: +00 852-30501935

RFQ Email: Info@DiGi-Electronics.com

DiGi is a global authorized distributor of electronic components.