

MLX90364LVS-ADD-203-RE Datasheet

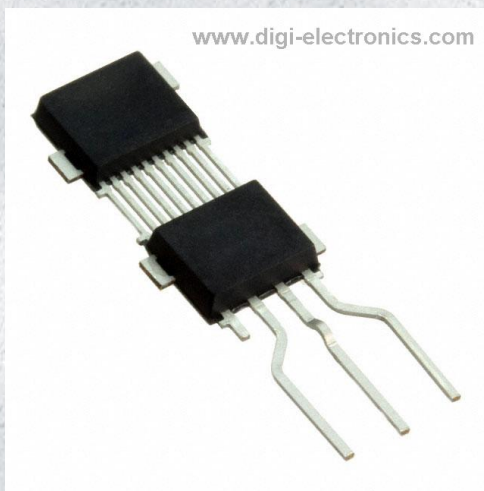

<https://www.DiGi-Electronics.com>

DiGi Electronics Part Number	MLX90364LVS-ADD-203-RE-DG
Manufacturer	Melexis Technologies NV
Manufacturer Product Number	MLX90364LVS-ADD-203-RE
Description	SENSOR ROTARY 360DEG PC PIN
Detailed Description	Hall Effect Sensor Linear, Rotary Position External Magnet, Not Included PC Pin

This model MLX90364LVS-ADD-203-RE is available at DiGi Electronics.

DiGi Electronics offers a global database of semiconductor and electronic component datasheets.

We welcome your inquiries regarding pricing, lead time, or other product-related questions.

 [Request a Quote](#)

 [Datasheet Search](#)



Tel: +00 852-30501935

RFQ Email: Info@DiGi-Electronics.com

DiGi is a global authorized distributor of electronic components.

Purchase and inquiry

Manufacturer Product Number:

MLX90364LVS-ADD-203-RE

Series:

Triaxis®

For Measuring:

Linear, Rotary Position

Rotation Angle - Electrical, Mechanical:

0° ~ 360°, Continuous

Output:

Analog, PWM

Actuator Type:

External Magnet, Not Included

Resistance Tolerance:

-

Mounting Type:

Through Hole

Operating Temperature:

-40°C ~ 150°C

Qualification:

AEC-Q100

Supplier Device Package:

4-DMP

Manufacturer:

Melexis Technologies NV

Product Status:

Active

Technology:

Hall Effect

Linear Range:

-

Output Signal:

-

Linearity:

±2.5°

Voltage - Supply:

4.5V ~ 5.5V

Termination Style:

PC Pin

Grade:

Automotive

Package / Case:

4-SIP Module, Formed Leads

Base Product Number:

MLX90364

Environmental & Export classification

RoHS Status:

ROHS3 Compliant

REACH Status:

REACH Unaffected

HTSUS:

8542.39.0001

Moisture Sensitivity Level (MSL):

3 (168 Hours)

ECCN:

EAR99

MLX90364 Triaxis® Position Sensor

Datasheet

Features and Benefits

- Absolute Rotary & Linear Position Sensor IC
- Robust Dual Mold Package (DMP-4) feat. up to 4 Decoupling Capacitors (ESD/EMC)
- Reliable NoPCB Module Integration
- Triaxis® Hall Technology
- Simple Magnetic Design
- Programmable Transfer Characteristic (Multi-Points – Piece-Wise-Linear)
- Selectable Output Mode: Analog (Ratiometric) – Pulse Width Modulation (PWM)
- 12 bit Resolution - 10 bit Thermal Accuracy
- Open/Short Diagnostics
- On Board Diagnostics
- Over-Voltage Protection
- Under-Voltage Detection
- 48 bit ID Number option
- Automotive Temperature Range
- AEC-Q100 & AEC-Q200 Qualified
- DMP-4 RoHS Compliant
- Output Thermal Offset correction

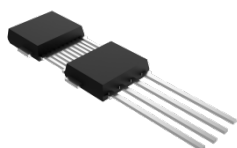

DMP-4

Applications

- Absolute Rotary Position Sensor
- Absolute Linear Position Sensor
- EGR Valve Position Sensor
- Turbo Actuator
- Throttle Position Sensor
- Clutch, Shift & Fork Position Sensor
- Ride Height Position Sensor
- Float Level Sensor

Description

The MLX90364 Triaxis® Position Sensor Assembly is a high accuracy linear and angular position sensor which eliminates need for inclusion of a printed circuit board (PCB) within sensing modules.

This device is based on a Dual Mold Package (DMP-4) construction, which integrates a Triaxis position sensing die together with the decoupling capacitors necessary to meet the strenuous ESD and EMC requirements. No PCB is needed.

The Triaxis position sensing die is nothing but the one used for the MLX90365 in conventional surface-mount packages (SOIC-8 and TSSOP-16).

Similarly to other Triaxis products, the MLX90364 is sensitive to the flux density applied orthogonally and parallel to the IC surface i.e. the 3 components of the flux density applied to the IC (i.e. B_x, B_y and B_z). This allows the MLX90364 with the correct magnetic circuit to decode the absolute position of any moving magnet (e.g. rotary position from 0 to 360 Degrees or linear displacement, stroke).

MLX90364 reports a programmable ratiometric analog output signal compatible with any resistive potentiometer or programmable linear Hall sensor. Through programming, the MLX90364 provides also a digital PWM (Pulse Width Modulation) output characteristic.

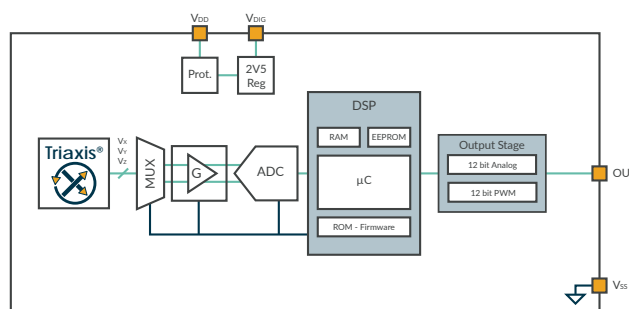

Contents

Features and Benefits.....	1
Applications	1
Description	1
1. Ordering Information	5
2. Functional Diagram	8
3. Glossary of Terms	8
4. Pinout	9
5. Absolute Maximum Ratings.....	9
6. Electrical Specification.....	10
7. Timing Specification.....	13
7.1. ANALOG OUTPUT	13
7.2. PWM OUTPUT	14
8. Accuracy Specification.....	15
8.1. Magnetic Accuracy.....	15
8.1.1. Normal Magnetic range: $20 \text{ mT} \leq B < 70 \text{ mT}$	15
8.1.2. Extended Range #1 : $15 \text{ mT} \leq B < 20 \text{ mT}$	16
8.1.3. Extended Range #2: $10 \text{ mT} \leq B < 15 \text{ mT}$	16
8.2. ANALOG OUTPUT	17
8.3. PWM OUTPUT	18
9. Magnetic Specification	20
10. CPU & Memory Specification	20
11. Traceability Information	21
12. End-User Programmable Items	21
13. Description of End-User Programmable Items.....	23
13.1. Output modes	23
13.1.1. OUT mode	23
13.1.2. Analog Output Mode	24
13.1.3. PWM Output Mode	24
13.2. Output Transfer Characteristic	25
13.2.1. Enable scaling Parameter (only for LNR type 4 pts)	26
13.2.2. CLOCKWISE Parameter	26

MLX90364 Triaxis® Position Sensor

Datasheet

13.2.3. Discontinuity Point (or Zero Degree Point)	26
13.2.4. 4-Pts LNR Parameters	26
13.2.5. 17-Pts LNR Parameters	27
13.2.6. CLAMPING Parameters	28
13.2.7. Thermal Output Offset correction (AxE version only).....	28
13.3. Identification	29
13.4. Lock	29
13.5. Sensor Front-End	30
13.5.1. MAPXYZ	30
13.5.2. SMISM, k and SEL_k Parameters	30
13.5.3. GAINMIN and GAINMAX Parameters	31
13.6. Filter	31
13.6.1. Hysteresis Filter.....	31
13.6.2. FIR Filters.....	31
13.7. Programmable Diagnostic Settings.....	32
13.7.1. DIAG mode	32
13.7.2. DIAG Level.....	32
13.7.3. Field Strength Diagnostic.....	32
13.7.4. PWM Diagnostic.....	33
13.7.5. Diagnostic Features.....	33
13.8. EEPROM endurance.....	33
14. Self Diagnostic	34
15. Built-in Capacitors and Recommended Application Diagrams	38
16. Standard information regarding manufacturability of Melexis products with different soldering processes	39
17. ESD Precautions.....	39
18. Package Information.....	40
18.1. DMP-4 Package	40
18.1.1. DMP-4 - Package Outline Dimensions (POD) – Straight Leads.....	40
18.1.2. DMP-4 - Package Outline Dimensions (POD) – STD1 2.54	41
18.1.3. DMP-4 - Package Outline Dimensions (POD) – STD2 2.54	41
18.1.4. DMP-4 - Package Outline Dimensions (POD) – STD4 2.54	42
18.1.5. DMP-4 - Marking.....	42

MLX90364 Triaxis® Position Sensor

Datasheet



18.1.6. DMP-4 - Sensitive Spot Positioning	43
18.1.7. DMP-4 - Angle detection	44
19. Disclaimer	45
20. Contact	45

1. Ordering Information

Product Code	Temperature	Package	Option Code	Packing Form	Comment
MLX90364	L	VS	ADB-200	RE/RX	Not recommended for new design
MLX90364	L	VS	ADB-201	RE/RX	Not recommended for new design
MLX90364	L	VS	ADB-203	RE/RX	Not recommended for new design
MLX90364	L	VS	ADB-208	RE/RX	Not recommended for new design
MLX90364	L	VS	ADB-250	RE/RX	Not recommended for new design
MLX90364	L	VS	ADB-251	RE/RX	Not recommended for new design
MLX90364	L	VS	ADB-253	RE/RX	Not recommended for new design
MLX90364	L	VS	ADB-258	RE/RX	Not recommended for new design
MLX90364	L	VS	ADD-200	RE/RX	Not recommended for new design
MLX90364	L	VS	ADD-201	RE/RX	Not recommended for new design
MLX90364	L	VS	ADD-203	RE/RX	Not recommended for new design
MLX90364	L	VS	ADD-208	RE/RX	Not recommended for new design
MLX90364	L	VS	ADD-250	RE/RX	Not recommended for new design
MLX90364	L	VS	ADD-251	RE/RX	Not recommended for new design
MLX90364	L	VS	ADD-253	RE/RX	Not recommended for new design
MLX90364	L	VS	ADD-258	RE/RX	Not recommended for new design
MLX90364	L	VS	ADD-300	RE/RX	Not recommended for new design
MLX90364	L	VS	ADD-301	RE/RX	Not recommended for new design
MLX90364	L	VS	ADD-303	RE/RX	Not recommended for new design
MLX90364	L	VS	ADD-308	RE/RX	Not recommended for new design
MLX90364	L	VS	ADD-400	RE/RX	Not recommended for new design
MLX90364	L	VS	ADD-401	RE/RX	Not recommended for new design
MLX90364	L	VS	ADD-403	RE/RX	Not recommended for new design
MLX90364	L	VS	ADD-408	RE/RX	Not recommended for new design
MLX90364	L	VS	ADE-200	RE/RX	Not recommended for new design
MLX90364	L	VS	ADE-201	RE/RX	Not recommended for new design
MLX90364	L	VS	ADE-203	RE/RX	Not recommended for new design

MLX90364 Triaxis® Position Sensor

Datasheet

Product Code	Temperature	Package	Option Code	Packing Form	Comment
MLX90364	L	VS	ADE-208	RE/RX	Not recommended for new design
MLX90364	L	VS	AED-200	RE/RX	
MLX90364	L	VS	AED-201	RE/RX	Not recommended for new design
MLX90364	L	VS	AED-203	RE/RX	
MLX90364	L	VS	AED-208	RE/RX	
MLX90364	L	VS	AED-250	RE/RX	
MLX90364	L	VS	AED-251	RE/RX	Not recommended for new design
MLX90364	L	VS	AED-253	RE/RX	
MLX90364	L	VS	AED-258	RE/RX	
MLX90364	L	VS	AED-300	RE/RX	
MLX90364	L	VS	AED-301	RE/RX	Not recommended for new design
MLX90364	L	VS	AED-303	RE/RX	
MLX90364	L	VS	AED-308	RE/RX	
MLX90364	L	VS	AED-400	RE/RX	
MLX90364	L	VS	AED-401	RE/RX	Not recommended for new design
MLX90364	L	VS	AED-403	RE/RX	
MLX90364	L	VS	AED-408	RE/RX	
MLX90364	L	VS	AEE-200	RE/RX	
MLX90364	L	VS	AEE-201	RE/RX	Not recommended for new design
MLX90364	L	VS	AEE-203	RE/RX	
MLX90364	L	VS	AEE-208	RE/RX	

MLX90364 Triaxis® Position Sensor

Datasheet

Legend:

Temperature Code:	L: from -40 Deg.C to 150 Deg.C
Package Code:	“VS” for DMP-4
Option Code:	<p>Axx-xxx: die version</p> <p>ADx-xxx: not recommended for new design</p> <p>AED-xxx: standard version</p> <p>AEE-xxx: standard version with thermal offset correction</p> <p>xxx-123:</p> <p>12: Capacitances configuration see section 15.1</p> <p>3: Trim-and-Form for DMP-4</p> <ul style="list-style-type: none"> ▪ 0: Standard straight leads. See section 18.1.1 ▪ 1: Trim-and-Form STD1 2.54. See section 18.1.2 (not recommended for new design, prefer STD4 2.54) ▪ 3: Trim-and-Form STD2 2.54. See section 18.1.3 ▪ 8: Trim-and-Form STD4 2.54. See section 18.1.4
Packing Form:	<p>RE for Reel (face-up)</p> <p>RX for Reel (face down)</p> <p>SP Sample Pack</p>
Ordering Example:	MLX90364LVS-AED-201-RE

2. Functional Diagram

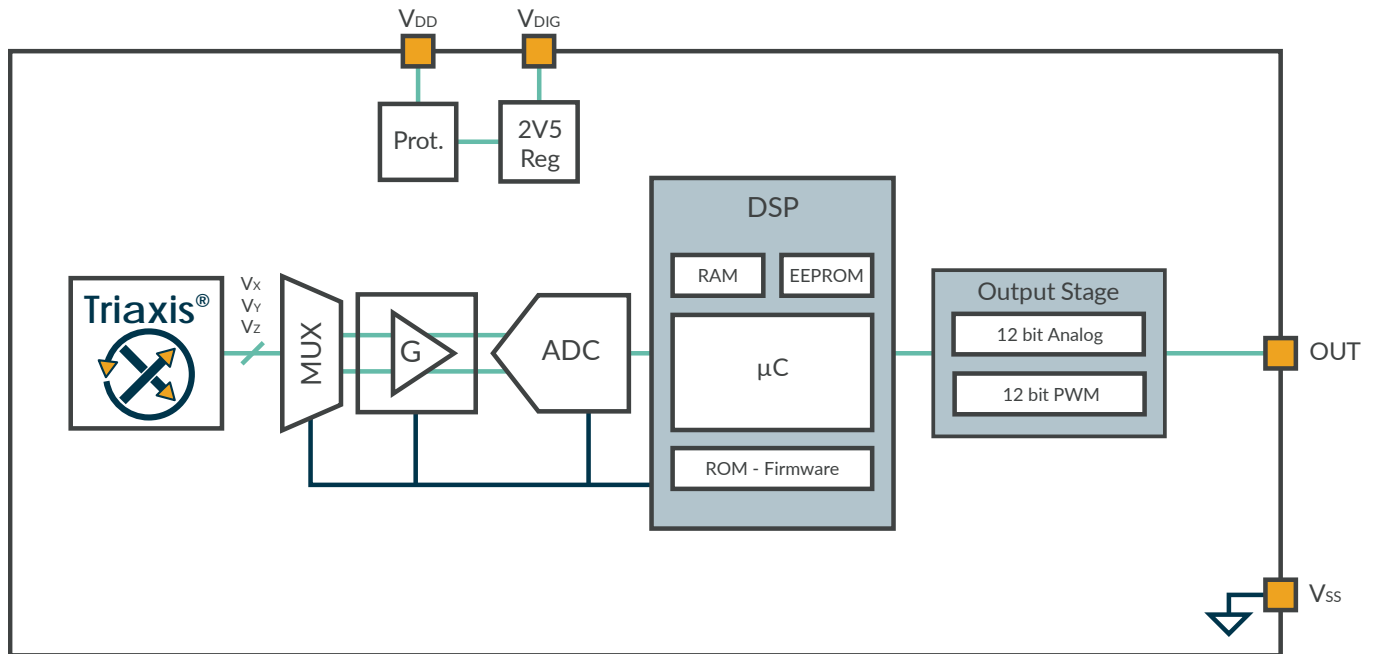

Figure 1 – Block Diagram

3. Glossary of Terms

Gauss (G), Tesla (T)	Units for the magnetic flux density - 1 mT = 10 G
TC	Temperature Coefficient (in ppm/Deg.C.)
NC	Not Connected
ADC	Analog-to-Digital Converter
LSB	Least Significant Bit
MSB	Most Significant Bit
DNL	Differential Non-Linearity
INL	Integral Non-Linearity
RISC	Reduced Instruction Set Computer
ASP	Analog Signal Processing
DSP	Digital Signal Processing
ATAN	Trigonometric function: arctangent (or inverse tangent)
IMC	Integrated Magneto-Concentrator (IMC®)

CoRDIC	Coordinate Rotation Digital Computer (i.e. iterative rectangular-to-polar transform)
EMC	Electro-Magnetic Compatibility
FE	Falling Edge
RE	Rising Edge
FW	Firmware
HW	Hardware
PWM	Pulse Width Modulation
%DC	Ratio T_{on} / T_{period} where T_{on} is the high state duration and T_{period} is the duration of 1 pwm period
MT3V	More Than 3V Condition
MT4V	More Than 4V Condition
LSD	Low Side Driver = Open drain N
PP	Push-Pull

Table 1 – Glossary of Terms

4. Pinout

PIN	Pin Name
1	VSS (Ground)
2	VDD
3	OUT
4	VSS (Ground)

5. Absolute Maximum Ratings

Parameter	Value
Supply Voltage, VDD (overvoltage)	+ 24 V
Reverse Voltage Protection	– 12 V (breakdown at -14 V)
Positive Output Voltage	+ 18 V (breakdown at 24 V)
Output Current (I _{OUT})	+ 30 mA (in breakdown)
Reverse Output Voltage	– 0.3 V
Reverse Output Current	– 50 mA (in breakdown)
Operating Ambient Temperature Range, T _A	– 40 ... + 150 Deg.C
Storage Temperature Range, T _S	– 40 ... + 150 Deg.C
Magnetic Flux Density	± 1 T

Exceeding the absolute maximum ratings may cause permanent damage. Exposure to absolute maximum-rated conditions for extended periods may affect device reliability. These max ratings are guaranteed by mean of a qualification test where the device is supplied at 24V for 48h, the Output voltage is supplied at 18V for 48h and the device is reversely supplied at -12V for 1h.

6. Electrical Specification

DC Operating Parameters at Nominal Supply Voltage (unless otherwise specified) and for T_A as specified by the Temperature suffix (L).

Parameter	Symbol	Test Conditions	Min	Typ	Max	Units
Nominal Supply Voltage	VDD		4.5	5	5.5	V
Supply Current ⁽¹⁾	I _{DD}	Power saving Enabled Power saving Disabled		6 8	10 ⁽²⁾ 12	mA
Supply Current (PWM mode) ⁽³⁾	I _{peak}	Peak current in PWM mode 7		30	40	mA
Isurge Current ⁽⁴⁾	I _{surge}				20	mA
Power-On reset (rising)	HPOR_LH	Refer to internal voltage Vdig	2	2.25	2.5	V
Power-On reset Hysteresis	HPOR_Hyst		50		200	mV
Start-up Level (rising)	MT4V LH		3.8	4.0	4.2	V
Start-up Hysteresis	MT4V Hyst		50		200	mV
PTC Entry Level (rising)	MT7V_LH		5.8	6.2	6.6	V
PTC Entry Level Hysteresis	MT7V_Hyst		50		200	mV
Output Short Circuit Current	I _{SHORT}	V _{out} = 0 V V _{out} = 5 V V _{out} = 18 V (T_A = 25 Deg.C)			15 15 18	mA mA mA
Output Load Analog	R _L	Pull-down to Ground Pull-up to 5V	4.7 ⁽⁵⁾ 4.7 ⁽⁵⁾	10 10		kΩ kΩ
Output Load PWM	R _{L_PWM}	Pull-down to Ground Pull-up to 5V	1 1			kΩ kΩ

¹ For the dual version, the supply current is multiplied by 2.

² To reach 10mA, the power saving option should be enabled. This option switches off and on internal blocks dynamically. It can be disabled in case of extreme emission requirements or if an analog output is required with a resistor on either supply or output line.

³ This current is due to the charge of output capacitors in PWM push-pull mode.

⁴ The specified value is valid during early start-up time only; the current might dynamically exceed the specified value, shortly, during the Start-up phase.

⁵ The minimum specified value is mandatory to reach passive diagnostic output levels. A minimum 1k load resistor can be used otherwise.

MLX90364 Triaxis® Position Sensor

Datasheet

Parameter	Symbol	Test Conditions	Min	Typ	Max	Units
Analog Saturation Output Level	Vsat_lo	Pull-up load $R_L \geq 10 \text{ k}\Omega$ to 5 V		0.5	2	%VDD
		Pull-up load $R_L \geq 5 \text{ k}\Omega$ to 18V		2	3	
	Vsat_hi	Pull-down load $R_L \geq 5 \text{ k}\Omega$	95	97		%VDD
		Pull-down load $R_L \geq 10 \text{ k}\Omega$	97.5	98.5		
Digital Saturation Level	Vo_min	Pull-up load $R_{L_PWM} \leq 1 \text{ k}\Omega$ to 5V	98			%VPU ⁽⁶⁾
Open drain Output (R_{L_PWM} to VPU ⁽⁶⁾)		Pull-up load $R_{L_PWM} \leq 1 \text{ k}\Omega$ to 14V	95			
		Pull-up load $R_{L_PWM} \leq 1 \text{ k}\Omega$ to 18V	90			
		Pull-up load $R_{L_PWM} \leq 5.6 \text{ k}\Omega$ to 5V	96			
		Pull-up load $R_{L_PWM} \leq 5.6 \text{ k}\Omega$ to 14V	85			
		Pull-up load $R_{L_PWM} \leq 5.6 \text{ k}\Omega$ to 18V	73			
Active Diagnostic Output Level	Dsat_lo	Pull-up load $R_L \geq 10 \text{ k}\Omega$ to 5V		0.5	2	%VDD
		Pull-up load $R_L \geq 5 \text{ k}\Omega$ to 18V		2	3	
Digital Saturation Output Level	Dsat_hi	Pull-down load $R_L \geq 5 \text{ k}\Omega$	95	97		%VDD
		Pull-down load $R_L \geq 10 \text{ k}\Omega$	97.5	98.5		
Passive Diagnostic Output Level (Broken Track Diagnostic) ⁽⁷⁾	BVssPD	Broken Vss &				%VDD
		Pull-down load $R_L \geq 5 \text{ k}\Omega$	95			
		Pull-down load $R_L \geq 10 \text{ k}\Omega$	97.5			
	BVssPU	Broken Vss &		99.5	100	
Pull-up load $R_L \geq 1 \text{ k}\Omega$						
BVDDPD	Broken VDD &			0	0.5	%VDD
		Pull-down load $R_L \geq 1 \text{ k}\Omega$				
BVDDPU	Broken VDD &				2	%VDD
		Pull-up load $R_L \geq 5 \text{ k}\Omega$				
Digital output Ron	Ron	Diag_Low	15		30	Ω
		Diag_Hi	120		300	
Clamped Output Level	Clamp_lo	Programmable	0		100	%VDD ⁽⁸⁾
	Clamp_hi	Programmable	0		100	%VDD ⁽⁸⁾

⁶ VPU being the pull-up voltage connected externally to the output through the pull-up resistor⁷ For detailed information on diagnostics, see also section Self Diagnostic⁸ Clamping levels need to be considered vs the saturation of the output stage (see Vsat_lo and Vsat_hi)

MLX90364 Triaxis® Position Sensor

Datasheet

As an illustration of the previous table, the MLX90364 fits the typical classification of the output span described on the Figure 2.

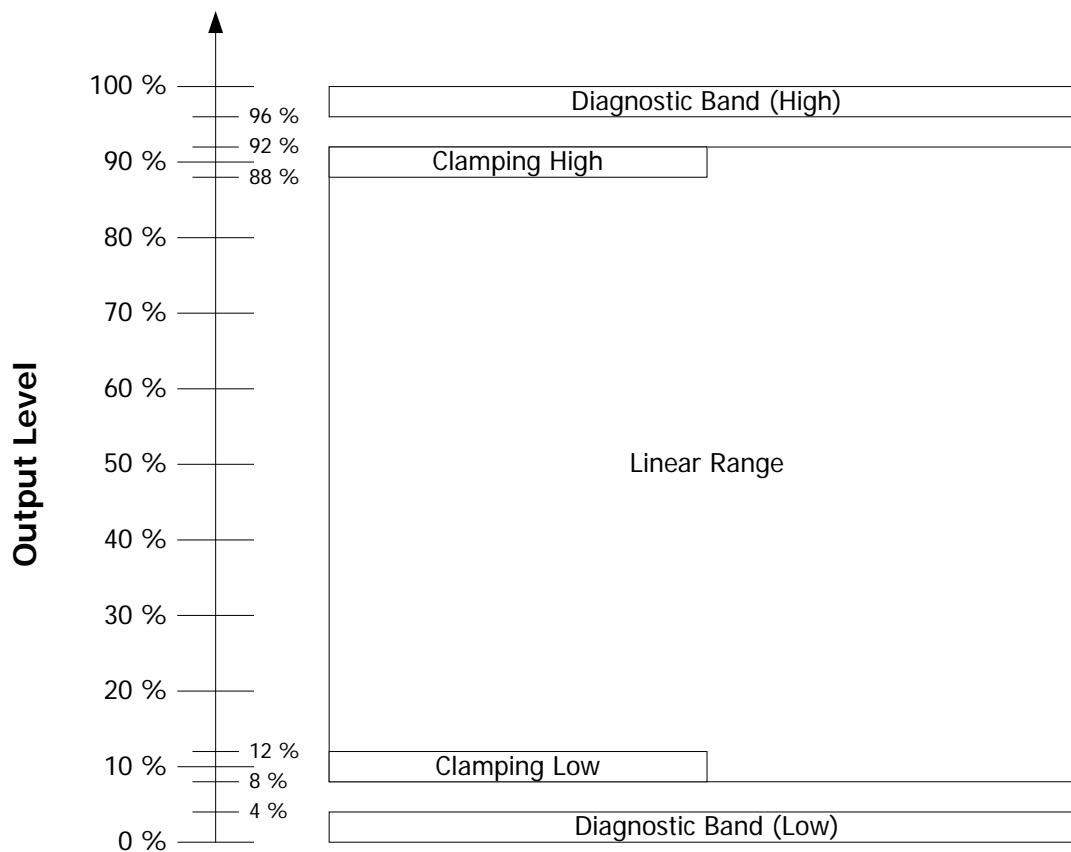

Figure 2 – Example of Output Span Classification for typical application

7. Timing Specification

7.1. ANALOG OUTPUT

DC Operating Parameters at Nominal Supply Voltage (unless otherwise specified) and for TA as specified by the Temperature suffix (L).

Parameter	Symbol	Test Conditions	Min	Typ	Max	Units
Main Clock Frequency	Ck	All contributors (trimming accuracy, supply voltage, thermal and ageing)	12.6	13.3	14	MHz
Main Clock Frequency Thermal Drift	ΔT_{Ck}				$\pm 3\%$	Ck _{NOM}
Refresh Rate	tper		275	290	305	μs
Step Response Time	Ts	Filter=0 ⁽⁹⁾		657 ⁽¹⁰⁾	896	μs
		Filter=1		876	1195	
		Filter=2		1095	1494	
Watchdog	Twd		114.5	118	121.5	ms
Phase Shift	PS	Filter=0		0.16		Deg/Hz
Start-up Cycle	Tsu	Analog OUT Slew-rate excluded			5	ms
Analog OUT Slew-rate		Analog Mode 1	25	37		V/ms

⁹ See section 13.6 for details concerning Filter parameter

¹⁰ This represents a theoretical average response time

7.2. PWM OUTPUT

DC Operating Parameters at Nominal Supply Voltage $V_{DD} = V_{PU}$ (unless otherwise specified) and for T_A as specified by the Temperature suffix (L).

Parameter	Symbol	Test Conditions	Min	Typ	Max	Units
PWM Frequency	F_{PWM}	Programmable Range (PWM Output Enabled)	100		1000	Hz
		Initial Tolerance (25 Deg.C)			± 2%	FPWM
		After EOL tuning (25 Deg.C)			± 1%	FPWM
		Thermal/Lifetime drift			± 3%	FPWM
Start-up Cycle	Tsu	PWM OUT Slew-rate excluded 100Hz		11.8	13	ms
		250Hz		5.8	7	
		1000Hz		5.8	7	
Digital Output Rise Time		LOW SIDE DRIVER – Mode 5 RL = 1 kΩ PU		80	130	μs
		PUSH-PULL – Mode 7 RL = 1 kΩ PU		27	50	μs
Digital Output Fall Time		LOW SIDE DRIVER – Mode RL = 1 kΩ PU		27	50	μs
		PUSH-PULL – Mode 7 RL = 1 kΩ PU		27	50	μs

8. Accuracy Specification

8.1. Magnetic Accuracy

8.1.1. Normal Magnetic range: $20 \text{ mT} \leq B < 70 \text{ mT}$

DC Operating Parameters at Nominal Supply Voltage (unless otherwise specified) and for T_A as specified by the Temperature suffix (L).

Parameter	Symbol	Test Conditions	Min	Typ	Max	Units
Thermal Offset Drift #1 ⁽¹¹⁾ at the DSP input (excl. DAC and output stage)		T_A from -40 to 125 Deg.C	-60		+60	LSB ₁₅
		T_A from -40 to 150 Deg.C	-90		+90	LSB ₁₅
Thermal Drift of Sensitivity Mismatch ⁽¹²⁾		XY axis	-0.5		+0.5	%
		XZ (YZ) axis	-1		+1	
Magnetic Angle phase error		$T_A = 25 \text{ Deg.C} - \text{XY axis}$	-0.3		0.3	Deg.
		$T_A = 25 \text{ Deg.C} - \text{XZ axis}$	-2		2	
		$T_A = 25 \text{ Deg.C} - \text{YZ axis}$	-2		2	
Thermal Drift of Magnetic Angle phase error		XY axis, XZ (YZ) axis		0.01		Deg.
XY – Intrinsic Linearity Error ⁽¹³⁾	Le	$T_A = 25 \text{ Deg.C} - \text{factory trim.}$ “SMISM”	-1		1	Deg.
XZ - Intrinsic Linearity Error ⁽¹³⁾	Le	$T_A = 25 \text{ Deg.C} - \text{“k” trimmed for}$ XZ	-2.5	± 1.25	+2.5	Deg.
YZ - Intrinsic Linearity Error ⁽¹³⁾	Le	$T_A = 25 \text{ Deg.C} - \text{“k” trimmed for}$ YZ	-2.5	± 1.25	+2.5	Deg.

¹¹ For instance, in case of a rotary position sensor application, Thermal Offset Drift #1 equal $\pm 60\text{LSB}_{15}$ yields to max. $\pm 0.3 \text{ Deg.}$ angular error for the computed angular information (output of the DSP). This is only valid if $k = 1$.

¹² For instance, in case of a rotary position sensor application, Thermal Drift of Sensitivity Mismatch equal $\pm 0.5\%$ yields to max. $\pm 0.15 \text{ Deg.}$ angular error for the computed angular information (output of the DSP). See “MLX90364 Front-End Application Note” for more details.

¹³ The Intrinsic Linearity Error refers to the IC itself (offset, sensitivity mismatch, orthogonality) taking into account an ideal rotating field for B_x and B_y . Once associated to a practical magnetic construction and the associated mechanical and magnetic tolerances, the output linearity error increases. However, it can be improved with the multi-point end-user calibration. The intrinsic Linearity Error for Magnetic angle $\angle XZ$ and $\angle YZ$ can be reduced through the programming of the k factor.

MLX90364 Triaxis® Position Sensor

Datasheet

Parameter	Symbol	Test Conditions	Min	Typ	Max	Units
Noise pk-pk ⁽¹⁴⁾		Filter = 0, 40mT		0.10	0.2	Deg.
		Filter = 1 (recommended), 30mT		0.10	0.2	
		Filter = 2, 20mT		0.10	0.2	

8.1.2. Extended Range #1 : $15 \text{ mT} \leq B < 20 \text{ mT}$

DC Operating Parameters at nominal supply voltage (unless otherwise specified) and for T_A as specified by the Temperature suffix (L).

Parameter	Symbol	Test Conditions	Min	Typ	Max	Units
Offset on Raw Signals X,Y,Z	X0,Y0,Z0	TA = 25 Deg.C.	-120		+120	LSB ₁₅
Thermal Offset Drift #1 at the DSP input (excl. DAC and output stage)		TA from -40 to 125 Deg.C	-120		+120	LSB ₁₅
		TA from -40 to 150 Deg.C	-180		+180	
Noise pk-pk		Filter 0			75	LSB ₁₅

In case of the use of the MLX90364 in those extended ranges, Melexis recommends validating the headroom of the internal diagnostic and if necessary to disable the diagnostic mode related to the amplitude of the flux strength and/or amplification factor of the device.

8.1.3. Extended Range #2: $10 \text{ mT} \leq B < 15 \text{ mT}$

DC Operating Parameters at nominal supply voltage (unless otherwise specified) and for T_A as specified by the Temperature suffix (L).

Parameter	Symbol	Test Conditions	Min	Typ	Max	Units
Offset on Raw Signals X,Y,Z	X0,Y0,Z0	TA = 25 Deg.C.	-180		+180	LSB ₁₅
Thermal Offset Drift #1 at the DSP input (excl. DAC and output stage)		TA from -40 to 125 Deg.C	-180		+180	LSB ₁₅
		TA from -40 to 150 Deg.C	-270		+270	
Noise pk-pk		Filter 0			112	LSB ₁₅

In case of the use of the MLX90364 in those extended ranges, Melexis recommends to validate the headroom of the internal diagnostic and if necessary to disable the diagnostic mode related to the amplitude of the flux strength and/or amplification factor of the device.

¹⁴ Noise pk-pk (peak-to-peak) is here intended as 6 times the Noise standard Deviation. The application diagram used is described in the recommended wiring. For detailed information, refer to section Filter in application mode (Section 13.6).

8.2. ANALOG OUTPUT

DC Operating Parameters at nominal supply voltage (unless otherwise specified) and for TA as specified by the Temperature suffix (L).

Parameter	Symbol	Test Conditions	Min	Typ	Max	Units
ADC Resolution on the raw signals sine and cosine ⁽¹⁵⁾	RADC			15		bits
Thermal Offset Drift #2 (DAC and Output Stage)			-0.2		+0.2	%VDD
Analog Output Resolution	RDAC	12b DAC (Theoretical, Noise free)		0.025		%VDD/ LSB ₁₂
		INL (before EOL calibration)	-4		+4	LSB ₁₂
		DNL	0.05	1	3	LSB ₁₂
Output stage Noise		Clamped Output		0.05	0.075	%VDD
Ratiometry Error		4.5V ≤ VDD ≤ 5.5V	-0.05		+0.05	%VDD
		LT4V ≤ VDD ≤ MT7V	-0.1		+0.1	%VDD

¹⁵ 16 bits corresponds to 15 bits + sign. Internal computation is performed using 16 bits.

8.3. PWM OUTPUT

DC Operating Parameters at nominal supply voltage (unless otherwise specified) and for TA as specified by the Temperature suffix (L).

Parameter	Symbol	Test Conditions	Min	Typ	Max	Units
PWM Output Resolution	RPWM	12 bits		0.025		%DC/ LSB
PWM % DC Jitter ⁽¹⁶⁾	JDC	LOW SIDE DRIVER – Mode5 200Hz, RL = 1 kΩ PU		±0.015	±0.075	%DC
		PUSH-PULL – Mode7 200Hz, RL = 1 kΩ PU			±0.075	%DC
PWM Freq Jitter ⁽¹⁶⁾	JPWM	LOW SIDE DRIVER – Mode5 100-1000 Hz, RL = 1 kΩ PU		±0.05	±0.2	Hz
		PUSH-PULL – Mode7 100-1000 Hz, RL = 1 kΩ PU		±0.05	±0.2	Hz
PWM % DC thermal drift		LOW SIDE DRIVER – Mode5 100Hz, RL = 1 kΩ PU		±0.02	±0.03	%DC
		200Hz, RL = 1 kΩ PU		±0.02	±0.03	%DC
		PUSH-PULL – Mode7 100Hz, RL = 1 kΩ PU		±0.02	±0.03	%DC
		200Hz, RL = 1 kΩ PU		±0.02	±0.03	%DC

¹⁶ Jitter is defined by $\pm 3 \sigma$ for 1000 successive acquisitions with clamped output.

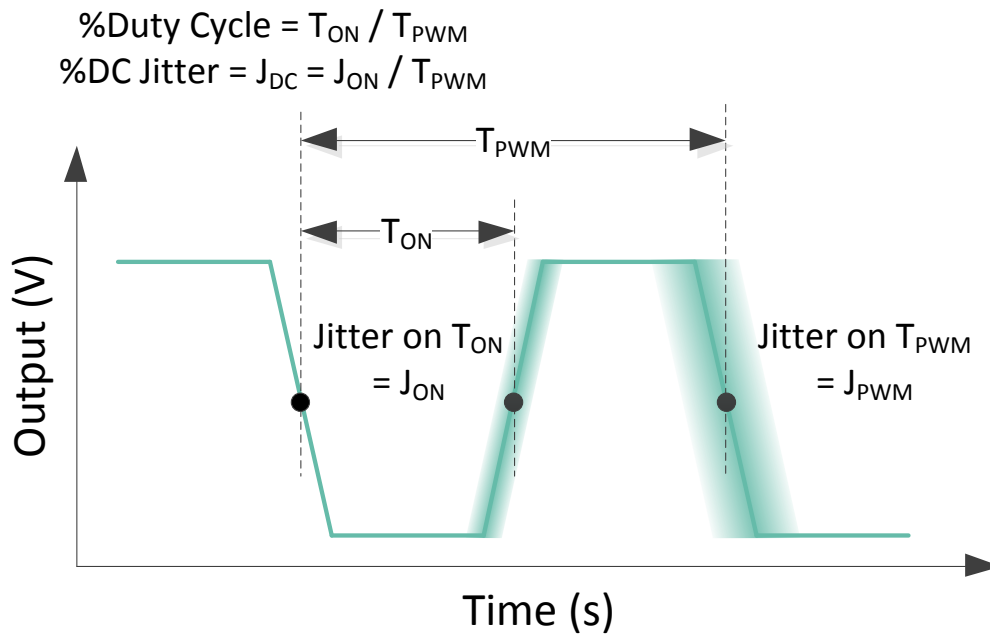

Parameter	Symbol	Test Conditions
PWM T_{ON} , T_{PWM}	T_{ON} T_{PWM}	Trigger level = 50 % $V_{\text{push-pull}}$
Rise time, Fall time		10% and 90% of amplitude
Jitter	J_{ON} J_{PWM}	$\pm 3 \sigma$ for 1000 successive acquisitions
Duty Cycle	% DC	$T_{\text{ON}} / T_{\text{PWM}}$

Figure 3 – MLX90364 PWM measurement conditions.

9. Magnetic Specification

DC Operating Parameters at Nominal Supply Voltage (unless otherwise specified) and for TA as specified by the Temperature suffix (L).

Parameter	Symbol	Test Conditions	Min	Typ	Max	Units
Magnetic Flux Density	$B_X, B_Y^{(17)}$	$\sqrt{B_X^2 + B_Y^2}$			70 ⁽¹⁸⁾	mT
Magnetic Flux Density	B_Z				126	mT
Magnetic Flux Norm	Norm	$\sqrt{B_X^2 + B_Y^2 + (B_Z/kmin)^2}$	20 ⁽¹⁹⁾			mT
IMC Gain in X and Y ⁽²⁰⁾	GainIMC _{XY}		1.2	1.4	1.8	
IMC Gain in Z ⁽²⁰⁾	GainIMC _Z		1.1		1.3	
k factor	k	GainIMC _{XY} / GainIMC _Z	1	1.2	1.5	
Magnet Temperature Coefficient	TCm		-2400		0	ppm/Deg.C

10. CPU & Memory Specification

The DSP is based on a 16 bit RISC μ Controller. This CPU provides 2.5 Mips while running at 10 MHz.

Parameter	Symbol	Test Conditions	Min	Typ	Max	Units
ROM				10		KB
RAM				384		B
EEPROM				128		B

¹⁷ The condition must be fulfilled for at least one field B_X or B_Y .

¹⁸ Above 70 mT, the IMC[®] starts saturating yielding to an increase of the linearity error.

¹⁹ Below 20 mT, the performances slightly degrade due to a reduction of the signal-to-noise ratio, signal-to-offset ratio.

²⁰ This is the magnetic gain linked to the Integrated Magneto Concentrator structure. This is the overall variation. Within one lot, the part to part variation is typically $\pm 10\%$ versus the average value of the IMC gain of that lot.

11. Traceability Information

Every device contains a unique ID that is programmed by Melexis in the EEPROM. Melexis strongly recommends storing this value during the EOL (End-Of-Line) programming to ensure full traceability of the final product.

These parameters shall never be erased during the EOL programming.

Parameter	Comments	Default Values	# bit
MELEXISID1	Melexis identification reference	MLX	16
MELEXISID2	Melexis identification reference	MLX	16
MELEXISID3	Melexis identification reference	MLX	16

12. End-User Programmable Items

Parameter	Comments	Standard	# bit
OUT mode	Define the output stage mode	1	3
DIAG mode	Diagnostic mode	7	3
DIAG Level	Diagnostic Level	0	1
MAPXYZ	Mapping fields for output angle	0	2
CLAMP_HIGH	Clamping High	50%	16
CLAMP_LOW	Clamping Low	50%	16
FILTER	Filter mode selection	0	2
SMISM	Sensitivity mismatch factor X,Y	MLX	15
k	Sensitivity mismatch factor X (Y) , Z	MLX	15
SEL_k	Affected signal component by k: B1 or B2 (in combination of MAPXYZ)	0	1
GAINMIN	Low threshold for virtual gain	00h	8
GAINMAX	High threshold for virtual gain	28h	8
GAINSATURATION	Gain Saturates on GAINMIN and GAINMAX	0h	1
FIELDTHRESH_Low	Field limit under which a fault is reported	10mT	8
FIELDTHRESH_High	Field limit above which a fault is reported	FFh	8
PWM	PWM function	0h	1

MLX90364 Triaxis® Position Sensor

Datasheet

Parameter	Comments	Standard	# bit
PWMPOL	PWM polarity	0h	1
PWMT	PWM Frequency (trimmed at 200Hz)	MLX	8
DC_FAULT	PWM Duty Cycle if Fault	1h	8
DC_FTL	PWM Duty Cycle if Field Strength Too Low	1h	8
DC_WEAK	PWM Duty Cycle if Weak Magnet	1h	8
WEAKMAGTHRESH	Weak Magnet threshold Byte (1LSB = 1mT)	0h	8
DP	Discontinuity point	0h	15
CW	Clock Wise	0h	1
FHYST	Hysteresis filter	0h	8
4POINTS	Selection of correction method 4 or 17 pts	1h	1
LNR_S0	4pts – Initial Slope	0 %/deg	16
LNR_A_X	4pts – AX Coordinate	0 deg	16
LNR_A_Y	4pts – AY Coordinate	10 %	16
LNR_A_S	4pts – AS Coordinate	0.22%/deg	16
LNR_B_X	4pts – BX Coordinate	360 deg	16
LNR_B_Y	4pts – BY Coordinate	100%	16
LNR_B_S	4pts – BS Coordinate	0 %/deg	16
LNR_C_X	4pts – CX Coordinate	360 deg	16
LNR_C_Y	4pts – CY Coordinate	100%	16
LNR_C_S	4pts – CS Coordinate	0 %/deg	16
LNR_D_X	4pts – DX Coordinate	360 deg	16
LNR_D_Y	4pts – DY Coordinate	100%	16
LNR_D_S	4pts – DS Coordinate	0 %/deg	16
W	17pts – Output angle range	0h	4
USERID1	Cust. ID reference	Bin1	16
USERID2	Cust. ID reference	203h(ADB) 204h(AxD) 205h(AxE)	16
USERID3	Cust. ID reference	MLX	16
LNR_Yn (n = 0, 1, 2 ..., 16)	17pts – Y-coordinate points	N/A	16

Parameter	Comments	Standard	# bit
DIAG Settings	16 Bit Diagnostics enabling	FDFh	16
CRC_DISABLE	Enable EERPOM CRC check (3131h= disable)	0h	16
MEMLOCK (AxD and AxE version only)	Write-protects USER/MLX EEPROM param.	0h	2
ANGLEOFSSLOPECOLD (AxE version only)	Temperature coefficient offset at cold temperatures	0h	8
ANGLEOFSSLOPEHOT (AxE version only)	Temperature coefficient offset at hot temperatures	0h	8

Melexis strongly recommends checking the User Identification data (Parameters USERID) during EOL programming.

13. Description of End-User Programmable Items

13.1. Output modes

13.1.1. OUT mode

Defines the Output Stage mode in application.

Output mode[2:0]	Type	Descriptions	Comments
0	Disable	Output HiZ	Not recommended
1	Analog	Analog Rail-to-Rail	Analog
5	Digital	open drain NMOS	PWM
6	Digital	open drain PMOS	PWM
7	Digital	Push-Pull	PWM

13.1.2. Analog Output Mode

The Analog Output Mode is a rail-to-rail and ratiometric output with a push-pull output stage configuration allows the use of a pull-up or pull-down resistor.

13.1.3. PWM Output Mode

If PWM output mode is selected, the output signal is a digital signal with Pulse Width Modulation (PWM). The PWM polarity is selected by the PWMPOL parameter:

- PWMPOL = 1 for a low level at 100%
- PWMPOL = 0 for a high level at 100%

The PWM frequency is selected by the PWMT parameter. The following table provides typical code for different target PWM frequency and for both low and high speed modes.

PWM F (Hz)	PWMT (LSB) @13.3MHz	PWM res. (μ s)	PWM res. (%)	PWM res. (bit)
100	44333	0.240	0.0024	15
250	17733	0.240	0.006	14
500	8866	0.240	0.012	13

Notes:

- A more accurate trimming can be performed to take into account initial tolerance of the main clock.
- The PWM frequency is subjected to the same tolerances as the main clock (see ΔT_{ck}).

13.2. Output Transfer Characteristic

There are 2 different possibilities to define the transfer function (LNR):

- With 4 arbitrary points (defined on X and Y coordinates) and 5 slopes
- With 17 equidistant points for which only the Y coordinates are defined.

Parameter	LNR type	Value	Unit
CLOCKWISE	Both	0 → CounterClockWise 1 → ClockWise	LSB
DP	Both	0 ... 359.9999	Deg.
LNR_A_X LNR_B_X LNR_C_X LNR_D_X	Only 4 pts	0 ... 359.9999	Deg.
LNR_A_Y LNR_B_Y LNR_C_Y LNR_D_Y	Only 4 pts	0 ... 100	%
LNR_S0 LNR_A_S LNR_B_S LNR_C_S LNR_D_S	Only 4 pts	-17 ... 0 ... 17	%/Deg.
LNR_Y0 LNR_Y1 ... LNR_Y16	Only 17 pts	-50 ... + 150	%
W	Only 17 pts	65.5 ... 360	Deg.
CLAMP_LOW	Both	0 ... 100	%
CLAMP_HIGH	Both	0 ... 100	%
ANGLEOFSSLOPECOLD (Only AxE)	Both	0..255	LSB
ANGLEOFSSLOPEHOT (Only AxE)	Both	0..255	LSB

13.2.1. Enable scaling Parameter (only for LNR type 4 pts)

This parameter enables to scale LNR_x_Y from -50% - 150% according to the following formula

$$\text{(Scaled Out)\%V}_{DD} = 2 \times \text{Out\%V}_{DD} - 50\%$$

13.2.2. CLOCKWISE Parameter

The CLOCKWISE parameter defines the magnet rotation direction.

- CCW is the defined by the 1-2-3-4 pin order direction for the Dual Mold Package.
- CW is defined by the reverse direction: 4-3-2-1 pin order direction for the Dual Mold Package.

Refer to the drawing in the sensitive spot positioning sections (Section 18.1.6).

13.2.3. Discontinuity Point (or Zero Degree Point)

The Discontinuity Point defines the 0 Deg. point on the circle. The discontinuity point places the origin at any location of the trigonometric circle. The DP is used as reference for all the angular measurements.

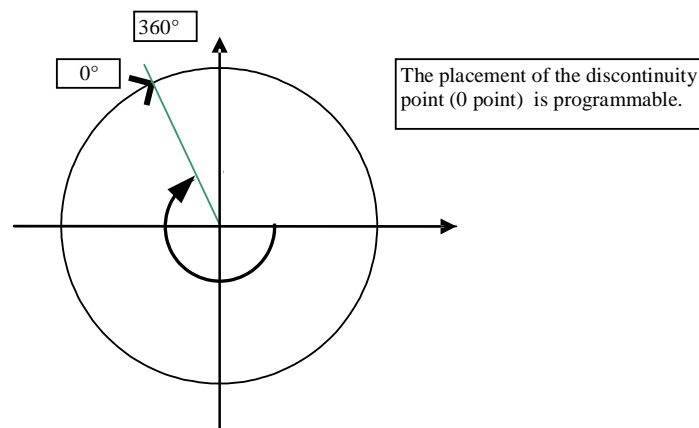

Figure 4 - Discontinuity Point Positioning

13.2.4. 4-Pts LNR Parameters

The LNR parameters, together with the clamping values, fully define the relation (the transfer function) between the digital angle and the output signal.

The shape of the MLX90364 transfer function from the digital angle value to the output voltage is described by the drawing below. Six segments can be programmed but the clamping levels are necessarily flat.

Two, three, or even six calibration points are then available, reducing the overall non-linearity of the IC by almost an order of magnitude each time. Three to six calibration points will be preferred by customers looking for excellent non-linearity figures. Two-point calibrations will be preferred by customers looking for a cheaper calibration set-up and shorter calibration time.

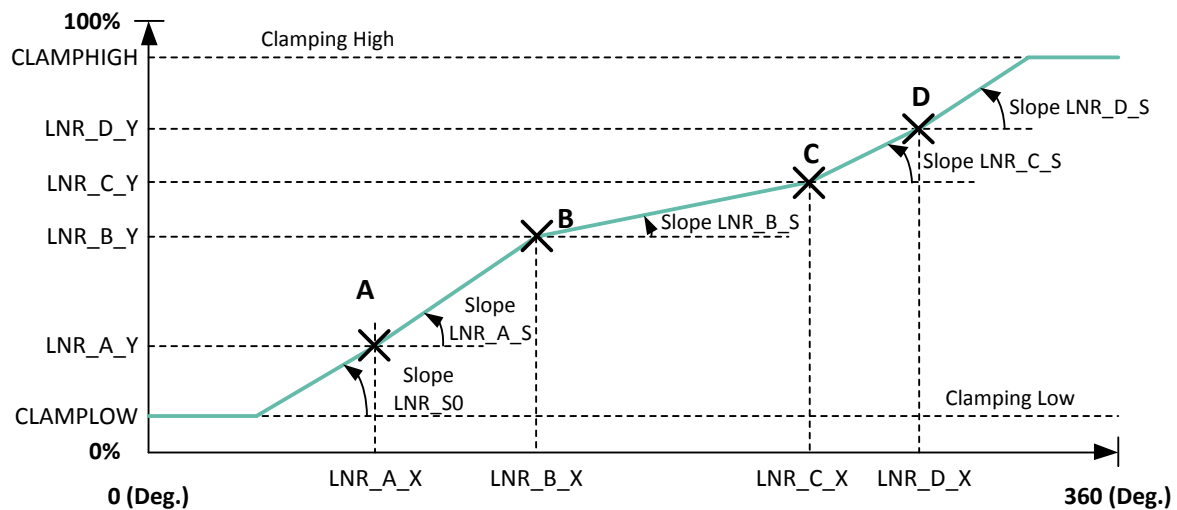

Figure 5 - 4-Pts LNR Parameters

13.2.5. 17-Pts LNR Parameters

The LNR parameters, together with the clamping values, fully define the relation (the transfer function) between the digital angle and the output signal.

The shape of the MLX90364 transfer function from the digital angle value to the output voltage is described by the drawing below. In the 17-Pts mode, the output transfer characteristic is Piece-Wise-Linear (PWL).

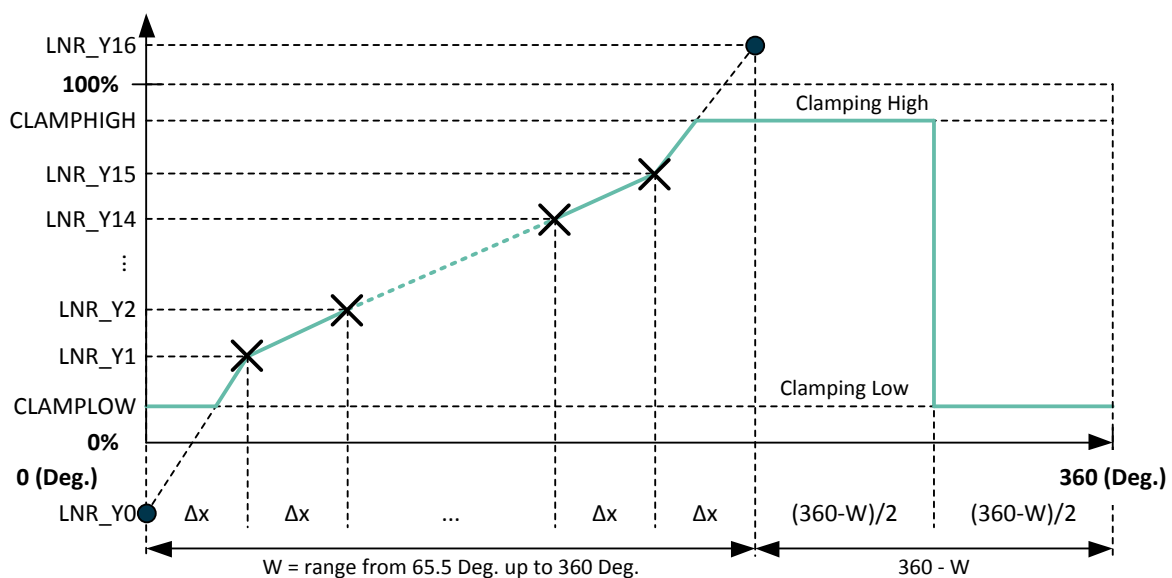

Figure 6 - Input range from 65.5 Deg. up to 360 Deg.

All the Y-coordinates can be programmed from -50% up to +150% to allow clamping in the middle of one segment (like on the Figure 6), but the output value is limited to CLAMPLOW and CLAMPHIGH values.

Between two consecutive points, the output characteristic is interpolated.

The parameter W determines the input range on which the 17 points (16 segments) are uniformly spread:

W	Range	Δx	W	Range	Δx
0 (0000b)	360.0 Deg.	22.5 Deg.	8	180.0 Deg.	11.3 Deg.
1	320.0 Deg.	20.0 Deg.	9	144.0 Deg.	9.0 Deg.
2	288.0 Deg.	18.0 Deg.	10	120.0 Deg.	7.5 Deg.
3	261.8 Deg.	16.4 Deg.	11	102.9 Deg.	6.4 Deg.
4	240.0 Deg.	15.0 Deg.	12	90.0 Deg.	5.6 Deg.
5	221.5 Deg.	13.8 Deg.	13	80.0 Deg.	5.0 Deg.
6	205.7 Deg.	12.9 Deg.	14	72.0 Deg.	4.5 Deg.
7	192.0 Deg.	12.0 Deg.	15 (1111b)	65.5 Deg.	4.1 Deg.

Outside of the selected range, the output will remain in clamping levels.

13.2.6. CLAMPING Parameters

The clamping levels are two independent values to limit the output voltage range. The CLAMPLOW parameter adjusts the minimum output voltage level. The CLAMPHIGH parameter sets the maximum output voltage level. Both parameters have 16 bits of adjustment and are available for both LNR modes. In analog mode, the resolution will be limited by the D/A converter (12 bits) to 0.024%VDD. In PWM mode, the resolution will be 0.024%DC.

13.2.7. Thermal Output Offset correction (AxE version only)

On the version AxE, the two parameters ANGLEOFSSLOPEHOT and ANGLEOFSSLOPECOLD, defined in the section 12, enable to add, to the output an offset depending on the measured temperature depicted in the Figure 7.

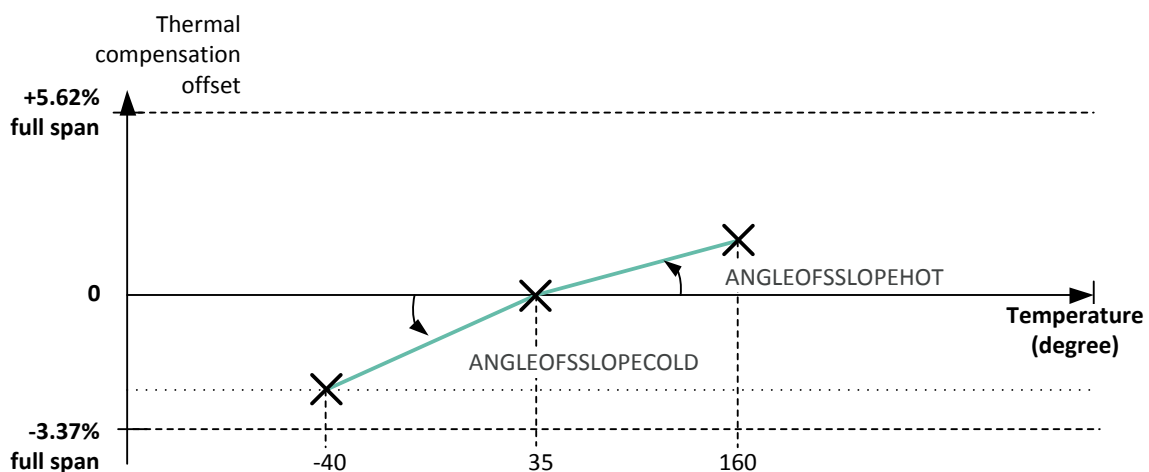

Figure 7 - Input range from -40 Deg.C up to 160 Deg.C

MLX90364 Triaxis® Position Sensor

Datasheet

The thermal offset is added before the clamping (see section 13.2.6). The span of this offset is +5.63/-3.37% of the full output scale. The added thermal offset varies with temperature see the equation below and the thermal coefficient is defined separately before (used coefficient ANGLEOFSSLOPECOLD) and after 35Deg.C (used coefficient ANGLEOFSSLOPEHOT).

If temperature is higher than 35 Deg.C then:

$$\text{output} \leq \text{output} - \Delta T * \text{ANGLEOFSSLOPEHOT}$$

If temperature is lower than 35 Deg.C then:

$$\text{output} \leq \text{output} - \Delta T * \text{ANGLEOFSSLOPECOLD}$$

Where output is the calculated output adjusted by the thermal correction offset $\Delta T * \text{ANGLEOFSSLOPECOLD}$. Where ΔT is the difference between current temperature and reference temperature 35Deg.C. The output correction capability at hot and room (extreme temperature and maximum value of ANGLEOFSSLOPEHOT and ANGLEOFSSLOPECOLD) are given in the table below.

Parameter	Min	Typ	Max	Unit
Output correction capability at 160DegC	5%	5.62%		of Full span
Output correction capability at -40DegC	3.09%	3.37%		of Full span

13.3. Identification

Parameter	Value
USERID1	0...65535
USERID2	0...65535
USERID3	0...65535

Identification number: 48 bits (3 words) freely useable by Customer for traceability purpose.

13.4. Lock

The MEMLOCK write protects all the EEPROM parameters set by the Melexis and user. Once the lock is enabled, it is not possible to change the EEPROM values anymore.

Note that the Memlock bits should be set by the solver function "MemLock" and is only applicable for the AxD and AxE versions.

13.5. Sensor Front-End

Parameter	Value
MAPXYZ	0...3
SMISM	0...32768
k	0...32768
SEL_k	0 or 1
GAINMIN	0...41
GAINMAX	0...41
GAINSATURATION	0...1

13.5.1. MAPXYZ

The MAPXYZ parameter defines which fields are used to calculate the angle. The different possibilities are described in the tables below.

This 2 bits value selects the first (B1) and second (B2) field components according the table below.

MAPXYZ	B1	B2	Angular
0 – 00b	X	Y	XY mode
1 – 01b	Zx	X	XZx mode
2 – 10b	Y	Zx	YZx mode

Note: MAPXYZ = 3 is not recommended.

13.5.2. SMISM, k and SEL_k Parameters

(i) SMISM

When the mapping (B1=X, B2=Y) is selected, SMISM defines the sensitivity mismatch factor that is applied on B1, B2; When another B1, B2 mapping is selected, this parameter is “don’t care”.

This parameter is trimmed at factory; Melexis strongly recommends TO NOT overwrite it for optimal performances.

(ii) k

When the mapping (B1=X, B2=Y) is **NOT** selected, k defines the sensitivity mismatch factor that is applied on B1 or B2 (according to parameter SEL_k – see below). When the mapping (B1=X, B2=Y) is selected, this parameter is “don’t care”.

MLX90364 Triaxis® Position Sensor

Datasheet

This parameter is trimmed at factory for mapping (B1=Z, B2=X). Melexis recommends to fine trim it when a smaller linearity error (Le) is required and a different mapping than (B1=X, B2=Y) is selected.

(iii) SEL_k

When the mapping (B1=X, B2=Y) is **NOT** selected, SEL_k defines the component on which the sensitivity mismatch factor k (see above): SEL_k = 0 means B1 → k · B1 and SEL_k = 1 means B2 → k · B2.

13.5.3. GAINMIN and GAINMAX Parameters

GAINMIN and GAINMAX define the thresholds on the gain code outside which the fault “GAIN out of Spec.” is set;

If GAINSATURATION is set, then the virtual gain code is saturated at GAINMIN and GAINMAX, and no Diagnostic fault is set since the saturations applies before the diagnostic check.

13.6. Filter

Parameter	Value
FILTER	0...2
FHYST	0...255

The MLX90364 includes 2 types of filters:

- Hysteresis Filter: programmable by the FHYST parameter
- Low Pass FIR Filters controlled with the FILTER parameter

13.6.1. Hysteresis Filter

The FHYST parameter is a hysteresis filter. The output value of the IC is not updated when the digital step is smaller than the programmed FHYST parameter value. The output value is modified when the increment is bigger than the hysteresis. The hysteresis filter reduces therefore the resolution to a level compatible with the internal noise of the IC. The hysteresis must be programmed to a value close to the noise level. (1 LSB = ± 0.012%)

13.6.2. FIR Filters

The MLX90364 features 2 FIR filter modes controlled with Filter = 1...2. Filter = 0 corresponds to no filtering. The transfer function is described below:

$$y_n = \frac{1}{\sum_{i=0}^j a_i} \sum_{i=0}^j a_i x_{n-i}$$

The filters characteristic is given in the following table:

Filter	0	1	2
J No	0	1	3
Type	Disable	Finite Impulse Response	
Coefficients ai	1	11	1111
Title	No filter	ExtraLight	Light
99% Response Time	1	2	4
Efficiency RMS (dB)	0	3.0	6.0

13.7. Programmable Diagnostic Settings

13.7.1. DIAG mode

The Diag mode defines the Output Stage mode in case of diagnostic.

DIAG mode [2:0]	Type	Descriptions	Comments
0	Disable	Output HiZ	Not recommended
5	Digital	open drain NMOS	
6	Digital	open drain PMOS	
7	Digital	Push-Pull	

13.7.2. DIAG Level

The Diag level determines the reporting level (diagnostic low, diagnostic high) during start-up (both analog and PWM mode), or during a fault reporting (Only in Analog mode).

In PWM mode, the fault reporting level shall in principle be 0 when the leading edge is a rising edge, (resp. 1 for a falling edge) in order to detect the first cycle after start-up. MLX recommends then DIAG Level = PWMPOL.

13.7.3. Field Strength Diagnostic

(i) FIELDTHRESHLOW

Defines the field strength limit under which a fault is reported. The run-time field strength estimation (FieldStrength) is compared to $2^8 * \text{FIELDTHRESHLOW}$.

The sensitivity of FIELDTHRESHLOW is typically 1mT/LSB. By default it is programmed to 10mT

(ii) FIELDTHRESHHIGH

Defines the field strength limit under which a fault is reported. See above for more details.

13.7.4. PWM Diagnostic

(i) DC_FAULT

Defines the duty-cycle that is outputted in case of diagnostic reporting.

(ii) WEAKMAGTHRESH

Defines the threshold on the field strength which determines the weak magnet condition; when WEAKMAGTHRESH = 0, there is no reporting of weak magnet condition.

(iii) DC_FTL

Defines the duty-cycle that is outputted in case of Field Too Low; the Field Too Low Diagnostic is stronger than the Weak Magnet Diagnostic, from 0% till 255% by steps of (100/256)%

(iv) DC_WEAK

Defines the duty-cycle that is outputted in case of Weak Magnet, from 0% till 255% by steps of (100/256)%

13.7.5. Diagnostic Features

It is recommended to enable the diagnostic features for safety critical applications.

Refer to Application_note_Diagnostic_Behavior_90365 for EE_CRC_Enable function description and for Diagnostic features which can be enabled by user.

13.8. EEPROM endurance

Although the EEPROM is used for Calibration Data Storage (similarly to an OTPROM), the MLX90364 embedded EEPROM is qualified to guarantee an endurance of minimum 1000 write cycles at 125°C for (engineering/calibration purpose).

MLX90364 Triaxis® Position Sensor

Datasheet

14. Self Diagnostic

The MLX90364 provides numerous self-diagnostic features. Those features increase the robustness of the IC functionality as it will prevent the IC to provide erroneous output signal in case of internal or external failure modes (“fail-safe”).

Diagnostic Item	Action	Effect on Outputs	Type	Monitoring Rate	Reporting Rate
Start-up phase Diagnostics					
RAM March C-10N Test	Fail-safe mode ** ** CPU reset after 120ms	Diagnostic low/ high Reporting (optional)	Digi HW	n/applicable (start-up only)	n/applicable (start-up only)
Watchdog BIST	Fail-safe mode ** ** CPU reset after 120ms	Diagnostic low/ high Reporting (optional)	Digi HW	n/applicable (start-up only)	n/applicable (start-up only)
FieldTooLow, W/ Programmable Threshold	Diagnostic (No Debouncing)	Diagnostic low/high Reporting (optional)	Environ &Analog	n/applicable (start-up only)	n/applicable (start-up only)
FieldTooHigh w/ Programmable Threshold	Diagnostic (No Debouncing)	Diagnostic low/high Reporting (optional)	Environ &Analog	n/applicable (start-up only)	n/applicable (start-up only)
WeakMagnet Diagnostic	Diagnostic (No Debouncing)	Diagnostic low/high Reporting (optional)	Environ	n/applicable (start-up only)	n/applicable (start-up only)
Under Voltage Monitoring <i>SUPPLYMONI = (MT3VB) OR (MT4VB)</i>	Start-up on Hold ** ** CPU reset after 120ms	Diagnostic low/high	Environ &Analog	n/applicable (start-up only)	n/applicable (start-up only)
Over Voltage Monitoring <i>MT7V</i>	PTC entry	Output in High-Impedance	Environ	n/applicable (start-up only)	n/applicable (start-up only)

MLX90364 Triaxis® Position Sensor

Datasheet

Diagnostic Item	Action	Effect on Outputs	Type	Monitoring Rate	Reporting Rate
Back-Ground Loop Diagnostics					
ROM 16bit checksum (continuous)	Fail-safe mode ** ** CPU reset after 120ms	Diagnostic low//high Reporting (optional)	Digi HW	$80 \cdot DTI_{DIG}$	$80 \cdot DTI_{DIG}$
RAM Test (continuous)	Fail-safe mode ** ** CPU reset after 120ms	Diagnostic low//high Reporting (optional)	Digi HW	$16 \cdot DTI_{DIG}$	$16 \cdot DTI_{DIG}$
EEPROM 8 bit CRC Check (continuous)	Fail-safe mode ** ** CPU reset after 120ms	Diagnostic low/high Reporting (optional)	Digi HW	$1 \cdot DTI_{DIG} (ADB)$ $5 \cdot DTI_{DIG} (AxD/AxE)$	$1 \cdot DTI_{DIG} (ADB)$ $5 \cdot DTI_{DIG} (AxD/AxE)$
Watchdog (continuous)	CPU reset	--	Digi HW	120ms	n/a
DSP Loop Diagnostics					
ADC Clipping ADCLIP	Debouncing (programmable)	Diagnostic low/high Reporting (optional)	Environ & Analog	$5/20 \cdot DTI_{ANA}$	$DTI_{ANA} \times \frac{Diag_Debounce_Thresh}{Diag_Debounce_Stepup}$
FieldTooLow, w/ Programmable Threshold	Debouncing (programmable)	Diagnostic low/high Reporting (optional)	Environ & Analog	$2/20 \cdot DTI_{ANA}$	$DTI_{ANA} \times \frac{Diag_Debounce_Thresh}{Diag_Debounce_Stepup}$
FieldTooHigh w/ Programmable Threshold	Debouncing (programmable)	Diagnostic low/high Reporting (optional)	Environ & Analog	$2/20 \cdot DTI_{ANA}$	$DTI_{ANA} \times \frac{Diag_Debounce_Thresh}{Diag_Debounce_Stepup}$
WeakMagnet Diagnostic	Debouncing (programmable)	Diagnostic low/high Reporting (optional)	Environ	$1/20 \cdot DTI_{ANA}$	$1 \cdot DTI_{ANA}$
Virtual Gain Code Out-of-spec GAINOOS	Debouncing (programmable)	Diagnostic low/high Reporting (optional)	Environ & Analog	$2/20 \cdot DTI_{ANA}$	$DTI_{ANA} \times \frac{Diag_Debounce_Thresh}{Diag_Debounce_Stepup}$
Virtual Gain Code Saturation [GAINMIN..GAIN MAX]	Saturation (optional)	Gain Saturated at GAINMIN-GAINMAX	Environ & Analog	n/applicable Not a diagnostic	n/applicable Not a diagnostic

MLX90364 Triaxis® Position Sensor

Datasheet

Diagnostic Item	Action	Effect on Outputs	Type	Monitoring Rate	Reporting Rate
ADC Monitor (Analog to Digital Converter) <i>ADCMONI</i>	Debouncing (programmable)	Diagnostic low/high Reporting (optional)	Analog HW	1 · DTI _{ANA}	$\frac{DTI_{ANA} \times \text{Diag_Debounce_Thresh}}{\text{Diag_Debounce_Stepup}}$
Under Voltage Monitoring <i>SUPPLYMONI = (MT3VB) OR (MT4VB)</i>	Supply Debouncing (programmable)	Diagnostic low/high Reporting (optional)	Environ & Analog	1 · DTI _{ANA}	$\frac{DTI_{ANA} \times \text{Diag_Debounce_Thresh}}{\text{Diag_Debounce_Stepup}}$
Over Voltage Monitoring <i>MT7V</i>	PTC entry after PTC Debouncing	Output in High- Impedance	Environ	8/20 · DTI _{ANA}	8/20 · DTI _{ANA}
Temperature Sensor Monitor <i>TEMPMONI</i>	Debouncing (programmable)	Diagnostic low/high Reporting (optional)	Analog	1 · DTI _{ANA}	$\frac{DTI_{ANA} \times \text{Diag_Debounce_Thresh}}{\text{Diag_Debounce_Stepup}}$
Temperature > 170degC (± 20) Temperature < -60degC (± 20)	Saturate value used for the compensations to -40degC and +150degC resp.	No effect	Environ & Analog	N/A Not a diagnostics	N/A Not a diagnostic

Hardware Diagnostics (continuously checked by dedicated Logic)

Read/Write Access out of physical memory	Fail-safe mode ** ** CPU reset after 120ms	Diagnostic Low/High	Digi HW	N/A Immediate Diagnostic	N/A Immediate Diagnostic
Write Access to protected area (IO and RAM Words)	Fail-safe mode ** ** CPU reset after 120ms	Diagnostic low/high	Digi HW	N/A	N/A
Unauthorized Mode Entry	Fail-safe mode ** ** CPU reset after 120ms	Diagnostic low/high	Digi HW	N/A	N/A
EEPROM Error Correcting Code (Hamming correction)	(Transparent) Error Correction	no effect	Digi HW	N/A	N/A

MLX90364 Triaxis® Position Sensor

Datasheet

Diagnostic Item	Action	Effect on Outputs	Type	Monitoring Rate	Reporting Rate
Hardware Diagnostics (continuously checked by dedicated Analog circuits)					
Broken VSS	CPU Reset on recovery	Pull down load => Diagnostic High Pull up load => Diagnostic High	Environ	n/a immediate Diagnostic	n/a immediate Diagnostic
Broken VDD	CPU Reset on recovery	Pull down load => Diagnostic Low Pull up load => Diagnostic Low	Environ	n/a immediate Diagnostic	n/a immediate Diagnostic
Resistive Cable Test	Start-up on Hold	Diagnostic low/high	Environ	n/a immediate Diagnostic	n/a immediate Diagnostic.

Dimension	Min	Typ	Max	Unit
DTI _{ANA}	5.7	6.0	6.3	ms
DTI _{DIG}	3.9	7.2	10 ⁽²¹⁾	ms

Table 2: Timing Specification @13.16 MHz

²¹ Corresponds to 20 output refresh

16. Standard information regarding manufacturability of Melexis products with different soldering processes

Our products are classified and qualified regarding soldering technology, solderability and moisture sensitivity level according to standards in place in Semiconductor industry.

For further details about test method references and for compliance verification of selected soldering method for product integration, Melexis recommends reviewing on our web site the General Guidelines soldering recommendation (<http://www.melexis.com/en/quality-environment/soldering>).

For all soldering technologies deviating from the one mentioned in above document (regarding peak temperature, temperature gradient, temperature profile etc), additional classification and qualification tests have to be agreed upon with Melexis.

For package technology embedding trim and form post-delivery capability, Melexis recommends consulting the dedicated trim&forming recommendation application note: lead trimming and forming recommendations (<http://www.melexis.com/en/documents/documentation/application-notes/lead-trimming-and-forming-recommendations>).

Melexis is contributing to global environmental conservation by promoting lead free solutions. For more information on qualifications of RoHS compliant products (RoHS = European directive on the Restriction Of the use of certain Hazardous Substances) please visit the quality page on our website: <http://www.melexis.com/en/quality-environment>.

17. ESD Precautions

Electronic semiconductor products are sensitive to Electro Static Discharge (ESD).

Always observe Electro Static Discharge control procedures whenever handling semiconductor products.

18. Package Information

18.1. DMP-4 Package

18.1.1. DMP-4 - Package Outline Dimensions (POD) – Straight Leads

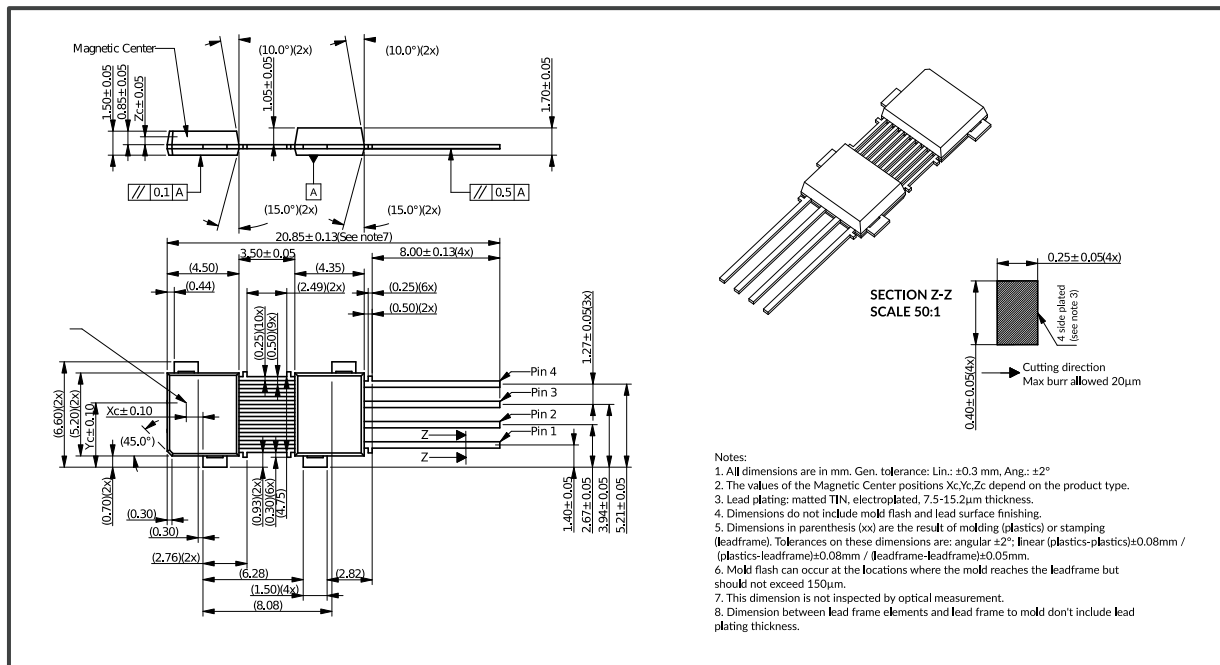

Figure 10 – DMP-4 information for straight leads MLX90364LVS-xxx-xx0

18.1.2. DMP-4 - Package Outline Dimensions (POD) – STD1 2.54

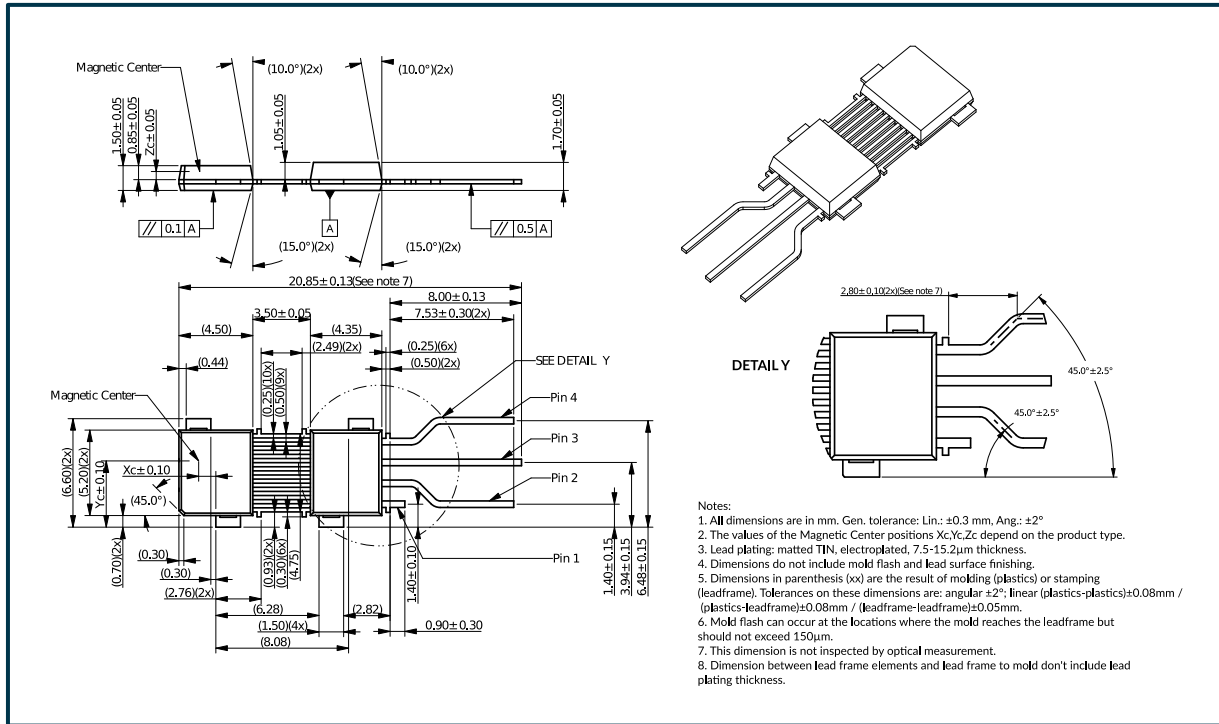

Figure 11 – DMP-4 Information for STD1 2.54 MLX90364LVS-xxx-xx1

18.1.3. DMP-4 - Package Outline Dimensions (POD) – STD2 2.54

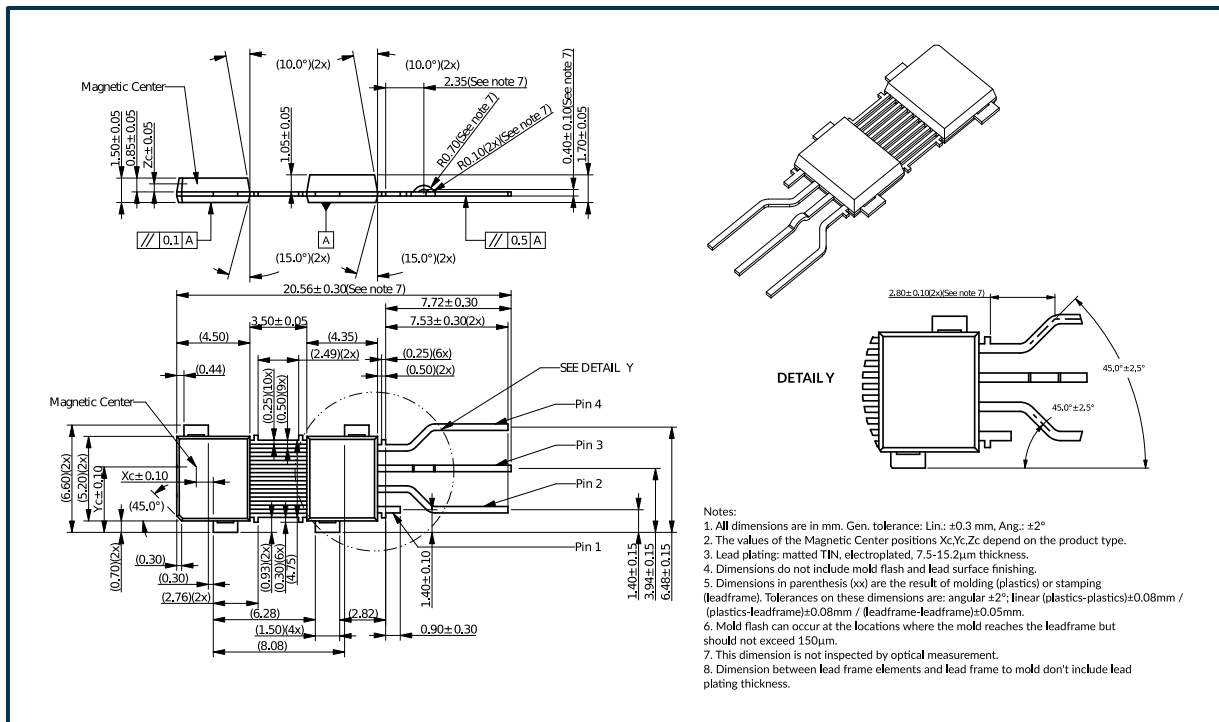

Figure 12 – DMP-4 information for STD2 2.54 MLX90364LVS-xxx-xx3

18.1.4. DMP-4 - Package Outline Dimensions (POD) – STD4 2.54

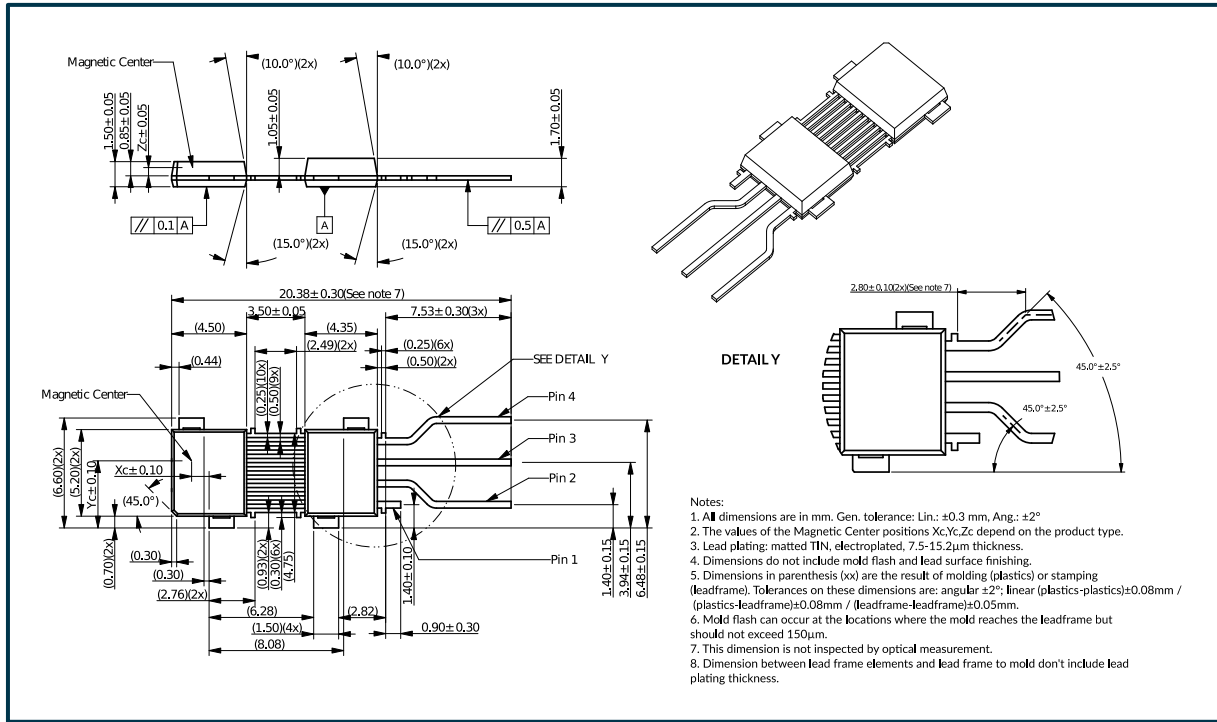

Figure 13 – DMP-4 information for STD4 2.54 MLX90364LVS-xxx-xx8

18.1.5. DMP-4 - Marking

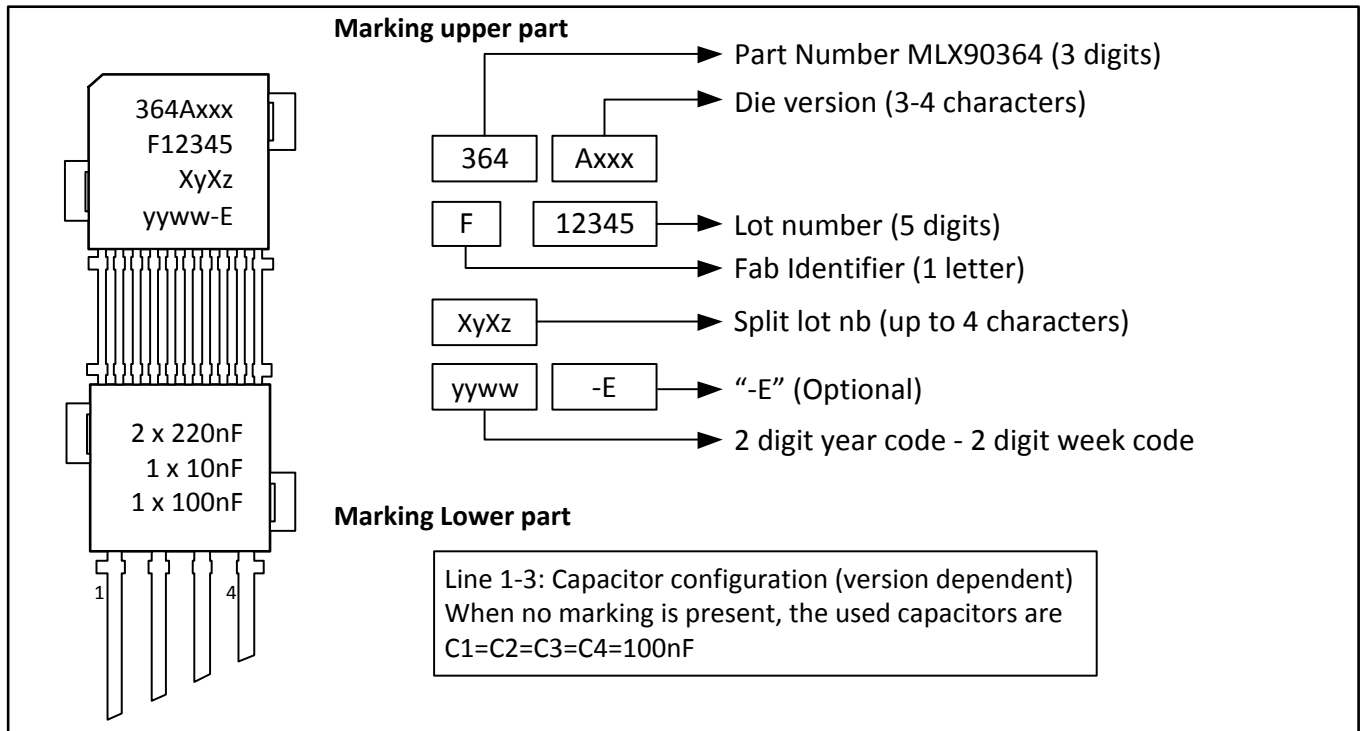
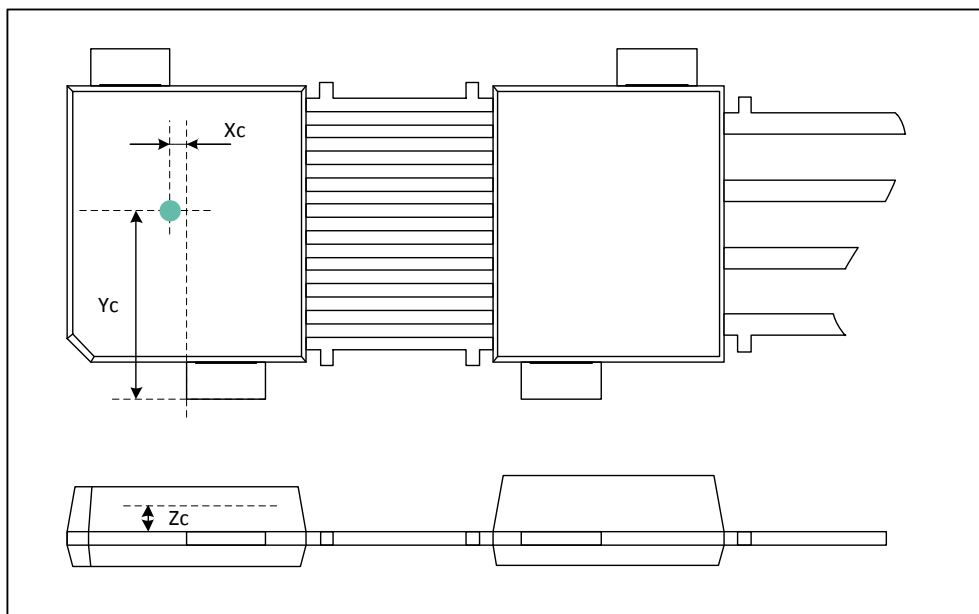

Figure 14 – DMP-4 marking convention

MLX90364 Triaxis® Position Sensor

Datasheet

18.1.6. DMP-4 - Sensitive Spot Positioning*Figure 15 – DMP-4 sensitive spot*

Magnetic center position	Position in mm
Xc	0.23
Yc	3.67
Zc	0.495

18.1.7. DMP-4 - Angle detection

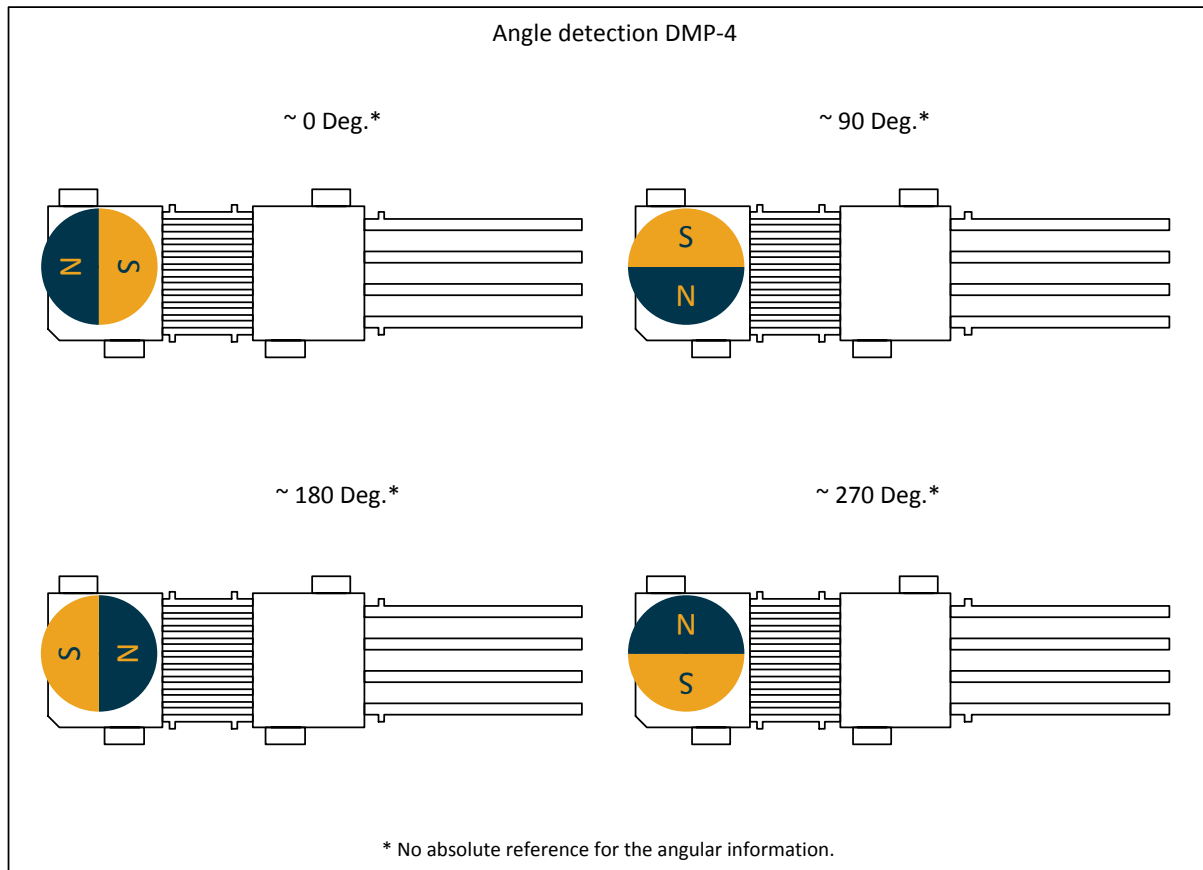

Figure 16 – DMP-4 angle detection

The MLX90364 is an absolute angular position sensor. Note however that the linearity error (See section 8) does not include the error linked to the absolute reference 0 Deg., which can be fixed in the application through the discontinuity point.

MLX90364 Triaxis® Position Sensor

Datasheet

19. Disclaimer

The information furnished by Melexis herein ("Information") is believed to be correct and accurate. Melexis disclaims (i) any and all liability in connection with or arising out of the furnishing, performance or use of the technical data or use of the product(s) as described herein ("Product") (ii) any and all liability, including without limitation, special, consequential or incidental damages, and (iii) any and all warranties, express, statutory, implied, or by description, including warranties of fitness for particular purpose, non-infringement and merchantability. No obligation or liability shall arise or flow out of Melexis' rendering of technical or other services.

The Information is provided "as is" and Melexis reserves the right to change the Information at any time and without notice. Therefore, before placing orders and/or prior to designing the Product into a system, users or any third party should obtain the latest version of the relevant information to verify that the information being relied upon is current.

Users or any third party must further determine the suitability of the Product for its application, including the level of reliability required and determine whether it is fit for a particular purpose.

The Information is proprietary and/or confidential information of Melexis and the use thereof or anything described by the Information does not grant, explicitly or implicitly, to any party any patent rights, licenses, or any other intellectual property rights.

This document as well as the Product(s) may be subject to export control regulations. Please be aware that export might require a prior authorization from competent authorities.

The Product(s) are intended for use in normal commercial applications. Unless otherwise agreed upon in writing, the Product(s) are not designed, authorized or warranted to be suitable in applications requiring extended temperature range and/or unusual environmental requirements. High reliability applications, such as medical life-support or life-sustaining equipment are specifically not recommended by Melexis.

The Product(s) may not be used for the following applications subject to export control regulations: the development, production, processing, operation, maintenance, storage, recognition or proliferation of 1) chemical, biological or nuclear weapons, or for the development, production, maintenance or storage of missiles for such weapons; 2) civil firearms, including spare parts or ammunition for such arms; 3) defense related products, or other material for military use or for law enforcement; 4) any applications that, alone or in combination with other goods, substances or organisms could cause serious harm to persons or goods and that can be used as a means of violence in an armed conflict or any similar violent situation.

The Products sold by Melexis are subject to the terms and conditions as specified in the Terms of Sale, which can be found at <https://www.melexis.com/en/legal/terms-and-conditions>.

This document supersedes and replaces all prior information regarding the Product(s) and/or previous versions of this document.

Melexis NV © - No part of this document may be reproduced without the prior written consent of Melexis. (2018)

ISO/TS 16949 and ISO14001 Certified

20. Contact

For the latest version of this document, go to our website at www.melexis.com. For additional information, please contact our Direct Sales team and get help for your specific needs:

Europe, Africa	Telephone: +32 13 67 04 95 Email : sales_europe@melexis.com
Americas	Telephone: +1 603 223 2362 Email : sales_usa@melexis.com
Asia	Email : sales_asia@melexis.com

OUR CERTIFICATE

DiGi provide top-quality products and perfect service for customer worldwide through standardization, technological innovation and continuous improvement. DiGi through third-party certification, we stricly control the quality of products and services. Welcome your RFQ to

Email: Info@DiGi-Electronics.com



Tel: +00 852-30501935

RFQ Email: Info@DiGi-Electronics.com

DiGi is a global authorized distributor of electronic components.