

BBFCV-492+ Datasheet

www.digi-electronics.com



<https://www.DiGi-Electronics.com>

DiGi Electronics Part Number	BBFCV-492+-DG
Manufacturer	Mini-Circuits
Manufacturer Product Number	BBFCV-492+
Description	LTCC BALUN BANDPASS FILTER, 4650
Detailed Description	RF Balun 4.65GHz ~ 5.15GHz 2:1 8-SMD, No Lead

This model BBFCV-492+ is available at DiGi Electronics.

DiGi Electronics offers a global database of semiconductor and electronic component datasheets.

We welcome your inquiries regarding pricing, lead time, or other product-related questions.

 [Request a Quote](#)

 [Datasheet Search](#)



Tel: +00 852-30501935

RFQ Email: Info@DiGi-Electronics.com

DiGi is a global authorized distributor of electronic components.

Purchase and inquiry

Manufacturer Product Number:

BBFCV-492+

Series:

-

Frequency Range:

4.65GHz ~ 5.15GHz

Phase Difference:

12°

Return Loss (Min):

0.04dB

Mounting Type:

Surface Mount

Manufacturer:

Mini-Circuits

Product Status:

Active

Impedance - Unbalanced/Balanced:

2:1

Insertion Loss (Max):

3.5dB

Package / Case:

8-SMD, No Lead

Environmental & Export classification

RoHS Status:

ROHS3 Compliant

ECCN:

EAR99

Moisture Sensitivity Level (MSL):

1 (Unlimited)

HTSUS:

8548.00.0000

Ceramic Balance Filter

50Ω 4650 to 5150 MHz

Features

- Small size (0.126"x0.098"x0.039")
- Temperature stable
- Hermetically sealed
- LTCC construction

Applications

- 5G
- Cellular

BBFCV-492+



Generic photo used for illustration purposes only

CASE STYLE: JV1210C-4

+RoHS Compliant

The +Suffix identifies RoHS Compliance. See our web site for RoHS Compliance methodologies and qualifications

Available Tape and Reel at no extra cost

Reel Size	Devices/Reel
7"	20, 50, 100, 200, 500, 1000, 2000

Simplified Schematic

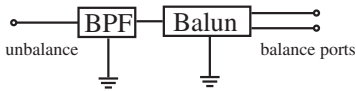

Electrical Specifications at 25°C

Parameter	Frequency (MHz)	Min.	Typ.	Max.	Unit
Impedance Ratio			2:1		
Insertion Loss	4650 - 5150	—	—	3.5	dB
Attenuation	50-1098	28	—	—	dB
	1098-4000	20	—	—	
	6696-8049	22	—	—	
	9645-12750	10	—	—	
Amplitude Unbalance	4650-5150	—	—	1.3	dB
Phase Unbalance	4650-5150	—	—	12	degree
Input VSWR	4650-5150	—	1.67	—	

Maximum Ratings

Operating Temperature	-55°C to +105°C
Storage Temperature ¹	-55°C to +105°C
RF Power Input ²	1W @25°C

1. Refer to product storage temperature after installation
Suggestion for T&R unused product storage condition: +5 ~ +35 °C, Humidity 45~75%RH, 12 month Max
2. Derate linearly to 0.5W at 85°C

Top View

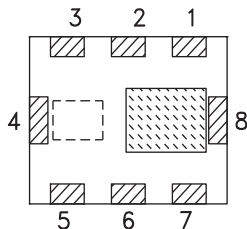

Pad Connections

Unbalanced Port	7
Balanced Port	3, 5
GND	2, 4, 8
GND or DC Feed	6
NC	1

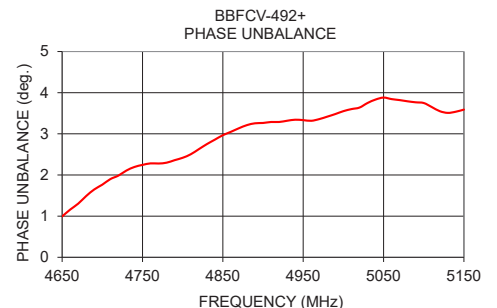
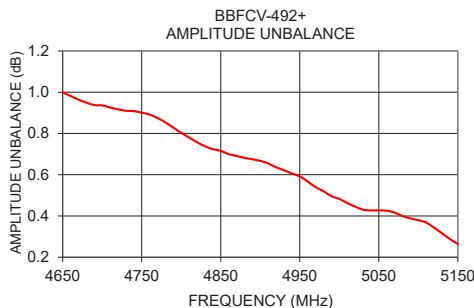
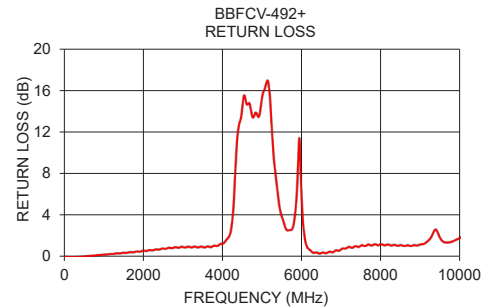
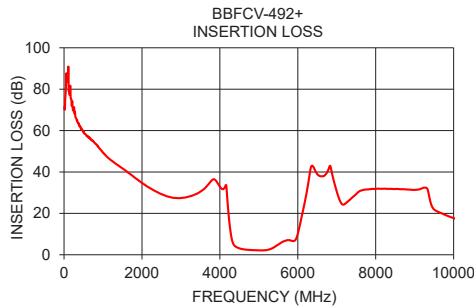

Balance Filter

BBFCV-492+

Typical Performance Data

Frequency (MHz)	Insertion Loss (dB)	Return Loss (dB)	Amplitude Unbalance (dB)	Phase Unbalance (Deg.)
10	71.41	0.06	1.38	100.60
50	81.78	0.04	2.23	151.82
100	83.48	0.04	8.13	134.82
500	59.00	0.08	9.62	168.96
1000	49.41	0.26	10.86	120.62
2000	34.69	0.62	1.97	57.65
3000	27.42	1.00	3.11	6.88
3500	30.50	1.00	1.03	40.22
4000	32.88	1.31	3.27	90.58
4650	2.52	14.66	1.00	1.33
5150	2.17	16.82	0.26	3.55
6000	10.14	5.42	0.91	0.65
7000	30.56	0.79	4.17	74.13
8000	31.83	1.25	1.36	63.10
9000	31.36	1.24	4.95	80.75
10000	17.71	1.88	3.06	167.42

Outline Drawing

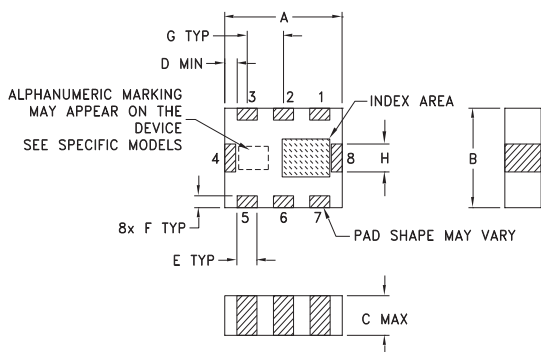

Suggested Layout, Tolerance to be within .002

Demo Board MCL P/N: TB-1053+ Suggested PCB Layout (PL-632)

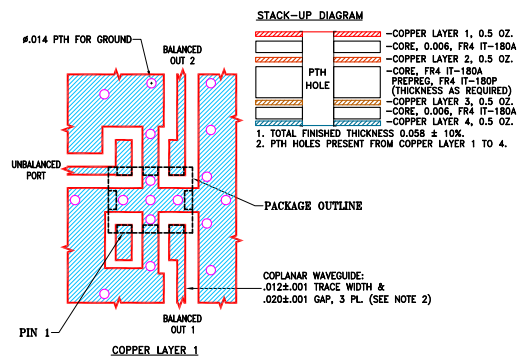

- NOTES:
- PCB IS MULTILAYER PCB, SEE STACK-UP DIAGRAM.
 - TRACE WIDTH & GAP PARAMETERS ARE SHOWN FOR FR4 IT-180A WITH DIELECTRIC THICKNESS .006"±.0007"; COPPER: 1/2 OZ. FOR OTHER MATERIALS TRACE WIDTH AND GAP MAY NEED TO BE MODIFIED.
 - LAYERS 2,3,4 OF THE PCB ARE CONTINUOUS GROUND PLANE.
- DENOTES COPPER LAND PATTERN FREE OF SOLDER MASK

Outline Dimensions (inch/mm)

A	B	C	D	E	F	G
.126	.098	.039	.004	.022	.012	.039
3.2	2.5	1.0	0.1	0.56	0.3	1.0
H	J	K	L	M	wt	
.028	.031	.024	.130	0.15	grams	
0.7	0.8	0.6	3.30	3.81	0.030	

Additional Notes

- Performance and quality attributes and conditions not expressly stated in this specification document are intended to be excluded and do not form a part of this specification document.
- Electrical specifications and performance data contained in this specification document are based on Mini-Circuit's applicable established test performance criteria and measurement instructions.
- The parts covered by this specification document are subject to Mini-Circuits standard limited warranty and terms and conditions (collectively, "Standard Terms"); Purchasers of this part are entitled to the rights and benefits contained therein. For a full statement of the Standard Terms and the exclusive rights and remedies thereunder, please visit Mini-Circuits' website at www.minicircuits.com/MCLStore/terms.jsp



OUR CERTIFICATE

DiGi provide top-quality products and perfect service for customer worldwide through standardization, technological innovation and continuous improvement. DiGi through third-party certification, we stricly control the quality of products and services. Welcome your RFQ to

Email: Info@DiGi-Electronics.com



Tel: +00 852-30501935

RFQ Email: Info@DiGi-Electronics.com

DiGi is a global authorized distributor of electronic components.