

MP2316GD-P Datasheet

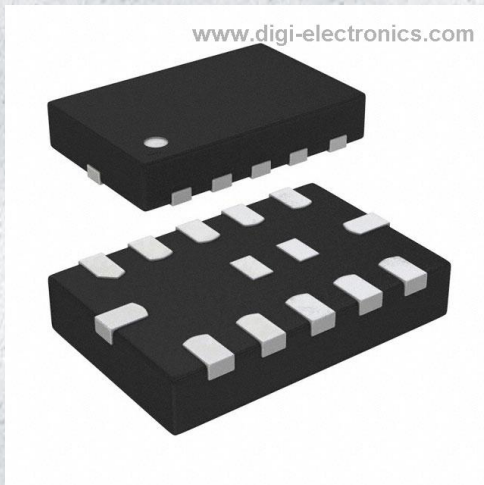

<https://www.DiGi-Electronics.com>

| | |
|------------------------------|--|
| DiGi Electronics Part Number | MP2316GD-P-DG |
| Manufacturer | Monolithic Power Systems Inc. |
| Manufacturer Product Number | MP2316GD-P |
| Description | IC REG BUCK ADJ 3A 14QFN |
| Detailed Description | Buck Switching Regulator IC Positive Adjustable 0.6 V 1 Output 3A 14-VFQFN |

This model MP2316GD-P is available at DiGi Electronics.

DiGi Electronics offers a global database of semiconductor and electronic component datasheets.

We welcome your inquiries regarding pricing, lead time, or other product-related questions.

 [Request a Quote](#)

 [Datasheet Search](#)



Tel: +00 852-30501935

RFQ Email: Info@DiGi-Electronics.com

DiGi is a global authorized distributor of electronic components.

Purchase and inquiry

Manufacturer Product Number:

MP2316GD-P

Series:

-

Function:

Step-Down

Topology:

Buck

Number of Outputs:

1

Voltage - Input (Max):

19V

Voltage - Output (Max):

19V

Frequency - Switching:

-

Operating Temperature:

-40°C ~ 125°C (Tj)

Package / Case:

14-VFQFN

Base Product Number:

MP2316

Manufacturer:

Monolithic Power Systems Inc.

Product Status:

Active

Output Configuration:

Positive

Output Type:

Adjustable

Voltage - Input (Min):

4V

Voltage - Output (Min/Fixed):

0.6V

Current - Output:

3A

Synchronous Rectifier:

Yes

Mounting Type:

Surface Mount

Supplier Device Package:

14-QFN (2x3)

Environmental & Export classification

RoHS Status:

ROHS3 Compliant

REACH Status:

REACH Unaffected

HTSUS:

8542.39.0001

Moisture Sensitivity Level (MSL):

1 (Unlimited)

ECCN:

EAR99



The Future of Analog IC Technology®

MP2316

19V, 3A, 40 μ A I_Q, High-Efficiency Constant On-Time (COT) Step-Down Converter in 2x3mm QFN Package

DESCRIPTION

The MP2316 is a fully-integrated, high efficiency, synchronous, step-down switch-mode converter, featuring only 40 μ A quiescent current. This very compact device achieves 3A continuous output current over a wide input supply range with excellent load and line regulation, and can operate with high efficiency over a wide output current load range. It's optimized for battery-operated applications and applications requiring high light load efficiency.

With Constant On-Time control, the MP2316 provides very fast transient response, easy loop design as well as very tight output regulation.

Full protection features include SCP, OCP, UVP, and thermal shutdown.

The MP2316 requires a minimal number of readily available standard external components with a space saving 2mmx3mm 14-pin QFN package.

FEATURES

- 4V to 19V Operating Input Range
- 3A Output Current
- 40 μ A Quiescent Current
- Output Adjustable from 0.6V
- 90m Ω /30m Ω High Side/Low Side R_{DS(ON)} for Internal Power MOSFETs
- Power Good Indicator
- Programmable Soft-Start Time
- Forced PWM or Auto PFM/PWM Mode Selectable
- Programmable Switching Frequency
- Thermal Shutdown
- Short Circuit Protection: Hiccup Mode
- Available in QFN14 (2mmx3mm) Package

APPLICATIONS

- Tablet PCs
- Solid State Drives
- Gaming
- Battery-operated Applications

All MPS parts are lead-free, halogen free, and adhere to the RoHS directive. For MPS green status, please visit MPS website under Quality Assurance.

"MPS" and "The Future of Analog IC Technology" are Registered Trademarks of Monolithic Power Systems, Inc.

TYPICAL APPLICATION

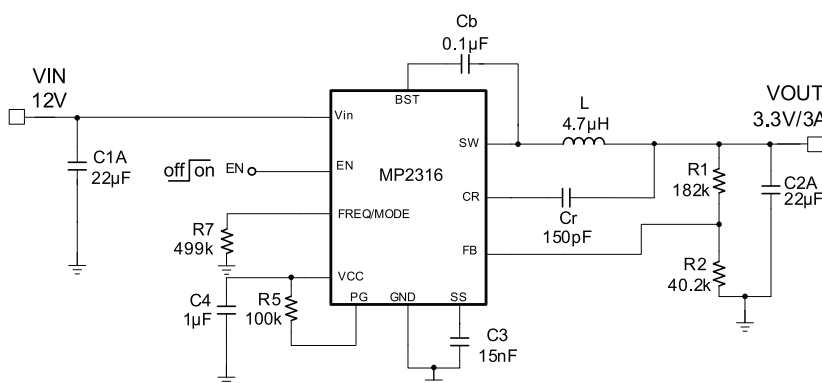

Efficiency vs. Output Current

Auto PFM/PWM, V_{OUT}=3.3V, L=4.7 μ H, DCR=19.5m Ω , F_{SW}=500kHz

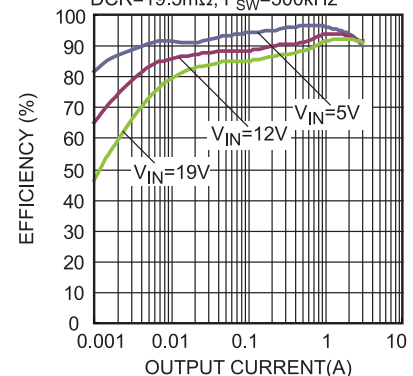



MP2316 – 19V, 3A LOW I_Q STEP DOWN CONVERTER

ORDERING INFORMATION

| Part Number* | Package | Top Marking |
|--------------|------------------|-------------|
| MP2316GD | QFN-14 (2mmx3mm) | See Below |

* For Tape & Reel, add suffix -Z (e.g. MP2316GD-Z);

TOP MARKING

AFJY
LLL

AFJ: product code of MP2316GD;

Y: year code;

LLL: lot number;

PACKAGE REFERENCE

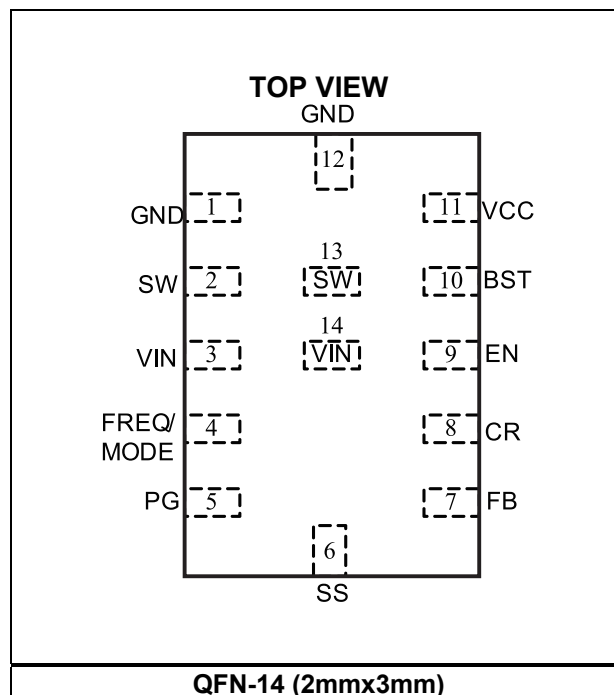

MP2316 – 19V, 3A LOW I_Q STEP DOWN CONVERTER
ABSOLUTE MAXIMUM RATINGS ⁽¹⁾

| | |
|--|--|
| V _{IN} | +21V |
| V _{FREQ/MODE} | +21V |
| V _{SW} .. | -0.3V (-5V<10ns) to V _{IN} +0.3V (23V<10ns) |
| V _{BST} | V _{SW} +6V |
| All Other Pins | -0.3V to +6V ⁽²⁾ |
| Continuous Power Dissipation ⁽³⁾ | |
| QFN-14 (2mmx3mm)..... | 1.8W |
| Junction Temperature..... | +150°C |
| Lead Temperature | +260°C |
| Storage Temperature..... | -65°C to +150°C |

Recommended Operating Conditions ⁽⁴⁾

| | |
|---------------------------------------|--|
| Supply Voltage V _{IN} | 4V to 19V |
| Output Voltage V _{OUT} | 0.6V to V _{IN} *D _{MAX} ⁽⁵⁾ |
| Operating Junction Temp. | -40°C to +125°C |

| | | |
|--|-----------------------|-----------------------|
| Thermal Resistance ⁽⁶⁾ | θ_{JA} | θ_{JC} |
| QFN-14 (2mmx3mm)..... | 70..... | 15...°C/W |

Notes:

- 1) Exceeding these ratings may damage the device
- 2) About the details of EN pin's ABS MAX rating, please refer to Enable control section.
- 3) The maximum allowable power dissipation is a function of the maximum junction temperature T_J (MAX), the junction-to-ambient thermal resistance θ_{JA}, and the ambient temperature T_A. The maximum allowable continuous power dissipation at any ambient temperature is calculated by P_D (MAX) = (T_J (MAX)-T_A)/θ_{JA}. Exceeding the maximum allowable power dissipation will cause excessive die temperature, and the regulator will go into thermal shutdown. Internal thermal shutdown circuitry protects the device from permanent damage.
- 4) The device is not guaranteed to function outside of its operating conditions.
- 5) About the D_{max}, See "Application When Input Voltage is Closed to Output Voltage" for more information.
- 6) Measured on JESD51-7, 4-layer PCB.



ELECTRICAL CHARACTERISTICS

V_{IN} = 12V, T_J = -40°C to +125°C ⁽⁷⁾, typical value is tested at T_J = +25°C, unless otherwise noted.

| Parameters | Symbol | Condition | Min | Typ | Max | Units |
|--|-----------------------|--|-----|------|-----|-----------------|
| Supply current (shutdown) | I _{IN} | V _{EN} = 0V | | 0.1 | 1 | μA |
| Supply current (quiescent) | I _Q | V _{EN} = 5V, T _J = 25°C, V _{FB} = 0.9V | | 40 | 55 | μA |
| VIN under-voltage lockout threshold rising | INUV _{Vth} | | 3.5 | 3.7 | 3.9 | V |
| VIN under-voltage lockout threshold hysteresis | INUV _{HYS} | | | 200 | | mV |
| HS switch-on resistance | HS _{RDS-ON} | | | 90 | | mΩ |
| LS switch-on resistance | LS _{RDS-ON} | | | 30 | | mΩ |
| Switch leakage | SW _{LKG} | V _{EN} = 0V, V _{SW} = 0V or 12V | | 0 | 1 | μA |
| High Side FET Current limit ⁽⁸⁾ | I _{LIMIT_HS} | Duty=10% | 5 | | | A |
| Low Side FET Current limit | I _{LIMIT_LS} | Force PWM Mode, Sink Current | | 1.5 | | A |
| One-Shot on time ⁽⁸⁾ | T _{ON} | R _{FREQ} =180k from FREQ/MODE Pin to VIN | | 230 | | ns |
| Minimum on time ⁽⁸⁾ | T _{ON_min} | | | 90 | | ns |
| Minimum off time | T _{OFF_min} | | | 150 | | ns |
| Feedback voltage | V _{FB} | T _J = 25°C | 594 | 600 | 606 | mV |
| | | T _J = -40°C to +125°C | 591 | 600 | 609 | |
| Feedback current | I _{FB} | V _{FB} = 700mV | | 10 | 50 | nA |
| Soft start current | I _{SS} | | 4 | 8 | 11 | μA |
| EN Input High Voltage | V _{EN_H} | | 1.6 | | | V |
| EN Input Low Voltage | V _{EN_L} | | | | 0.4 | V |
| EN input current | I _{EN} | V _{EN} = 2V | | 2 | | μA |
| | | V _{EN} = 0V | | 0 | | |
| Power-good rising threshold | PG _{Vth-Hi} | | | 0.9 | | V _{FB} |
| Power-good falling threshold | PG _{Vth-Lo} | | | 0.85 | | V _{FB} |
| Power-good delay | PG _{Td} | | | 140 | | μs |
| Power-good sink current capability | V _{PG} | Sink 1mA | | | 0.4 | V |
| Power-good leakage current | I _{PG_LEAK} | V _{PG} = 3.3V | | | 50 | nA |
| Thermal shutdown ⁽⁸⁾ | T _{SD} | | | 150 | | °C |
| Thermal shutdown hysteresis ⁽⁸⁾ | T _{SD-HYS} | | | 20 | | °C |

Notes:

- 7) Not tested in production. Guaranteed by over-temperature correlation.
 8) Guaranteed by design and engineering sample characterization.



MP2316 – 19V, 3A LOW I_Q STEP DOWN CONVERTER

TYPICAL PERFORMANCE CHARACTERISTICS

V_{IN}=12V, V_{OUT}=1.2V, L=2.2μH, T_A=25°C, unless otherwise noted.

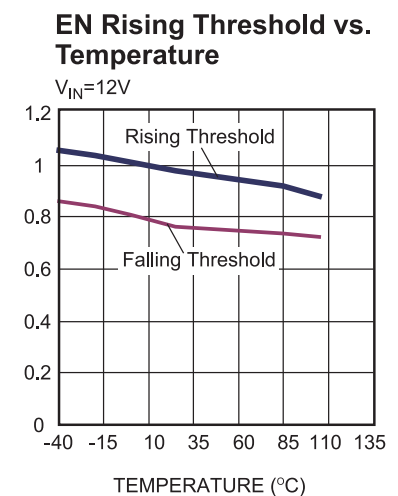
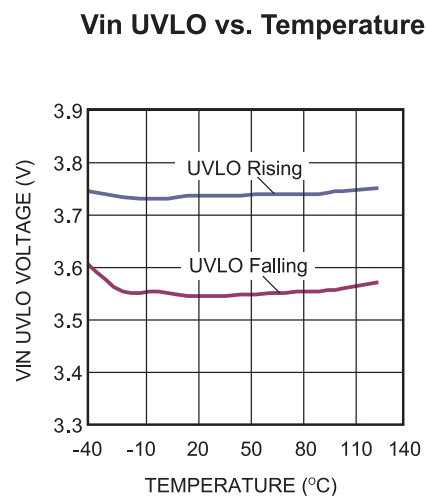
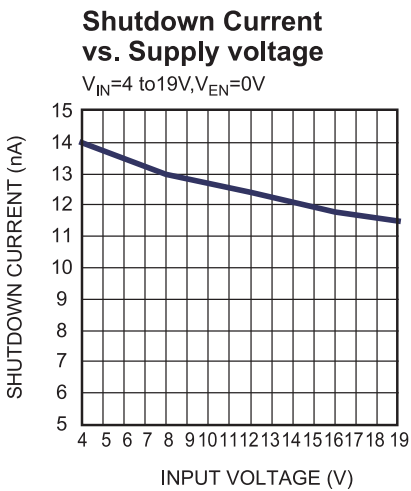
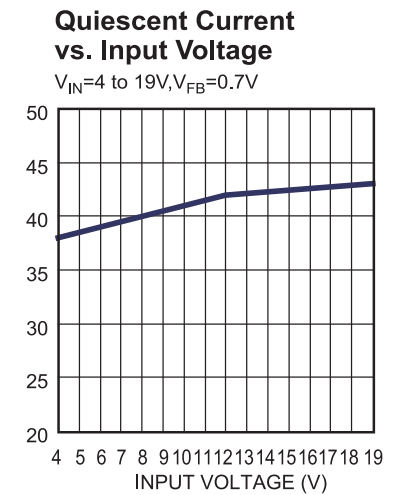
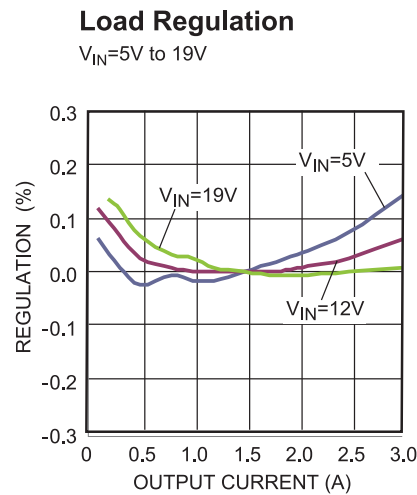
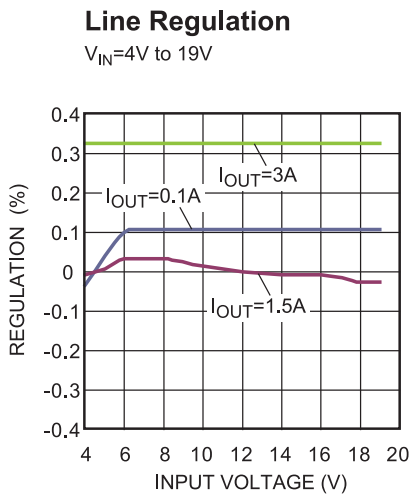
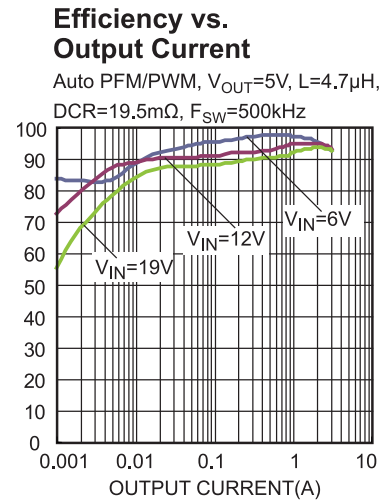
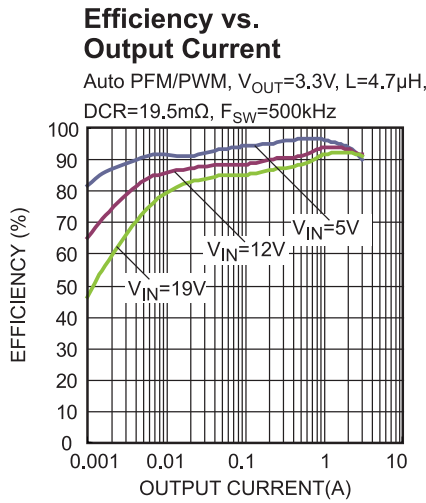
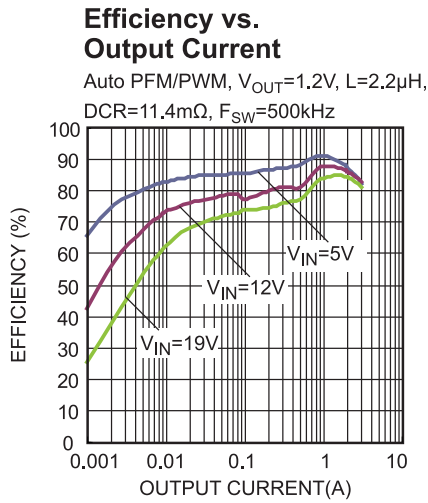



TYPICAL PERFORMANCE CHARACTERISTICS (continued)

V_{IN}=12V, V_{OUT}=1.2V, L=2.2μH, T_A=25°C, unless otherwise noted.

Max Frequency vs. Input Voltage

Consider the minimum on time and minimum off time only

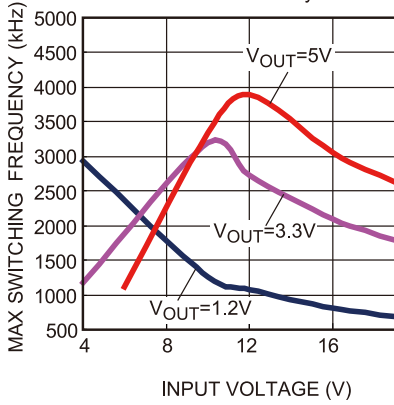

Case Temperature Rise vs. I_{OUT}

V_{OUT}=1.2V, I_{OUT}=1A to 3A, 4 Layers PCB, Size: 6.35cm X 6.35cm

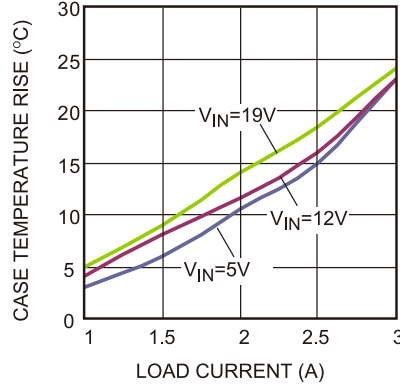

Case Temperature Rise vs. I_{OUT}

V_{OUT}=5V, I_{OUT}=1A to 3A, 4 Layers PCB, Size: 6.35cm X 6.35cm

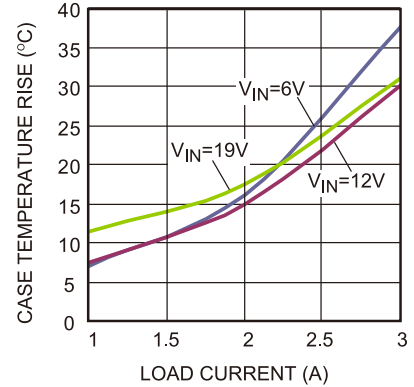



TYPICAL PERFORMANCE CHARACTERISTICS (continued)

V_{IN}=12V, V_{OUT}=1.2V, L=2.2μH, T_A=25°C, unless otherwise noted.

Input/Output Ripple

Auto PFM/PWM, I_{OUT}=0A

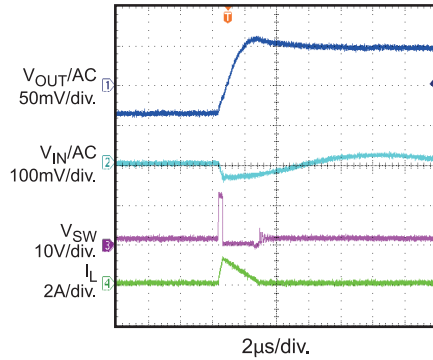

Input/Output Ripple

I_{OUT} = 3A

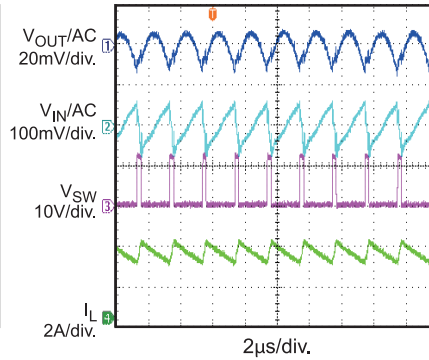

Input/Output Ripple

Forced PWM, I_{OUT}=0A

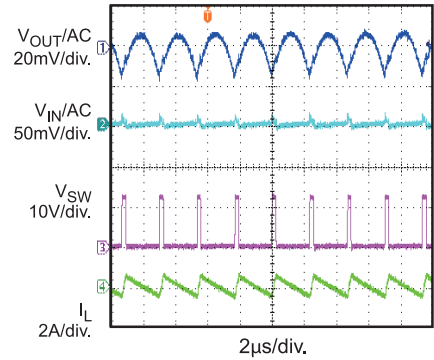

Startup through V_{IN}

Auto PFM/PWM, I_{OUT}=0A

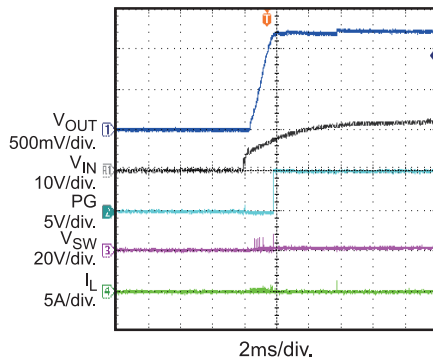

Startup through V_{IN}

I_{OUT} = 3A

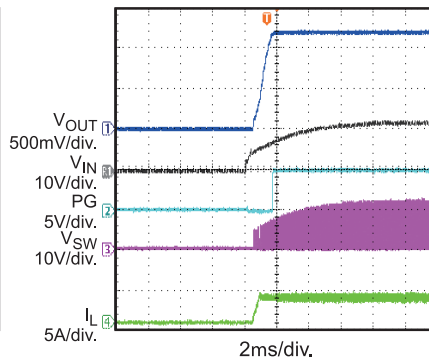

Startup through V_{IN}

Forced PWM, I_{OUT}=0A

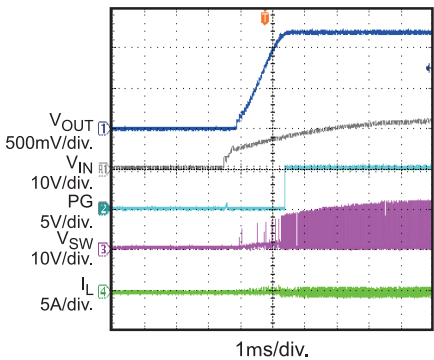

Shutdown through V_{IN}

Auto PFM/PWM, I_{OUT}=0A

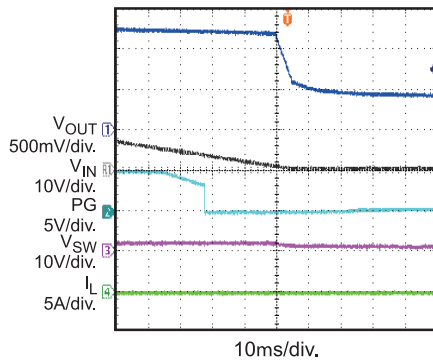

Shutdown through V_{IN}

I_{OUT} = 3A

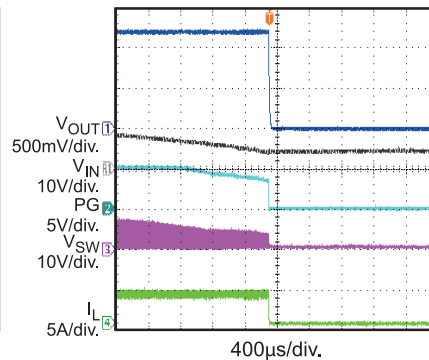

Shutdown through V_{IN}

Forced PWM, I_{OUT}=0A

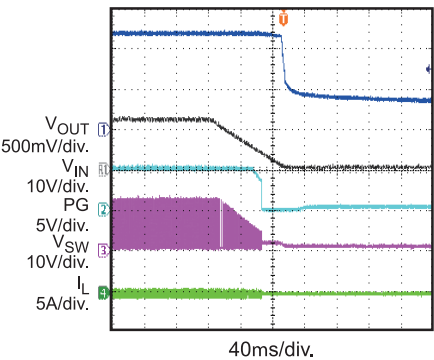



MP2316 – 19V, 3A LOW I_Q STEP DOWN CONVERTER

TYPICAL PERFORMANCE CHARACTERISTICS (continued)

V_{IN}=12V, V_{OUT}=1.2V, L=2.2μH, T_A=25°C, unless otherwise noted.

Startup through EN

Auto PFM/PWM, I_{OUT}=0A

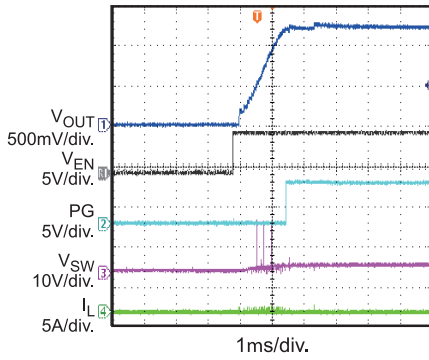

Startup through EN

I_{OUT} = 3A

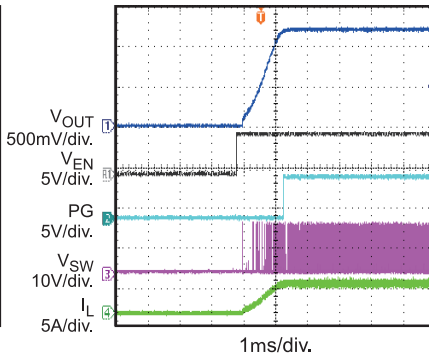

Startup through EN

Forced PWM, I_{OUT}=0A

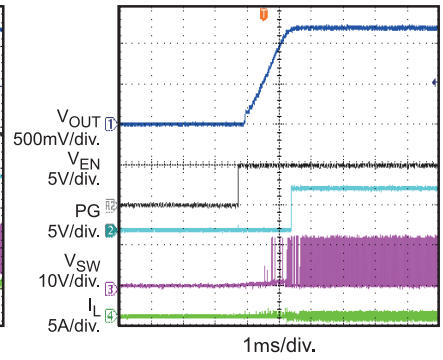

Shutdown through EN

Auto PFM/PWM, I_{OUT}=0A

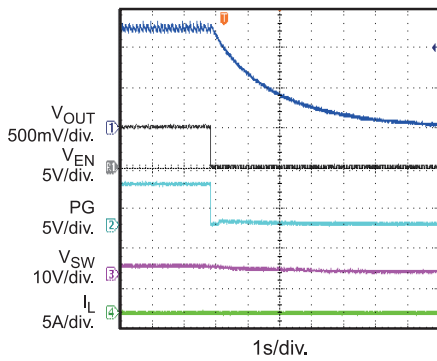

Shutdown through EN

I_{OUT} = 3A

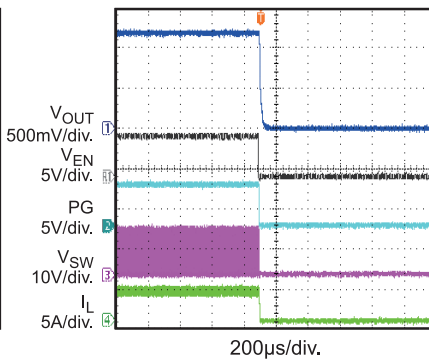

Shutdown through EN

Forced PWM, I_{OUT}=0A

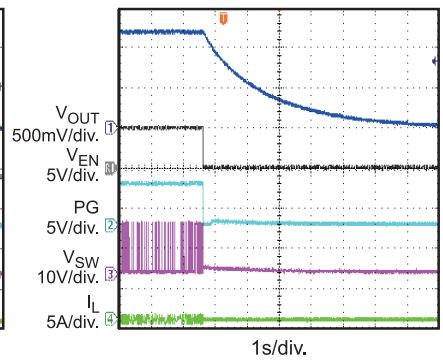

Short Circuit Entry

I_{OUT}=3A

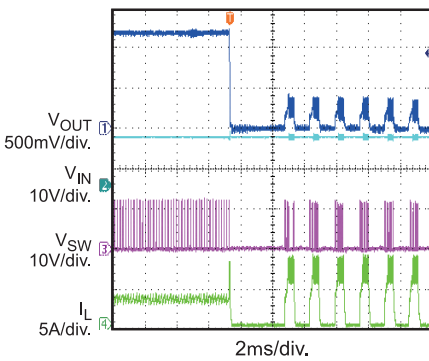

Short Circuit Recovery

I_{OUT} = 3A

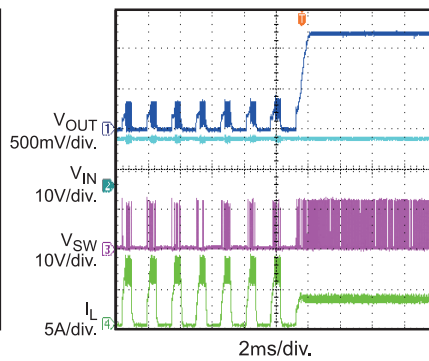

Short Circuit Steady

I_{OUT} = 3A

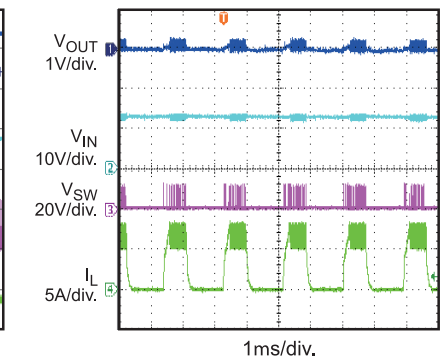

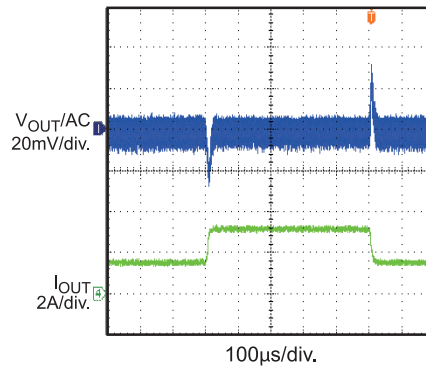
**TYPICAL PERFORMANCE CHARACTERISTICS** *(continued)***V_{IN}=12V, V_{OUT}=1.2V, L=2.2μH, T_A=25°C, unless otherwise noted.****Load Transient**I_{OUT}=1.5A to 3A, 250mA/μs



PIN FUNCTIONS

| Package Pin # | Name | Description |
|---------------|-----------|---|
| 1,12 | GND | System Ground. These pins are the reference ground for the regulated output voltage, and require special consideration during PCB layout. |
| 2, 13 | SW | Switch output. Connect using wide PCB traces. |
| 3, 14 | VIN | Supply Voltage. The MP2316 operates from a +4V to +19V input rail. C1 is needed to decouple the input rail. Use wide PCB traces and multiple vias to make the connection. |
| 4 | FREQ/MODE | Frequency set during CCM operation. Connect a resistor to VIN to set the switching frequency and part works at forced PWM mode. Connect a resistor to GND to set the switching frequency and part works at auto PFM/PWM mode. Don't float this pin. |
| 5 | PG | Power-Good Output. The output of this pin is an open drain that goes high if the output voltage is higher than 90% of the nominal voltage. There is a 40 μ s delay between when FB \geq 90% and when the PG pin goes high. Note: If PG is pulled up to an external voltage, PG will not de-assert (Logic low) if EN is low or if input power is off. It is recommended that PG is pulled up to VCC pin and in this case PG will de-assert (Logic low) when EN is Low or if input power is off. Refer to Applications section for additional details. |
| 6 | SS | Soft start. Connect a capacitor across SS and GND to set the soft-start time to avoid start up inrush current. |
| 7 | FB | Feedback. Sets the output voltage when connected to the tap of an external resistor divider that is connected between output and GND. |
| 8 | CR | Internal Ramp Adjust. Connect a capacitor from VOUT to this pin to adjust the internal ramp amplitude. This can be used to improve the transient performance. |
| 9 | EN | EN = 1 to enable the MP2316. For automatic start-up, connect EN pin to VIN with a pull-up resistor. |
| 10 | BST | Bootstrap requires a capacitor connected between SW and BST pins to form a floating supply across the high-side switch driver. |
| 11 | VCC | Internal Bias Supply. Internal 5V LDO output. Decouple with a 1 μ F ceramic capacitor as close to the pin as possible. |



FUNCTIONAL BLOCK DIAGRAM

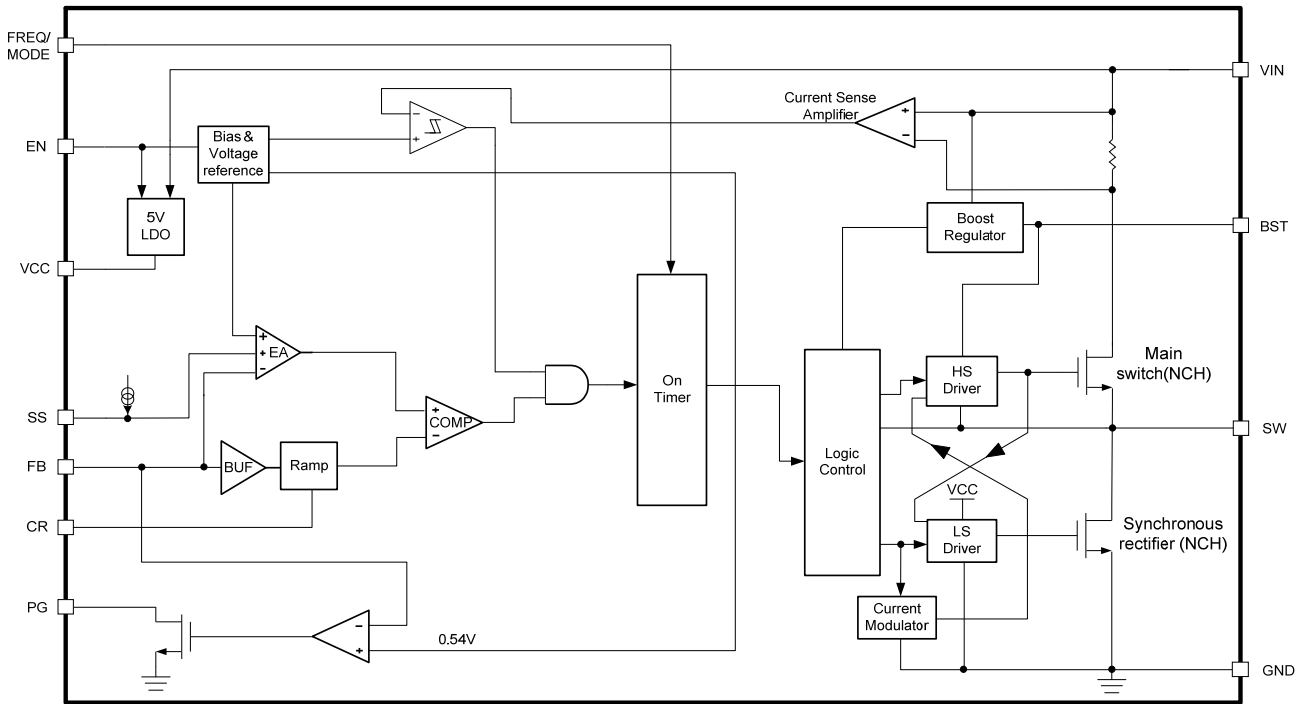

Figure 1—Functional Block Diagram



OPERATION

PWM Operation

The MP2316 is a fully-integrated, synchronous, rectified, step-down switch converter. The device uses constant-on-time (COT) control to provide fast transient response and easy loop compensation. Figure 2 shows the simplified ramp compensation block in MP2316, at the beginning of each cycle, the high-side MOSFET (HS-FET) turns ON whenever the ramp voltage (V_{Ramp}) is lower than the error amplifier output voltage (V_{EAO})—which indicates insufficient output voltage. The input voltage and the frequency-set resistor determine the high-side MOSFET turn-on timer (T_{ON}).

After the ON period elapses, the HS-FET enters the OFF state. By cycling HS-FET between the ON and OFF states, the converter regulates the output voltage. The integrated low-side MOSFET (LS-FET) turns on when the HS-FET is in its OFF state to minimize the conduction loss.

Shoot-through occurs when there is both HS-FET and LS-FET are turned on at the same time, causing a dead short between input and GND. Shoot-through dramatically reduces efficiency, and the MP2316 avoids this by internally generating a dead-time (DT) between HS-FET is off and LS-FET is on, LS-FET is off and HS-FET is on. The device enters either heavy-load operation or light-load operation depending on the output current.

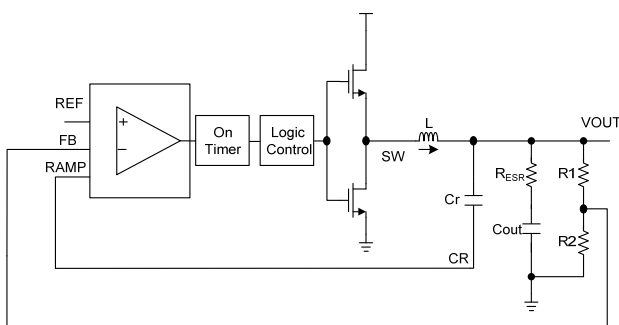

Figure 2—Simplified Ramp Compensation Block

MODE Selection

As shown in Figure 3, connecting a resistor (R_6) from FREQ/MODE pin to VIN can set the switching frequency and meanwhile, the part will

work at forced PWM mode. Connect a resistor (R_7) from FREQ/MODE pin to GND can set the switching frequency and meanwhile the part works at auto PFM/PWM mode.

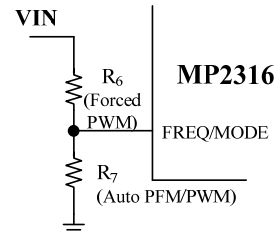

Figure 3—Mode Selection

Switching Frequency

MP2316 uses constant-on-time (COT) control and there is no dedicated oscillator in the IC. The input voltage is feed-forwarded to the on-time one-shot timer through the frequency resistor, the duty ratio is kept as V_{OUT}/V_{IN} , and the switching frequency is fairly constant over the input voltage range. The approximate typical switching frequency can be determined with the following equation:

$$F_{SW}(\text{KHz}) = \frac{10^6}{T_{on}(\text{ns}) \times \frac{V_{IN}(\text{V})}{V_{OUT}(\text{V})}} \quad (1)$$

T_{ON} will be slightly different at Forced PWM mode and Auto PFM/PWM mode. The approximate typical T_{on} formula is shown below:

Forced PWM mode:

$$T_{ON_PWM} = \frac{14.5 \times R_{FREQ}(\text{k}\Omega)}{V_{IN}(\text{V}) - 0.4} + T_{DELAY_PWM}(\text{ns}) \quad (2)$$

Auto PFM/PWM mode,

$$T_{ON_PFM} = \frac{13 \times R_{FREQ}(\text{k}\Omega)}{V_{IN}(\text{V}) - 0.4} + T_{DELAY_PFM}(\text{ns}) \quad (3)$$

Where T_{DELAY_PWM} and T_{DELAY_PFM} are the comparator delay, and the typical value equals approximately 15ns and 10ns respectively

When part enters CCM mode, the duty ratio will change slightly from light load to full load due to power loss. So the frequency will change a little from light load to full load even in CCM mode. Because of the minimum on time and minimum off time, switching frequency is limited. The



maximum frequency can be calculated by the following equations, choose the lower value of them as the maximum frequency:

$$F_{SW-max} (KHz) = \frac{10^6}{T_{on-min} (ns) \times \frac{V_{IN} (V)}{V_{OUT} (V)}} \quad (4)$$

$$F_{SW-max} (KHz) = \frac{(V_{IN} (V) - V_{OUT} (V)) \times 10^6}{T_{off-min} (ns) \times V_{IN} (V)} \quad (5)$$

Where Ton-min typical value is 90ns and Toff-min typical value is 150ns. For example, VIN=12V, Vout=1.2V, the maximum frequency we can set is about 1.1MHz. MP2316 is optimized to operate at high switching frequency with high efficiency. High switching frequency makes it possible to use small-sized LC filter components to save system PCB space.

Forced PWM Operation

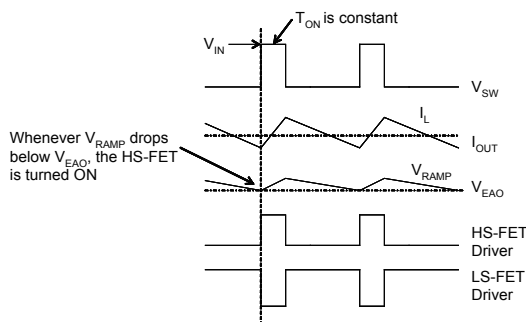

Figure 4—Force PWM Operation

When the MP2316 works in Forced PWM, the MP2316 enters continuous-conduction mode (CCM) where the HS-FET and LS-FET repeat the on/off operation, even if the inductor current goes to zero or negative value. The switching frequency (F_{SW}) is fairly constant. Figure 4 shows the timing diagram during this operation.

Light-Load Operation

When the MP2316 works in auto PFM/PWM mode and during light-load operation—the MP2316 automatically reduces the switching frequency to maintain high efficiency, and the inductor current drops near zero. When the inductor current reaches zero, the LS-FET driver goes into tri-state (high Z). Hence, the output capacitors discharge slowly to GND through LS-FET, R1, and R2. This operation greatly

improves device efficiency when the output current is low.

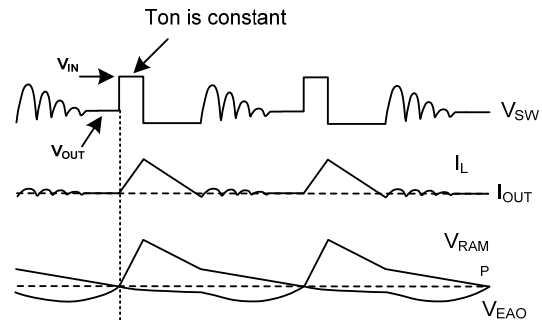

Figure 5—Light Load Operation

Light-load operation is also called skip mode because the HS-FET does not turn on as frequently as during heavy-load conditions. The frequency at which the HS-FET turns on is a function of the output current—as the output current increases, the time period that the current modulator regulates becomes shorter, and the HS-FET turns on more frequently. The switching frequency increases in turn. The output current reaches the critical level when the current modulator time is zero, and can be determined using the following equation:

$$I_{OUT} = \frac{(V_{IN} - V_{OUT}) \times V_{OUT}}{2 \times L \times F_{SW} \times V_{IN}} \quad (6)$$

The device reverts to PWM mode once the output current exceeds the critical level. After that, the switching frequency stays fairly constant over the output current range.

Application When Input Voltage is Close to Output Voltage.

MP2316 extends the on time when output voltage loses regulation when input voltage is close to output voltage. The switching frequency drops correspondingly in order to achieve larger duty cycle to keep output regulated. If the Vin is very close to Vout, Ton extension circuit will force MP2316 working in PWM mode with higher than expected frequency. Increasing Vin to certain level, part will exit this mode. Refer to Figure 6, MP2316 can work at auto PFM/PWM mode when Vin is above the curve. If auto PFM/PWM mode is required at input voltage below the curve, use Enable startup instead of input voltage startup.

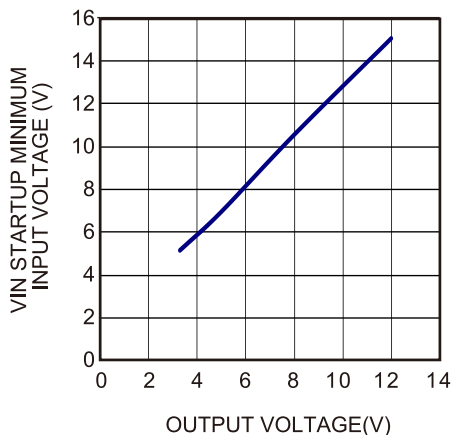

Figure 6—V_{IN} startup min V_{IN} vs. V_{OUT} to guarantee auto PFM/PWM mode work well

Floating Driver and Bootstrap Charging

An external bootstrap capacitor powers the floating power MOSFET driver. This floating driver has its own UVLO protection. This UVLO's rising threshold is 2.2V with a hysteresis of 150mV. The bootstrap capacitor voltage is regulated internally by V_{IN} through D1, M1, C_b, L1 and C2A (Figure 7). If (V_{IN}-V_{SW}) exceeds 5V, U1 will regulate M1 to maintain a 5V BST voltage across C_b.

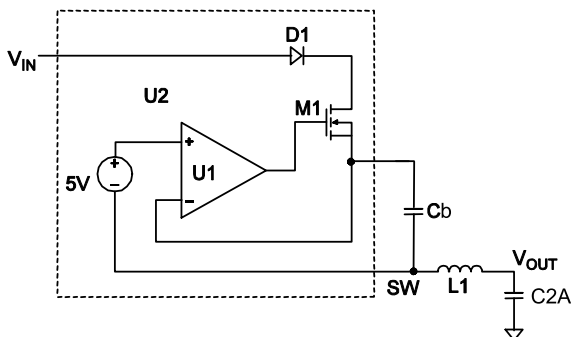

Figure 7—Bootstrap Charging Circuit

Ramp with small ESR Output Capacitor

When the output capacitors are ceramic ones, the ESR ripple is not high enough to stabilize the system, the external ramp compensation is needed.

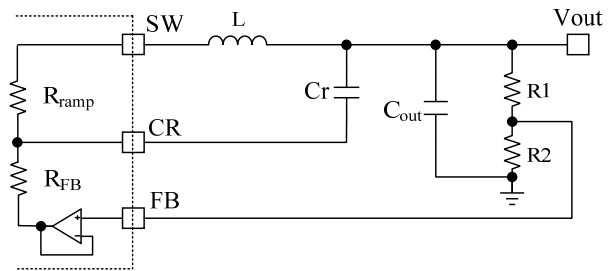

Figure 8—Simplified External Ramp Circuit in PWM Mode with Small ESR Cap

Figure 8 shows a simplified external ramp compensation for PWM mode. Choose the external ramp C_r to meet the following condition:

$$\frac{1}{2\pi \times F_{sw} \times C_r} < \frac{1}{5} R_{FB} \quad (7)$$

Where, R_{FB} is set to 90k internally. Then:

$$I_{Ramp} = I_{Cr} + I_{RFB} \approx I_{Cr} \quad (8)$$

And the V_{ramp} on the V_{CR} can be estimated as:

$$V_{ramp} = \frac{V_{in} - V_{out}}{R_{ramp} \times C_r} \times T_{on} \quad (9)$$

Where, R_{ramp} is set to 900k internally.

As can be seen from equation 9, if there is instability in PWM mode, we can reduce C_r. If C_r cannot be reduced further due to limitation from equation 7, then we can add an external resistor between SW and CR to reduce the equivalent R_{ramp}. Typically set V_{ramp} to about 20-40mV for a stable PWM operation.

Table 1 below is recommended C_r value for different output voltages. The recommended C_r value in Table 1 is based on 500kHz switching frequency, selected output inductor and 22μF output capacitors.

Table 1—Cr Selection for Common Output Voltages

| V _{OUT} (V) | L(μH) | Cr(pF) | |
|----------------------|-------|----------------------|---------------------|
| | | V _{IN} =12V | V _{IN} =5V |
| 1.0 | 2.2 | 82 | 82 |
| 1.2 | 2.2 | 100 | 100 |
| 1.5 | 3.3 | 120 | 82 |
| 1.8 | 3.3 | 120 | 56 |
| 2.5 | 3.3 | 150 | 56 |
| 3.3 | 4.7 | 150 | 56 |
| 5 | 4.7 | 100 | 56 ⁽⁸⁾ |

Notes:

9) When V_{OUT}=5V, V_{IN} should be higher than 6V.

Cr value may need change with different input voltage, output voltage, output inductor, output capacitor and frequency set. If the design spec is not the same as Table 1 spec, Cr value is needed to be adjusted accordingly. Take equation 9 as design guide.

In skip mode, the stability mainly determined by the ripple of V_{EAO}, a reasonable V_{ramp} chosen in PWM operation is generally ok for skip mode.

Soft Start

MP2316 employs a soft start (SS) mechanism to ensure smooth output ramping during power up. When the EN pin goes high, an internal current source (8μA) charges up the SS capacitor. The SS capacitor voltage takes over the REF voltage to the PWM comparator. The output voltage smoothly ramps up with the SS voltage. Once SS voltage rises above the V_{REF}, it continues to ramp up REF voltage takes over. At this point, the soft start finishes and it enters steady state operation.

The SS capacitor value can be determined as follows:

$$C_{ss}(\text{nF}) = \frac{T_{ss}(\text{ms}) \times I_{ss}(\text{uA})}{V_{REF}(\text{V})} \quad (10)$$

If the output capacitance is large value, it is not recommended to set the SS time too short. Otherwise, it's easy to hit the current limit during SS. A minimum value of 4.7nF is recommended if the output capacitance is larger than 330μF.

Pre-bias startup

The MP2316 has been designed for monotonic startup into pre-biased loads. If the output is pre-biased to a certain voltage during startup, the BST voltage will be refreshed and charged, the voltage on the soft-start capacitor will be charged too. If BST voltage exceeds its rising threshold voltage and Soft-start capacitor voltage exceeds the sensed output voltage at the FB pin, the part starts to work.

Power-Good (PG)

The PG pin is an open drain output. PG requires a pull up resistor (eg. 100k). PG pin is pulled to GND before SS is ready. After FB voltage reaches 90% of V_{REF}, the PG pin is pulled high after a 40μs delay. When the FB voltage drops below 85% of V_{REF}, the PG pin will be pulled low.

Note: If PG is pulled up to an external voltage, PG will not de-assert (Logic low) if EN is low or if V_{in} < 0.8V (typ). If PG is pulled up to the VCC pin, PG will de-assert (Logic low) if either EN is Low or if V_{in} < 0.8V (typ). If connecting two or more PG together, please refer to Application section.

Over-Current Protection (OCP) and Short-Circuit Protection (SCP)

MP2316 has cycle-by-cycle over-current limit control. During HS-FET ON state, the inductor current is monitored. When the sensed inductor current hits the peak current limit, the HS limit comparator (shown in Figure 1) is triggered, the device enters over-current protection mode immediately, turns off HS-FET and turns on LS-FET. Meanwhile, the output voltage drops until VFB is below the under-voltage (UV) threshold—typically 50% below the reference. Once UV is triggered, the MP2316 enters hiccup mode to periodically restart the part.

During over-current protection, the device tries to recover from over-current fault with hiccup mode, that means the chip will disable output power stage, discharge soft-start cap and then automatically try to soft-start again. If the over-current condition still holds after soft-start ends, the device repeats this operation cycle till over-current condition disappears and then output rises back to regulation level. The OCP is non-latch protection.



Enable Control

EN is a digital control pin that turns the regulator on and off. Drive EN high to turn on the regulator; drive it low to turn it off. An internal 1M Ω resistor from EN to GND allows EN to be floated to shut down the chip.

The EN pin is clamped internally using a 6.5V series-Zener-diode. Connecting the EN input pin through a pullup resistor to the voltage on the V_{IN} pin. The pull up resistance needs to be large enough to limit the EN pin current less than 100 μ A. For example, with 12V connected to V_{in}, $R_{PULLUP} \geq (12V - 6.5V) \div 100\mu A = 55k\Omega$.

Connecting the EN pin directly to a voltage source without any pullup resistor requires limit the amplitude of the voltage less than 6V to prevent damage to the Zener diode.

UVLO protection

MP2316 has under-voltage lock-out protection (UVLO). When the input voltage is higher than the UVLO rising threshold voltage, the MP2316 powers up. It shuts off when the input voltage is lower than the UVLO falling threshold voltage. This is non-latch protection.

Thermal Shutdown

The MP2316 employs thermal shutdown by internally monitoring the junction temperature of the IC. If the junction temperature exceeds the threshold value (typically 150 $^{\circ}$ C), the converter shuts off. This is non-latch protection. There is about 20 $^{\circ}$ C hysteresis. Once the junction temperature drops below 130 $^{\circ}$ C, it initiates start up.



APPLICATION INFORMATION

COMPONENT SELECTION

Setting the Output Voltage

The external resistor divider is used to set the output voltage. First, choose a value for R2. R2 should be chosen reasonably, a small R2 will lead to considerable quiescent current loss while too large R2 makes the FB noise sensitive. It is recommended to choose a value within for R2. Typically, set the current through R2 between will make a good balance between system stability and also the no load loss. Then R1 is determined as follow:

$$R1 = \frac{V_{OUT} - V_{REF}}{V_{REF}} \times R2 \quad (11)$$

Where the V_{REF} is 0.6V typically. The feedback circuit is shown as Figure 9.

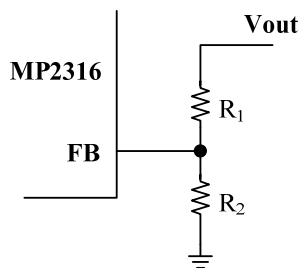

Figure 9—Feedback Network

Table 2 lists the recommended resistors value for common output voltages.

Table 2—Resistor Selection for Common Output Voltages⁽⁹⁾

| V _{OUT} (V) | R1(kΩ) | R2(kΩ) |
|----------------------|--------|--------|
| 1.0 | 27 | 40.2 |
| 1.2 | 40.2 | 40.2 |
| 1.5 | 60.4 | 40.2 |
| 1.8 | 80.6 | 40.2 |
| 2.5 | 127 | 40.2 |
| 3.3 | 182 | 40.2 |
| 5 | 294 | 40.2 |

Notes:

10) The feedback resistors in table 2 are optimized for 500kHz switching frequency. The detailed schematics are shown on the typical application circuit section.

Setting the Frequency

Refer to Mode selection section. Set the forced PWM mode switching frequency by connecting a resistor R6 from VIN to FREQ/MODE pin and leaving R7 NS. The R6 is determined as follows:

$$R6(k\Omega) = \frac{\left[\frac{V_o \times 10^6}{F_{SW} (kHz) \times V_{IN}} - T_{Delay_PWM} (ns) \right] \cdot (V_{IN} - 0.4)}{14.5} \quad (12)$$

Where T_{Delay_PWM} is about 15ns.

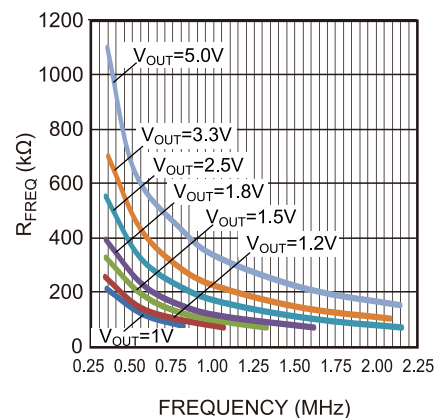

Figure 10—R6 vs. Forced PWM Mode Switching Frequency

Set the auto PFM/PWM mode switching frequency by connecting a resistor R7 from FREQ/MODE pin to ground and leaving R6 NS. The R7 is determined as follow:

$$R7(k\Omega) = \frac{\left[\frac{V_o \times 10^6}{F_{SW} (kHz) \times V_{IN}} - T_{Delay_PFM} (ns) \right] \cdot (V_{IN} - 0.4)}{13} \quad (13)$$

Where T_{Delay_PFM} is about 10ns.

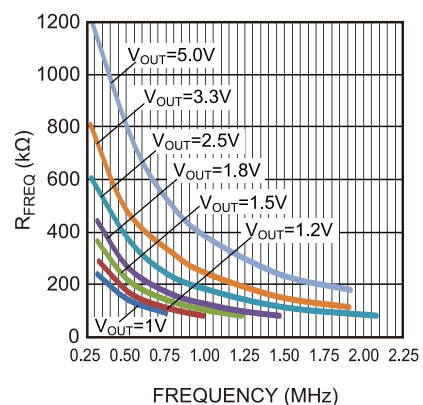

Figure 11—R7 vs. Auto PFM/PWM Mode Switching Frequency



Equation 12 and 13 are the typical switching frequency calculation formula. The actually frequency will change a little at different load currents and different input voltages as described before.

Selecting the Inductor

The inductor is necessary to supply constant current to the output load while being driven by the switched input voltage. A larger-value inductor will result in less ripple current that will result in lower output ripple voltage. However, a larger-value inductor will have a larger physical footprint, higher series resistance, and/or lower saturation current. A good rule for determining the inductance value is to design the peak-to-peak ripple current in the inductor to be in the range of 30% to 40% of the maximum output current, and that the peak inductor current is below the maximum switch current limit. The inductance value can be calculated by:

$$L = \frac{V_{OUT}}{F_{SW} \times \Delta I_L} \times \left(1 - \frac{V_{OUT}}{V_{IN}}\right) \quad (14)$$

Where ΔI_L is the peak-to-peak inductor ripple current.

The inductor should not saturate under the maximum inductor peak current, where the peak inductor current can be calculated by:

$$I_{LP} = I_{OUT} + \frac{V_{OUT}}{2F_{SW} \times L} \times \left(1 - \frac{V_{OUT}}{V_{IN}}\right) \quad (15)$$

Selecting the Input Capacitor

The input current to the step-down converter is discontinuous and therefore requires a capacitor to supply the AC current to the step-down converter while maintaining the DC input voltage. Ceramic capacitors are recommended for best performance and should be placed as close to the VIN pin as possible. Capacitors with X5R and X7R ceramic dielectrics are recommended because they are fairly stable with temperature fluctuations.

The capacitors must also have a ripple current rating greater than the maximum input ripple current of the converter. The input ripple current can be estimated as follows:

$$I_{CIN} = I_{OUT} \times \sqrt{\frac{V_{OUT}}{V_{IN}} \times \left(1 - \frac{V_{OUT}}{V_{IN}}\right)} \quad (16)$$

The worst-case condition occurs at $V_{IN} = 2V_{OUT}$, where:

$$I_{CIN} = \frac{I_{OUT}}{2} \quad (17)$$

For simplification, choose the input capacitor with an RMS current rating greater than half of the maximum load current.

The input capacitance value determines the input voltage ripple of the converter. If there is an input voltage ripple requirement in the system, choose the input capacitor that meets the specification.

The input voltage ripple can be estimated as follows:

$$\Delta V_{IN} = \frac{I_{OUT}}{F_{SW} \times C_{IN}} \times \frac{V_{OUT}}{V_{IN}} \times \left(1 - \frac{V_{OUT}}{V_{IN}}\right) \quad (18)$$

Under worst-case conditions where $V_{IN} = 2V_{OUT}$:

$$\Delta V_{IN} = \frac{1}{4} \times \frac{I_{OUT}}{F_{SW} \times C_{IN}} \quad (19)$$

Selecting the Output Capacitor

The output capacitor is required to maintain the DC output voltage. Ceramic or POSCAP capacitors are recommended. The output voltage ripple can be estimated as:

$$\Delta V_{OUT} = \frac{V_{OUT}}{F_{SW} \times L} \times \left(1 - \frac{V_{OUT}}{V_{IN}}\right) \times \left(R_{ESR} + \frac{1}{8 \times F_{SW} \times C_{OUT}}\right) \quad (20)$$

In the case of ceramic capacitors, the impedance at the switching frequency is dominated by the capacitance. The output voltage ripple is mainly caused by the capacitance. For simplification, the output voltage ripple can be estimated as:

$$\Delta V_{OUT} = \frac{V_{OUT}}{8 \times F_{SW}^2 \times L \times C_{OUT}} \times \left(1 - \frac{V_{OUT}}{V_{IN}}\right) \quad (21)$$

The output voltage ripple caused by ESR is very small. Therefore, an external ramp is needed to stabilize the system. The external ramp can be generated through the capacitor Cr.

In the case of POSCAP capacitors, the ESR dominates the impedance at the switching frequency. For simplification, the output ripple can be approximated as:



$$\Delta V_{OUT} = \frac{V_{OUT}}{F_{SW} \times L} \times \left(1 - \frac{V_{OUT}}{V_{IN}}\right) \times R_{ESR} \quad (22)$$

Besides considering the output ripple, chose larger output capacitor also can get better load transient response, but maximum output capacitor limitation should be also considered in design application. If the output capacitor value is too high, the output voltage can't reach the design value during the soft-start time, and then it will fail to regulate. The maximum output capacitor value C_{O_max} can be limited approximately by:

$$C_{O_MAX} = (I_{LIM_AVG} - I_{OUT}) \times T_{ss} / V_{OUT} \quad (23)$$

Where, I_{LIM_AVG} is the average start-up current during soft-start period. T_{ss} is the soft-start time.

PG Pull-Up

It is recommended that PG is pulled up to VCC for proper operation. If PG is pulled up to external voltage or if connecting two or more PG together, connect a diode from PG to EN as shown in Fig.12 and Fig.13. In this case PG will de-assert low when EN signal is low. But PG will not de-assert low when input power is off and EN signal is high condition.

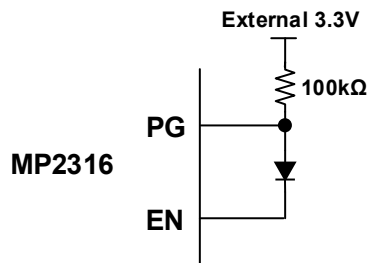

Figure 12: PG Pull up to external power supply with enable control signal --- Single PG Output

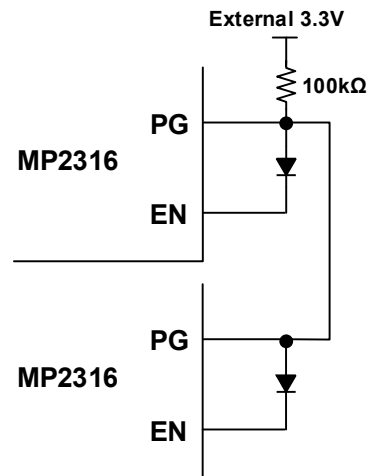

Figure 13: PG Pull up to external power supply with enable control signal --- PG parallel Output

External Bootstrap Diode

BST voltage may become insufficient at some particular conditions. In this case an external bootstrap diode can enhance the efficiency of the regulator and help to avoid BST voltage insufficient at light load PFM operation. The BST voltage insufficient is more likely to happen at given either of the following conditions:

- V_{IN} is low
- Duty cycle is large: $D = \frac{V_{OUT}}{V_{IN}} > 65\%$

In these cases, if BST voltage insufficient happens the output ripple voltage may become extremely large at light load condition or bad efficiency at heavy load condition, add an external BST diode from the VCC pin to BST pin, as shown in Figure 14.

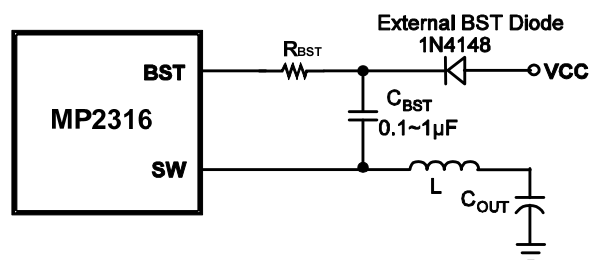

Figure 14: Optional External Bootstrap Diode
The recommended external BST diode is 1N4148.



PC Board Layout

Proper layout of the switching power supplies is very important, and sometimes critical for proper function. Poor layout design can result in poor line or load regulation and stability issues. Please follow these guidelines and take Figure 15 as reference:

- 1) The high current paths (GND, IN and SW) should be placed very close to the device with short, direct and wide traces.
- 2) The input capacitor needs to be as close as possible to the IN and GND pins.
- 3) The Mode/Frequency circuit should be placed closed to the part.
- 4) The external feedback resistors should be placed next to the FB pin.
- 5) Keep the switching node SW short and away from the feedback network.

In order to have better performances, it is better to use four layers boards. Figure 15 shows the top and bottom layers (Inner 1 and Inner 2 are all GND).

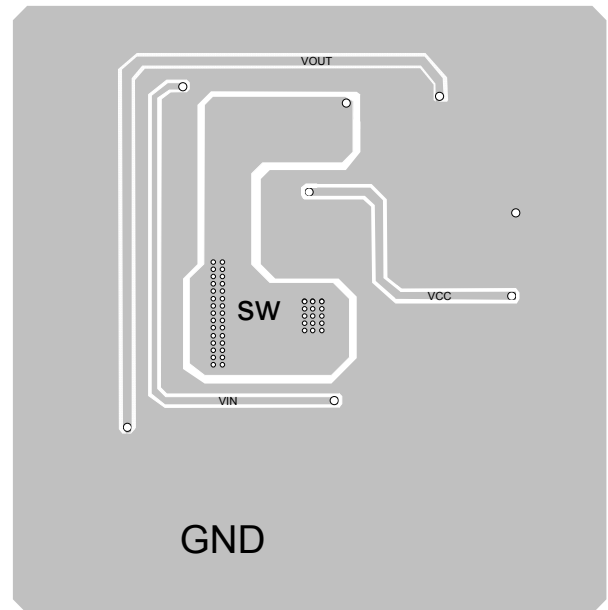
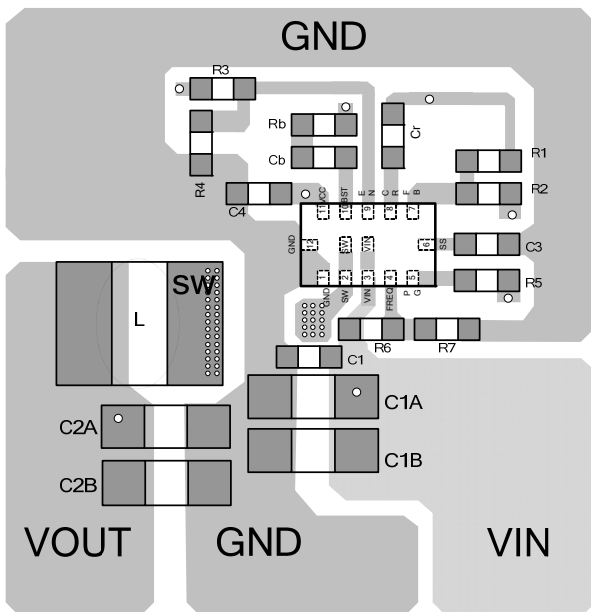

Figure 15— Sample Board Layout

Design Example

A design example is provided below when the ceramic capacitors are applied:

| | |
|-----------|------|
| V_{IN} | 12V |
| V_{OUT} | 1.2V |
| I_{OUT} | 3A |

The detailed application schematic is shown in Figure 17. The typical performance and waveforms have been showed in the Typical Characteristics Section. For more devices applications, please refer to the related Evaluation Board Datasheet.



TYPICAL APPLICATION CIRCUITS

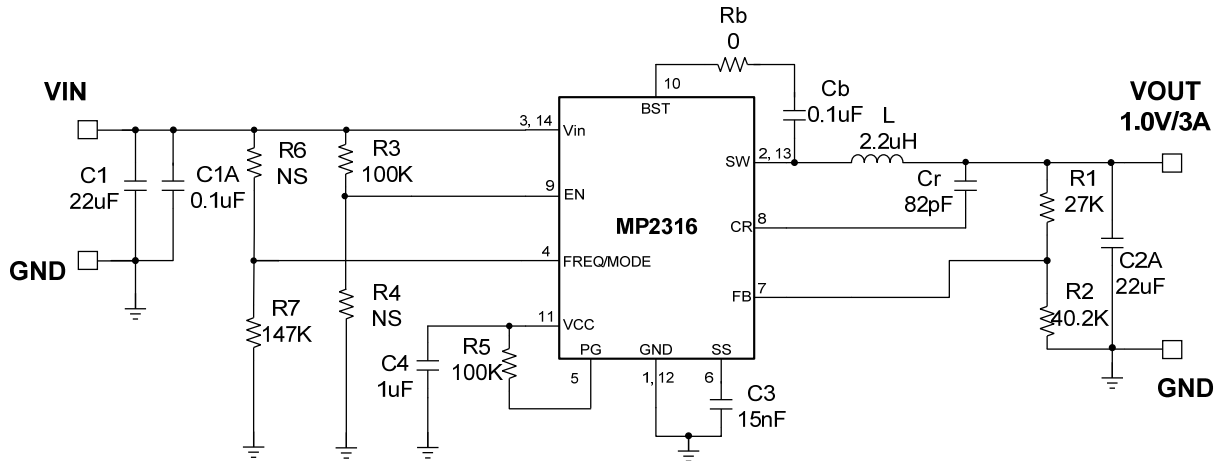

Note:

- Use R6=130k and not use R7 to set forced PWM, Use R7=147k and not use R6 to set auto PFM/PWM. The recommended R6, R7 value are basing on equation 12, 13 and optimized according to test result.
- Recommend to pull-up PG to IC VCC pin. If need pull-up PG to external power supply, please refer to the PG description in application information section.

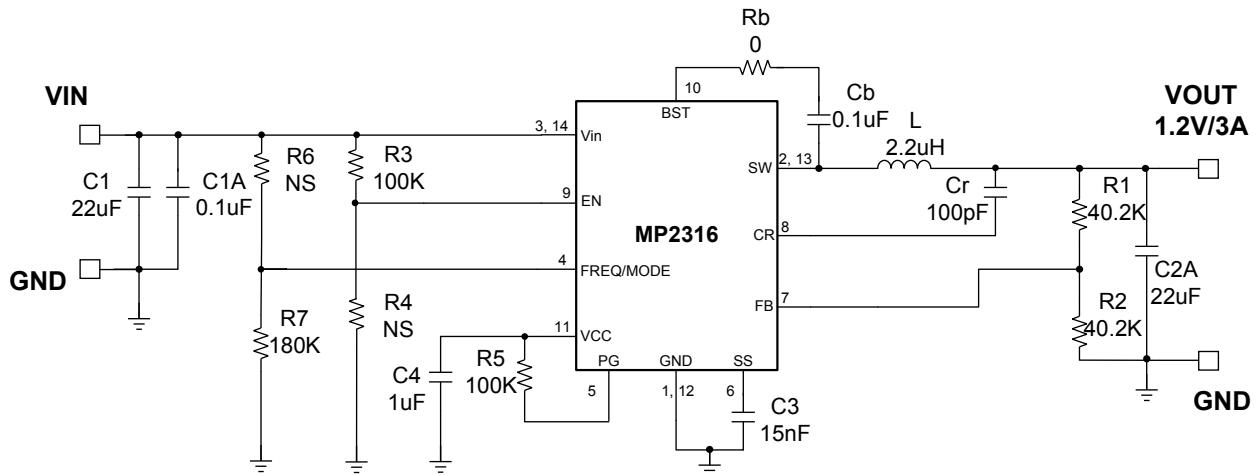
Figure 16— $V_{IN}=12V$, $V_{OUT}=1.0V$, $I_{OUT}=3A$, $F_S=500kHz$ 

Note:

- Use R6=158k and not use R7 to set forced PWM, Use R7=180k and not use R6 to set auto PFM/PWM. The recommended R6, R7 value are basing on equation 12, 13 and optimized according to test result.
- Recommend to pull-up PG to IC VCC pin. If need pull-up PG to external power supply, please refer to the PG description in application information section.

Figure 17— $V_{IN}=12V$, $V_{OUT}=1.2V$, $I_{OUT}=3A$, $F_S=500kHz$



MP2316 – 19V, 3A LOW I_Q STEP DOWN CONVERTER

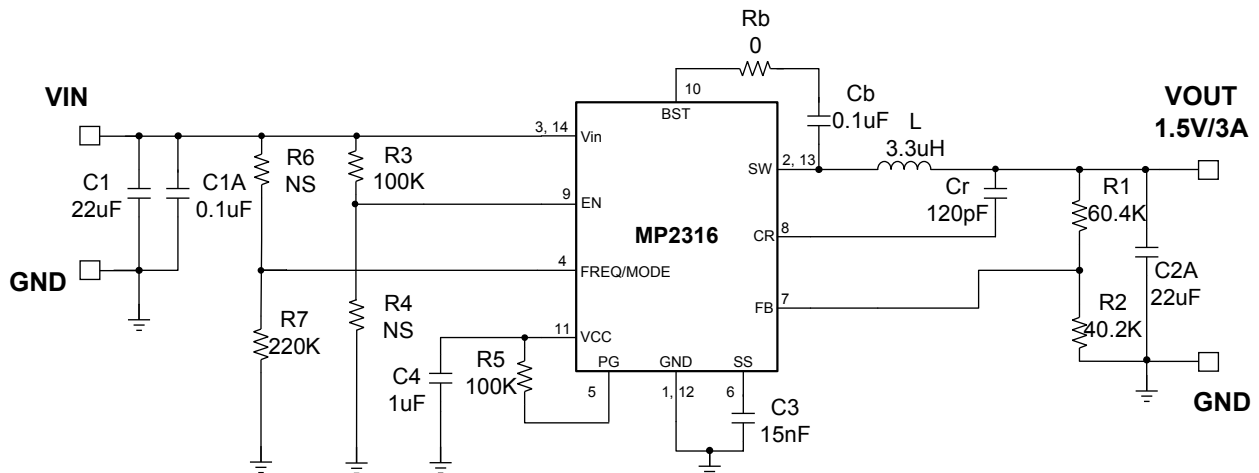

Note:

- Use R6=196k and not use R7 to set forced PWM, Use R7=220k and not use R6 to set auto PFM/PWM. The recommended R6, R7 value are basing on equation 12, 13 and optimized according to test result.
- Recommend to pull-up PG to IC VCC pin. If need pull-up PG to external power supply, please refer to the PG description in application information section.

Figure 18— V_{IN}=12V, V_{OUT}=1.5V, I_{OUT}=3A, F_S=500kHz

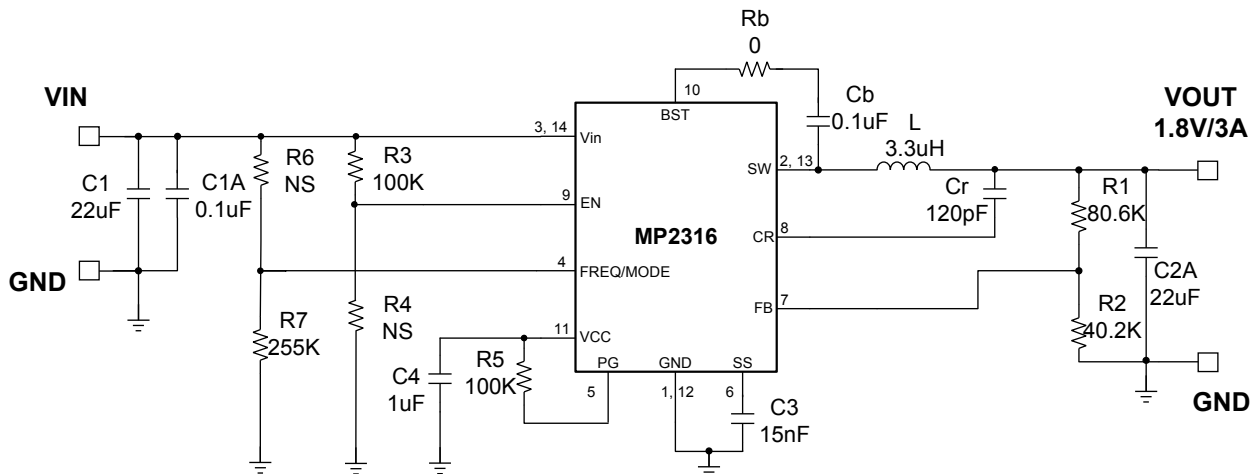

Note:

- Use R6=243k and not use R7 to set forced PWM, Use R7=255k and not use R6 to set auto PFM/PWM. The recommended R6, R7 value are basing on equation 12, 13 and optimized according to test result.
- Recommend to pull-up PG to IC VCC pin. If need pull-up PG to external power supply, please refer to the PG description in application information section.

Figure 19— V_{IN}=12V, V_{OUT}=1.8V, I_{OUT}=3A, F_S=500kHz



MP2316 – 19V, 3A LOW I_Q STEP DOWN CONVERTER

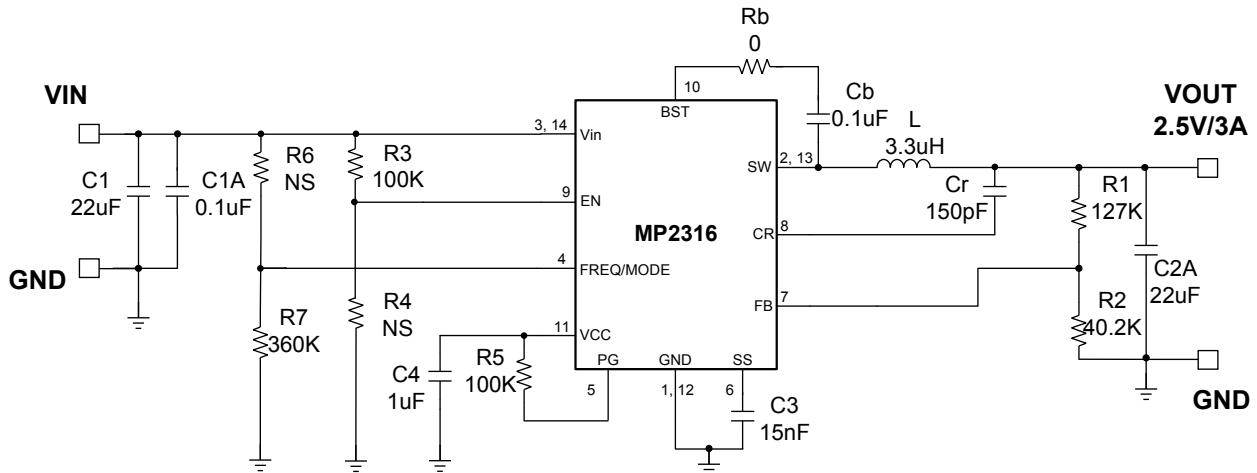

Note:

- Use R6 =348k and not use R7 to set forced PWM, Use R7= 360k and not use R6 to set auto PFM/PWM. The recommended R6, R7 value are basing on equation 12, 13 and optimized according to test result.
- Recommend to pull-up PG to IC VCC pin. If need pull-up PG to external power supply, please refer to the PG description in application information section.

Figure 20— V_{IN}=12V, V_{OUT}=2.5V, I_{OUT}=3A, F_S=500kHz

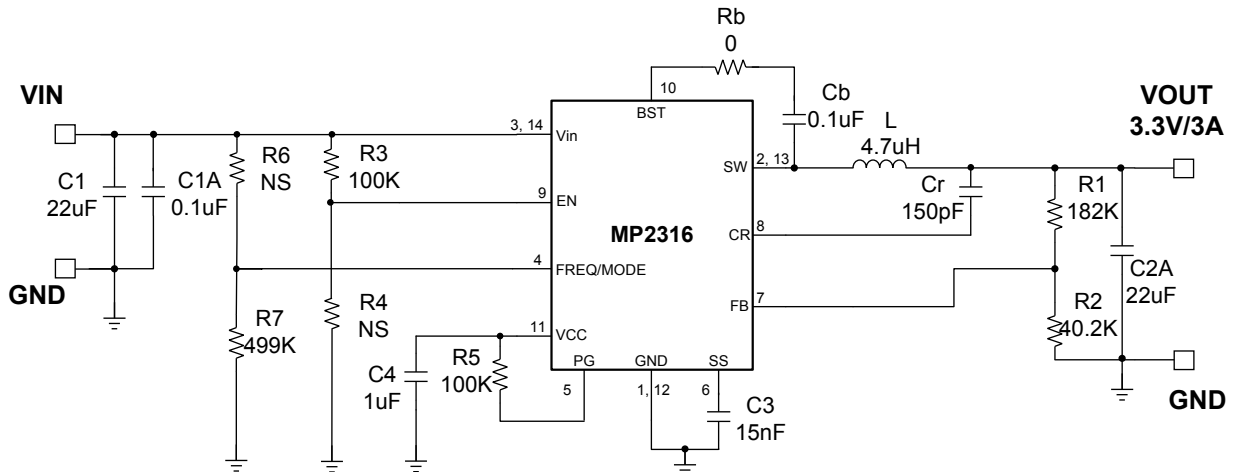

Note:

- Use R6=453k and not use R7 to set forced PWM, Use R7=499k and not use R6 to set auto PFM/PWM. The recommended R6, R7 value are basing on equation 12, 13 and optimized according to test result.
- Recommend to pull-up PG to IC VCC pin. If need pull-up PG to external power supply, please refer to the PG description in application information section.

Figure 21— V_{IN}=12V, V_{OUT}=3.3V, I_{OUT}=3A, F_S=500kHz

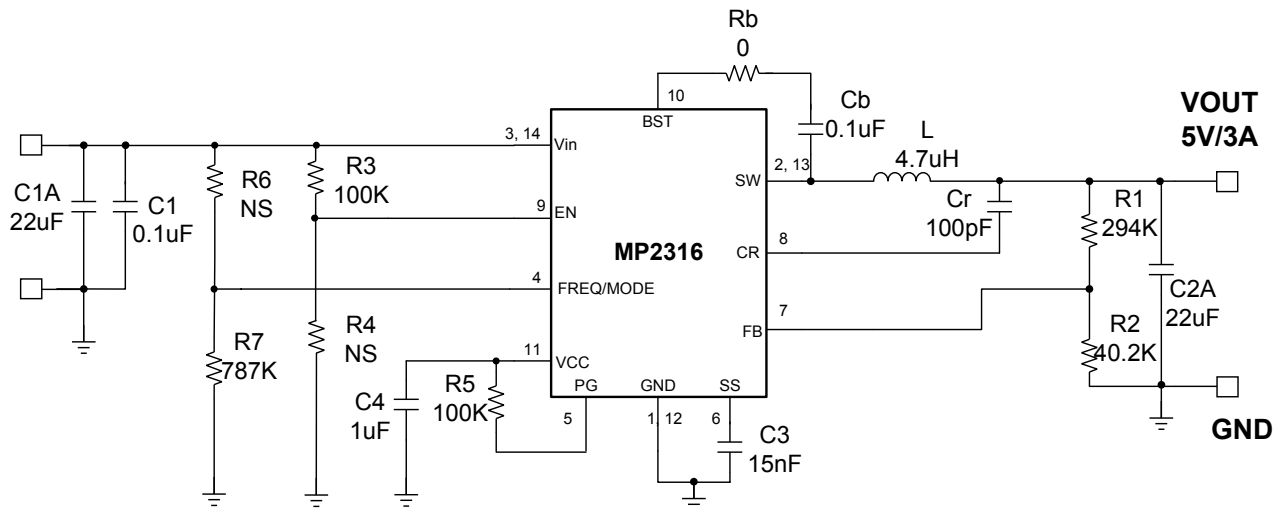
MP2316 – 19V, 3A LOW I_Q STEP DOWN CONVERTER

Note:

- Use R6=715k and not use R7 to set forced PWM, Use R7=787k and not use R6 to set auto PFM/PWM. The recommended R6, R7 value are basing on equation 12, 13 and optimized according to test result.
- Recommend to pull-up PG to IC VCC pin. If need pull-up PG to external power supply, please refer to the PG description in application information section.

Figure 22— $V_{IN}=12V$, $V_{OUT}=5V$, $I_{OUT}=3A$, $F_s=500kHz$



PACKAGE INFORMATION

QFN-14 (2mmx3mm)

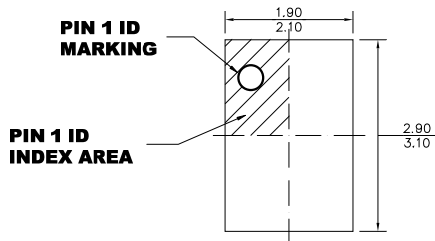

TOP VIEW

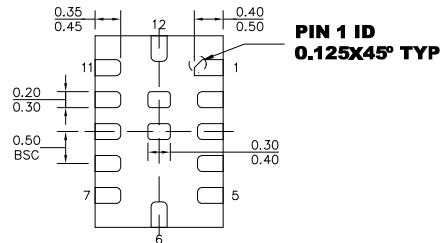

BOTTOM VIEW

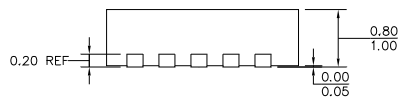

SIDE VIEW

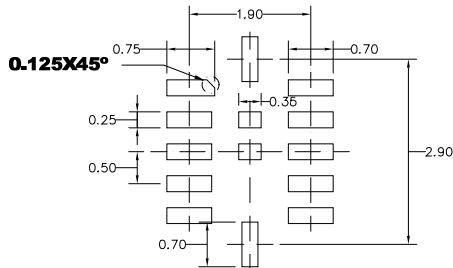

RECOMMENDED LAND PATTERN

NOTE:

- 1) ALL DIMENSIONS ARE IN MILLIMETERS.
- 2) EXPOSED PADDLE SIZE DOES NOT INCLUDE MOLD FLASH.
- 3) LEAD COPLANARITY SHALL BE 0.10 MILLIMETERS MAX.
- 4) JEDEC REFERENCE IS MO-220.
- 5) DRAWING IS NOT TO SCALE.

NOTICE: The information in this document is subject to change without notice. Users should warrant and guarantee that third party Intellectual Property rights are not infringed upon when integrating MPS products into any application. MPS will not assume any legal responsibility for any said applications.

OUR CERTIFICATE

DiGi provide top-quality products and perfect service for customer worldwide through standardization, technological innovation and continuous improvement. DiGi through third-party certification, we stricly control the quality of products and services. Welcome your RFQ to

Email: Info@DiGi-Electronics.com



Tel: +00 852-30501935

RFQ Email: Info@DiGi-Electronics.com

DiGi is a global authorized distributor of electronic components.