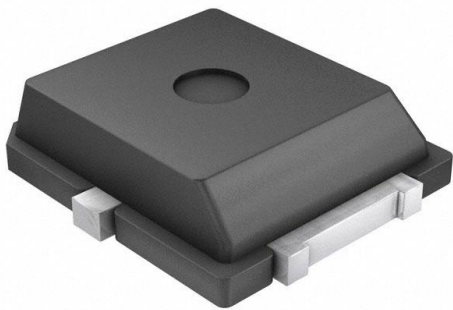


# AFT05MS006NT1 Datasheet

[www.digi-electronics.com](http://www.digi-electronics.com)



<https://www.DiGi-Electronics.com>

DiGi Electronics Part Number	AFT05MS006NT1-DG
Manufacturer	<a href="#">NXP USA Inc.</a>
Manufacturer Product Number	AFT05MS006NT1
Description	RF MOSFET LDMOS 7.5V PLD-1.5W
Detailed Description	RF Mosfet 7.5 V 100 mA 520MHz 18.3dB 6W PLD-1.5 W

This model AFT05MS006NT1 is available at DiGi Electronics.

DiGi Electronics offers a global database of semiconductor and electronic component datasheets.

We welcome your inquiries regarding pricing, lead time, or other product-related questions.

 [Request a Quote](#)

 [Datasheet Search](#)



Tel: +00 852-30501935

RFQ Email: [Info@DiGi-Electronics.com](mailto:Info@DiGi-Electronics.com)

DiGi is a global authorized distributor of electronic components.

## Purchase and inquiry

Manufacturer Product Number:

AFT05MS006NT1

Series:

-

Technology:

LDMOS

Gain:

18.3dB

Current Rating (Amps):

-

Current - Test:

100 mA

Voltage - Rated:

30 V

Package / Case:

PLD-1.5W

Base Product Number:

AFT05

Manufacturer:

NXP USA Inc.

Product Status:

Not For New Designs

Frequency:

520MHz

Voltage - Test:

7.5 V

Noise Figure:

-

Power - Output:

6W

Mounting Type:

Surface Mount

Supplier Device Package:

PLD-1.5W

## Environmental & Export classification

RoHS Status:

ROHS3 Compliant

REACH Status:

REACH Unaffected

HTSUS:

8541.29.0075

Moisture Sensitivity Level (MSL):

3 (168 Hours)

ECCN:

EAR99



# RF Power LDMOS Transistor

## High Ruggedness N-Channel Enhancement-Mode Lateral MOSFET

Designed for handheld two-way radio applications with frequencies from 136 to 941 MHz. The high gain, ruggedness and wideband performance of this device make it ideal for large-signal, common-source amplifier applications in handheld radio equipment.

### Narrowband Performance (7.5 Vdc, I<sub>DQ</sub> = 100 mA, T<sub>A</sub> = 25°C, CW)

Frequency (MHz)	G <sub>ps</sub> (dB)	η <sub>D</sub> (%)	P <sub>out</sub> (W)
520 (1)	18.3	73.0	6.0

### Wideband Performance (7.5 Vdc, T<sub>A</sub> = 25°C, CW)

Frequency (MHz)	P <sub>in</sub> (W)	G <sub>ps</sub> (dB)	η <sub>D</sub> (%)	P <sub>out</sub> (W)
136–174	0.19	15.5	60.0	6.0
440–520 (2)	0.15	16.3	65.0	6.4
760–870 (3)	0.20	15.2	58.5	6.7

### Load Mismatch/Ruggedness

Frequency (MHz)	Signal Type	VSWR	P <sub>in</sub> (W)	Test Voltage	Result
520 (1)	CW	> 65:1 at all Phase Angles	0.12 (3 dB Overdrive)	10.8	No Device Degradation

1. Measured in 520 MHz narrowband test circuit.
2. Measured in 440–520 MHz UHF broadband reference circuit.
3. Measured in 760–870 MHz UHF broadband reference circuit.

### Features

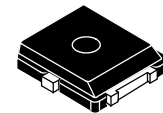
- Characterized for Operation from 136 to 941 MHz
- Unmatched Input and Output Allowing Wide Frequency Range Utilization
- Integrated ESD Protection
- Integrated Stability Enhancements
- Wideband — Full Power Across the Band
- Exceptional Thermal Performance
- Extreme Ruggedness
- High Linearity for: TETRA, SSB
- In Tape and Reel. T1 Suffix = 1,000 Units, 16 mm Tape Width, 7-inch Reel.

### Typical Applications

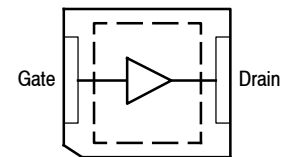
- Output Stage VHF Band Handheld Radio
- Output Stage UHF Band Handheld Radio
- Output Stage for 700–800 MHz Handheld Radio

## AFT05MS006NT1

136–941 MHz, 6.0 W, 7.5 V  
**WIDEBAND  
 RF POWER LDMOS TRANSISTOR**



PLD-1.5W



Note: The center pad on the backside of the package is the source terminal for the transistor.

**Figure 1. Pin Connections**

**Table 1. Maximum Ratings**

Rating	Symbol	Value	Unit
Drain-Source Voltage	$V_{DSS}$	-0.5, +30	Vdc
Gate-Source Voltage	$V_{GS}$	-6.0, +12	Vdc
Operating Voltage	$V_{DD}$	12.5, +0	Vdc
Storage Temperature Range	$T_{stg}$	-65 to +150	°C
Case Operating Temperature Range	$T_C$	-40 to +150	°C
Operating Junction Temperature Range (1,2)	$T_J$	-40 to +150	°C
Total Device Dissipation @ $T_C = 25^\circ\text{C}$ Derate above 25°C	$P_D$	125 1.0	W W/°C

**Table 2. Thermal Characteristics**

Characteristic	Symbol	Value (2,3)	Unit
Thermal Resistance, Junction to Case Case Temperature 79° C, 6.0 W CW, 7.5 Vdc, $I_{DQ} = 100$ mA, 520 MHz	$R_{\theta JC}$	1.0	°C/W

**Table 3. ESD Protection Characteristics**

Test Methodology	Class
Human Body Model (per JESD22-A114)	2, passes 2500 V
Machine Model (per EIA/JESD22-A115)	A, passes 150 V
Charge Device Model (per JESD22-C101)	IV, passes 2000 V

**Table 4. Moisture Sensitivity Level**

Test Methodology	Rating	Package Peak Temperature	Unit
Per JESD22-A113, IPC/JEDEC J-STD-020	3	260	°C

**Table 5. Electrical Characteristics** ( $T_A = 25^\circ\text{C}$  unless otherwise noted)

Characteristic	Symbol	Min	Typ	Max	Unit
<b>Off Characteristics</b>					
Zero Gate Voltage Drain Leakage Current ( $V_{DS} = 30$ Vdc, $V_{GS} = 0$ Vdc)	$I_{DSS}$	—	—	10	$\mu\text{Adc}$
Zero Gate Voltage Drain Leakage Current ( $V_{DS} = 7.5$ Vdc, $V_{GS} = 0$ Vdc)	$I_{DSS}$	—	—	2	$\mu\text{Adc}$
Gate-Source Leakage Current ( $V_{GS} = 5$ Vdc, $V_{DS} = 0$ Vdc)	$I_{GSS}$	—	—	600	nAdc
<b>On Characteristics</b>					
Gate Threshold Voltage ( $V_{DS} = 10$ Vdc, $I_D = 78$ $\mu\text{Adc}$ )	$V_{GS(th)}$	1.8	2.2	2.6	Vdc
Drain-Source On-Voltage ( $V_{GS} = 10$ Vdc, $I_D = 0.78$ Adc)	$V_{DS(on)}$	—	0.15	—	Vdc
Forward Transconductance ( $V_{DS} = 7.5$ Vdc, $I_D = 4.7$ Adc)	$g_{fs}$	—	4.4	—	S

1. Continuous use at maximum temperature will affect MTTF.
2. MTTF calculator available at <http://www.freescale.com/rf>. Select Software & Tools/Development Tools/Calculators to access MTTF calculators by product.
3. Refer to AN1955, *Thermal Measurement Methodology of RF Power Amplifiers*. Go to <http://www.freescale.com/rf>. Select Documentation/Application Notes - AN1955.

(continued)

**Table 5. Electrical Characteristics** ( $T_A = 25^\circ\text{C}$  unless otherwise noted) (continued)

Characteristic	Symbol	Min	Typ	Max	Unit
<b>Dynamic Characteristics</b>					
Reverse Transfer Capacitance ( $V_{DS} = 7.5\text{ Vdc} \pm 30\text{ mV(rms)ac}$ @ 1 MHz, $V_{GS} = 0\text{ Vdc}$ )	$C_{rss}$	—	1.7	—	pF
Output Capacitance ( $V_{DS} = 7.5\text{ Vdc} \pm 30\text{ mV(rms)ac}$ @ 1 MHz, $V_{GS} = 0\text{ Vdc}$ )	$C_{oss}$	—	47	—	pF
Input Capacitance ( $V_{DS} = 7.5\text{ Vdc}$ , $V_{GS} = 0\text{ Vdc} \pm 30\text{ mV(rms)ac}$ @ 1 MHz)	$C_{iss}$	—	75	—	pF
<b>Functional Tests</b> (In Freescale Test Fixture, 50 ohm system) $V_{DD} = 7.5\text{ Vdc}$ , $I_{DQ} = 100\text{ mA}$ , $P_{in} = 19.5\text{ dBm}$ , $f = 520\text{ MHz}$					
Common-Source Amplifier Output Power	$P_{out}$	—	6.0	—	W
Drain Efficiency	$\eta_D$	—	73.0	—	%
<b>Load Mismatch/Ruggedness</b> (In Freescale Test Fixture, 50 ohm system) $I_{DQ} = 100\text{ mA}$					
Frequency (MHz)	Signal Type	VSWR	$P_{in}$ (W)	Test Voltage, $V_{DD}$	Result
520	CW	> 65:1 at all Phase Angles	0.12 (3 dB Overdrive)	10.8	No Device Degradation

### TYPICAL CHARACTERISTICS

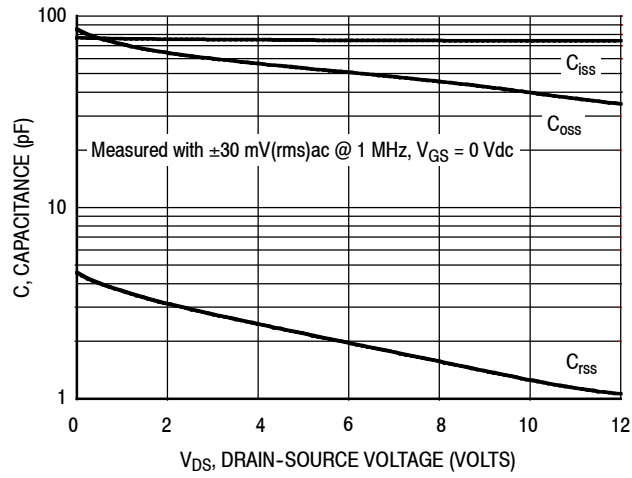
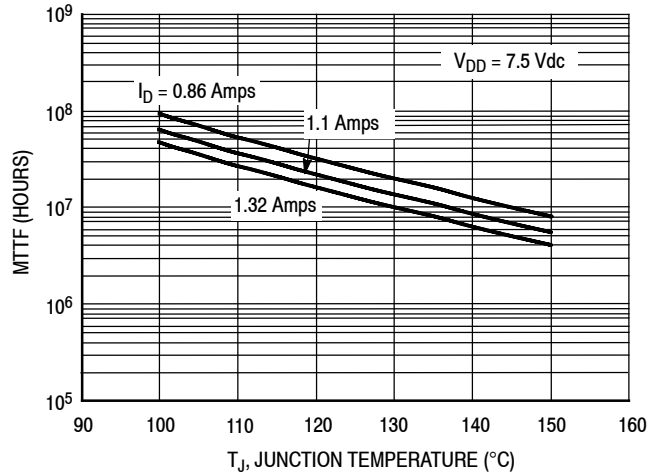


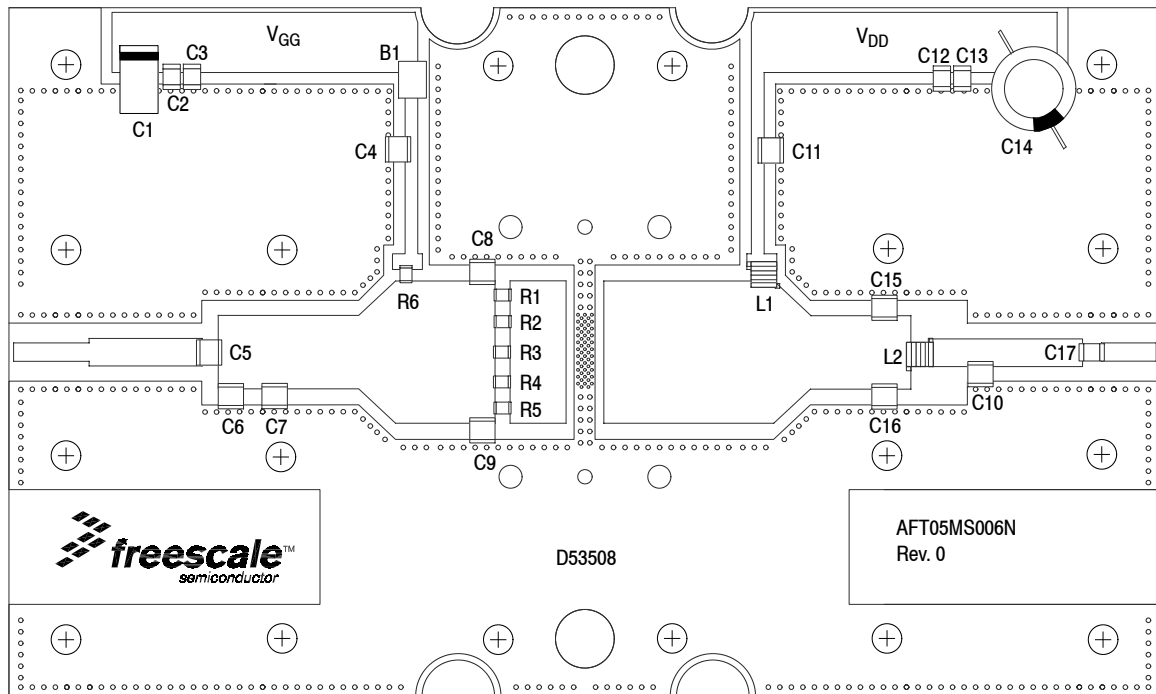
Figure 2. Capacitance versus Drain-Source Voltage



**Note:** MTTF value represents the total cumulative operating time under indicated test conditions.

MTTF calculator available at <http://www.freescale.com/rf>. Select Software & Tools/Development Tools/Calculators to access MTTF calculators by product.

Figure 3. MTTF versus Junction Temperature — CW

**520 MHz NARROWBAND PRODUCTION TEST FIXTURE**

**Figure 4. AFT05MS006NT1 Narrowband Test Circuit Component Layout — 520 MHz**
**Table 6. AFT05MS006NT1 Narrowband Test Circuit Component Designations and Values — 520 MHz**

Part	Description	Part Number	Manufacturer
B1	Short RF Bead	2743019447	Fair-Rite
C1	22 $\mu$ F, 35 V Tantalum Capacitor	T491X226K035AT	Kemet
C2, C13	0.1 $\mu$ F Chip Capacitors	CDR33BX104AKWS	AVX
C3, C12	0.01 $\mu$ F Chip Capacitors	C0805C103K5RAC	Kemet
C4, C11	180 pF Chip Capacitors	ATC100B181JT300XT	ATC
C5	9.1 pF Chip Capacitor	ATC100B9R1CT500XT	ATC
C6, C7	15 pF Chip Capacitors	ATC100B150JT500XT	ATC
C8, C9	27 pF Chip Capacitors	ATC100B270JT500XT	ATC
C10	2.7 pF Chip Capacitor	ATC100B2R7BT500XT	ATC
C14	330 $\mu$ F, 35 V Electrolytic Capacitor	MCGPR35V337M10X16-RH	Multicomp
C15, C16	20 pF Chip Capacitors	ATC100B200JT500XT	ATC
C17	16 pF Chip Capacitor	ATC100B160JT500XT	ATC
L1	8.0 nH, 3 Turn Inductor	A03TKLC	Coilcraft
L2	5 nH, 2 Turn Inductor	A02TKLC	Coilcraft
R1, R2, R3, R4, R5	1.5 $\Omega$ , 1/4 W Chip Resistors	RC1206FR-071R5L	Yageo
R6	27 $\Omega$ , 1/4 W Chip Resistor	CRCW120627R0FKEA	Vishay
PCB	Rogers RO4350B, 0.030", $\epsilon_r = 3.66$	D53508	MTL

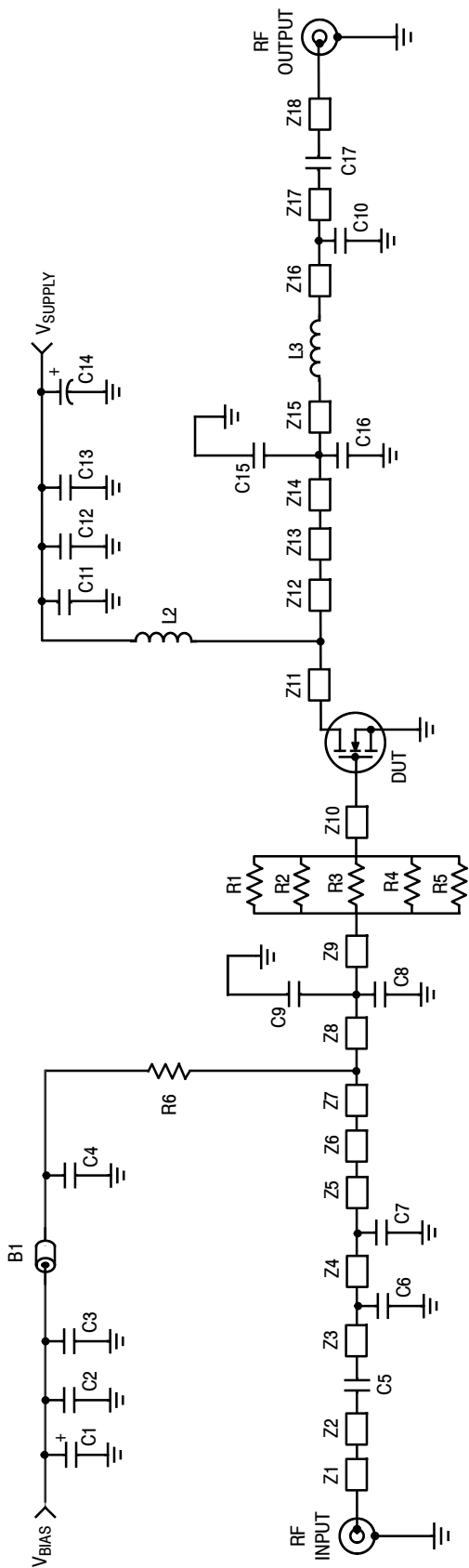


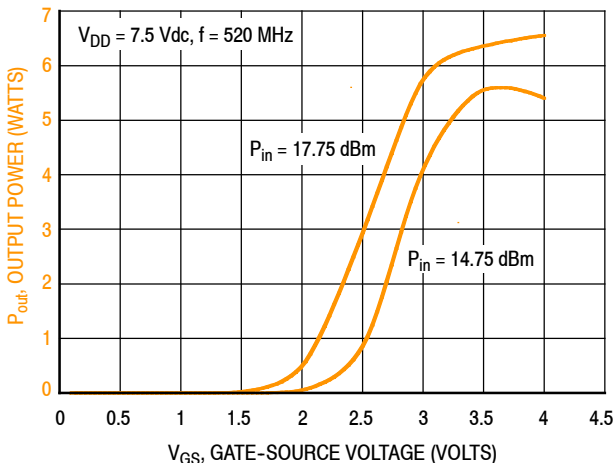
Figure 5. AFT05MS006NT1 Narrowband Test Circuit Schematic — 520 MHz

Table 7. AFT05MS006NT1 Narrowband Test Circuit Microstrips — 520 MHz

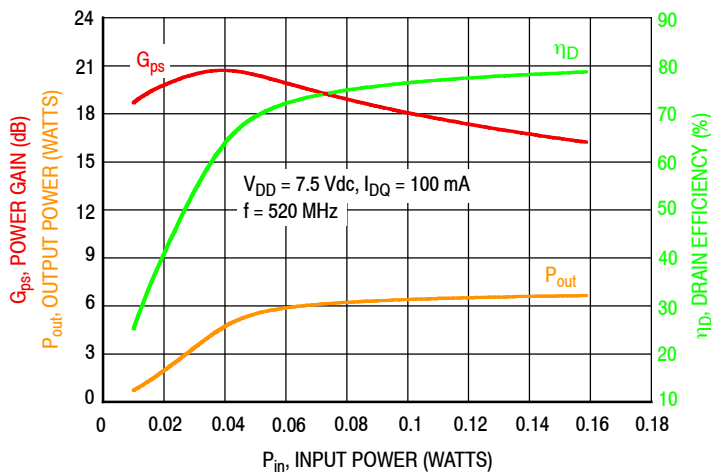
Microstrip	Description
Z1	0.328" x 0.080" Microstrip
Z2	0.490" x 0.120" Microstrip
Z3	0.055" x 0.320" Microstrip
Z4	0.190" x 0.320" Microstrip
Z5	0.365" x 0.320" Microstrip
Z6	0.160" x 0.320" x 0.620" Taper Microstrip
Z7	0.045" x 0.620" Microstrip
Z8	0.332" x 0.620" Microstrip
Z9	0.055" x 0.620" Microstrip

Microstrip	Description
Z10	0.243" x 0.620" Microstrip
Z11	0.692" x 0.620" Microstrip
Z12	0.045" x 0.620" Microstrip
Z13	0.162" x 0.320" x 0.620" Taper Microstrip
Z14	0.319" x 0.320" Microstrip
Z15	0.115" x 0.320" Microstrip
Z16	0.222" x 0.120" Microstrip
Z17	0.443" x 0.120" Microstrip
Z18	0.238" x 0.080" Microstrip

**TYPICAL CHARACTERISTICS — 520 MHz NARROWBAND REFERENCE CIRCUIT**



**Figure 6. Output Power versus Gate-Source Voltage**



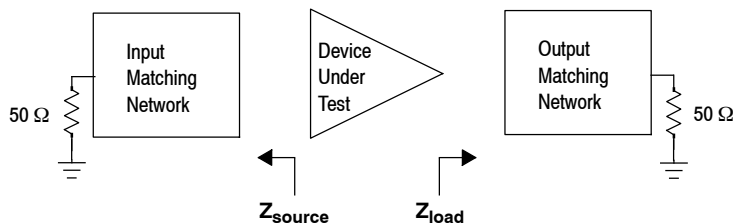
**Figure 7. Power Gain, Drain Efficiency and Output Power versus Input Power**

$V_{DD} = 7.5 \text{ Vdc}, I_{DQ} = 100 \text{ mA}, P_{out} = 6.0 \text{ W Avg.}$

f MHz	$Z_{source}$ Ω	$Z_{load}$ Ω
520	$1.14 + j2.28$	$1.78 + j1.71$

$Z_{source}$  = Test circuit impedance as measured from gate to ground.

$Z_{load}$  = Test circuit impedance as measured from drain to ground.



**Figure 8. Narrowband Series Equivalent Source and Load Impedance — 520 MHz**

### 440–520 MHz UHF BROADBAND REFERENCE CIRCUIT

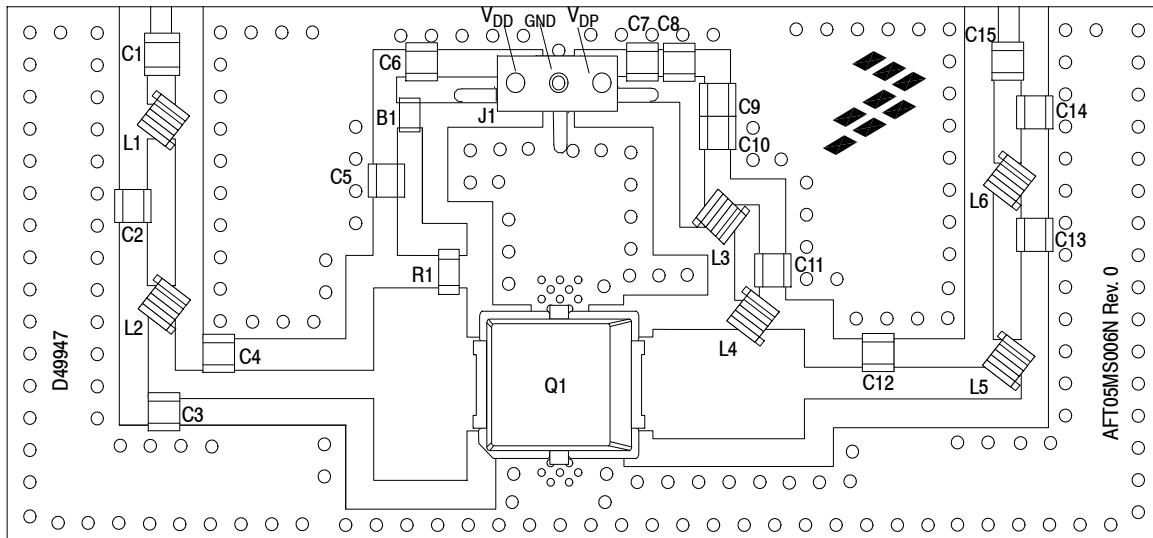
**Table 8. 440–520 MHz UHF Broadband Performance** (In Freescale Reference Circuit, 50 ohm system)

$V_{DD} = 7.5$  Volts,  $I_{DQ} = 100$  mA,  $T_A = 25^\circ\text{C}$ , CW

Frequency (MHz)	$P_{in}$ (W)	$G_{ps}$ (dB)	$\eta_D$ (%)	$P_{out}$ (W)
440	0.13	16.7	63.7	5.9
480	0.08	18.6	68.5	6.1
520	0.11	17.5	73.1	6.0

**Table 9. Load Mismatch/Ruggedness** (In Freescale Reference Circuit)

Frequency (MHz)	Signal Type	VSWR	$P_{in}$ (W)	Test Voltage, $V_{DD}$	Result
480	CW	> 65:1 at all Phase Angles	0.19 (3 dB Overdrive)	10.8	No Device Degradation

**440–520 MHz UHF Broadband Reference Circuit**

**Figure 9. AFT05MS006NT1 UHF Broadband Reference Circuit Component Layout — 440–520 MHz**
**Table 10. AFT05MS006NT1 UHF Broadband Reference Circuit Component Designations and Values — 440–520 MHz**

Part	Description	Part Number	Manufacturer
B1	30 $\Omega$ , 6 A Ferrite Bead	MPZ2012S300A	Fair-Rite
C1	18 pF Chip Capacitor	ATC600F180JT250XT	ATC
C2, C3, C11	15 pF Chip Capacitors	ATC600F150JT250XT	ATC
C4	56 pF Chip Capacitor	ATC600F560JT250XT	ATC
C5	100 pF Chip Capacitor	ATC600F100JT250XT	ATC
C6, C7	0.1 $\mu$ F Chip Capacitors	GRM21BR71H104KA01B	Murata
C8	0.01 $\mu$ F Chip Capacitor	GRM21BR72A103KA01B	Murata
C9	240 pF Chip Capacitor	ATC600F241JT250XT	ATC
C10	2.2 $\mu$ F Chip Capacitor	GRM31CR71H225KA88L	Murata
C12	39 pF Chip Capacitor	ATC600F390JT250XT	ATC
C13	18 pF Chip Capacitor	ATC600F180JT250XT	ATC
C14	5.1 pF Chip Capacitor	ATC600F5R1BT250XT	ATC
C15	100 pF Chip Capacitor	ATC600F101JT250XT	ATC
J1	Right-Angle Breakaway Headers (3 pins)	22-28-8360	Molex
L1	5.5 nH Inductor	0806SQ5N5	Coilcraft
L2	6 nH Inductor	0806SQ6N0	Coilcraft
L3, L4	16.6 nH Inductors	0908SQ17N	Coilcraft
L5	1.65 nH Inductor	0906-2JLC	Coilcraft
L6	8.1 nH Inductor	0908SQ8N1	Coilcraft
Q1	RF Power LDMOS Transistor	AFT05MS006NT1	Freescale
R1	20 $\Omega$ , 1/4 W Chip Resistor	CRCW120620R0FKEA	Vishay
PCB	0.020", $\epsilon_r = 4.8$ , Shengyi S1000-2	D49947	MTL

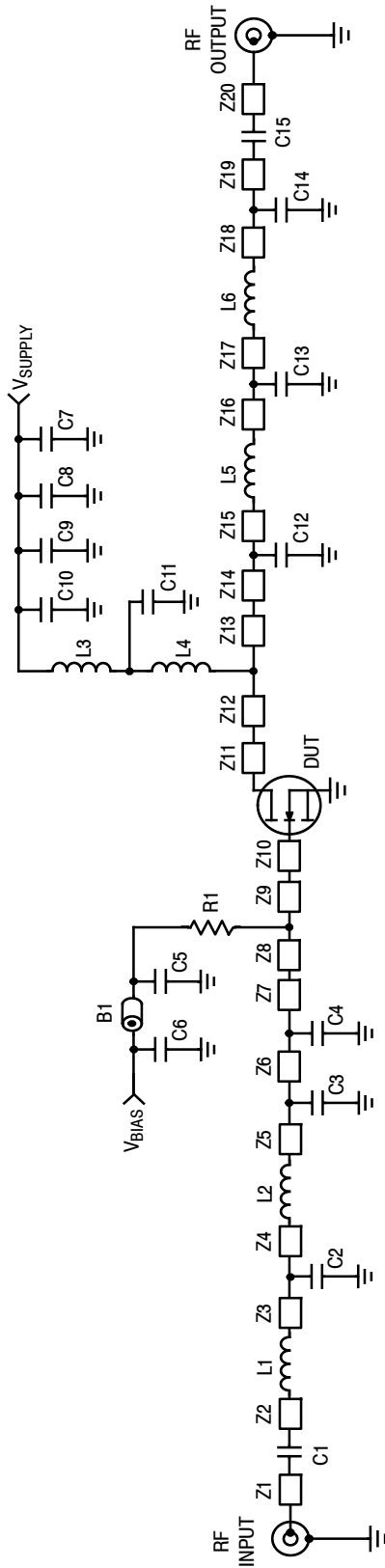
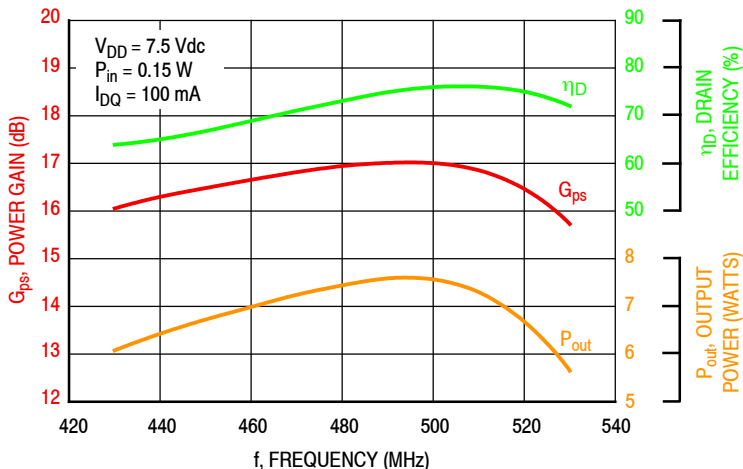


Figure 10. AFT05MS006NT1 UHF Broadband Reference Circuit Schematic — 440-520 MHz

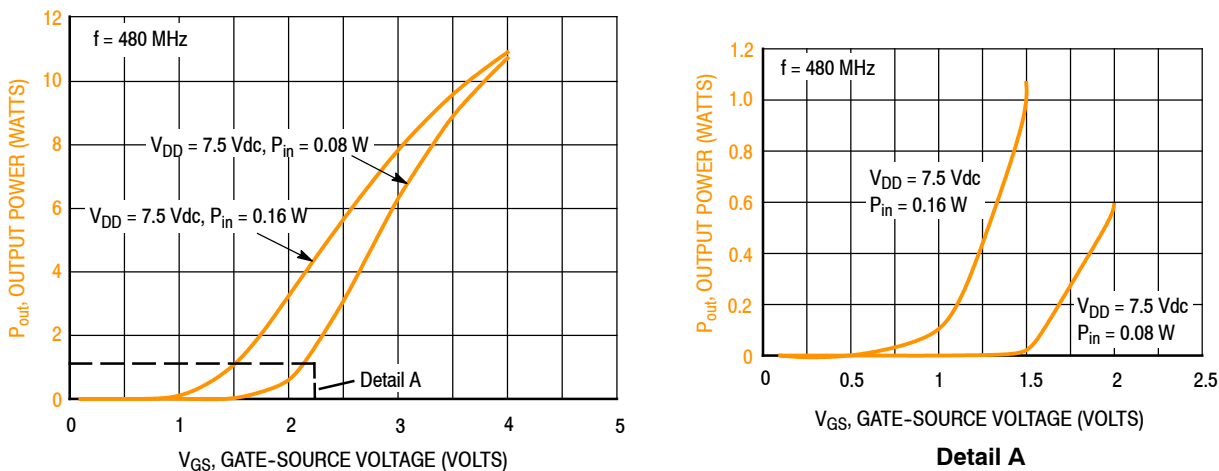
Table 11. AFT05MS006NT1 UHF Broadband Reference Circuit Microstrips — 440-520 MHz

Microstrip	Description	Microstrip	Description
Z1	0.060" x 0.034" Microstrip	Z8	0.123" x 0.300" Microstrip
Z2	0.052" x 0.046" Microstrip	Z9	0.029" x 0.300" Microstrip
Z3	0.105" x 0.046" Microstrip	Z10	0.070" x 0.146" Microstrip
Z4	0.124" x 0.046" Microstrip	Z11	0.070" x 0.146" Microstrip
Z5	0.127" x 0.044" Microstrip	Z12	0.153" x 0.170" Microstrip
Z6	0.093" x 0.044" Microstrip	Z13	0.094" x 0.170" Microstrip
Z7	0.253" x 0.044" Microstrip	Z14	0.120" x 0.049" Microstrip
Z15	0.235" x 0.049" Microstrip		
Z16	0.163" x 0.046" Microstrip		
Z17	0.065" x 0.046" Microstrip		
Z18	0.079" x 0.044" Microstrip		
Z19	0.056" x 0.044" Microstrip		
Z20	0.060" x 0.034" Microstrip		

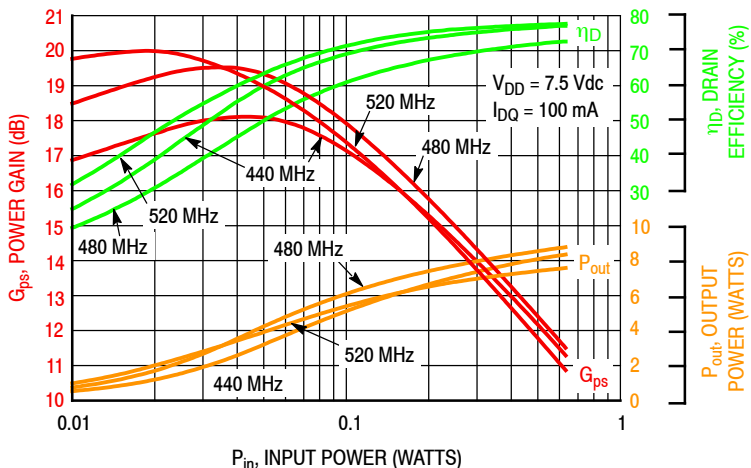
**TYPICAL CHARACTERISTICS — 440-520 MHz UHF BROADBAND REFERENCE CIRCUIT**



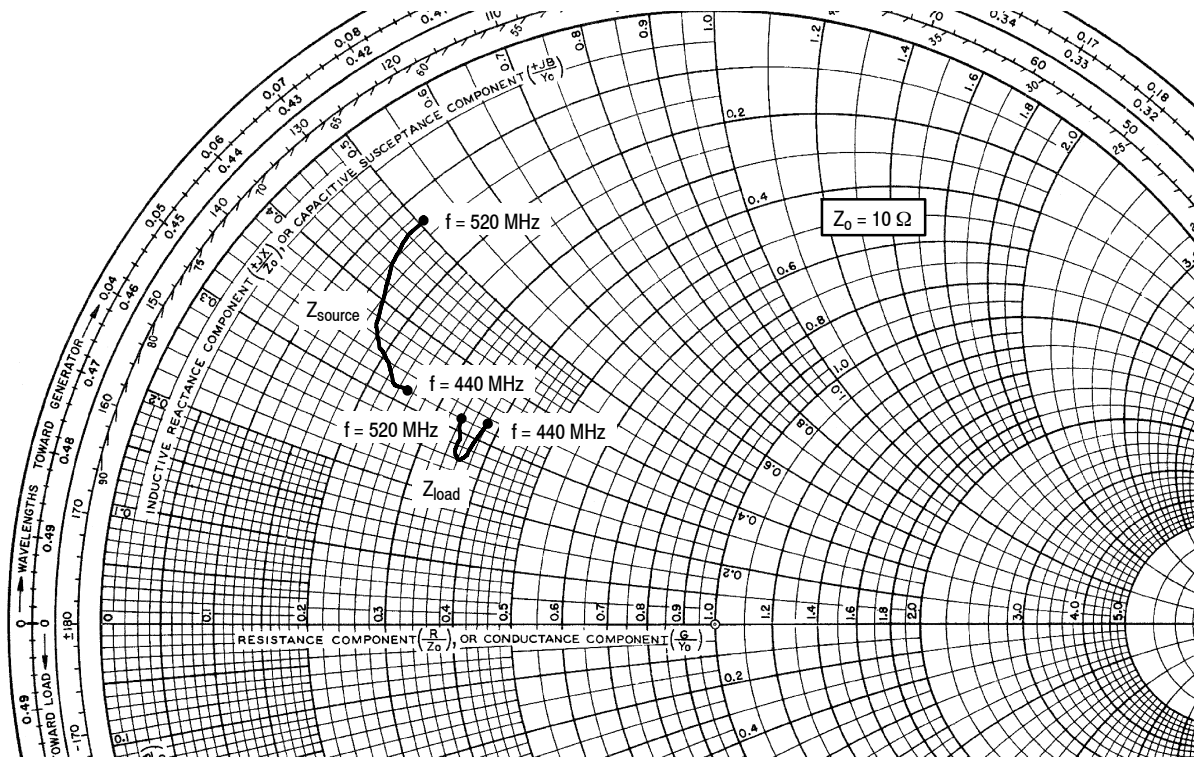
**Figure 11. Power Gain, Drain Efficiency and Output Power versus Frequency at a Constant Input Power**



**Figure 12. Output Power versus Gate-Source Voltage**

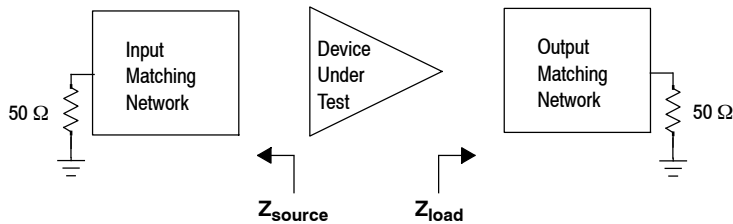


**Figure 13. Power Gain, Drain Efficiency and Output Power versus Input Power and Frequency**

**440-520 MHz UHF BROADBAND REFERENCE CIRCUIT**

 $V_{DD} = 7.5 \text{ Vdc}$ ,  $I_{DQ} = 100 \text{ mA}$ ,  $P_{out} = 6 \text{ W Avg.}$ 

f MHz	$Z_{source}$ $\Omega$	$Z_{load}$ $\Omega$
440	$2.46 + j3.15$	$3.80 + j3.27$
450	$2.30 + j3.23$	$3.70 + j2.77$
460	$2.11 + j3.35$	$3.69 + j2.66$
470	$1.90 + j3.48$	$3.60 + j2.61$
480	$1.71 + j3.72$	$3.54 + j2.68$
490	$1.56 + j4.01$	$3.50 + j2.78$
500	$1.43 + j4.37$	$3.46 + j2.92$
510	$1.33 + j4.75$	$3.42 + j3.09$
520	$1.28 + j5.10$	$3.37 + j3.22$

 $Z_{source}$  = Test circuit impedance as measured from gate to ground.

 $Z_{load}$  = Test circuit impedance as measured from drain to ground.

**Figure 14. UHF Broadband Series Equivalent Source and Load Impedance — 440-520 MHz**

### 760-870 MHz UHF BROADBAND REFERENCE CIRCUIT

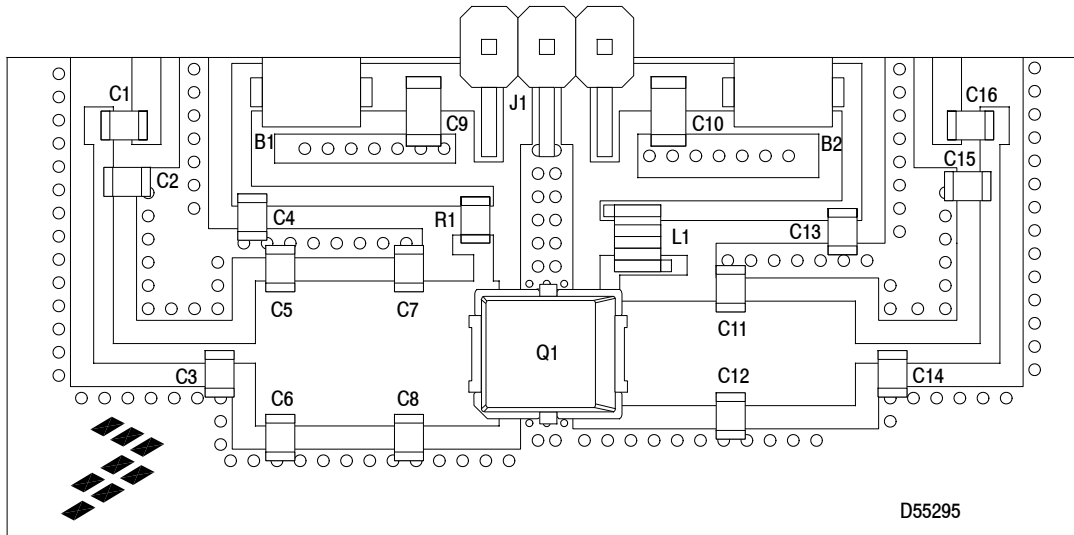
**Table 12. 760-870 MHz UHF Broadband Performance** (In Freescale Reference Circuit, 50 ohm system)

$V_{DD} = 7.5$  Volts,  $I_{DQ} = 100$  mA,  $T_A = 25^\circ\text{C}$ , CW

Frequency (MHz)	$P_{in}$ (W)	$G_{ps}$ (dB)	$\eta_D$ (%)	$P_{out}$ (W)
760	0.12	16.6	50.4	6.0
815	0.13	16.1	58.1	6.0
870	0.16	15.0	60.0	6.0

**Table 13. Load Mismatch/Ruggedness** (In Freescale Reference Circuit)

Frequency (MHz)	Signal Type	VSWR	$P_{in}$ (W)	Test Voltage, $V_{DD}$	Result
815	CW	> 65:1 at all Phase Angles	0.4 (3 dB Overdrive)	9.0	No Device Degradation

**760-870 MHz UHF Broadband Reference Circuit**

**Figure 15. AFT05MS006NT1 UHF Broadband Reference Circuit Component Layout — 760-870 MHz**
**Table 14. AFT05MS006NT1 UHF Broadband Reference Circuit Component Designations and Values — 760-870 MHz**

Part	Description	Part Number	Manufacturer
B1, B2	RF Beads	2743019447	Fair-Rite
C1, C5, C6, C7, C8	20 pF Chip Capacitors	GQM2195C2E200GB12D	Murata
C2	8.2 pF Chip Capacitor	GQM2195C2E8R2BB12D	Murata
C3	10 pF Chip Capacitor	GQM2195C2E100FB12D	Murata
C4, C13	56 pF Chip Capacitors	GQM2195C2E560GB12D	Murata
C9	1 $\mu$ F Chip Capacitor	GRM31MR71H105KA88L	Murata
C10	10 $\mu$ F Chip Capacitor	GRM31CR61H106KA12L	Murata
C11, C12	15 pF Chip Capacitors	GQM2195C2E150FB12D	Murata
C14, C15	5.6 pF Chip Capacitors	GQM2195C2E5R6BB12D	Murata
C16	100 pF Chip Capacitor	GQM2195C2E101GB12D	Murata
J1	Right-Angle Breakaway Headers (3 pins)	22-28-8360	Molex
L1	22 nH Air Core Inductor	0908SQ-22NJL	Coilcraft
Q1	RF Power LDMOS Transistor	AFT05MS006NT1	Freescale
R1	200 $\Omega$ , 1/8 W Chip Resistor	CRCW0805200RJNEA	Vishay
PCB	0.020", $\epsilon_r = 4.8$ , FR4	D55295	MTL

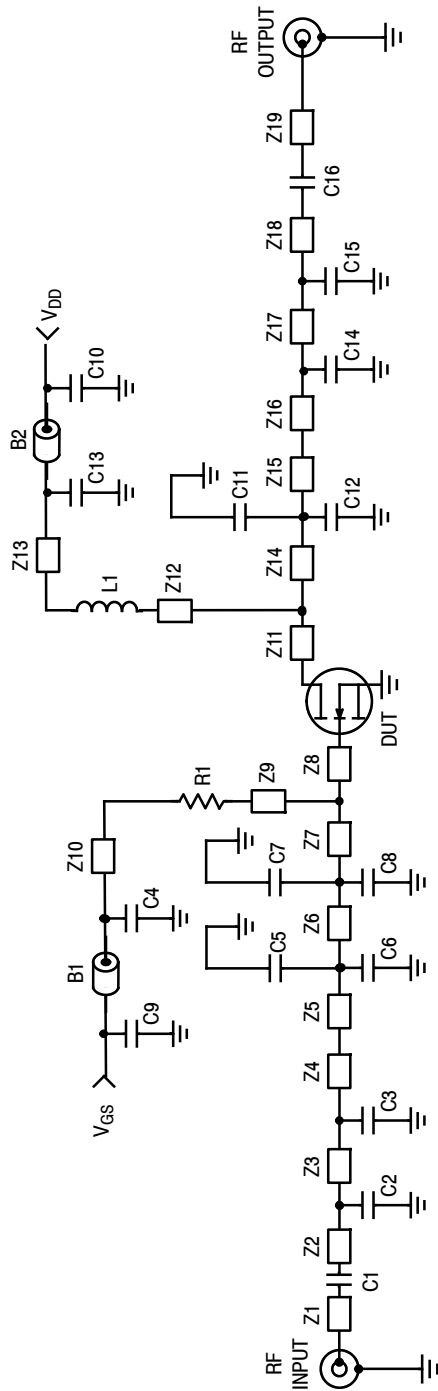
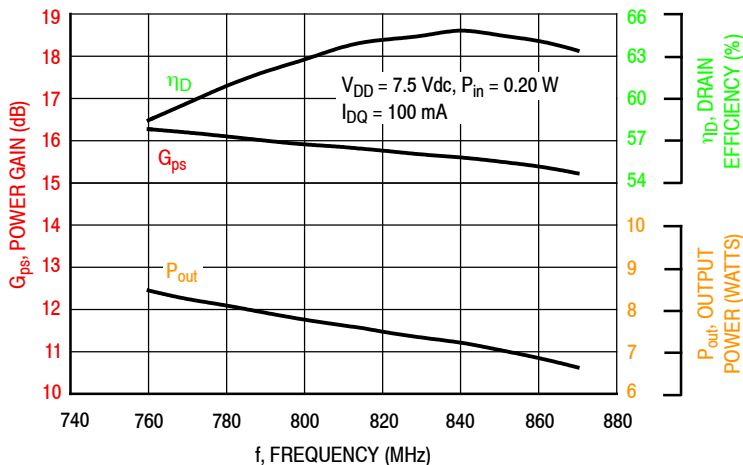


Figure 16. AFT05MS006NT1 UHF Broadband Reference Circuit Schematic — 760-870 MHz

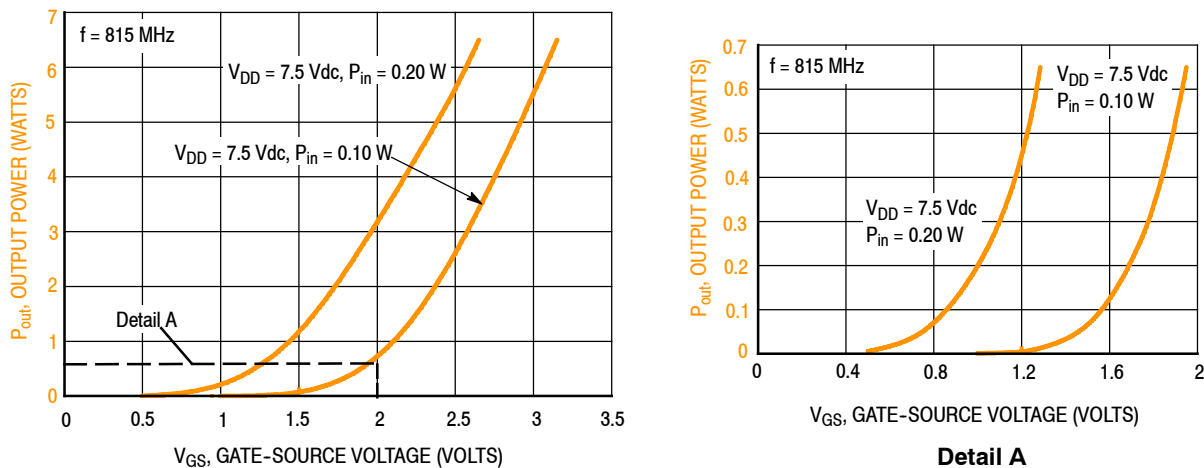
Table 15. AFT05MS006NT1 UHF Broadband Reference Circuit Microstrips — 760-870 MHz

Microstrip	Description	Microstrip	Description
Z1	0.150" x 0.050" Microstrip	Z8	0.027" x 0.250" Microstrip
Z2	0.155" x 0.034" Microstrip	Z9	0.066" x 0.034" Microstrip
Z3	0.430" x 0.034" Microstrip	Z10	0.386" x 0.034" Microstrip
Z4	0.065" x 0.034" Microstrip	Z11	0.027" x 0.180" Microstrip
Z5	0.040" x 0.250" Microstrip	Z12	0.160" x 0.034" Microstrip
Z6	0.222" x 0.250" Microstrip	Z13	0.350" x 0.034" Microstrip
Z7	0.130" x 0.250" Microstrip	Z14	0.210" x 0.180" Microstrip
Z15	0.215" x 0.180" Microstrip		
Z16	0.065" x 0.034" Microstrip		
Z17	0.430" x 0.034" Microstrip		
Z18	0.120" x 0.034" Microstrip		
Z19	0.150" x 0.050" Microstrip		

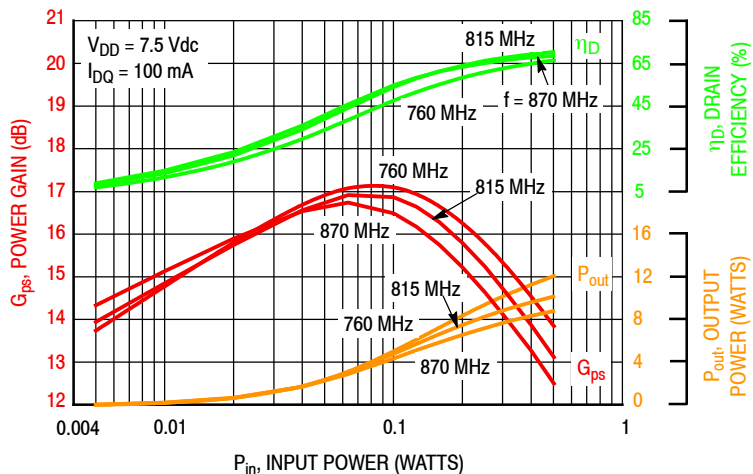
### TYPICAL CHARACTERISTICS — 760–870 MHz UHF BROADBAND REFERENCE CIRCUIT



**Figure 17. Power Gain, Drain Efficiency and Output Power versus Frequency at a Constant Input Power**

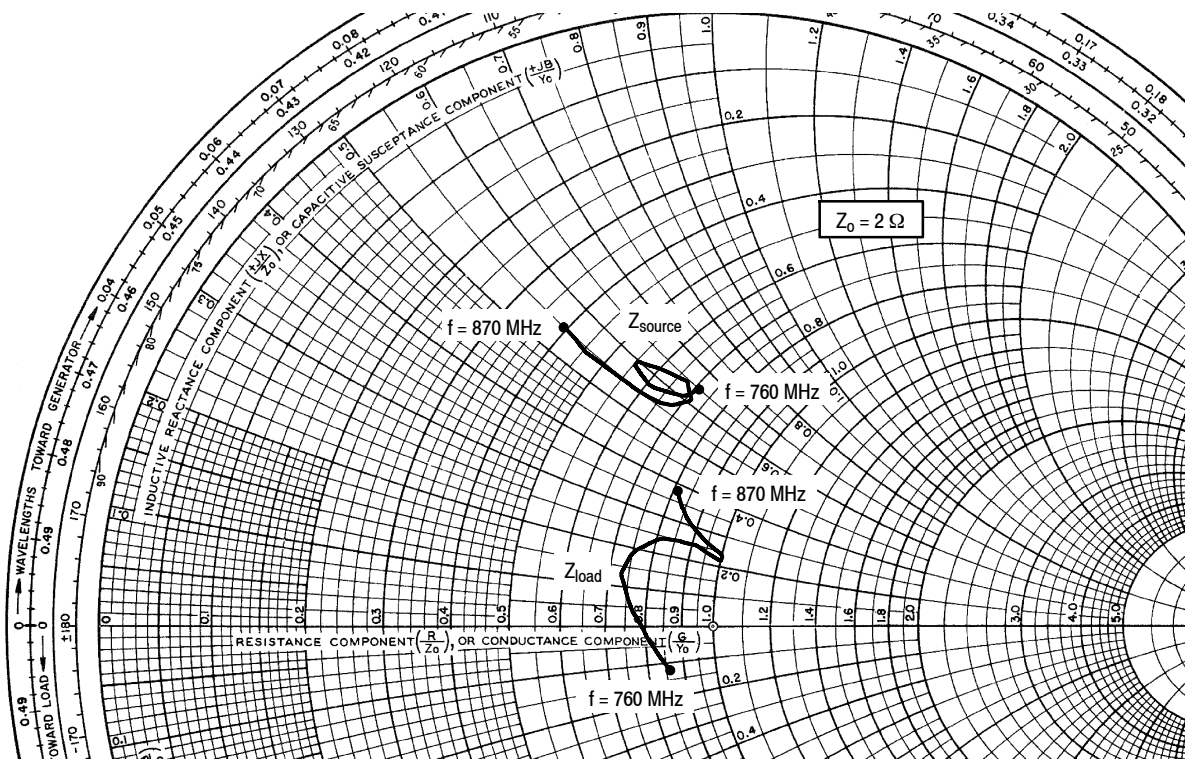


**Figure 18. Output Power versus Gate-Source Voltage**



**Figure 19. Power Gain, Drain Efficiency and Output Power versus Input Power and Frequency**

**760-870 MHz UHF BROADBAND REFERENCE CIRCUIT**

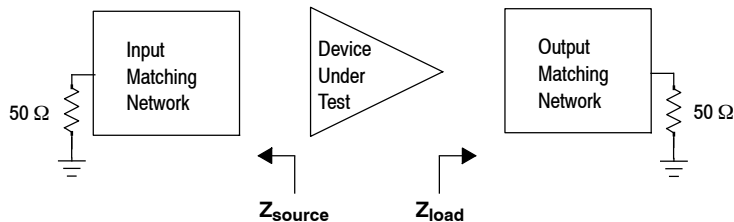


$V_{DD} = 7.5 \text{ Vdc}$ ,  $I_{DQ} = 100 \text{ mA}$ ,  $P_{out} = 6 \text{ W Avg.}$

f MHz	Z <sub>source</sub> Ω	Z <sub>load</sub> Ω
760	1.42 + j1.30	1.72 - j0.24
770	1.37 + j1.21	1.65 - j0.11
780	1.21 + j1.16	1.53 + j0.08
790	1.10 + j1.17	1.46 + j0.25
800	1.09 + j1.19	1.49 + j0.38
810	1.17 + j1.24	1.61 + j0.47
820	1.33 + j1.27	1.82 + j0.50
830	1.42 + j1.22	1.99 + j0.46
840	1.35 + j1.14	1.99 + j0.48
850	1.12 + j1.10	1.84 + j0.56
860	0.90 + j1.08	1.69 + j0.66
870	0.77 + j1.10	1.62 + j0.73

Z<sub>source</sub> = Test circuit impedance as measured from gate to ground.

Z<sub>load</sub> = Test circuit impedance as measured from drain to ground.



**Figure 20. UHF Broadband Series Equivalent Source and Load Impedance — 760-870 MHz**

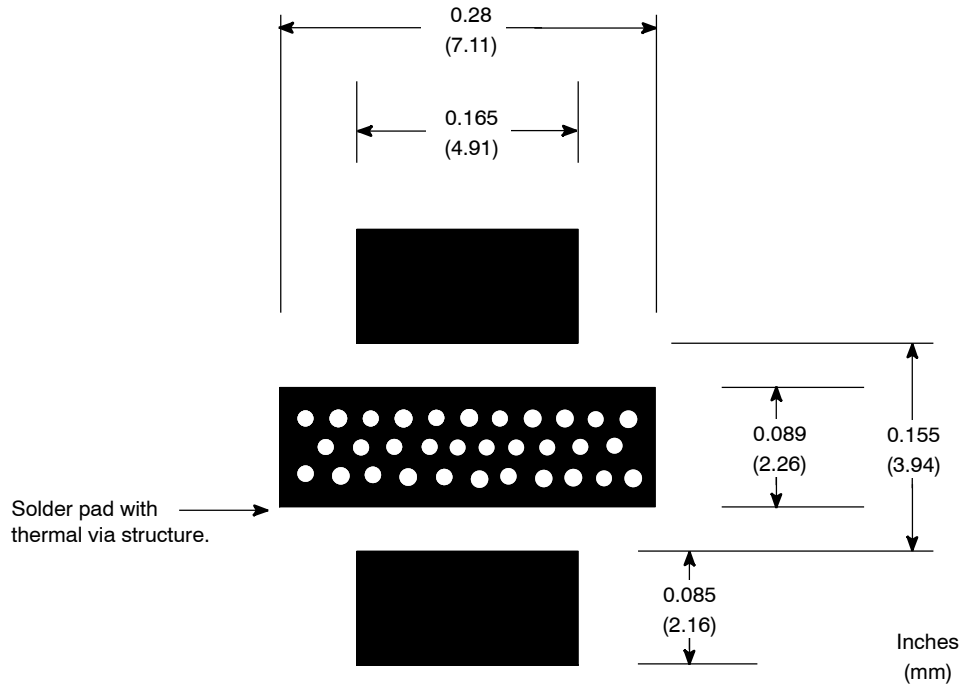


Figure 21. PCB Pad Layout for PLD-1.5W

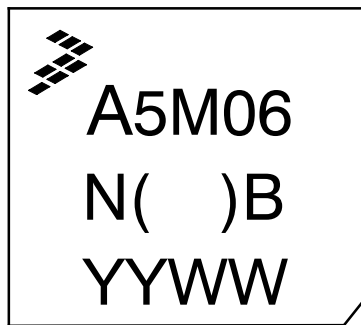
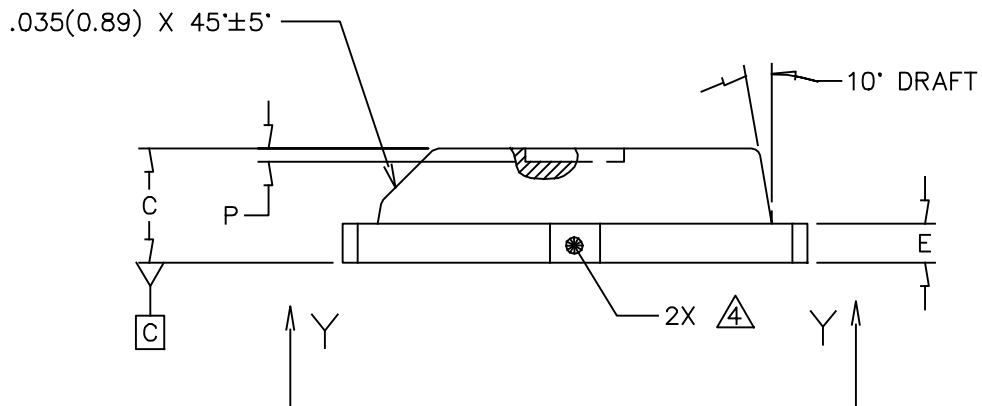
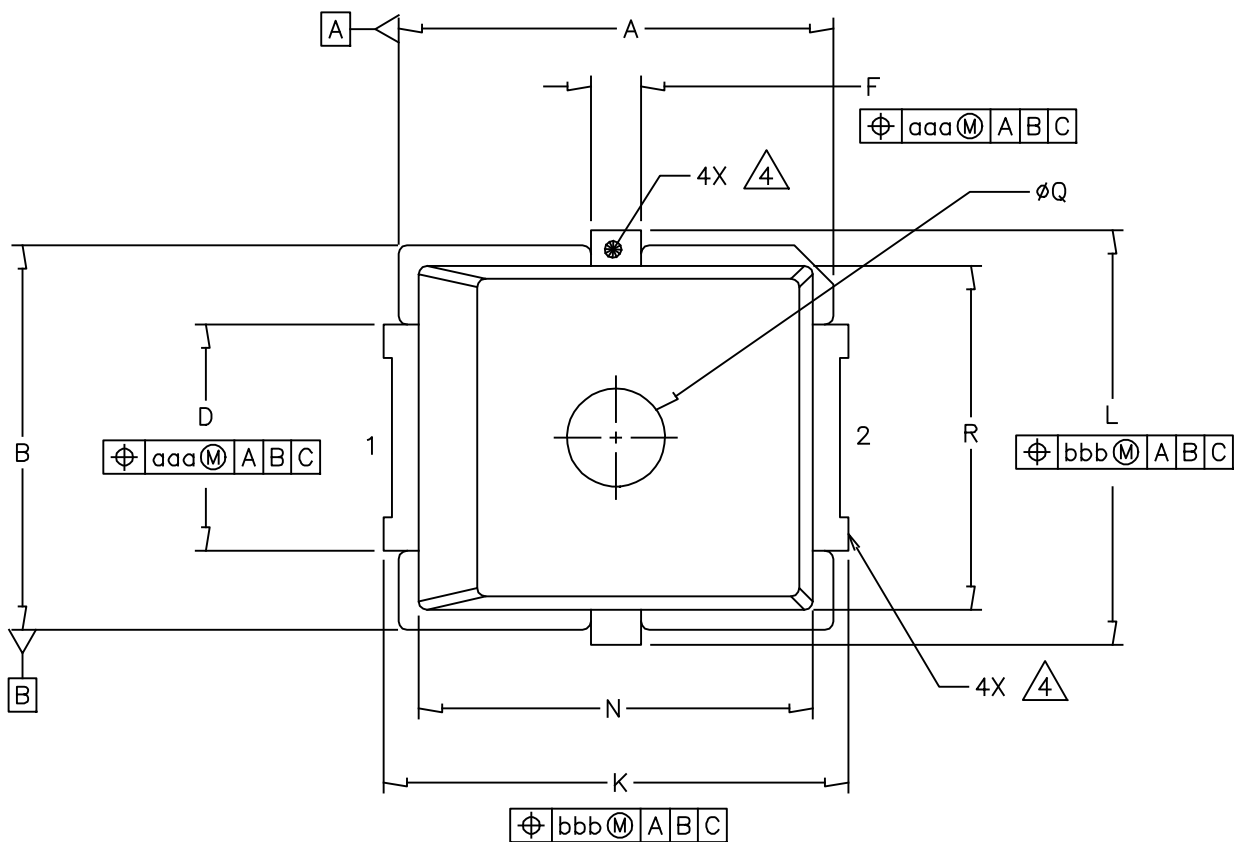
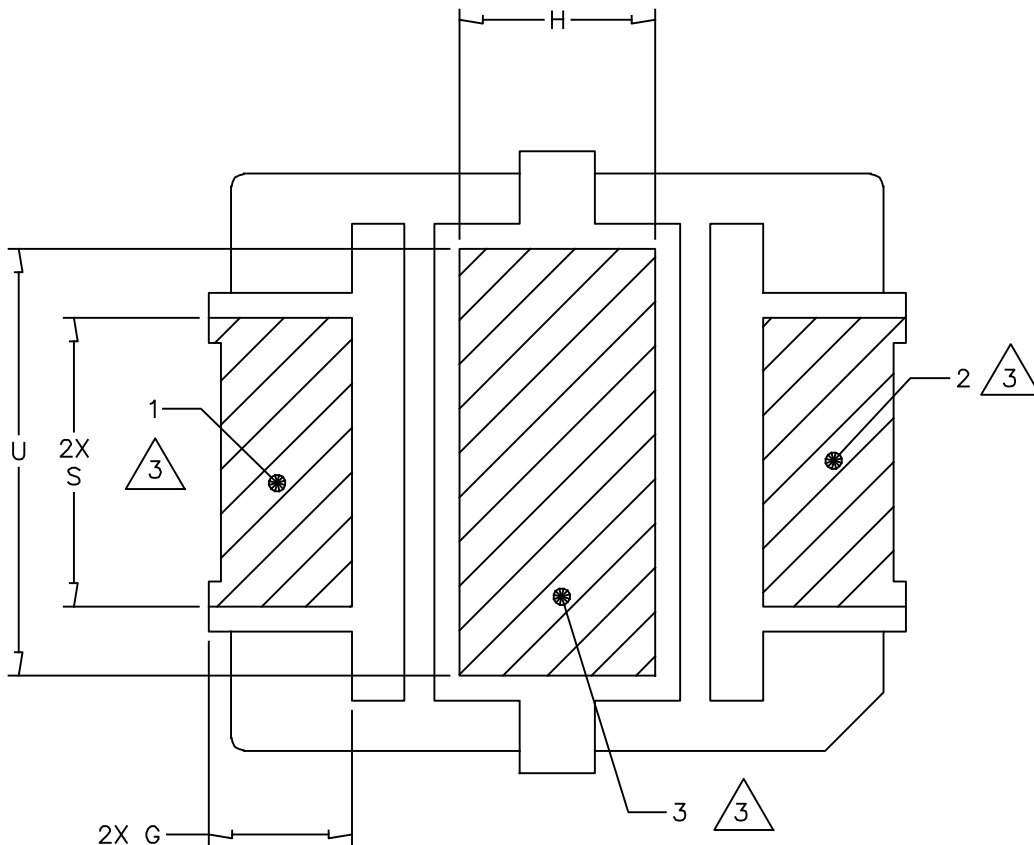


Figure 22. Product Marking

**PACKAGE DIMENSIONS**



<p>© FREESCALE SEMICONDUCTOR, INC. ALL RIGHTS RESERVED.</p>	<p>MECHANICAL OUTLINE</p>	<p>PRINT VERSION NOT TO SCALE</p>	
<p>TITLE:  PLD-1.5W</p>	<p>DOCUMENT NO: 98ASA00476D</p>	<p>REV: 0</p>	
	<p>CASE NUMBER: 2297-01</p>	<p>14 JUN 2012</p>	
	<p>STANDARD: NON-JEDEC</p>		



VIEW Y-Y

© FREESCALE SEMICONDUCTOR, INC. ALL RIGHTS RESERVED.	MECHANICAL OUTLINE	PRINT VERSION NOT TO SCALE	
TITLE:  PLD-1.5W		DOCUMENT NO: 98ASA00476D	REV: 0
		CASE NUMBER: 2297-01	14 JUN 2012
		STANDARD: NON-JEDEC	

NOTES:

1. CONTROLLING DIMENSION: INCH.

2. INTERPRET DIMENSIONS AND TOLERANCES PER ASME Y14.5M-1994.

3. HATCHING REPRESENTS THE EXPOSED AND SOLDERABLE AREA. DIMENSIONS G, S, H AND U REPRESENT THE VALUES BETWEEN THE TWO OPPOSITE POINTS ALONG THE EDGES OF EXPOSED AREA.

4. THESE SURFACES ARE NOT PART OF THE SOLDERABLE SURFACES AND MAY REMAIN UNPLATED.

DIM	INCH		MILLIMETER		DIM	INCH		MILLIMETER	
	MIN	MAX	MIN	MAX		MIN	MAX	MIN	MAX
A	.255	.265	6.48	6.73	Q	.055	.063	1.40	1.60
B	.225	.235	5.72	5.97	R	.200	.210	5.08	5.33
C	.065	.072	1.65	1.83	S	.110	—	2.79	—
D	.130	.150	3.30	3.81	U	.156	—	3.96	—
E	.021	.026	0.53	0.66	aaa		.004		0.10
F	.026	.044	0.66	1.12	bbb		.005		0.13
G	.038	—	0.97	—					
H	.069	—	1.75	—					
J	.160	.180	4.06	4.57					
K	.273	.285	6.93	7.24					
L	.245	.255	6.22	6.48					
N	.230	.240	5.84	6.10					
P	.000	.008	0.00	0.20					
© FREESCALE SEMICONDUCTOR, INC. ALL RIGHTS RESERVED.			MECHANICAL OUTLINE			PRINT VERSION NOT TO SCALE			
TITLE:  PLD-1.5W					DOCUMENT NO: 98ASA00476D			REV: 0	
					CASE NUMBER: 2297-01			14 JUN 2012	
					STANDARD: NON-JEDEC				

## PRODUCT DOCUMENTATION, SOFTWARE AND TOOLS

Refer to the following documents, software and tools to aid your design process.

### Application Notes

- AN1907: Solder Reflow Attach Method for High Power RF Devices in Over-Molded Plastic Packages
- AN1955: Thermal Measurement Methodology of RF Power Amplifiers

### Engineering Bulletins

- EB212: Using Data Sheet Impedances for RF LDMOS Devices

### Software

- Electromigration MTTF Calculator
- RF High Power Model
- .s2p File

### Development Tools

- Printed Circuit Boards

For Software and Tools, do a Part Number search at <http://www.freescale.com>, and select the "Part Number" link. Go to the Software & Tools tab on the part's Product Summary page to download the respective tool.

## REVISION HISTORY

The following table summarizes revisions to this document.

Revision	Date	Description
0	Feb. 2014	• Initial Release of Data Sheet

**How to Reach Us:**

**Home Page:**  
[freescale.com](http://freescale.com)

**Web Support:**  
[freescale.com/support](http://freescale.com/support)

Information in this document is provided solely to enable system and software implementers to use Freescale products. There are no express or implied copyright licenses granted hereunder to design or fabricate any integrated circuits based on the information in this document.

Freescale reserves the right to make changes without further notice to any products herein. Freescale makes no warranty, representation, or guarantee regarding the suitability of its products for any particular purpose, nor does Freescale assume any liability arising out of the application or use of any product or circuit, and specifically disclaims any and all liability, including without limitation consequential or incidental damages. "Typical" parameters that may be provided in Freescale data sheets and/or specifications can and do vary in different applications, and actual performance may vary over time. All operating parameters, including "typicals," must be validated for each customer application by customer's technical experts. Freescale does not convey any license under its patent rights nor the rights of others. Freescale sells products pursuant to standard terms and conditions of sale, which can be found at the following address: [freescale.com/SalesTermsandConditions](http://freescale.com/SalesTermsandConditions).

Freescale and the Freescale logo are trademarks of Freescale Semiconductor, Inc., Reg. U.S. Pat. & Tm. Off. Airfast is a trademark of Freescale Semiconductor, Inc. All other product or service names are the property of their respective owners.

© 2014 Freescale Semiconductor, Inc.

## OUR CERTIFICATE

DiGi provide top-quality products and perfect service for customer worldwide through standardization, technological innovation and continuous improvement. DiGi through third-party certification, we stricly control the quality of products and services. Welcome your RFQ to

Email: [Info@DiGi-Electronics.com](mailto:Info@DiGi-Electronics.com)



Tel: +00 852-30501935

RFQ Email: [Info@DiGi-Electronics.com](mailto:Info@DiGi-Electronics.com)

DiGi is a global authorized distributor of electronic components.