

LPC55S69JBD100Y Datasheet

www.digi-electronics.com

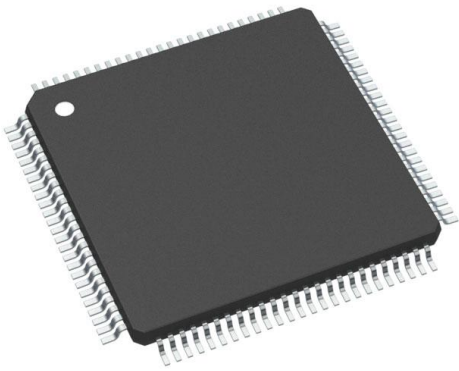

<https://www.DiGi-Electronics.com>

| | |
|------------------------------|---|
| DiGi Electronics Part Number | LPC55S69JBD100Y-DG |
| Manufacturer | NXP USA Inc. |
| Manufacturer Product Number | LPC55S69JBD100Y |
| Description | IC MCU 32BIT 640KB FLSH 100HLQFP |
| Detailed Description | ARM® Cortex®-M33 LPC55S6x Microcontroller IC 32-Bit Single-Core 150MHz 640KB (640K x 8) FLASH 100-HLQFP (14x14) |

This model LPC55S69JBD100Y is available at DiGi Electronics.

DiGi Electronics offers a global database of semiconductor and electronic component datasheets.

We welcome your inquiries regarding pricing, lead time, or other product-related questions.

 [Request a Quote](#)

 [Datasheet Search](#)



Tel: +00 852-30501935

RFQ Email: Info@DiGi-Electronics.com

DiGi is a global authorized distributor of electronic components.

Purchase and inquiry

Manufacturer Product Number:

LPC55569JBD100Y

Series:

LPC5556x

DiGi-Electronics Programmable:

Not Verified

Core Size:

32-Bit Single-Core

Connectivity:

Flexcomm, I2C, MMC/SD/SDIO, SPI, UART/USART, USB

Number of I/O:

64

Program Memory Type:

FLASH

RAM Size:

320K x 8

Data Converters:

A/D 10x16b

Operating Temperature:

-40°C ~ 105°C (TA)

Supplier Device Package:

100-HLQFP (14x14)

Base Product Number:

LPC55569

Manufacturer:

NXP USA Inc.

Product Status:

Active

Core Processor:

ARM® Cortex®-M33

Speed:

150MHz

Peripherals:

Brown-out Detect/Reset, DMA, I2S, POR, PWM, RNG, WDT

Program Memory Size:

640KB (640K x 8)

EEPROM Size:

-

Voltage - Supply (Vcc/Vdd):

1.8V ~ 3.6V

Oscillator Type:

Internal

Mounting Type:

Surface Mount

Package / Case:

100-LQFP Exposed Pad

Environmental & Export classification

RoHS Status:

ROHS3 Compliant

REACH Status:

REACH Unaffected

Moisture Sensitivity Level (MSL):

3 (168 Hours)

LPC55S6x

32-bit Arm Cortex®-M33; M33 coprocessor

Rev. 2.5 — 29 August 2024

Data sheet

1 General description

The LPC55S6x is an ARM Cortex-M33 based microcontroller for embedded applications. These devices include an ARM Cortex-M33 coprocessor, CASPER Crypto/FFT engine, PowerQuad hardware accelerator for DSP functions, up to 320 KB of on-chip SRAM, up to 640 KB on-chip flash, PRINCE module for on-the-fly flash encryption/decryption, high-speed and full-speed USB host and device interface with crystal-less operation for full-speed, SD/MMC/SDIO interface, five general-purpose timers, one SCTimer/PWM, one RTC/alarm timer, one 24-bit Multi-Rate Timer (MRT), a Windowed Watchdog Timer (WWDT), nine flexible serial communication peripherals (which can be configured as a USART, SPI, high speed SPI, I²C, or I²S interface), Programmable Logic Unit (PLU), one 16-bit 1.0 Msamples/sec ADC capable of simultaneous conversions.

The ARM Cortex-M33 provides a security foundation, offering isolation to protect valuable IP and data with TrustZone® technology. It simplifies the design and software development of digital signal control systems with the integrated digital signal processing (DSP) instructions. To support security requirements, the LPC55S6x also offers support for secure boot, HASH, AES, RSA, UUID, DICE, dynamic encrypt and decrypt, debug authentication, and TBSA compliance.

2 Features and benefits

- ARM Cortex-M33 core (CPU0, r0p3):
 - Running at a frequency of up to 150 MHz (device revision 1B only).
 - TrustZone®, Floating Point Unit (FPU) and Memory Protection Unit (MPU).
 - ARM Cortex M33 built-in Nested Vectored Interrupt Controller (NVIC).
 - Non-maskable Interrupt (NMI) input with a selection of sources.
 - Serial Wire Debug with eight breakpoints and four watch points. Includes Serial Wire Output for enhanced debug capabilities.
 - System tick timer.
 - The configuration of this instance includes MPU, FPU, DSP, ETM, and Trustzone.
- ARM Cortex-M33 co-processor (CPU1, r0p3):
 - Running at a CPU frequency of up to 150 MHz (device revision 1B only).
 - The configuration of this instance does not include MPU, FPU, DSP, ETM, and Trustzone.
 - System tick timer.
- CASPER Crypto co-processor is provided to enable hardware acceleration for various functions required for certain asymmetric cryptographic algorithms, such as, Elliptic Curve Cryptography (ECC).
- PowerQuad hardware accelerator for (fixed and floating point unit) CMSIS DSP functions with support of SDK software API faster execution of ARM CMSIS instruction set.
- On-chip memory:
 - Up to 640 KB on-chip flash program memory with flash accelerator and 512 byte page erase and write.
 - Up to 320 KB total SRAM consisting of 32 KB SRAM on Code Bus, 272 KB SRAM on System Bus (272 KB is contiguous), and additional 16 KB USB SRAM on System Bus which can be used by the USB interface or for general purpose use.



- PRINCE module for real-time encryption of data being written to on-chip flash and decryption of encrypted flash data during read to allow asset protection, such as securing application code, and enabling secure flash update.
- On-chip ROM bootloader supports:
 - Booting of images from on-chip flash
 - Supports CRC32 image integrity checking.
 - Supports flash programming through In System Programming (ISP) commands over following interfaces: USB0/1 interfaces using HID Class device, UART interface (Flexcomm 0) with auto baud, SPI slave interfaces (Flexcomm 3 or 9) using mode 3 (CPOL = 1 and CPHA = 1), and I2C slave interface (Flexcomm 1)
 - ROM API functions: Flash programming API, Power control API, and Secure firmware update API using NXP Secure Boot file format, version 2.0 (SB2 files).
 - Supports booting of images from PRINCE encrypted flash regions.
 - Support NXP Debug Authentication Protocol version 1.0 (RSA-2048) and 1.1 (RSA-4096).
 - Supports setting a sealed part to Fault Analysis mode through Debug authentication.
- Secure Boot support:
 - Uses RSASSA-PKCS1-v1_5 signature of SHA256 digest as cryptographic signature verification.
 - Supports RSA-2048 bit public keys (2048 bit modulus, 32-bit exponent).
 - Supports RSA-4096 bit public keys (4096 bit modulus, 32-bit exponent).
 - Uses x509 certificate format to validate image public keys.
 - Supports up to four revocable Root of Trust (RoT) or Certificate Authority keys, Root of Trust establishment by storing the SHA-256 hash digest of the hashes of four RoT public keys in protected flash region (PFR).
 - Supports anti-rollback feature using image key revocation and supports up to 16 Image key certificates revocations using Serial Number field in x509 certificate.
 - Supports Device Identifier Composition Engine (DICE) Specification (version Family 2.0, Level 00 Revision 69) specified by Trusted Computing Group.
- Serial interfaces:
 - Flexcomm Interface contains up to nine serial peripherals (Flexcomm Interface 0-7 and Flexcomm Interface 8). Each Flexcomm Interface (except flexcomm 8, which is dedicated for high-speed SPI) can be selected by software to be a USART, SPI, I²C, and I²S interface. Each Flexcomm Interface includes a FIFO that supports USART, SPI, and I²S. A variety of clocking options are available to each Flexcomm Interface, including a shared fractional baud-rate generator, and time-out feature. Flexcomm interfaces 0 to 7 each provide one channel pair of I²S.
 - I²C-bus interfaces support Fast-mode and Fast-mode Plus with data rates of up to 1Mbit/s and with multiple address recognition and monitor mode. Two sets of true I²C pads also support high-speed Mode (3.4 Mbit/s) as a slave.
 - USB 2.0 full speed host/device controller with on-chip PHY and dedicated DMA controller supporting crystal-less operation in device mode using software library example in technical note (TN00063).
 - USB 2.0 high-speed host/device controller with on-chip high-speed PHY.
- Digital peripherals:
 - DMA0 controller with 23 channels and up to 22 programmable triggers, able to access all memories and DMA-capable peripherals.
 - DMA1 controller with 10 channels and up to 15 programmable triggers, able to access all memories and DMA-capable peripherals.
 - Secured digital input/output (SD/MMC and SDIO) card interface with DMA support. SDIO with support for up to two cards. Supported card types are MMC, SDIO, and CE-ATA. Supports SD2.0, and SDR25 (52MHz).
 - CRC engine block can calculate a CRC on supplied data using one of three standard polynomials with DMA support.
 - Up to 64 General-Purpose Input/Output (GPIO) pins.
 - GPIO registers are located on the AHB for fast access. The DMA supports GPIO ports.

- Up to eight GPIOs can be selected as pin interrupts (PINT), triggered by rising, falling or both input edges.
- Two GPIO grouped interrupts (GINT) enable an interrupt based on a logical (AND/OR) combination of input states.
- I/O pin configuration with support for up to 16 function options.
- Programmable Logic Unit (PLU) to create small combinatorial and/or sequential logic networks including state machines.
- Security Features:
 - ARM TrustZone® enabled.
 - AES-256 encryption/decryption engine with keys fed directly from PUF or a software supplied key
 - Secure Hash Algorithm (SHA2) module supports secure boot with dedicated DMA controller.
 - Physical Unclonable Function (PUF) using dedicated SRAM for silicon fingerprint. PUF can generate, store, and reconstruct key sizes from 64 to 4096 bits. Includes hardware for key extraction.
 - True Random Number Generator (TRNG).
 - 128 bit unique device serial number for identification (UUID).
 - Secure GPIO.
- Timers:
 - Five 32-bit standard general purpose asynchronous timers/counters, which support up to four capture inputs and four compare outputs, PWM mode, and external count input. Specific timer events can be selected to generate DMA requests.
 - One SCTimer/PWM with 8 input and 10 output functions (including 16 capture and match registers). Inputs and outputs can be routed to or from external pins and internally to or from selected peripherals. Internally, the SCTimer/PWM supports 16 captures/matches, 16 events, and 32 states.
 - 32-bit Real-time clock (RTC) with 1 s resolution running in the always-on power domain. Another timer in the RTC can be used for wake-up from all low power modes including deep power-down, with 1 ms resolution. The RTC is clocked by the 32 kHz FRO or 32.768 kHz external crystal.
 - Multiple-channel multi-rate 24-bit timer (MRT) for repetitive interrupt generation at up to four programmable, fixed rates.
 - Windowed Watchdog Timer (WWDT) with FRO 1 MHz as clock source.
 - The Micro-Tick Timer running from the watchdog oscillator can be used to wake-up the device from sleep and deep-sleep modes. Includes 4 capture registers with pin inputs.
 - 42-bit free running OS Timer as continuous time-base for the system, available in any reduced power modes. It runs on 32kHz clock source, allowing a count period of more than 4 years.
- Analog peripherals:
 - 16-bit ADC with five differential channel pair (or 10 single-ended channels), and with multiple internal and external trigger inputs and sample rates of up to 1.0 MSamples/sec. The ADC supports simultaneous conversions, on two ADC input channels belonging to a differential pair.
 - Integrated temperature sensor connected to the ADC.
 - Comparator with five input pins and external or internal reference voltage.
- Clock generation:
 - Internal Free Running Oscillator (FRO). This oscillator provides a selectable 96 MHz output, and a 12 MHz output (divided down from the selected higher frequency) that can be used as a system clock. The FRO is trimmed to +/- 2% accuracy over the entire voltage and -40 C to 105 C. For devices with date code 2041 (yyww) and onwards, the FRO is trimmed to +/- 1% accuracy over the entire voltage and 0 C to 85 C.
 - 32 kHz Internal Free Running Oscillator FRO. The FRO is trimmed to +/- 2% accuracy over the entire voltage and temperature range.
 - Internal low power oscillator (FRO 1 MHz) trimmed to +/- 15% accuracy over the entire voltage and temperature range.

- Crystal oscillator with an operating frequency of 16 MHz to 32 MHz. Option for external clock input (bypass mode) for clock frequencies of up to 25 MHz.
- Crystal oscillator with 32.768 KHz operating frequency. Option for external clock input (bypass mode) for clock frequencies of up to 100 kHz.
- PLL0 and PLL1 allows CPU operation up to the maximum CPU rate without the need for a high-frequency external clock. PLL0 and PLL1 can run from the internal FRO 12 MHz output, the external oscillator, internal FRO 1 MHz output, or the 32.768 KHz RTC oscillator.
- Clock output function with divider to monitor internal clocks.
- Frequency measurement unit for measuring the frequency of any on-chip or off-chip clock signal.
- Each crystal oscillator has one embedded capacitor bank which can be used as an integrated load capacitor. Using APIs, the capacitor banks on each crystal pin can tune the frequency for crystals with a Capacitive Load (CL) which conserves board space and reduces costs.
- Power-saving modes and wake-up:
 - Integrated PMU (Power Management Unit) to minimize power consumption.
 - Reduced power modes: Sleep, deep-sleep with RAM retention, power-down with RAM retention and CPU0 retention, and deep power-down with RAM retention.
 - Configurable wake-up options from peripherals interrupts.
 - The Micro-Tick Timer running from the watchdog oscillator, and the Real-Time Clock (RTC) running from the 32.768 kHz clock, can be used to wake-up the device from sleep and deep-sleep modes.
 - Power-On Reset (POR, around 0.8 V).
 - Brown-Out Detectors (BOD) for VBAT_DCDC for forced reset or interrupt.
- Operating from internal DC-DC converter.
- Single power supply 1.8 V to 3.6 V.
- JTAG boundary scan supported.
- Operating temperature range -40 °C to +105 °C.
- Available in HLQFP100, HTQFP64, VFBGA98, and VFBGA59 packages.

3 Ordering information

Table 1. Ordering information

| Type number | Package | | Version |
|----------------|----------|--|-----------|
| | Name | Description | |
| LPC55S66JBD100 | HLQFP100 | plastic low profile quad flat package; 100 leads; body 14 × 14 × 0.5mm pitch | SOT1570-3 |
| LPC55S69JBD100 | HLQFP100 | plastic low profile quad flat package; 100 leads; body 14 × 14 × 0.5mm pitch | SOT1570-3 |
| LPC55S66JEV98 | VFBGA98 | thin fine-pitch ball grid array package; 98 balls; body 7' 7' 0.5 mm | SOT1982-1 |
| LPC55S69JEV98 | VFBGA98 | thin fine-pitch ball grid array package; 98 balls; body 7' 7' 0.5 mm | SOT1982-1 |
| LPC55S66JBD64 | HTQFP64 | plastic low profile quad flat package; 64 leads; body 10 x10 x 0.5mm pitch | SOT855-5 |
| LPC55S69JBD64 | HTQFP64 | plastic low profile quad flat package; 64 leads; body 10 x10 x 0.5mm pitch | SOT855-5 |
| LPC55S69JEV59 | VFBGA59 | Thin fine-pitch ball grid array package; 59 balls; body 4 × 4 × 0.4 mm pitch | SOT2162-1 |
| LPC55S66JEV59 | VFBGA59 | Thin fine-pitch ball grid array package; 59 balls; body 4 × 4 × 0.4 mm pitch | SOT2162-1 |

3.1 Ordering options

Table 2. Ordering options

| Type number | Max CPU Frequency (MHz) | Primary core (CPU0) | Secondary core (CPU1) | Power Quad | CASPER | Flash/KB | Total SRAM/KB | Secure boot | TrustZone | PRINCE | PUF Controller | HASH-AES | SDIO | USB | GPIO |
|----------------|-------------------------|---------------------|-----------------------|------------|--------|----------|---------------|-------------|-----------|--------|----------------|----------|------|---------|------|
| LPC55S66JBD100 | 150 ^[1] | yes | yes | yes | yes | 256 | 144 | yes | yes | yes | yes | yes | yes | FS + HS | 64 |
| LPC55S69JBD100 | 150 ^[1] | yes | yes | yes | yes | 640 | 320 | yes | yes | yes | yes | yes | yes | FS + HS | 64 |
| LPC55S66JEV98 | 150 ^[1] | yes | yes | yes | yes | 256 | 144 | yes | yes | yes | yes | yes | yes | FS + HS | 64 |
| LPC55S69JEV98 | 150 ^[1] | yes | yes | yes | yes | 640 | 320 | yes | yes | yes | yes | yes | yes | FS + HS | 64 |
| LPC55S66JBD64 | 150 ^[1] | yes | yes | yes | yes | 256 | 144 | yes | yes | yes | yes | yes | yes | FS + HS | 36 |
| LPC55S69JBD64 | 150 ^[1] | yes | yes | yes | yes | 640 | 320 | yes | yes | yes | yes | yes | yes | FS + HS | 36 |
| LPC55S69JEV59 | 150 ^[1] | yes | yes | yes | yes | 640 | 320 | yes | yes | yes | yes | yes | yes | HS | 37 |
| LPC55S66JEV59 | 150 ^[1] | yes | yes | yes | yes | 256 | 144 | yes | yes | yes | yes | yes | yes | HS | 37 |

[1] Device revision 1B operates at a maximum CPU frequency of up to 150 MHz. Device revision 0A operates at a maximum CPU frequency of up to 100 MHz.

4 Marking

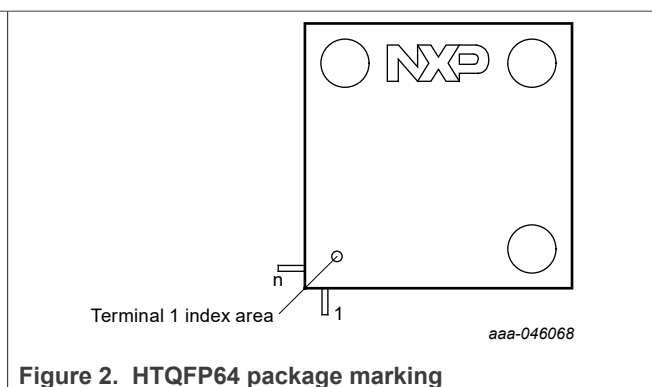
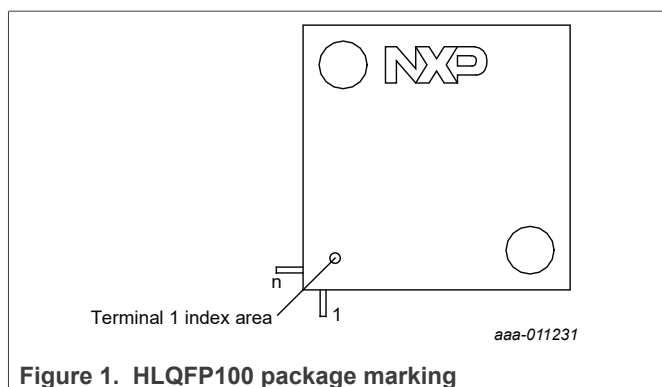

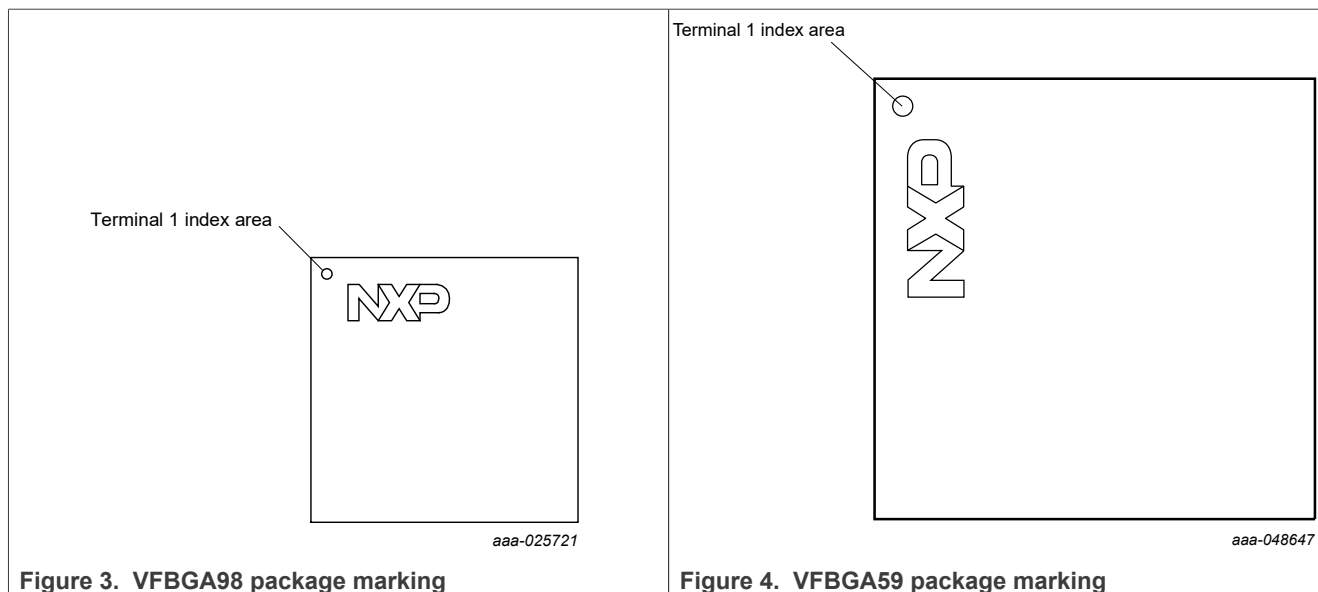

The LPC55S6x HLQFP100 package has the following top-side marking:

- First line: LPC55S6xJBD100
- Second line: xxxxxxxx
- Third line: zzyywwxR
 - yyww: Date code with yy = year and ww = week.
 - xR: Device revision 0A or Device revision 1B

The LPC55S6x HTQFP64 package has the following top-side marking:

- First line: LPC55S6x
- Second line: JBD64
- Third line: xxxx
- Fourth line: xxxx
- Fifth line: zzyywwxR
 - yyww: Date code with yy = year and ww = week.
 - xR: Device revision 1B

The LPC55S6x VFBGA98 package has the following top-side marking:

- First line: LPC55S6x
- Second line: JEV98
- Third line: xxxxxxxx
- Fourth line: zzyywwxR
 - yyww: Date code with yy = year and ww = week.
 - xR: Device revision 1B

The LPC55S69 and LPC55S66 VFBGA59 package has the following top-side marking:

- First line: S69 or S66
- Second line: xxxx
- Third line: zzywwxR
 - yyw: Date code with y = year and ww = week.
 - xR: Device revision 1B

5 Block diagram

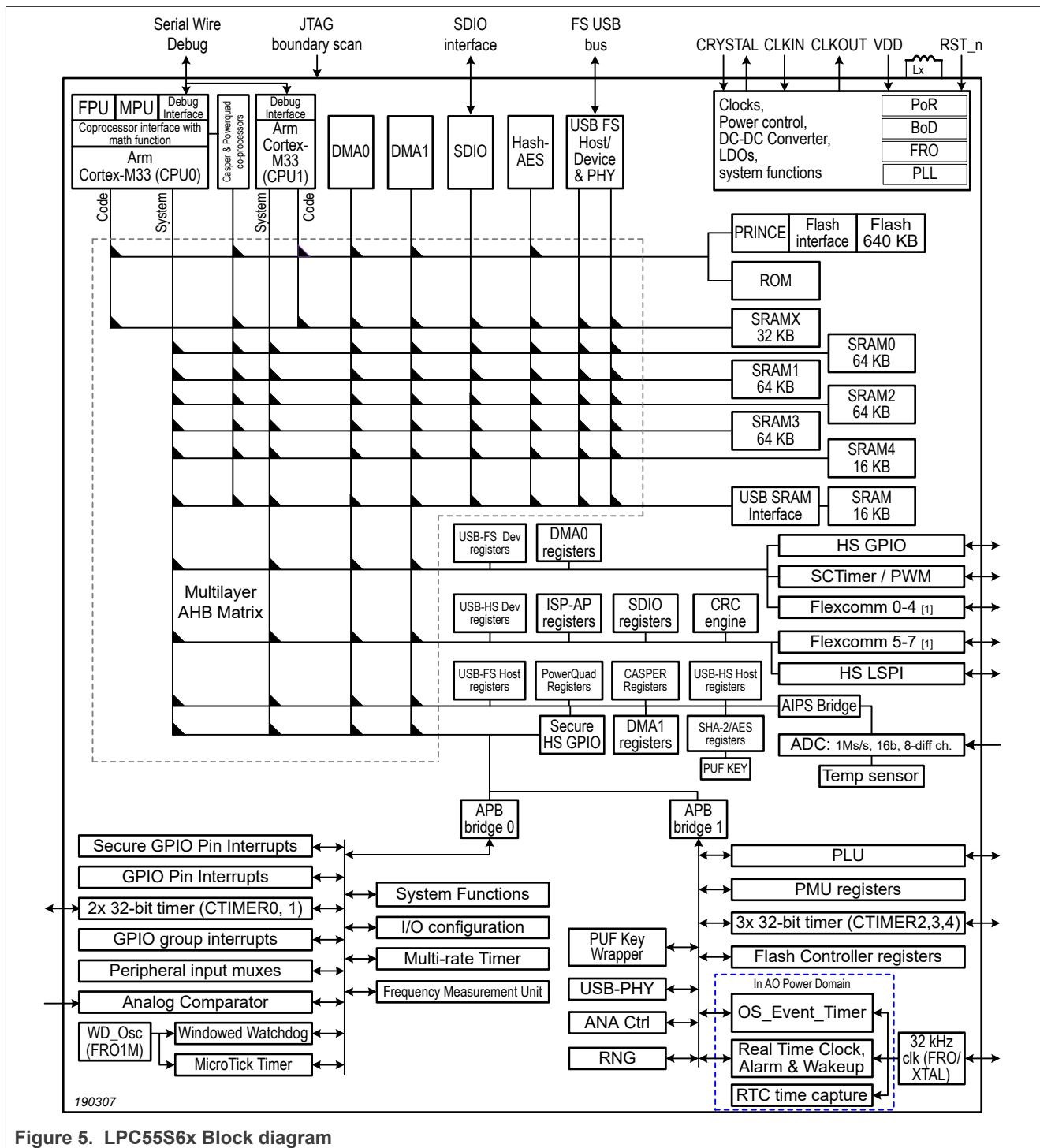

Figure 5. LPC55S6x Block diagram

6 Pinning information

6.1 Pin description

Table 4 shows the pin functions available on each pin, and for each package. These functions are selectable using the IOCON control registers.

Some functions, such as ADC or comparator inputs, are available only on specific pins when digital functions are disabled on those pins. By default, the GPIO function is selected except on pins PIO0_11 and PIO0_12, which are the serial wire debug pins. This allows debug to operate through reset.

All pins have all pull-ups, pull-downs, and inputs turned off at reset except PIO0_2, PIO0_5, PIO0_11, PIO0_12, PIO0_13 and PIO0_14 pins. This prevents power loss through pins prior to software configuration. Due to special pin functions, some pins have a different reset configuration. PIO0_5 and PIO0_12 pins have internal pull-up enabled by default, and PIO0_2 and PIO0_11 have internal pull-down enabled by default. PIO0_13 and PIO0_14 are true open drain pins. Refer to pin description table for default reset configuration.

The state of port pin PIO0_5 at Reset determines the boot source of the part or if the handler is invoked.

The external reset pin or 3 wake-up pins can trigger a wake-up from deep power-down mode. For the wake-up pins, do not assign any function to this pin if it will be used as a wake-up input when using deep power-down mode. If not in deep power-down mode, a function can be assigned to this pin. If the pin is used for wake-up, it should be pulled HIGH externally before entering deep power-down mode. A LOW-going pulse as short as 50 ns causes the chip to exit deep power-down mode wakes up the part.

The JTAG functions TRST, TCK, TMS, TDI, and TDO, are selected on pins PIO0_2 to PIO0_6 by hardware when the part is in boundary scan mode. The JTAG functions cannot be used for debug mode.

Table 3. Pin description

| Symbol | 59 pin VFBGA | 64 pin HTQFP | 98 pin VFBGA | 100 pin HLQFP | | Reset state [1] | Type | Function # | Description |
|--------------------|--------------|--------------|--------------|---------------|-----|-----------------|------------|------------|--|
| PIO0_0/ ACMP0_A | J8 | 36 | L12 | 54 | [2] | Z | I/O; AI | 0 | PIO0_0/ACMP0_A General-purpose digital input/output pin. Comparator 0, input A if the DIGIMODE bit is set to 0 and ANAMODE is set to 1 in the IOCON register for this pin. |
| | | | | | | | | 1 | R Reserved. |
| | | | | | | | I/O | 2 | FC3_SCK Flexcomm 3: USART, SPI, or I2S clock. |
| | | | | | | | O | 3 | CTIMER0_MAT0 32-bit CTimer0 match output 0. |
| | | | | | | | I | 4 | SCT0_GPIO Pin input 0 to SCTimer/PWM. |
| | | | | | | | | 5 | R Reserved. |
| | | | | | | | I | 6 | SD1_CARD_INT_N SD/MMC 1 card interrupt. |
| | | | | | | | | 7 | R Reserved. |

Table 3. Pin description...continued

| Symbol | 59 pin VFBGA | 64 pin HTQFP | 98 pin VFBGA | 100 pin HLQFP | | Reset state [1] | Type | Function # | Description |
|-----------------|--------------|--------------|--------------|---------------|--------|-----------------|------|------------|--|
| | | | | | | | | 8 | R Reserved. |
| | | | | | | | | 9 | R Reserved. |
| | | | | | | | I/O | 10 | SEC_PIO0_0 Secure GPIO pin. |
| PIO0_1 | A1 | 2 | F5 | 7 | [3] | Z | I/O | 0 | PIO0_1 General-purpose digital input/output pin. |
| | | | | | | | | 1 | R Reserved. |
| | | | | | | | I/O | 2 | FC3_CTS_SDA_SSEL0 Flexcomm 3: USART clear-to-send, I2C data I/O, SPI Slave Select 0. |
| | | | | | | | I | 3 | CTIMER_INP0 Capture input to CTIMER input muxes. |
| | | | | | | | I | 4 | SCT0_GPI1 Pin input 1 to SCTimer/PWM. |
| | | | | | | | | 5 | R Reserved. |
| | | | | | | | O | 6 | SD1_CLK SD/MMC 1 card clock. |
| | | | | | | | O | 7 | CMP0_OUT Analog comparator 0 output. |
| | | | | | | | | 8 | R Reserved. |
| | | | | | | | | 9 | R Reserved. |
| | | | | | | | I/O | 10 | SEC_PIO0_1 Secure GPIO pin. |
| PIO0_2/ TRST | B7 | 52 | B11 | 81 | [3][4] | PD | I/O | 0 | PIO0_2 General-purpose digital input/output pin. In boundary scan mode: TRST (Test Reset). Remark: In ISP mode, this pin is set to the Flexcomm 3 SPI MISO function. |
| | | | | | | | I/O | 1 | FC3_TXD_SCL_MISO_WS Flexcomm 3: USART transmitter, I2C clock, SPI master-in/slave-out data I/O, I2S word-select/frame. |
| | | | | | | | I | 2 | CTIMER_INP1 Capture input to CTIMER input multiplexers. |
| | | | | | | | O | 3 | SCT0_OUT0 |

Table 3. Pin description...continued

| Symbol | 59 pin VFBGA | 64 pin HTQFP | 98 pin VFBGA | 100 pin HLQFP | | Reset state ^[1] | Type | Function # | Description |
|----------------|--------------|--------------|--------------|---------------|--------|----------------------------|------|------------|--|
| | | | | | | | | | SCTimer/PWM output 0. |
| | | | | | | | I | 4 | SCT0_GPI2 Pin input 2 to SCTimer/PWM. |
| | | | | | | | | 5 | R Reserved. |
| | | | | | | | | 6 | R Reserved. |
| | | | | | | | | 7 | R Reserved. |
| | | | | | | | | 8 | R Reserved. |
| | | | | | | | | 9 | R Reserved. |
| | | | | | | | I/O | 10 | SEC_PIO0_2 Secure GPIO pin. |
| PIO0_3/ TCK | B6 | 53 | F8 | 83 | [3][4] | Z | I/O | 0 | PIO0_3 General-purpose digital input/output pin. In boundary scan mode: TCK (Test Clock In). Remark: In ISP mode, this pin is set to the Flexcomm 3 SPI MOSI function. |
| | | | | | | | I/O | 1 | FC3_RXD_SDA_MOSI_DATA Flexcomm 3: USART receiver, I2C data I/O, SPI master-out/slave-in data, I2S data I/O. |
| | | | | | | | O | 2 | CTIMER0_MAT1 32-bit CTimer0 match output 1. |
| | | | | | | | O | 3 | SCT0_OUT1 SCTimer/PWM output 1. |
| | | | | | | | I | 4 | SCT0_GPI3 Pin input 3 to SCTimer/PWM. |
| | | | | | | | | 5 | R Reserved. |
| | | | | | | | | 6 | R Reserved. |
| | | | | | | | | 7 | R Reserved. |
| | | | | | | | | 8 | R Reserved. |
| | | | | | | | | 9 | R Reserved. |
| | | | | | | | I/O | 10 | SEC_PIO0_3 Secure GPIO pin. |

Table 3. Pin description...continued

| Symbol | 59 pin VFBGA | 64 pin HTQFP | 98 pin VFBGA | 100 pin HLQFP | | Reset state [1] | Type | Function # | Description |
|----------------|---|--------------|--------------|---------------|--------|-----------------|------|------------|--|
| PIO0_4/ TMS | A6 | 55 | E7 | 86 | [3][4] | Z | I/O | 0 | PIO0_4 General-purpose digital input/output pin. In boundary scan mode: TMS (Test Mode Select). Remark: In ISP mode, this pin is set to the Flexcomm 3 SPI SSEL0 function. |
| | | | | | | | | 1 | R Reserved. |
| | | | | | | | | I/O 2 | FC4_SCK Flexcomm 4: USART, SPI, or I2S clock. |
| | | | | | | | | I 3 | CTIMER_INP12 Capture input to CTIMER input multiplexers. |
| | | | | | | | | I 4 | SCT0_GPI4 Pin input 4 to SCTimer/PWM. |
| | | | | | | | | 5 | R Reserved. |
| | | | | | | | | 6 | R Reserved. |
| | | | | | | | | 7 | R Reserved. |
| | | | | | | | | I/O 8 | FC3_CTS_SDA_SSEL0 Flexcomm 3: USART clear-to-send, I2C data I/O, SPI Slave Select 0. |
| | | | | | | | | 9 | R Reserved. |
| I/O 10 | SEC_PIO0_4 Secure GPIO pin. | | | | | | | | |
| PIO0_5/ TDI | C6 | 56 | A7 | 88 | [3][4] | PU | I/O | 0 | PIO0_5 General-purpose digital input/output pin. In boundary scan mode: TDI (Test Data In). Remark: The state of this pin at Reset determines the boot source for the part or if ISP handler is invoked. See the Boot Process chapter in UM11126 for more details. |
| | | | | | | | | 1 | R Reserved. |
| | | | | | | | | I/O 2 | FC4_RXD_SDA_MOSI_DATA Flexcomm 4: USART receiver, I2C data I/O, SPI master-out/slave-in data, I2S data I/O. |
| O 3 | CTIMER3_MAT0 32-bit CTimer3 match output 0. | | | | | | | | |

Table 3. Pin description...continued

| Symbol | 59 pin VFBGA | 64 pin HTQFP | 98 pin VFBGA | 100 pin HLQFP | | Reset state ^[1] | Type | Function # | Description |
|----------------|--------------|--------------|--------------|---------------|--------|----------------------------|------|------------|---|
| | | | | | | | I | 4 | SCT0_GPI5 Pin input 5 to SCTimer/PWM. |
| | | | | | | | | 5 | R Reserved. |
| | | | | | | | | 6 | R Reserved. |
| | | | | | | | | 7 | R Reserved. |
| | | | | | | | I/O | 8 | FC3_RTS_SCL_SSEL1 Flexcomm 3: USART request-to-send, I2C clock, SPI slave select 1. |
| | | | | | | | I/O | 9 | MCLK MCLK input or output for I2S. |
| | | | | | | | I/O | 10 | SEC_PIO0_5 Secure GPIO pin. |
| PIO0_6/ TDO | C5 | 57 | B7 | 89 | [3][4] | Z | I/O | 0 | PIO0_6 General-purpose digital input/output pin. In boundary scan mode: TDO (Test Data Out). Remark: In ISP mode, this pin is set to the Flexcomm 3 SPI SCK function. |
| | | | | | | | I/O | 1 | FC3_SCK Flexcomm 3: USART, SPI, or I2S clock. |
| | | | | | | | I | 2 | CTIMER_INP13 Capture input to CTIMER input multiplexers. |
| | | | | | | | O | 3 | CTIMER4_MAT0 32-bit CTimer4 match output 0. |
| | | | | | | | I | 4 | SCT0_GPI6 Pin input 6 to SCTimer/PWM. |
| | | | | | | | | 5 | R Reserved. |
| | | | | | | | | 6 | R Reserved. |
| | | | | | | | | 7 | R Reserved. |
| | | | | | | | | 8 | R Reserved. |
| | | | | | | | | 9 | R Reserved. |
| | | | | | | | I/O | 10 | SEC_PIO0_6 Secure GPIO pin. |

Table 3. Pin description...continued

| Symbol | 59 pin VFBGA | 64 pin HTQFP | 98 pin VFBGA | 100 pin HLQFP | | Reset state [1] | Type | Function # | Description |
|--------|--------------|-----------------------|---------------------------------------|---------------|-----|-----------------|------|------------|---|
| PIO0_7 | A2 | 1 | G5 | 6 | [3] | Z | I/O | 0 | PIO0_7 General-purpose digital input/output pin. |
| | | | | | | | I/O | 1 | FC3_RTS_SCL_SSEL1 Flexcomm 3: USART request-to-send, I2C clock, SPI slave select 1. |
| | | | | | | | O | 2 | SD0_CLK SD/MMC 0 card clock. |
| | | | | | | | I/O | 3 | FC5_SCK Flexcomm 5: USART, SPI, or I2S clock. |
| | | | | | | | I/O | 4 | FC1_SCK Flexcomm 1: USART, SPI, or I2S clock. |
| | | | | | | | | 5 | R Reserved. |
| | | | | | | | | 6 | R Reserved. |
| | | | | | | | | 7 | R Reserved. |
| | | | | | | | | 8 | R Reserved. |
| | | | | | | | | 9 | R Reserved. |
| | I/O | 10 | SEC_PIO0_7 Secure GPIO pin. | | | | | | |
| PIO0_8 | H1 | 17 | M2 | 26 | [3] | Z | I/O | 0 | PIO0_8 General-purpose digital input/output pin. |
| | | | | | | | I/O | 1 | FC3_SSEL3 Flexcomm 3: SPI slave select 3. |
| | | | | | | | I/O | 2 | SD0_CMD SD/MMC 0 card command I/O. |
| | | | | | | | I/O | 3 | FC5_RXD_SDA_MOSI_DATA Flexcomm 5: USART receiver, I2C data I/O, SPI master-out/slave-in data, I2S data I/O. |
| | | | | | | | O | 4 | SWO Serial Wire Debug trace output. |
| | | | | | | | | 5 | R Reserved. |
| | | | | | | | | 6 | R Reserved. |
| | 7 | R Reserved. | | | | | | | |

Table 3. Pin description...continued

| Symbol | 59 pin VFBGA | 64 pin HTQFP | 98 pin VFBGA | 100 pin HLQFP | | Reset state [1] | Type | Function # | Description |
|--------------------|--------------|--------------|--------------|---------------|-----|-----------------|---------|------------|---|
| | | | | | | | | 8 | R Reserved. |
| | | | | | | | | 9 | R Reserved. |
| | | | | | | | I/O | 10 | SEC_PIO0_8 Secure GPIO pin. |
| PIO0_9/ ACMP0_B | J9 | 37 | L13 | 55 | [2] | Z | I/O; AI | 0 | PIO0_9/ACMP0_B General-purpose digital input/output pin. Comparator 0, input B if the DIGIMODE bit is set to 0 and ANAMODE is set to 1 in the IOCON register for this pin. |
| | | | | | | | I/O | 1 | FC3_SSEL2 Flexcomm 3: SPI slave select 2. |
| | | | | | | | O | 2 | SD0_POW_EN SD/MMC 0 card power enable. |
| | | | | | | | I/O | 3 | FC5_TXD_SCL_MISO_WS Flexcomm 5: USART transmitter, I2C clock, SPI master-in/slave-out data I/O, I2S word-select/frame. |
| | | | | | | | | 4 | R Reserved. |
| | | | | | | | | 5 | R Reserved. |
| | | | | | | | | 6 | R Reserved. |
| | | | | | | | | 7 | R Reserved. |
| | | | | | | | | 8 | R Reserved. |
| | | | | | | | | 9 | R Reserved. |
| | | | | | | | I/O | 10 | SEC_PIO0_9 Secure GPIO pin. |
| PIO0_10/ ADC0_1 | F1 | 13 | F2 | 21 | [2] | Z | I/O; AI | 0 | PIO0_10/ADC0_1 General-purpose digital input/output pin. ADC single ended input channel 1A - CH1A. Can optionally be paired with CH1B as the positive differential input on ADC1 channel 1. |
| | | | | | | | I/O | 1 | FC6_SCK Flexcomm 6: USART, SPI, or I2S clock. |
| | | | | | | | I | 2 | CTIMER_INP10 |

Table 3. Pin description...continued

| Symbol | 59 pin VFBGA | 64 pin HTQFP | 98 pin VFBGA | 100 pin HLQFP | Reset state [1] | Type | Function # | Description |
|--------------------|--------------|--------------|--------------|---------------|-----------------|------|------------|---|
| | | | | | | | | Capture input to CTIMER input multiplexers. |
| | | | | | | O | 3 | CTIMER2_MAT0 32-bit CTimer2 match output 0. |
| | | | | | | I/O | 4 | FC1_TXD_SCL_MISO_WS Flexcomm 1: USART transmitter, I2C clock, SPI master-in/slave-out data I/O, I2S word-select/frame. |
| | | | | | | O | 5 | SCT0_OUT2 SCTimer/PWM output 2. |
| | | | | | | O | 6 | SWO Serial Wire Debug trace output. |
| | | | | | | | 7 | R Reserved. |
| | | | | | | | 8 | R Reserved. |
| | | | | | | | 9 | R Reserved. |
| | | | | | | I/O | 10 | SEC_GPIO0_10 Secure GPIO pin. |
| PIO0_11/ ADC0_9 | D2 | 6 | F1 | 13 | [2] | PD | I/O; AI | PIO0_11/ADC0_9 General-purpose digital input/output pin. ADC single ended input channel 1B - CH1B. Can optionally be paired with CH1A as the negative differential input on ADC1 channel 1. |
| | | | | | | | I/O | FC6_RXD_SDA_MOSI_DATA Flexcomm 6: USART receiver, I2C data I/O, SPI master-out/slave-in data, I2S data I/O. |
| | | | | | | O | 2 | CTIMER2_MAT2 32-bit CTimer2 match output 2. |
| | | | | | | I | 3 | FREQME_GPIO_CLK_A Frequency Measure pin clock input A. |
| | | | | | | | 4 | R Reserved. |
| | | | | | | | 5 | R Reserved. |
| | | | | | | I | 6 | SWCLK Serial Wire Debug clock. This is the default function after booting. |
| | | | | | | | 7 | R Reserved. |

Table 3. Pin description...continued

| Symbol | 59 pin VFBGA | 64 pin HTQFP | 98 pin VFBGA | 100 pin HLQFP | | Reset state [1] | Type | Function # | Description |
|---------------------|--------------|--------------|--------------|---------------|-----|-----------------|---------|------------|--|
| | | | | | | | | 8 | R Reserved. |
| | | | | | | | | 9 | R Reserved. |
| | | | | | | | I/O | 10 | SEC_PIO0_11 Secure GPIO pin. |
| PIO0_12/ ADC0_10 | C2 | 5 | E2 | 12 | [2] | PU | I/O; AI | 0 | PIO0_12/ADC0_10 General-purpose digital input/output pin. ADC single ended input channel 2B - CH2B. Can optionally be paired with CH2A as the negative differential input on ADC1 channel 2. |
| | | | | | | | I/O | 1 | FC3_TXD_SCL_MISO_WS Flexcomm 3: USART transmitter, I2C clock, SPI master-in/slave-out data I/O, I2S word-select/frame. |
| | | | | | | | O | 2 | SD1_BACKEND_PWR SD/MMC 1 back-end power supply for embedded device. |
| | | | | | | | I | 3 | FREQME_GPIO_CLK_B Frequency Measure pin clock input B. |
| | | | | | | | I | 4 | SCT0_GPI7 Pin input 7 to SCTimer/PWM. |
| | | | | | | | O | 5 | SD0_POW_EN SD/MMC 0 card power enable. |
| | | | | | | | I/O | 6 | SWDIO Serial Wire Debug I/O. This is the default function after booting. |
| | | | | | | | I/O | 7 | FC6_TXD_SCL_MISO_WS Flexcomm 6: USART transmitter, I2C clock, SPI master-in/slave-out data I/O, I2S word-select/frame. |
| | | | | | | | | 8 | R Reserved. |
| | | | | | | | | 9 | R Reserved. |
| PIO0_13 | D9 | 46 | C12 | 71 | [5] | Z | I/O | 0 | PIO0_13 General-purpose digital input/output pin. Remark: In ISP mode, this pin is set to the Flexcomm 1 I2C SDA function. |
| | | | | | | | I/O | 1 | FC1_CTS_SDA_SSEL0 |

Table 3. Pin description...continued

| Symbol | 59 pin VFBGA | 64 pin HTQFP | 98 pin VFBGA | 100 pin HLQFP | | Reset state [1] | Type | Function # | Description |
|---------|--------------|--------------|--------------|---------------|-----|-----------------|------|------------|--|
| | | | | | | | | | Flexcomm 1: USART clear-to-send, I2C data I/O, SPI Slave Select 0. |
| | | | | | | | I | 2 | UTICK_CAP0 Micro-tick timer capture input 0. |
| | | | | | | | I | 3 | CTIMER_INP0 Capture input to CTIMER input multiplexers. |
| | | | | | | | I | 4 | SCT0_GPI0 Pin input 0 to SCTimer/PWM. |
| | | | | | | | I/O | 5 | FC1_RXD_SDA_MOSI_DATA Flexcomm 1: USART receiver, I2C data I/O, SPI master-out/slave-in data, I2S data I/O. |
| | | | | | | | | 6 | R Reserved. |
| | | | | | | | | 7 | R Reserved. |
| | | | | | | | | 8 | R Reserved. |
| | | | | | | | I | 9 | PLU_INPUT0 PLU input 0. |
| | | | | | | | I/O | 10 | SEC_PIO0_13 Secure GPIO pin. |
| PIO0_14 | D8 | 47 | C13 | 72 | [5] | Z | I/O | 0 | PIO0_14 General-purpose digital input/output pin. Remark: In ISP mode, this pin is set to the Flexcomm 1 I2C SCL function. |
| | | | | | | | I/O | 1 | FC1_RTS_SCL_SSEL1 Flexcomm 1: USART request-to-send, I2C clock, SPI slave select 1. |
| | | | | | | | I | 2 | UTICK_CAP1 Micro-tick timer capture input 1. |
| | | | | | | | I | 3 | CTIMER_INP1 Capture input to CTIMER input multiplexers. |
| | | | | | | | I | 4 | SCT0_GPI1 Pin input 1 to SCTimer/PWM. |
| | | | | | | | | 5 | R Reserved. |
| | | | | | | | I/O | 6 | FC1_TXD_SCL_MISO_WS Flexcomm 1: USART transmitter, I2C clock, SPI master-in/slave-out data I/O, I2S word-select/frame. |

Table 3. Pin description...continued

| Symbol | 59 pin VFBGA | 64 pin HTQFP | 98 pin VFBGA | 100 pin HLQFP | | Reset state [1] | Type | Function # | Description | |
|--------------------|--------------|--------------|--------------|---------------|-----|-----------------|------------|------------|---|--|
| | | | | | | | | 7 | R Reserved. | |
| | | | | | | | | 8 | R Reserved. | |
| | | | | | | | I | 9 | PLU_INPUT1 PLU input 1. | |
| | | | | | | | I/O | 10 | SEC_PIO0_14 Secure GPIO pin. | |
| PIO0_15/ ADC0_2 | F2 | 14 | L2 | 22 | [2] | Z | I/O; AI | 0 | PIO0_15/ADC0_2 General-purpose digital input/output pin. ADC single ended input channel 2A - CH2A. Can optionally be paired with CH2B as the positive differential input on ADC1 channel 2. | |
| | | | | | | | | I/O | 1 | FC6_CTS_SDA_SSEL0 Flexcomm 6: USART clear-to-send, I2C data I/O, SPI Slave Select 0. |
| | | | | | | | | I | 2 | UTICK_CAP2 Micro-tick timer capture input 2. |
| | | | | | | | | I | 3 | CTIMER_INP16 Capture input to CTIMER input multiplexers. |
| | | | | | | | | O | 4 | SCT0_OUT2 SCTimer/PWM output 2. |
| | | | | | | | | I | 5 | SD0_WR_PRT SD/MMC 0 write protect. |
| | | | | | | | | | 6 | R Reserved. |
| | | | | | | | | | 7 | R Reserved. |
| | | | | | | | | | 8 | R Reserved. |
| | | | | | | | | | 9 | R Reserved. |
| | | | | | | | I/O | 10 | SEC_PIO0_15 Secure GPIO pin. | |
| PIO0_16/ ADC0_8 | D1 | 7 | J2 | 14 | [2] | Z | I/O; AI | 0 | PIO0_16/ADC0_8 General-purpose digital input/output pin. ADC single ended input channel 0B - CH0B. Can optionally be paired with CH0A as the negative differential input on ADC1 channel 0. | |

Table 3. Pin description...continued

| Symbol | 59 pin VFBGA | 64 pin HTQFP | 98 pin VFBGA | 100 pin HLQFP | | Reset state [1] | Type | Function # | Description |
|---------|--------------|--------------|---|---------------|-----|-----------------|------|------------|--|
| | | | | | | | I/O | 1 | FC4_TXD_SCL_MISO_WS Flexcomm 4: USART transmitter, I2C clock, SPI master-in/slave-out data I/O, I2S word-select/frame. |
| | | | | | | | O | 2 | CLKOUT Output of the CLKOUT function. |
| | | | | | | | I | 3 | CTIMER_INP4 Capture input to CTIMER input multiplexers. |
| | | | | | | | | 4 | R Reserved. |
| | | | | | | | | 5 | R Reserved. |
| | | | | | | | | 6 | R Reserved. |
| | | | | | | | | 7 | R Reserved. |
| | | | | | | | | 8 | R Reserved. |
| | | | | | | | | 9 | R Reserved. |
| | | | | | | | | I/O | 10 |
| PIO0_17 | B1 | 3 | G3 | 8 | [3] | Z | I/O | 0 | PIO0_17 General-purpose digital input/output pin. |
| | | | | | | | I/O | 1 | FC4_SSEL2 Flexcomm 4: SPI slave select 2. |
| | | | | | | | I | 2 | SD0_CARD_DET_N SD/MMC 0 card detect (active low). |
| | | | | | | | I | 3 | SCT0_GPI7 Pin input 7 to SCTimer/PWM. |
| | | | | | | | O | 4 | SCT0_OUT0 SCTimer/PWM output 0. |
| | | | | | | | | 5 | R Reserved. |
| | | | | | | | | 6 | R Reserved. |
| | | | | | | | | 7 | R Reserved. |
| | I | 8 | SD0_CARD_INT_N SD/MMC 0 card interrupt. | | | | | | |

Table 3. Pin description...continued

| Symbol | 59 pin VFBGA | 64 pin HTQFP | 98 pin VFBGA | 100 pin HLQFP | | Reset state [1] | Type | Function # | Description |
|---------------------|--------------|---|--------------|---------------|-----|-----------------|---------|------------|---|
| | | | | | | | I | 9 | PLU_INPUT2 PLU input 2. |
| | | | | | | | I/O | 10 | SEC_PIO0_17 Secure GPIO pin. |
| PIO0_18/ ACMP0_C | H9 | 38 | H9 | 56 | [2] | Z | I/O; AI | 0 | PIO0_18/ACMP0_C General-purpose digital input/output pin. Comparator 0, input C if the DIGIMODE bit is set to 0 and ANAMODE is set to 1 in the IOCON register for this pin. |
| | | | | | | | I/O | 1 | FC4_CTS_SDA_SSEL0 Flexcomm 4: USART clear-to-send, I2C data I/O, SPI Slave Select 0. |
| | | | | | | | I | 2 | SD0_WR_PRT SD/MMC 0 write protect. |
| | | | | | | | O | 3 | CTIMER1_MAT0 32-bit CTimer1 match output 0. |
| | | | | | | | O | 4 | SCT0_OUT1 SCTimer/PWM output 1. |
| | | | | | | | | 5 | R Reserved. |
| | | | | | | | | 6 | R Reserved. |
| | | | | | | | | 7 | R Reserved. |
| | | | | | | | | 8 | R Reserved. |
| | | | | | | | I | 9 | PLU_INPUT3 PLU input 3. |
| | | | | | | | I/O | 10 | SEC_PIO0_18 Secure GPIO pin. |
| | | | | | | | PIO0_19 | C4 | 58 |
| I/O | 1 | FC4_RTS_SCL_SSEL1 Flexcomm 4: USART request-to-send, I2C clock, SPI slave select 1. | | | | | | | |
| I | 2 | UTICK_CAP0 Micro-tick timer capture input 0. | | | | | | | |
| O | 3 | CTIMER0_MAT2 32-bit CTimer0 match output 2. | | | | | | | |
| O | 4 | SCT0_OUT2 SCTimer/PWM output 2. | | | | | | | |

Table 3. Pin description...continued

| Symbol | 59 pin VFBGA | 64 pin HTQFP | 98 pin VFBGA | 100 pin HLQFP | | Reset state ^[1] | Type | Function # | Description |
|---------|--------------|--------------|--------------|---------------|----------------|----------------------------|------|------------|--|
| | | | | | | | | 5 | R Reserved. |
| | | | | | | | | 6 | R Reserved. |
| | | | | | | | I/O | 7 | FC7_TXD_SCL_MISO_WS Flexcomm 7: USART transmitter, I2C clock, SPI master-in/slave-out data I/O, I2S word-select/frame. |
| | | | | | | | | 8 | R Reserved. |
| | | | | | | | I | 9 | PLU_INPUT4 PLU input 4. |
| | | | | | | | I/O | 10 | SEC_PIO0_19 Secure GPIO pin. |
| PIO0_20 | C8 | 48 | B12 | 74 | ^[3] | Z | I/O | 0 | PIO0_20 General-purpose digital input/output pin. |
| | | | | | | | I/O | 1 | FC3_CTS_SDA_SSEL0 Flexcomm 3: USART clear-to-send, I2C data I/O, SPI Slave Select 0. |
| | | | | | | | O | 2 | CTIMER1_MAT1 32-bit CTimer1 match output 1. |
| | | | | | | | I | 3 | CTIMER_INP15 Capture input to CTIMER input multiplexers. |
| | | | | | | | I | 4 | SCT0_GPI2 Pin input 2 to SCTimer/PWM. |
| | | | | | | | | 5 | R Reserved. |
| | | | | | | | | 6 | R Reserved. |
| | | | | | | | I/O | 7 | FC7_RXD_SDA_MOSI_DATA Flexcomm 7: USART receiver, I2C data I/O, SPI master-out/slave-in data, I2S data I/O. |
| | | | | | | | I/O | 8 | HS_SPI_SSEL0 Slave Select 0 for high speed SPI. |
| | | | | | | | I | 9 | PLU_INPUT5 PLU input 5. |
| | | | | | | | I/O | 10 | SEC_PIO0_20 Secure GPIO pin. |
| | | | | | | | I/O | 11 | FC4_TXD_SCL_MISO_WS |

Table 3. Pin description...continued

| Symbol | 59 pin VFBGA | 64 pin HTQFP | 98 pin VFBGA | 100 pin HLQFP | | Reset state [1] | Type | Function # | Description |
|---------|--------------|--|--------------|---------------|--------|-----------------|------|------------|--|
| | | | | | | | | | Flexcomm 4: USART transmitter, I2C clock, SPI master-in/slave-out data I/O, I2S word-select/frame. |
| PIO0_21 | B8 | 49 | A12 | 76 | [3] | Z | I/O | 0 | PIO0_21 General-purpose digital input/output pin. |
| | | | | | | | I/O | 1 | FC3_RTS_SCL_SSEL1 Flexcomm 3: USART request-to-send, I2C clock, SPI slave select 1. |
| | | | | | | | I | 2 | UTICK_CAP3 Micro-tick timer capture input 3. |
| | | | | | | | O | 3 | CTIMER3_MAT3 32-bit CTimer3 match output 3. |
| | | | | | | | I | 4 | SCT0_GPI3 Pin input 3 to SCTimer/PWM. |
| | | | | | | | | 5 | R Reserved. |
| | | | | | | | | 6 | R Reserved. |
| | | | | | | | I/O | 7 | FC7_SCK Flexcomm 7: USART, SPI, or I2S clock. |
| | | | | | | | | 8 | R Reserved. |
| | | | | | | | I | 9 | PLU_CLKIN PLU clock input. Maximum frequency on PLU clock input is 25 MHz. |
| I/O | 10 | SEC_PIO0_21 Secure GPIO pin. | | | | | | | |
| PIO0_22 | B9 | 50 | E9 | 78 | [3][6] | Z | I/O | 0 | PIO0_22 General-purpose digital input/output pin. |
| | | | | | | | I/O | 1 | FC6_TXD_SCL_MISO_WS Flexcomm 6: USART transmitter, I2C clock, SPI master-in/slave-out data I/O, I2S word-select/frame. |
| | | | | | | | I | 2 | UTICK_CAP1 Micro-tick timer capture input 1. |
| | | | | | | | I | 3 | CTIMER_INP15 Capture input to CTIMER input multiplexers. |
| | | | | | | | O | 4 | SCT0_OUT3 SCTimer/PWM output 3. |
| | 5 | R Reserved. | | | | | | | |

Table 3. Pin description...continued

| Symbol | 59 pin VFBGA | 64 pin HTQFP | 98 pin VFBGA | 100 pin HLQFP | | Reset state [1] | Type | Function # | Description |
|--------------------|--------------|--------------|--------------|---------------|-----|-----------------|------------|------------|---|
| | | | | | | | | 6 | R Reserved. |
| | | | | | | | I | 7 | USB0_VBUS Monitors the presence of USB0 bus power. |
| | | | | | | | I/O | 8 | SD1_D[0] SD/MMC 1 data 0. |
| | | | | | | | O | 9 | PLU_OUT7 PLU output 7. |
| | | | | | | | I/O | 10 | SEC_PIO0_22 Secure GPIO pin. |
| PIO0_23/ ADC0_0 | F3 | 12 | J1 | 20 | [2] | Z | I/O; AI | 0 | PIO0_23/ADC0_0 General-purpose digital input/output pin. ADC single ended input channel 0A - CH0A. Can optionally be paired with CH0B as the positive differential input on ADC1 channel 0. |
| | | | | | | | I/O | 1 | MCLK MCLK input or output for I2S. |
| | | | | | | | O | 2 | CTIMER1_MAT2 32-bit CTimer1 match output 2. |
| | | | | | | | O | 3 | CTIMER3_MAT3 32-bit CTimer3 match output 3. |
| | | | | | | | O | 4 | SCT0_OUT4 SCTimer/PWM output 4. |
| | | | | | | | I/O | 5 | FC0_CTS_SDA_SSEL0 Flexcomm 0: USART clear-to-send, I2C data I/O, SPI Slave Select 0. |
| | | | | | | | | 6 | R Reserved. |
| | | | | | | | | 7 | R Reserved. |
| | | | | | | | I/O | 8 | SD1_D[1] SD/MMC 1 data 1. |
| | | | | | | | | 9 | R Reserved. |
| | | | | | | | I/O | 10 | SEC_PIO0_23 Secure GPIO pin. |
| PIO0_24 | - | 45 | E12 | 70 | [3] | Z | I/O | 0 | PIO0_24 General-purpose digital input/output pin. |
| | | | | | | | I/O | 1 | FC0_RXD_SDA_MOSI_DATA Flexcomm 0: USART receiver, I2C data I/O, SPI master-out/slave-in data, I2S data I/O. |

Table 3. Pin description...continued

| Symbol | 59 pin VFBGA | 64 pin HTQFP | 98 pin VFBGA | 100 pin HLQFP | | Reset state ^[1] | Type | Function # | Description |
|---------|--------------|--------------|--------------|---------------|--|----------------------------|------|------------|--|
| | | | | | | | I/O | 2 | SD0_D[0] SD/MMC 0 data 0. |
| | | | | | | | I | 3 | CTIMER_INP8 Capture input to CTIMER input multiplexers. |
| | | | | | | | I | 4 | SCT0_GPI0 Pin input 0 to SCTimer/PWM. |
| | | | | | | | | 5 | R Reserved. |
| | | | | | | | | 6 | R Reserved. |
| | | | | | | | | 7 | R Reserved. |
| | | | | | | | | 8 | R Reserved. |
| | | | | | | | | 9 | R Reserved. |
| | | | | | | | I/O | 10 | SEC_PIO0_24 Secure GPIO pin. |
| PIO0_25 | A9 | 51 | A11 | 79 | | ^[3] Z | I/O | 0 | PIO0_25 General-purpose digital input/output pin. |
| | | | | | | | I/O | 1 | FC0_TXD_SCL_MISO_WS Flexcomm 0: USART transmitter, I2C clock, SPI master-in/slave-out data I/O, I2S word-select/frame. |
| | | | | | | | I/O | 2 | SD0_D[1] SD/MMC 0 data 1. |
| | | | | | | | I | 3 | CTIMER_INP9 Capture input to CTIMER input multiplexers. |
| | | | | | | | I | 4 | SCT0_GPI1 Pin input 1 to SCTimer/PWM. |
| | | | | | | | | 5 | R Reserved. |
| | | | | | | | | 6 | R Reserved. |
| | | | | | | | | 7 | R Reserved. |
| | | | | | | | | 8 | R Reserved. |
| | | | | | | | | 9 | R |

Table 3. Pin description...continued

| Symbol | 59 pin VFBGA | 64 pin HTQFP | 98 pin VFBGA | 100 pin HLQFP | | Reset state [1] | Type | Function # | Description |
|---------|--------------|--|--------------|---------------|--------|-----------------|------|------------|---|
| | | | | | | | | | Reserved. |
| | | | | | | | I/O | 10 | SEC_PIO0_25 Secure GPIO pin. |
| PIO0_26 | F8 | 40 | H12 | 60 | [3][6] | Z | I/O | 0 | PIO0_26 General-purpose digital input/output pin. Remark: In ISP mode, this pin is set to the HS SPI MOSI function (Flexcomm 8) |
| | | | | | | | I/O | 1 | FC2_RXD_SDA_MOSI_DATA Flexcomm 2: USART receiver, I2C data I/O, SPI master-out/slave-in data, I2S data I/O. |
| | | | | | | | O | 2 | CLKOUT Output of the CLKOUT function. |
| | | | | | | | I | 3 | CTIMER_INP14 Capture input to CTIMER input multiplexers. |
| | | | | | | | O | 4 | SCT0_OUT5 SCTimer/PWM output 5. |
| | | | | | | | | 5 | R Reserved. |
| | | | | | | | | 6 | R Reserved. |
| | | | | | | | I | 7 | USB0_IDVALUE Indicates to the transceiver whether connected as an A-device (USB0_ID LOW) or B-device (USB0_ID HIGH). |
| | | | | | | | I/O | 8 | FC0_SCK Flexcomm 0: USART, SPI, or I2S clock. |
| | | | | | | | I/O | 9 | HS_SPI_MOSI Master-out/slave-in data for high speed SPI. |
| I/O | 10 | SEC_PIO0_26 Secure GPIO pin. | | | | | | | |
| PIO0_27 | G2 | 18 | N2 | 27 | [3] | Z | I/O | 0 | PIO0_27 General-purpose digital input/output pin. |
| | | | | | | | I/O | 1 | FC2_TXD_SCL_MISO_WS Flexcomm 2: USART transmitter, I2C clock, SPI master-in/slave-out data I/O, I2S word-select/frame. |
| | | | | | | | | 2 | R Reserved. |
| | | | | | | | O | 3 | CTIMER3_MAT2 32-bit CTimer3 match output 2. |

Table 3. Pin description...continued

| Symbol | 59 pin VFBGA | 64 pin HTQFP | 98 pin VFBGA | 100 pin HLQFP | | Reset state [1] | Type | Function # | Description |
|--------------------|--------------|--------------|--------------|---------------|--------|-----------------|------|------------|--|
| | | | | | | | O | 4 | SCT0_OUT6 SCTimer/PWM output 6. |
| | | | | | | | | 5 | R Reserved. |
| | | | | | | | | 6 | R Reserved. |
| | | | | | | | I/O | 7 | FC7_RXD_SDA_MOSI_DATA Flexcomm 7: USART receiver, I2C data I/O, SPI master-out/slave-in data, I2S data I/O. |
| | | | | | | | | 8 | R Reserved. |
| | | | | | | | O | 9 | PLU_OUT0 PLU output 0. |
| | | | | | | | I/O | 10 | SEC_PIO0_27 Secure GPIO pin. |
| PIO0_28/ WAKEUP | D7 | 44 | F13 | 66 | [3][6] | Z | I/O | 0 | PIO0_28 General-purpose digital input/output pin. This pin can trigger a wake-up from deep power-down mode. WAKEUP pin can be configured as rising or falling edge |
| | | | | | | | I/O | 1 | FC0_SCK Flexcomm 0: USART, SPI, or I2S clock. |
| | | | | | | | I/O | 2 | SD1_CMD SD/MMC 1 card command I/O. |
| | | | | | | | I | 3 | CTIMER_INP11 Capture input to CTIMER input multiplexers. |
| | | | | | | | O | 4 | SCT0_OUT7 SCTimer/PWM output 7. |
| | | | | | | | | 5 | R Reserved. |
| | | | | | | | | 6 | R Reserved. |
| | | | | | | | I | 7 | USB0_OVERCURRENTN USB0 bus overcurrent indicator (active low). |
| | | | | | | | | 8 | R Reserved. |
| | | | | | | | O | 9 | PLU_OUT1 PLU output 1. |

Table 3. Pin description...continued

| Symbol | 59 pin VFBGA | 64 pin HTQFP | 98 pin VFBGA | 100 pin HLQFP | | Reset state [1] | Type | Function # | Description |
|---------|--------------|--------------|--------------|---------------|-----|-----------------|------|------------|--|
| | | | | | | | I/O | 10 | SEC_PIO0_28 Secure GPIO pin. |
| PIO0_29 | A4 | 59 | H8 | 92 | [3] | Z | I/O | 0 | PIO0_29 General-purpose digital input/output pin. Remark: In ISP mode, this pin is set to the Flexcomm 0 USART RXD function. |
| | | | | | | | I/O | 1 | FC0_RXD_SDA_MOSI_DATA Flexcomm 0: USART receiver, I2C data I/O, SPI master-out/slave-in data, I2S data I/O. |
| | | | | | | | I/O | 2 | SD1_D[2] SD/MMC 1 data 2. |
| | | | | | | | O | 3 | CTIMER2_MAT3 32-bit CTimer2 match output 3. |
| | | | | | | | O | 4 | SCT0_OUT8 SCTimer/PWM output 8. |
| | | | | | | | | 5 | R Reserved. |
| | | | | | | | | 6 | R Reserved. |
| | | | | | | | O | 7 | CMP0_OUT Analog comparator 0 output. |
| | | | | | | | | 8 | R Reserved. |
| | | | | | | | O | 9 | PLU_OUT2 PLU output 2. |
| | | | | | | | I/O | 10 | SEC_PIO0_29 Secure GPIO pin. |
| PIO0_30 | B4 | 60 | E5 | 94 | [3] | Z | I/O | 0 | PIO0_30 General-purpose digital input/output pin. Remark: In ISP mode, this pin is set to the Flexcomm 0 USART TXD function. |
| | | | | | | | I/O | 1 | FC0_TXD_SCL_MISO_WS Flexcomm 0: USART transmitter, I2C clock, SPI master-in/slave-out data I/O, I2S word-select/frame. |
| | | | | | | | I/O | 2 | SD1_D[3] SD/MMC 1 data 3. |
| | | | | | | | O | 3 | CTIMER0_MAT0 32-bit CTimer0 match output 0. |
| | | | | | | | O | 4 | SCT0_OUT9 SCTimer/PWM output 9. |

Table 3. Pin description...continued

| Symbol | 59 pin VFBGA | 64 pin HTQFP | 98 pin VFBGA | 100 pin HLQFP | | Reset state [1] | Type | Function # | Description | |
|--------------------|--------------|--------------|--------------|---------------|-----|-----------------|------------|------------|---|--|
| | | | | | | | | 5 | R Reserved. | |
| | | | | | | | | 6 | R Reserved. | |
| | | | | | | | | 7 | R Reserved. | |
| | | | | | | | | 8 | R Reserved. | |
| | | | | | | | | 9 | R Reserved. | |
| | | | | | | | I/O | 10 | SEC_PIO0_30 Secure GPIO pin. | |
| PIO0_31/ ADC0_3 | - | 15 | L1 | 23 | [2] | Z | I/O; AI | 0 | PIO0_31/ADC0_3 General-purpose digital input/output pin. ADC single ended input channel 3A - CH3A. Can optionally be paired with CH3B as the positive differential input on ADC1 channel 3. | |
| | | | | | | | | I/O | 1 | FC0_CTS_SDA_SSEL0 Flexcomm 0: USART clear-to-send, I2C data I/O, SPI Slave Select 0. |
| | | | | | | | | I/O | 2 | SD0_D[2] SD/MMC 0 data 2. |
| | | | | | | | | O | 3 | CTIMER0_MAT1 32-bit CTimer0 match output 1. |
| | | | | | | | | O | 4 | SCT0_OUT3 SCTimer/PWM output 3. |
| | | | | | | | | | 5 | R Reserved. |
| | | | | | | | | | 6 | R Reserved. |
| | | | | | | | | | 7 | R Reserved. |
| | | | | | | | | | 8 | R Reserved. |
| | | | | | | | | | 9 | R Reserved. |
| | | | | | | | I/O | 10 | SEC_PIO0_31 Secure GPIO pin. | |
| PIO1_0/ ADC0_11 | B2 | 4 | E1 | 11 | [2] | Z | I/O; AI | 0 | PIO1_0/ADC0_11 General-purpose digital input/output pin. ADC single ended input channel 3B - | |

Table 3. Pin description...continued

| Symbol | 59 pin VFBGA | 64 pin HTQFP | 98 pin VFBGA | 100 pin HLQFP | Reset state [1] | Type | Function # | Description |
|-------------------|--------------|--------------|--------------|---------------|-----------------|------|------------|--|
| | | | | | | | | CH3B. Can optionally be paired with CH3A as the negative differential input on ADC1 channel 3. |
| | | | | | | I/O | 1 | FC0_RTS_SCL_SSEL1 Flexcomm 0: USART request-to-send, I2C clock, SPI slave select 1. |
| | | | | | | I/O | 2 | SD0_D[3] SD/MMC 0 data 3. |
| | | | | | | I | 3 | CTIMER_INP2 Capture input to CTIMER input multiplexers. |
| | | | | | | I | 4 | SCT0_GPI4 Pin input 4 to SCTimer/PWM. |
| | | | | | | | 5 | R Reserved. |
| | | | | | | | 6 | R Reserved. |
| | | | | | | | 7 | R Reserved. |
| | | | | | | | 8 | R Reserved. |
| | | | | | | O | 9 | PLU_OUT3 PLU output 3. |
| PIO1_1/ WAKEUP | G8 | 39 | G11 | 59 | [3][6] | Z | 0 | PIO1_1 General-purpose digital input/output pin. This pin can trigger a wake-up from deep power-down mode. WAKEUP pin can be configured as rising or falling edge Remark: In ISP mode, this pin is set to the High Speed SPI SSEL1 function (Flexcomm 8) |
| | | | | | | I/O | 1 | FC3_RXD_SDA_MOSI_DATA Flexcomm 3: USART receiver, I2C data I/O, SPI master-out/slave-in data, I2S data I/O. |
| | | | | | | | 2 | R Reserved. |
| | | | | | | I | 3 | CTIMER_INP3 Capture input to CTIMER input multiplexers. |
| | | | | | | I | 4 | SCT0_GPI5 Pin input 5 to SCTimer/PWM. |
| | | | | | | I/O | 5 | HS_SPI_SSEL1 |

Table 3. Pin description...continued

| Symbol | 59 pin VFBGA | 64 pin HTQFP | 98 pin VFBGA | 100 pin HLQFP | | Reset state [1] | Type | Function # | Description |
|--------|----------------------------------|--------------|--------------|---------------|--------|-----------------|------|------------|---|
| | | | | | | | | | Slave Select 1 for high speed SPI. |
| | | | | | | | | 6 | R Reserved. |
| | | | | | | | I | 7 | USB1_OVERCURRENTN USB1 bus overcurrent indicator (active low). |
| | | | | | | | | 8 | R Reserved. |
| | | | | | | | O | 9 | PLU_OUT4 PLU output 4. |
| PIO1_2 | F9 | 41 | G12 | 61 | [3][6] | Z | I/O | 0 | PIO1_2 General-purpose digital input/output pin. Remark: In ISP mode, this pin is set to the High Speed SPI SCK function (Flexcomm 8). |
| | | | | | | | | 1 | R Reserved. |
| | | | | | | | | 2 | R Reserved. |
| | | | | | | | | O 3 | CTIMER0_MAT3 32-bit CTimer0 match output 3. |
| | | | | | | | | I 4 | SCT0_GPI6 Pin input 6 to SCTimer/PWM. |
| | | | | | | | | 5 | R Reserved. |
| | | | | | | | | I/O 6 | HS_SPI_SCK Clock for high speed SPI. |
| | | | | | | | | O 7 | USB1_PORTPWRN USB1 VBUS drive indicator (Indicates VBUS must be driven). |
| | | | | | | | | 8 | R Reserved. |
| O 9 | PLU_OUT5 PLU output 5. | | | | | | | | |
| PIO1_3 | F7 | 42 | G13 | 62 | [3][6] | Z | I/O | 0 | PIO1_3 General-purpose digital input/output pin. Remark: In ISP mode, this pin is set to the High Speed SPI MISO function (Flexcomm 8). |
| | | | | | | | | 1 | R Reserved. |
| | | | | | | | | 2 | R |

Table 3. Pin description...continued

| Symbol | 59 pin VFBGA | 64 pin HTQFP | 98 pin VFBGA | 100 pin HLQFP | | Reset state [1] | Type | Function # | Description |
|--------|--------------|--------------|--------------|---------------|-----|-----------------|------|------------|---|
| | | | | | | | | | Reserved. |
| | | | | | | | | 3 | R Reserved. |
| | | | | | | | O | 4 | SCT0_OUT4 SCTimer/PWM output 4. |
| | | | | | | | | 5 | R Reserved. |
| | | | | | | | I/O | 6 | HS_SPI_MISO Master-in/slave-out data for high speed SPI. |
| | | | | | | | O | 7 | USB0_PORTPWRN USB0 VBUS drive indicator (Indicates VBUS must be driven). |
| | | | | | | | | 8 | R Reserved. |
| | | | | | | | O | 9 | PLU_OUT6 PLU output 6. |
| PIO1_4 | B3 | - | B2 | 1 | [3] | Z | I/O | 0 | PIO1_4 General-purpose digital input/output pin. |
| | | | | | | | I/O | 1 | FC0_SCK Flexcomm 0: USART, SPI, or I2S clock. |
| | | | | | | | I/O | 2 | SD0_D[0] SD/MMC 0 data 0. |
| | | | | | | | O | 3 | CTIMER2_MAT1 32-bit CTimer2 match output 1. |
| | | | | | | | O | 4 | SCT0_OUT0 SCTimer/PWM output 0. |
| | | | | | | | I | 5 | FREQME_GPIO_CLK_A Frequency Measure pin clock input A. |
| PIO1_5 | - | - | M5 | 31 | [3] | Z | I/O | 0 | PIO1_5 General-purpose digital input/output pin. |
| | | | | | | | I/O | 1 | FC0_RXD_SDA_MOSI_DATA Flexcomm 0: USART receiver, I2C data I/O, SPI master-out/slave-in data, I2S data I/O. |
| | | | | | | | I/O | 2 | SD0_D[2] SD/MMC 0 data 2. |
| | | | | | | | O | 3 | CTIMER2_MAT0 32-bit CTimer2 match output 0. |
| | | | | | | | I | 4 | SCT0_GPIO Pin input 0 to SCTimer/PWM. |
| PIO1_6 | - | - | H5 | 5 | [3] | Z | I/O | 0 | PIO1_6 |

Table 3. Pin description...continued

| Symbol | 59 pin VFBGA | 64 pin HTQFP | 98 pin VFBGA | 100 pin HLQFP | | Reset state [1] | Type | Function # | Description |
|--------------------|--------------|--------------|--------------|---------------|-----|-----------------|------------|------------|--|
| | | | | | | | | | General-purpose digital input/output pin. |
| | | | | | | | I/O | 1 | FC0_TXD_SCL_MISO_WS Flexcomm 0: USART transmitter, I2C clock, SPI master-in/slave-out data I/O, I2S word-select/frame. |
| | | | | | | | I/O | 2 | SD0_D[3] SD/MMC 0 data 3. |
| | | | | | | | O | 3 | CTIMER2_MAT1 32-bit CTimer2 match output 1. |
| | | | | | | | I | 4 | SCT0_GPI3 Pin input 3 to SCTimer/PWM. |
| PIO1_7 | - | - | J5 | 9 | [3] | Z | I/O | 0 | PIO1_7 General-purpose digital input/output pin. |
| | | | | | | | I/O | 1 | FC0_RTS_SCL_SSEL1 Flexcomm 0: USART request-to-send, I2C clock, SPI slave select 1. |
| | | | | | | | I/O | 2 | SD0_D[1] SD/MMC 0 data 1. |
| | | | | | | | O | 3 | CTIMER2_MAT2 32-bit CTimer2 match output 2. |
| | | | | | | | I | 4 | SCT0_GPI4 Pin input 4 to SCTimer/PWM. |
| PIO1_8/ ADC0_4 | - | - | A6 | 24 | [2] | Z | I/O; AI | 0 | PIO1_8/ADC0_4 General-purpose digital input/output pin. ADC single ended input channel 4A - CH4A. Can optionally be paired with CH4B as the positive differential input on ADC1 channel 4. |
| | | | | | | | I/O | 1 | FC0_CTS_SDA_SSEL0 Flexcomm 0: USART clear-to-send, I2C data I/O, SPI Slave Select 0. |
| | | | | | | | O | 2 | SD0_CLK SD/MMC 0 card clock. |
| | | | | | | | | 3 | R Reserved. |
| | | | | | | | O | 4 | SCT0_OUT1 SCTimer/PWM output 1. |
| | | | | | | | I/O | 5 | FC4_SSEL2 Flexcomm 4: SPI slave select 2. |
| PIO1_9/ ADC0_12 | - | - | C1 | 10 | [2] | Z | I/O; AI | 0 | PIO1_9/ADC0_12 General-purpose digital input/output pin. ADC single ended input channel 4B - CH4B. Can optionally be paired with CH4A |

Table 3. Pin description...continued

| Symbol | 59 pin VFBGA | 64 pin HTQFP | 98 pin VFBGA | 100 pin HLQFP | | Reset state [1] | Type | Function # | Description |
|---------|--------------|--------------|--------------|---------------|--------|-----------------|------|------------|---|
| | | | | | | | | | as the negative differential input on ADC1 channel 4. |
| | | | | | | | | 1 | R Reserved. |
| | | | | | | | I/O | 2 | FC1_SCK Flexcomm 1: USART, SPI, or I2S clock. |
| | | | | | | | I | 3 | CTIMER_INP4 Capture input to CTIMER input multiplexers. |
| | | | | | | | O | 4 | SCT0_OUT2 SCTimer/PWM output 2. |
| | | | | | | | I/O | 5 | FC4_CTS_SDA_SSEL0 Flexcomm 4: USART clear-to-send, I2C data I/O, SPI Slave Select 0. |
| | | | | | | | | 6 | R Reserved. |
| | | | | | | | | 7 | R Reserved. |
| | | | | | | | | 8 | R Reserved. |
| PIO1_10 | - | - | J7 | 40 | [3] | Z | I/O | 0 | PIO1_10 General-purpose digital input/output pin. |
| | | | | | | | | 1 | R Reserved. |
| | | | | | | | I/O | 2 | FC1_RXD_SDA_MOSI_DATA Flexcomm 1: USART receiver, I2C data I/O, SPI master-out/slave-in data, I2S data I/O. |
| | | | | | | | O | 3 | CTIMER1_MAT0 32-bit CTimer1 match output 0. |
| | | | | | | | O | 4 | SCT0_OUT3 SCTimer/PWM output 3. |
| | | | | | | | | 5 | R Reserved. |
| | | | | | | | | 6 | R Reserved. |
| | | | | | | | | 7 | R Reserved. |
| | | | | | | | | 8 | R Reserved. |
| PIO1_11 | - | - | G6 | 93 | [3][6] | Z | I/O | 0 | PIO1_11 General-purpose digital input/output pin. |

Table 3. Pin description...continued

| Symbol | 59 pin VFBGA | 64 pin HTQFP | 98 pin VFBGA | 100 pin HLQFP | | Reset state [1] | Type | Function # | Description |
|---------|--------------|--------------|--------------|---------------|--------|-----------------|------|------------|--|
| | | | | | | | | 1 | R Reserved. |
| | | | | | | | I/O | 2 | FC1_TXD_SCL_MISO_WS Flexcomm 1: USART transmitter, I2C clock, SPI master-in/slave-out data I/O, I2S word-select/frame. |
| | | | | | | | I | 3 | CTIMER_INP5 Capture input to CTIMER input multiplexers. |
| | | | | | | | I | 4 | USB0_VBUS Monitors the presence of USB0 bus power. |
| | | | | | | | | 5 | R Reserved. |
| | | | | | | | | 6 | R Reserved. |
| | | | | | | | | 7 | R Reserved. |
| | | | | | | | | 8 | R Reserved. |
| PIO1_12 | - | - | F12 | 67 | [3][6] | Z | I/O | 0 | PIO1_12 General-purpose digital input/output pin. |
| | | | | | | | | 1 | R Reserved. |
| | | | | | | | I/O | 2 | FC6_SCK Flexcomm 6: USART, SPI, or I2S clock. |
| | | | | | | | O | 3 | CTIMER1_MAT1 32-bit CTimer1 match output 1. |
| | | | | | | | O | 4 | USB0_PORTPWRN USB0 VBUS drive indicator (Indicates VBUS must be driven). |
| | | | | | | | I/O | 5 | HS_SPI_SSEL2 Slave Select 2 for high speed SPI. |
| PIO1_13 | - | - | B3 | 2 | [3][6] | Z | I/O | 0 | PIO1_13 General-purpose digital input/output pin. |
| | | | | | | | | 1 | R Reserved. |
| | | | | | | | I/O | 2 | FC6_RXD_SDA_MOSI_DATA Flexcomm 6: USART receiver, I2C data I/O, SPI master-out/slave-in data, I2S data I/O. |
| | | | | | | | I | 3 | CTIMER_INP6 Capture input to CTIMER input multiplexers. |

Table 3. Pin description...continued

| Symbol | 59 pin VFBGA | 64 pin HTQFP | 98 pin VFBGA | 100 pin HLQFP | | Reset state [1] | Type | Function # | Description |
|---------------------|--------------|--------------|--------------|---------------|--------|-----------------|------------|------------|---|
| | | | | | | | I | 4 | USB0_OVERCURRENTN USB0 bus overcurrent indicator (active low). |
| | | | | | | | O | 5 | USB0_FRAME USB0 frame toggle signal. |
| | | | | | | | | 6 | R Reserved. |
| | | | | | | | I | 7 | SD0_CARD_DET_N SD/MMC 0 card detect (active low). |
| PIO1_14/ ACMP0_D | - | - | L7 | 57 | [2][6] | Z | I/O; AI | 0 | PIO1_14/ACMP0_D General-purpose digital input/output pin. Comparator 0, input D if the DIGIMODE bit is set to 0 and ANAMODE is set to 1 in the IOCON register for this pin. |
| | | | | | | | | 1 | R Reserved. |
| | | | | | | | I | 2 | UTICK_CAP2 Micro-tick timer capture input 2. |
| | | | | | | | O | 3 | CTIMER1_MAT2 32-bit CTimer1 match output 2. |
| | | | | | | | I/O | 4 | FC5_CTS_SDA_SSEL0 Flexcomm 5: USART clear-to-send, I2C data I/O, SPI Slave Select 0. |
| | | | | | | | O | 5 | USB0_LEDN USB0-configured LED indicator (active low). |
| | | | | | | | | 6 | R Reserved. |
| | | | | | | | I/O | 7 | SD1_CMD SD/MMC 1 card command I/O. |
| PIO1_15 | - | - | B6 | 82 | [3] | Z | I/O | 0 | PIO1_15 General-purpose digital input/output pin. |
| | | | | | | | | 1 | R Reserved. |
| | | | | | | | I | 2 | UTICK_CAP3 Micro-tick timer capture input 3. |
| | | | | | | | I | 3 | CTIMER_INP7 Capture input to CTIMER input multiplexers. |
| | | | | | | | I/O | 4 | FC5_RTS_SCL_SSEL1 Flexcomm 5: USART request-to-send, I2C clock, SPI slave select 1. |

Table 3. Pin description...continued

| Symbol | 59 pin VFBGA | 64 pin HTQFP | 98 pin VFBGA | 100 pin HLQFP | | Reset state [1] | Type | Function # | Description |
|---------|--------------|--------------|--------------|---------------|-----|-----------------|------|------------|--|
| | | | | | | | I/O | 5 | FC4_RTS_SCL_SSEL1 Flexcomm 4: USART request-to-send, I2C clock, SPI slave select 1. |
| | | | | | | | | 6 | R Reserved. |
| | | | | | | | I/O | 7 | SD1_D[2] SD/MMC 1 data 2. |
| | | | | | | | | 8 | R Reserved. |
| PIO1_16 | - | - | C7 | 87 | [3] | Z | I/O | 0 | PIO1_16 General-purpose digital input/output pin. |
| | | | | | | | | 1 | R Reserved. |
| | | | | | | | I/O | 2 | FC6_TXD_SCL_MISO_WS Flexcomm 6: USART transmitter, I2C clock, SPI master-in/slave-out data I/O, I2S word-select/frame. |
| | | | | | | | O | 3 | CTIMER1_MAT3 32-bit CTimer1 match output 3. |
| | | | | | | | I/O | 4 | SD0_CMD SD/MMC 0 card command I/O. |
| | | | | | | | | 5 | R Reserved. |
| | | | | | | | | 6 | R Reserved. |
| | | | | | | | | 7 | R Reserved. |
| PIO1_17 | - | - | J9 | 43 | [3] | Z | I/O | 0 | PIO1_17 General-purpose digital input/output pin. |
| | | | | | | | | 1 | R Reserved. |
| | | | | | | | | 2 | R Reserved. |
| | | | | | | | I/O | 3 | FC6_RTS_SCL_SSEL1 Flexcomm 6: USART request-to-send, I2C clock, SPI slave select 1. |
| | | | | | | | O | 4 | SCT0_OUT4 SCTimer/PWM output 4. |
| | 5 | R | | | | | | | |

Table 3. Pin description...continued

| Symbol | 59 pin VFBGA | 64 pin HTQFP | 98 pin VFBGA | 100 pin HLQFP | | Reset state [1] | Type | Function # | Description | |
|----------------------------------|--------------|--------------|--------------|---------------|-----|-----------------|------------|------------|--|---|
| | | | | | | | | | Reserved. | |
| | | | | | | | | 6 | R Reserved. | |
| | | | | | | | I | 7 | SD1_CARD_INT_N SD/MMC 1 card interrupt. | |
| | | | | | | | | 8 | R Reserved. | |
| | | | | | | | I | 9 | SD1_CARD_DET_N SD/MMC 1 card detect (active low). | |
| PIO1_18/ WAKUP | - | - | G9 | 64 | [3] | Z | I/O | 0 | PIO1_18 General-purpose digital input/output pin. This pin can trigger a wake-up from deep power-down mode. | |
| | | | | | | | | O | 1 | SD1_POW_EN SD/MMC 1 card power enable. |
| | | | | | | | | | 2 | R Reserved. |
| | | | | | | | | | 3 | R Reserved. |
| | | | | | | | | O | 4 | SCT0_OUT5 SCTimer/PWM output 5. |
| | | | | | | | | | 5 | R Reserved. |
| | | | | | | | | | 6 | R Reserved. |
| | | | | | | | | O | 7 | PLU_OUT0 PLU output 0. |
| PIO1_19/ ACMPV _{REF} | - | - | H13 | 58 | [2] | Z | I/O; AI | 0 | PIO1_19/ACMPV_{REF} General-purpose digital input/output pin. Alternate reference voltage for the analog comparator if the DIGIMODE bit is set to 0 and ANAMODE is set to 1 in the IOCON register for this pin. | |
| | | | | | | | | | 1 | R Reserved. |
| | | | | | | | | O | 2 | SCT0_OUT7 SCTimer/PWM output 7. |
| | | | | | | | | O | 3 | CTIMER3_MAT1 32-bit CTimer3 match output 1. |

Table 3. Pin description...continued

| Symbol | 59 pin VFBGA | 64 pin HTQFP | 98 pin VFBGA | 100 pin HLQFP | | Reset state [1] | Type | Function # | Description |
|---------|--------------|--------------|--------------|---------------|-----|-----------------|------|------------|--|
| | | | | | | | I | 4 | SCT0_GPI7 Pin input 7 to SCTimer/PWM. |
| | | | | | | | I/O | 5 | FC4_SCK Flexcomm 4: USART, SPI, or I2S clock. |
| | | | | | | | | 6 | R Reserved. |
| | | | | | | | O | 7 | PLU_OUT1 PLU output 1. |
| | | | | | | | | 8 | R Reserved. |
| PIO1_20 | - | - | C2 | 4 | [3] | Z | I/O | 0 | PIO1_20 General-purpose digital input/output pin. |
| | | | | | | | I/O | 1 | FC7_RTS_SCL_SSEL1 Flexcomm 7: USART request-to-send, I2C clock, SPI slave select 1. |
| | | | | | | | | 2 | R Reserved. |
| | | | | | | | I | 3 | CTIMER_INP14 Capture input to CTIMER input multiplexers. |
| | | | | | | | | 4 | R Reserved. |
| | | | | | | | I/O | 5 | FC4_TXD_SCL_MISO_WS Flexcomm 4: USART transmitter, I2C clock, SPI master-in/slave-out data I/O, I2S word-select/frame. |
| | | | | | | | | 6 | R Reserved. |
| | | | | | | | O | 7 | PLU_OUT2 PLU output 2. |
| | | | | | | | | 8 | R Reserved. |
| PIO1_21 | - | - | M7 | 30 | [3] | Z | I/O | 0 | PIO1_21 General-purpose digital input/output pin. |
| | | | | | | | I/O | 1 | FC7_CTS_SDA_SSEL0 Flexcomm 7: USART clear-to-send, I2C data I/O, SPI Slave Select 0. |
| | | | | | | | | 2 | R Reserved. |
| | | | | | | | O | 3 | CTIMER3_MAT2 32-bit CTimer3 match output 2. |

Table 3. Pin description...continued

| Symbol | 59 pin VFBGA | 64 pin HTQFP | 98 pin VFBGA | 100 pin HLQFP | | Reset state [1] | Type | Function # | Description |
|---------|--------------|--------------|--------------|---------------|-----|-----------------|------|------------|---|
| | | | | | | | | 4 | R Reserved. |
| | | | | | | | I/O | 5 | FC4_RXD_SDA_MOSI_DATA Flexcomm 4: USART receiver, I2C data I/O, SPI master-out/slave-in data, I2S data I/O. |
| | | | | | | | | 6 | R Reserved. |
| | | | | | | | O | 7 | PLU_OUT3 PLU output 3. |
| | | | | | | | | 8 | R Reserved. |
| PIO1_22 | - | - | M8 | 41 | [3] | Z | I/O | 0 | PIO1_22 General-purpose digital input/output pin. |
| | | | | | | | | 1 | R Reserved. |
| | | | | | | | I/O | 2 | SD0_CMD SD/MMC 0 card command I/O. |
| | | | | | | | O | 3 | CTIMER2_MAT3 32-bit CTimer2 match output 3. |
| | | | | | | | I | 4 | SCT0_GPI5 Pin input 5 to SCTimer/PWM. |
| | | | | | | | I/O | 5 | FC4_SSEL3 Flexcomm 4: SPI slave select 3. |
| | | | | | | | | 6 | R Reserved. |
| | | | | | | | O | 7 | PLU_OUT4 PLU output 4. |
| PIO1_23 | - | - | J8 | 42 | [3] | Z | I/O | 0 | PIO1_23 General-purpose digital input/output pin. |
| | | | | | | | I/O | 1 | FC2_SCK Flexcomm 2: USART, SPI, or I2S clock. |
| | | | | | | | O | 2 | SCT0_OUT0 SCTimer/PWM output 0. |
| | | | | | | | I/O | 3 | SD1_D[3] SD/MMC 1 data 3. |
| | | | | | | | | 4 | R Reserved. |
| | | | | | | | I/O | 5 | FC3_SSEL2 Flexcomm 3: SPI slave select 2. |
| | | | | | | | | 6 | R |

Table 3. Pin description...continued

| Symbol | 59 pin VFBGA | 64 pin HTQFP | 98 pin VFBGA | 100 pin HLQFP | | Reset state ^[1] | Type | Function # | Description |
|---------|--------------|------------------|--------------|---------------|----------------|----------------------------|------|-----------------------|--|
| | | | | | | | | | Reserved. |
| | | | | | | | O | 7 | PLU_OUT5 PLU output 5. |
| | | | | | | | | 8 | R Reserved. |
| PIO1_24 | - | - | F6 | 3 | ^[3] | Z | I/O | 0 | PIO1_24 General-purpose digital input/output pin. |
| | | | | | | | I/O | 1 | FC2_RXD_SDA_MOSI_DATA Flexcomm 2: USART receiver, I2C data I/O, SPI master-out/slave-in data, I2S data I/O. |
| | | | | | | | O | 2 | SCT0_OUT1 SCTimer/PWM output 1. |
| | | | | | | | I/O | 3 | SD1_D[1] SD/MMC 1 data 1. |
| | | | | | | | | 4 | R Reserved. |
| | | | | | | | I/O | 5 | FC3_SSEL3 Flexcomm 3: SPI slave select 3. |
| | | | | | | | | 6 | R Reserved. |
| | | | | | | | O | 7 | PLU_OUT6 PLU output 6. |
| | | | | | | | 8 | R Reserved. | |
| PIO1_25 | - | - | B8 | 77 | ^[3] | Z | I/O | 0 | PIO1_25 General-purpose digital input/output pin. |
| | | | | | | | I/O | 1 | FC2_TXD_SCL_MISO_WS Flexcomm 2: USART transmitter, I2C clock, SPI master-in/slave-out data I/O, I2S word-select/frame. |
| | | | | | | | O | 2 | SCT0_OUT2 SCTimer/PWM output 2. |
| | | | | | | | I/O | 3 | SD1_D[0] SD/MMC 1 data 0. |
| | | | | | | | I | 4 | UTICK_CAP0 Micro-tick timer capture input 0. |
| | | | | | | | | 5 | R Reserved. |
| | | | | | | | | 6 | R Reserved. |
| I | 7 | PLU_CLKIN | | | | | | | |

Table 3. Pin description...continued

| Symbol | 59 pin VFBGA | 64 pin HTQFP | 98 pin VFBGA | 100 pin HLQFP | | Reset state ^[1] | Type | Function # | Description |
|---------|--------------|--------------|--------------|---------------|----------------|----------------------------|------|-----------------------|--|
| | | | | | | | | | PLU clock input. Maximum frequency on PLU clock input is 25 MHz. |
| | | | | | | | | 8 | R Reserved. |
| PIO1_26 | - | - | E13 | 68 | ^[3] | Z | I/O | 0 | PIO1_26 General-purpose digital input/output pin. |
| | | | | | | | I/O | 1 | FC2_CTS_SDA_SSEL0 Flexcomm 2: USART clear-to-send, I2C data I/O, SPI Slave Select 0. |
| | | | | | | | O | 2 | SCT0_OUT3 SCTimer/PWM output 3. |
| | | | | | | | I | 3 | CTIMER_INP3 Capture input to CTIMER input multiplexers. |
| | | | | | | | I | 4 | UTICK_CAP1 Micro-tick timer capture input 1. |
| | | | | | | | I/O | 5 | HS_SPI_SSEL3 Slave Select 3 for high speed SPI. |
| | | | | | | | | 6 | R Reserved. |
| | | | | | | | I | 7 | PLU_INPUT5 PLU input 5. |
| | | | | | | | 8 | R Reserved. | |
| PIO1_27 | - | - | E8 | 85 | ^[3] | Z | I/O | 0 | PIO1_27 General-purpose digital input/output pin. |
| | | | | | | | I/O | 1 | FC2_RTS_SCL_SSEL1 Flexcomm 2: USART request-to-send, I2C clock, SPI slave select 1. |
| | | | | | | | I/O | 2 | SD0_D[4] SD/MMC 0 data 4. |
| | | | | | | | O | 3 | CTIMER0_MAT3 32-bit CTimer0 match output 3. |
| | | | | | | | O | 4 | CLKOUT Output of the CLKOUT function. |
| | | | | | | | | 5 | R Reserved. |
| | | | | | | | | 6 | R Reserved. |
| | | | | | | | I | 7 | PLU_INPUT4 PLU input 4. |

Table 3. Pin description...continued

| Symbol | 59 pin VFBGA | 64 pin HTQFP | 98 pin VFBGA | 100 pin HLQFP | | Reset state [1] | Type | Function # | Description |
|--------------------|--------------|-----------------------------------|--------------|---------------|--------|-----------------|------|-----------------------|---|
| | | | | | | | | 8 | R Reserved. |
| PIO1_28 | - | - | A8 | 73 | [3] | Z | I/O | 0 | PIO1_28 General-purpose digital input/output pin. |
| | | | | | | | I/O | 1 | FC7_SCK Flexcomm 7: USART, SPI, or I2S clock. |
| | | | | | | | I/O | 2 | SD0_D[5] SD/MMC 0 data 5. |
| | | | | | | | I | 3 | CTIMER_INP2 Capture input to CTIMER input multiplexers. |
| | | | | | | | | 4 | R Reserved. |
| | | | | | | | | 5 | R Reserved. |
| | | | | | | | | 6 | R Reserved. |
| | | | | | | | I | 7 | PLU_INPUT3 PLU input 3. |
| | | | | | | | 8 | R Reserved. | |
| PIO1_29 | A8 | - | G8 | 80 | [3][6] | Z | I/O | 0 | PIO1_29 General-purpose digital input/output pin. |
| | | | | | | | I/O | 1 | FC7_RXD_SDA_MOSI_DATA Flexcomm 7: USART receiver, I2C data I/O, SPI master-out/slave-in data, I2S data I/O. |
| | | | | | | | I/O | 2 | SD0_D[6] SD/MMC 0 data 6. |
| | | | | | | | I | 3 | SCT0_GPI6 Pin input 6 to SCTimer/PWM. |
| | | | | | | | O | 4 | USB1_PORTPWRN USB1 VBUS drive indicator (Indicates VBUS must be driven). |
| | | | | | | | O | 5 | USB1_FRAME USB1 frame toggle signal. |
| | | | | | | | | 6 | R Reserved. |
| I | 7 | PLU_INPUT2 PLU input 2. | | | | | | | |
| PIO1_30/ WAKEUP | E7 | - | F9 | 65 | [3][6] | Z | I/O | 0 | PIO1_30 General-purpose digital input/output pin. |

Table 3. Pin description...continued

| Symbol | 59 pin VFBGA | 64 pin HTQFP | 98 pin VFBGA | 100 pin HLQFP | | Reset state [1] | Type | Function # | Description |
|---------|--------------|--------------|--------------|---------------|-----|-----------------|------|------------|--|
| | | | | | | | | | This pin can trigger a wake-up from deep power-down mode. WAKEUP pin can be configured as rising or falling edge. |
| | | | | | | | I/O | 1 | FC7_TXD_SCL_MISO_WS Flexcomm 7: USART transmitter, I2C clock, SPI master-in/slave-out data I/O, I2S word-select/frame. |
| | | | | | | | I/O | 2 | SD0_D[7] SD/MMC 0 data 7. |
| | | | | | | | I | 3 | SCT0_GPI7 Pin input 7 to SCTimer/PWM. |
| | | | | | | | I | 4 | USB1_OVERCURRENTN USB1 bus overcurrent indicator (active low). |
| | | | | | | | O | 5 | USB1_LEDN USB1-configured LED indicator (active low). |
| | | | | | | | | 6 | R Reserved. |
| | | | | | | | I | 7 | PLU_INPUT1 PLU input 1. |
| PIO1_31 | - | - | H6 | 91 | [3] | Z | I/O | 0 | PIO1_31 General-purpose digital input/output pin. |
| | | | | | | | I/O | 1 | MCLK MCLK input or output for I2S. |
| | | | | | | | O | 2 | SD1_CLK SD/MMC 1 card clock. |
| | | | | | | | O | 3 | CTIMER0_MAT2 32-bit CTimer0 match output 2. |
| | | | | | | | O | 4 | SCT0_OUT6 SCTimer/PWM output 6. |
| | | | | | | | | 5 | R Reserved. |
| | | | | | | | | 6 | R Reserved. |
| | | | | | | | I | 7 | PLU_INPUT0 PLU input 0. |
| | | | | | | | | 8 | R Reserved. |
| FB | - | 29 | N9 | 45 | | - | - | | Feedback node (regulated output) of DCDC converter. |
| LX | H6 | 31 | N11 | 48 | | - | - | | DCDC converter power stage output. |

Table 3. Pin description...continued

| Symbol | 59 pin VFBGA | 64 pin HTQFP | 98 pin VFBGA | 100 pin HLQFP | | Reset state ^[1] | Type | Function # | Description |
|-----------|--------------|---------------|-----------------|------------------------------------|--------|----------------------------|------|------------|--|
| RESETN | H2 | 21 | J6 | 32 | [7] | - | I | | External reset input: A LOW on this pin resets the device, causing I/O ports and peripherals to take on their default states, and the boot code to execute. Wakes up the part from deep power-down mode. |
| USB0_3V3 | - | 61 | A3 | 96 | | - | - | | USB0 analog 3.3 V supply. |
| USB0_DM | - | 63 | A1 | 98 | [8][6] | | I/O | | USB0 bidirectional D- line. |
| USB0_DP | - | 62 | A2 | 97 | [8][6] | | I/O | | USB0 bidirectional D+ line. |
| USB0_VSS | - | 64 | B1 | 99 | | | | | USB0 analog 3.3 V ground. |
| USB1_DM | J4 | 24 | N6 | 35 | [8][6] | | I/O | | USB1 bidirectional D- line. |
| USB1_DP | H4 | 23 | M6 | 34 | [8][6] | | I/O | | USB1 bidirectional D+ line. |
| USB1_VBUS | G4 | 25 | N8 | 36 | [8][6] | | I | | VBUS pin (power on USB cable). |
| USB1_3V3 | G5 | 27 | N7 | 38 | [9] | - | - | | USB1 analog 3.3 V supply. |
| USB1_VSS | H3 | 22;26 | N5 | 33; 37 | | - | - | | USB1 analog 3.3 V ground. |
| VBAT_DCDC | H7 | 32 | N13 | 49, 50 | [10] | - | - | | Supply of DCDC output stage. DCDC core supply (references and regulation stages). |
| VBAT_PMU | H8 | 33 | M13 | 51 | [10] | - | - | | Analog supply. |
| VDD | F5;E5;D5 | 8; 16; 43; 54 | M1; A5; A9; A13 | 15; 25; 44; 63; 69;75; 84; 95; 100 | | - | - | | Single 1.8 V to 3.6 V power supply powers I/Os. |
| VDD_PMU | G6 | 28 | M9 | 39 | | - | - | | Core supply. For applications with DCDC converter, VDD_PMU and FB are tied at PCB level. |
| VDDA | D3 | 9 | G2 | 16 | | - | - | | Analog supply voltage. At PCB level, has to be tied to main supply (VBAT_PMU, VBAT_DCDC) |
| VREFN | - | - | H1 | 18 | | - | - | | ADC negative reference voltage. |
| VREFP | - | 10 | G1 | 17 | | - | - | | ADC positive reference voltage. |
| VSS | D4;D6;F4;F6 | exposed pad | N1; B5; B9; B13 | exposed pad | | - | - | | Ground. |
| VSS_DCDC | J6 | 30 | N12, M12 | 46, 47 | | - | - | | Star ground connection is managed to PCB ground plane. |
| VSS_PMU | - | - | M11 | - | | - | - | | Star ground connection is managed to PCB ground plane. |
| VSSA | E3 | 11 | H2 | 19 | | - | - | | Analog ground. |

Table 3. Pin description...continued

| Symbol | 59 pin VFBGA | 64 pin HTQFP | 98 pin VFBGA | 100 pin HLQFP | | Reset state ^[1] | Type | Function # | Description |
|-----------|--------------|--------------|--------------|---------------|------|----------------------------|------|------------|--|
| XTAL32K_N | - | 35 | J12 | 53 | [11] | - | - | | RTC oscillator output. |
| XTAL32K_P | - | 34 | J13 | 52 | [11] | - | - | | RTC oscillator input. |
| XTAL32M_N | J1 | 19 | M3 | 28 | [12] | - | - | | Main oscillator output. For USB HS ISP mode, 16 MHz crystal is required. |
| XTAL32M_P | J2 | 20 | N3 | 29 | [12] | - | - | | Main oscillator input. For USB HS ISP mode, 16 MHz crystal is required. |

- [1] PU = input mode, pull-up enabled (pull-up resistor pulls pin up towards V_{DD}). PD = input mode, pull-down enabled (pull-down resistor pulls pin down towards V_{SS}). Z = high impedance; pull-up, pull-down, and input disabled. AI = analog input. I = input. O = output. I/O = input/output. Reset state reflects the pin state at reset without boot code operation. For termination on unused pins, see [Section 6.1.1 "Termination of unused pins"](#).
- [2] Pin providing standard digital I/O functions with configurable modes, configurable hysteresis, and analog input. When configured as an analog input, the digital section of the pin is disabled.
- [3] Pad provides digital I/O functions with TTL levels and hysteresis; normal drive strength.
- [4] The JTAG functions TRST, TCK, TMS, TDI, and TDO are selected by hardware when the part is in boundary scan mode. The JTAG functions cannot be used for debug mode.
- [5] True open-drain pin. I2C-bus pins compliant with the I2C-bus specification for I2C standard mode, I2C Fast-mode, and I2C Fast-mode Plus. The pin requires an external pull-up to provide output functionality. When power is switched off, this pin is floating and does not disturb the I2C lines. Open-drain configuration applies to all functions on this pin. Includes a filter that can be selectively disabled by setting the FILTEROFF bit. The filter suppresses input pulses smaller than about 3 ns in GPIO mode and smaller than about 3 ns in GPIO mode and smaller than 10 ns or 50 ns in I2C mode, depending on the value of I2CFILTER field.
- [6] The corresponding VBUS must be connected to supply voltage when using the USB peripheral. USB0_VBUS is not 5 V tolerant pin and is tolerant up to 3.6 V only when the VDD is at operating level (minimum: 1.8 V). USB1_VBUS is 5 V tolerant pin regardless if the VDD supply is present or not.
- [7] Reset pad with glitch filter and hysteresis. Pulse width of spikes or glitches suppressed by input filter is from 3 ns to 20 ns (simulated value)
- [8] Transparent analog pad.
- [9] If the USB1_3V3 pin is not using the same supply as the VBAT_PMU pin, the application should ensure the supply on USB1_3V3 does not drop below 2.8 V. If the USB1_3V3 pin is using separate supply and this voltage unexpectedly drops below 2.8 V, the USB PHY can go into unknown state causing USB transactions (R/W) to hang. In this case, the application can detect this event with a time-out and would have to recover by performing a USB reset..
- [10] Main battery supply: Star connection at application level (PCB).
- [11] Optional bypass mode is supported, xtal32K_P can be driven by an external clock with restrictions in terms of drive level. See: [Section 13 "Application information"](#).
- [12] Optional bypass mode is supported, xtal32M_P can be driven by an external clock with restrictions in terms of drive level. See: [Section 13 "Application information"](#).

6.1.1 Termination of unused pins

[Table 4](#) shows how to terminate pins that are **not** used in the application. In many cases, unused pins should be connected externally or configured correctly by software to minimize the overall power consumption of the part.

Unused pins with GPIO function should be configured as outputs set to LOW with their internal pull-up disabled. To configure a GPIO pin as output and drive it LOW, select the GPIO function in the IOCON register, select output in the GPIO DIR register, and write a 0 to the GPIO PORT register for that pin. Disable the pull-up in the pin's IOCON register.

In addition, it is recommended to configure all GPIO pins that are not bonded out on smaller packages as outputs driven LOW with their internal pull-up disabled.

Table 4. Termination of unused pins

| Pin | Default state ^[1] | Recommended termination of unused pins |
|-----------------------------|------------------------------|---|
| RESET | I; PU | The RESET pin can be left unconnected if the application does not use it. |
| All PION_m (not open-drain) | I; PU | Can be left unconnected if driven LOW and configured as GPIO output with pull-up or pull-down disabled by software. |

Table 4. Termination of unused pins...continued

| Pin | Default state ^[1] | Recommended termination of unused pins |
|-------------------------|------------------------------|--|
| PIOn_m (I2C open-drain) | IA | Can be left unconnected if driven LOW and configured as GPIO output by software. |
| XTAL32K_P | - | Connect to ground. When grounded, the RTC oscillator is disabled. |
| XTAL32K_N | - | Can be left unconnected. |
| XTAL32M_P | - | Connect to ground. When grounded, the System oscillator is disabled. |
| XTAL32M_N | - | Can be left unconnected. |
| VREFP | - | Tie to VBAT_DCDC. |
| VREFN | - | Tie to VSS. |
| VDDA | - | Tie to VBAT_DCDC. |
| VSSA | - | Tie to VSS. |
| USBn_DP | F | Can be left unconnected. |
| USBn_DM | F | Can be left unconnected. |
| USBn_3V3 | F | Tie to VBAT_DCDC. If not using USB and using 1.8 V supply, USBn_3V3 can be connected to 1.8 V. When not using USB, pin can be connected to ground as well. |
| USB1_VBUS | F | Can be left unconnected. |
| USBn_VSS | F | Tie to VSS. |

[1] I = Input, IA = Inactive (no pull-up/pull-down enabled), PU = Pull-Up enabled

6.1.2 Using Internal DC-DC converter

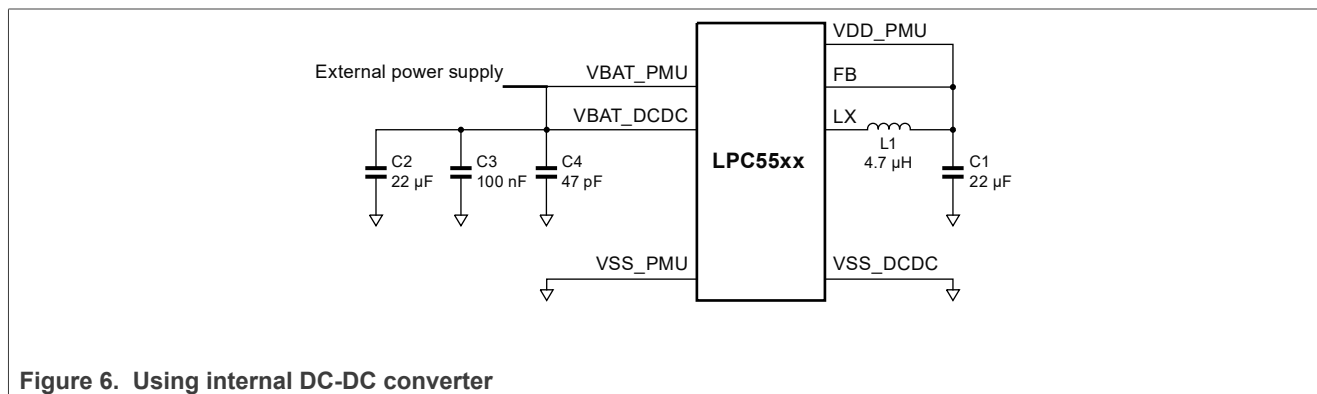

7 Functional description

7.1 Architectural overview

The Arm Cortex M33 includes two AHB-Lite buses, one system bus and one code and bus. The Code AHB (C-AHB) interface is used for any instruction fetch and data access to the Code region of the ARMv8-M memory map ([0x00000000 - 0x1FFFFFFF]). The System AHB (S-AHB) interface is used for instruction fetch and data access to all other regions of the ARMv8-M memory map ([0x20000000 - 0xFFFFFFFF]).

The LPC55S6x uses a multi-layer AHB matrix to connect the ARM Cortex-M33 buses and other bus masters to peripherals in a flexible manner that optimizes performance by allowing peripherals that are on different slave ports of the matrix to be accessed simultaneously by different bus masters. [Figure 5](#) shows details of the available matrix connections.

7.2 Arm Cortex-M33 processor (CPU0)

The ARM Cortex-M33 is based on the ARMv8-M architecture that offers systems enhancements, such as ARM TrustZone® security, single-cycle digital signal processing, low power consumption, enhanced debug features, and a high level of support block integration. The ARM Cortex-M33 CPU employs a 7-stage instruction pipe and includes an internal prefetch unit that supports speculative branching. A hardware floating-point processor is integrated into the core. On the LPC55S6x, the Cortex-M33 is augmented with two hardware co-processors providing accelerated support for additional DSP algorithms and cryptography.

The Arm Cortex M33 provides a security foundation, offering isolation to protect valuable IP and data with TrustZone technology. It simplifies the design and software development of digital signal control systems with the integrated digital signal processing (DSP) instructions.

7.3 Arm Cortex-M33 integrated Floating Point Unit (FPU)

The FPU fully supports single-precision add, subtract, multiply, divide, multiply and accumulate, and square root operations. It also provides conversions between fixed-point and floating-point data formats, and floating-point constant instructions.

The FPU provides floating-point computation functionality that is compliant with the ANSI/IEEE Std 754-2008, IEEE Standard for Binary Floating-Point Arithmetic, referred to as the IEEE 754 standard.

7.4 Arm Cortex-M33 (CPU1)

The LPC55S6x device includes a second instance of Cortex-M33. The configuration of this instance does not include MPU, FPU, DSP, ETM, Trustzone (SEEXT), Secure Attribution Unit (SAU) or co-processor interface. It supports the same debug levels and interrupt lines as the primary CPU.

7.5 Memory Protection Unit (MPU)

The Cortex-M33 includes a Memory Protection Unit (MPU) which can be used to improve the reliability of an embedded system by protecting critical data within the user application.

The MPU allows separating processing tasks by disallowing access to each other's data, disabling access to memory regions, allowing memory regions to be defined as read-only and detecting unexpected memory accesses that could potentially break the system.

The MPU separates the memory into distinct regions and implements protection by preventing disallowed accesses. The MPU supports up to eight regions each of which can be divided into eight subregions. Accesses to memory locations that are not defined in the MPU regions, or not permitted by the region setting, will cause the Memory Management Fault exception to take place.

7.6 Nested Vectored Interrupt Controller (NVIC) for Cortex-M33 (CPU0)

The NVIC is an integral part of the Cortex-M33. The tight coupling to the CPU allows for low interrupt latency and efficient processing of late arriving interrupts.

7.6.1 Features

- Controls system exceptions and peripheral interrupts.

- 60 vectored interrupts.
- Eight programmable interrupt priority levels, with hardware priority level masking.
- Relocatable vector table using Vector Table Offset Register (VTOR).
- Non-Maskable Interrupt (NMI).
- Software interrupt generation.

7.6.2 Interrupt sources

Each peripheral device has one interrupt line connected to the NVIC but may have several interrupt flags.

7.7 Nested Vectored Interrupt Controller (NVIC) for Cortex-M33 (CPU1)

The NVIC is an integral part of the Cortex-M33. The tight coupling to the CPU allows for low interrupt latency and efficient processing of late arriving interrupts.

7.7.1 Features

- Controls system exceptions and peripheral interrupts.
- 60 vectored interrupts.
- Four programmable interrupt priority levels, with hardware priority level masking.
- Relocatable vector table using VTOR.
- Non-Maskable Interrupt (NMI).
- Software interrupt generation.

7.7.2 Interrupt sources

Each peripheral device has one interrupt line connected to the NVIC but may have several interrupt flags.

7.8 System Tick timer (SysTick)

The ARM Cortex-M33 core include a system tick timer (SysTick) that is intended to generate a dedicated SYSTICK exception. The clock source for the SysTick can be the system clock or the SYSTICK clock.

7.9 On-chip static RAM

The LPC55S6x support up to 320 KB SRAM with separate bus master access for higher throughput and individual power control for low-power operation.

7.10 On-chip flash

The LPC55S6x supports up to 640 kB of on-chip flash memory. The last 17 pages (10 KB) are reserved on the 640 KB flash devices resulting in 630 KB internal flash memory.

7.11 On-chip ROM

The on-chip ROM contains the bootloader and the following features:

- Booting of images from on-chip flash.
- Supports CRC32 image integrity checking.
- Supports flash programming through In System Programming (ISP) commands over following interfaces: USB0/1 interfaces using HID Class device, UART interface (Flexcomm 0) with auto baud, SPI slave interfaces (Flexcomm 3 or 9) using mode 3 (CPOL = 1 and CPHA = 1), and I2C slave interface (Flexcomm 1)

- ROM API functions: Flash programming API, Power control API, and Secure firmware update API using NXP Secure Boot file format, version 2.0 (SB2 files).
- Supports booting of images from PRINCE encrypted flash region.
- Supports NXP Debug Authentication Protocol version 1.0 (RSA-2048) and 1.1 (RSA-4096)
- Supports setting a sealed part to Fault Analysis mode through Debug authentication.

The on-chip ROM supports the following secure boot features:

- Uses RSASSA-PKCS1-v1_5 signature of SHA256 digest as cryptographic signature verification
- Supports RSA-2048 bit public keys (2048 bit modulus, 32-bit exponent)
- Supports RSA-4096 bit public keys (4096 bit modulus, 32-bit exponent)
- Uses x509 certificate format to validate image public keys
- Supports up to four revocable Root of Trust (or Certificate Authority) keys, Root of Trust (RoT) establishment by storing the SHA-256 hash digest of the hashes of four RoT public keys in protected flash region (PFR)
- Supports anti-rollback feature using image key revocation and supports up to 16 Image key certificates revocations using Serial Number field in x509 certificate.
- Supports Device Identifier Composition Engine (DICE) Specification (version Family 2.0, Level 00 Revision 69) specified by Trusted Computing Group.

7.12 Protected Flash Region (PFR)

The protected flash region is available to configure secure boot, debug authentication, read UUID, store PUF in key store area, and user defined fields available for specific data storage.

7.13 Memory mapping

7.14 AHB multilayer matrix

The LPC55S6x uses a multi-layer AHB matrix to connect the CPU buses and other bus masters to peripherals in a flexible manner that optimizes performance by allowing peripherals that are on different slave ports of the matrix to be accessed simultaneously by different bus masters. The device block diagram in [Figure 5](#) shows details of the available matrix connections.

7.15 Memory Protection Unit (MPU)

CPU0 has a memory protection unit (MPU) that provides fine grain memory control, enabling applications to implement security privilege levels, separating code, data and stack on a task-by-task basis. Such requirements are critical in many embedded applications.

The MPU register interface is located on the CPU private peripheral bus and is described in detail in Ref 1 "Cortex-M33 DEBUG"

7.16 TrustZone and system mapping on this device

The implementation of ARM TrustZone for CPU0 involves using address bit 28 to divide the address space into potential secure and non-secure regions. Address bit 28 is not decoded in memory access hardware, so each physical location appears in two places on whatever bus they are located on. Other hardware determines which kinds of accesses (including non-secure callable) are actually allowed for any particular address.

[Table 5](#) shows the overall mapping of the code and data buses for secure and non-secure accesses to various device resources.

Remark: Address regions considered secure by TrustZone may also be accessible to CPU1 if it is assigned as a secure master and marked as secure by checker hardware.

Remark: In the peripheral description chapters of this manual, only the native (non-secure) base address is noted, secure base addresses can be found in this chapter or created by setting bit 28 in the address as needed.

Table 5. TrustZone and system general mapping

| Start address | End address | TrustZone, CPU0 only | CPU bus | CM-33 usage (both CPUs) |
|---------------|-------------|----------------------|---------|---|
| 0x0000 0000 | 0x0FFF FFFF | Non-secure | Code | Flash memory, Boot ROM, SRAM X. |
| 0x1000 0000 | 0x1FFF FFFF | Secure | Code | Same as above. |
| 0x2000 0000 | 0x2FFF FFFF | Non-secure | Data | SRAM 0, SRAM 1, SRAM 2, SRAM 3, SRAM 4. |
| 0x3000 0000 | 0x3FFF FFFF | Secure | Data | Same as above. |
| 0x4000 0000 | 0x4FFF FFFF | Non-secure | Data | AHB and APB peripherals. |
| 0x5000 0000 | 0x5FFF FFFF | Secure | Data | Same as above. |

1. The size shown for peripherals spaces indicates the space allocated in the memory map, not the actual space used by the peripheral or memory.
2. Selected areas of secure regions may be marked as non-secure callable.

7.17 Links to specific memory map descriptions and tables:

- [Section 7.18](#)
- [Section 7.19](#)
- [Section 7.20](#)

7.18 Memory map overview

[Table 6](#) gives a more detailed memory map as seen by the 2 Cortex-M33 (both CPU0 and CPU1). The purpose of the four address spaces for the shared RAMs is outlined at the beginning of this chapter. The details of which shared RAM regions are on which AHB matrix slave ports can be seen here.

Table 6. Memory map overview

| AHB port | Non-secure start address | Non-secure end address | Secure start address | Secure end address | Function ^[1] |
|----------|--------------------------|------------------------|----------------------|--------------------|---|
| 0 | 0x0000 0000 | 0x0009 FFFF | 0x1000 0000 | 0x1009 FFFF | Flash memory, on CM33 code bus. The last 17 pages (10 KB) are reserved on the 640 KB flash devices resulting in 630 KB internal flash memory. |
| | 0x0300 0000 | 0x0301 FFFF | 0x1300 0000 | 0x1301 FFFF | Boot ROM, on CM33 code bus. |
| 1 | 0x0400 0000 | 0x0400 7FFF | 0x1400 0000 | 0x1400 7FFF | SRAM X on CM33 code bus, 32 KB. SRAMX_0 (0x1400 0000 to 0x1400 0FFF) and SRAMX_1 (0x1400 4000 to 0x1400 4FFF) are used for Casper (total 8 KB). If CPU retention used in power-down mode, SRAMX_2 (0x1400 6000 to 0x1400 65FF) is used (total 1.5 KB) by default in power API and this is user configurable within SRAMX_2 and SRAMX_3. |
| 2 | 0x2000 0000 | 0x2000 FFFF | 0x3000 0000 | 0x3000 FFFF | SRAM 0 on CM33 data bus, 64 KB. |
| 3 | 0x2001 0000 | 0x2001 FFFF | 0x3001 0000 | 0x3001 FFFF | SRAM 1 on CM33 data bus, 64 KB. |
| 4 | 0x2002 0000 | 0x2002 FFFF | 0x3002 0000 | 0x3002 FFFF | SRAM 2 on CM33 data bus, 64 KB. |
| 5 | 0x2003 0000 | 0x2003 FFFF | 0x3003 0000 | 0x3003 FFFF | SRAM 3 on CM33 data bus, 64 KB. |

Table 6. Memory map overview...continued

| AHB port | Non-secure start address | Non-secure end address | Secure start address | Secure end address | Function ^[1] |
|----------|--------------------------|------------------------|----------------------|--------------------|---|
| 6 | 0x2004 0000 | 0x2004 3FFF | 0x3004 0000 | 0x3004 3FFF | SRAM 4 on CM33 data bus, 16 KB. Entire SRAM 4 is used by PowerQuad when PowerQuad is enabled. |
| 7 | 0x4000 0000 | 0x4001 FFFF | 0x5000 0000 | 0x5001 FFFF | AHB to APB bridge 0. See Section 7.19 . |
| | 0x4002 0000 | 0x4003 FFFF | 0x5002 0000 | 0x5003 FFFF | AHB to APB bridge 1. See Section 7.19 . |
| 8 | 0x4008 0000 | 0x4008 FFFF | 0x5008 0000 | 0x5008 FFFF | AHB peripherals. See Section 7.20 . |
| 9 | 0x4009 0000 | 0x4009 FFFF | 0x5009 0000 | 0x5009 FFFF | AHB peripherals. See Section 7.20 . |
| 10 | 0x400A 0000 | 0x400A FFFF | 0x500A 0000 | 0x500A FFFF | AHB peripherals. See Section 7.20 . |
| 11 | 0x4010 0000 | 0x4010 FFFF | 0x5010 0000 | 0x5010 FFFF | AHB peripherals. See Section 7.20 . |

[1] Gaps between AHB matrix slave ports are not shown.

7.19 APB peripherals

[Table 7](#) provides details of the addresses for APB peripherals. APB peripherals have both secure and non-secure access possibilities.

Table 7. APB peripherals memory map

| APB bridge | Non-secure base address | Secure base address | Peripheral |
|------------|-------------------------|---------------------|--|
| 0 | 0x4000 0000 | 0x5000 0000 | Syscon. |
| | 0x4000 1000 | 0x5000 1000 | IOCON. Pin function selection and pin control setup. |
| | 0x4000 2000 | 0x5000 2000 | Group GPIO input interrupt 0 (GINT0) |
| | 0x4000 3000 | 0x5000 3000 | Group GPIO input interrupt 1 (GINT1) |
| | 0x4000 4000 | 0x5000 4000 | Pin interrupt and pattern match (PINT) |
| | 0x4000 5000 | 0x5000 5000 | Secure pin interrupt and pattern match. |
| | 0x4000 6000 | 0x5000 6000 | Input multiplexing 0 and frequency measure. |
| | 0x4000 7000 | 0x5000 7000 | Reserved. |
| | 0x4000 8000 | 0x5000 8000 | CT32B0 (standard counter/timer 0). |
| | 0x4000 9000 | 0x5000 9000 | CT32B1 (standard counter/timer 1). |
| | 0x4000 C000 | 0x5000 C000 | WWDTO (windowed watchdog timer 0). |
| | 0x4000 D000 | 0x5000 D000 | MRT (Multi-Rate Timer). |
| | 0x4000 E000 | 0x5000 E000 | Utick (micro-tick timer). |
| | 0x4001 0000 | 0x5001 0000 | ACMP0 (analog comparator). |
| | 0x4001 3000 | 0x5001 3000 | Analog controls. |
| | 0x4001 5000 | 0x5001 5000 | Reserved. |
| 1 | 0x4002 3000 | 0x5002 3000 | Sysctl (I2S signal sharing) |
| | 0x4002 8000 | 0x5002 8000 | CT32B2 (standard counter/timer 2). |
| | 0x4002 9000 | 0x5002 9000 | CT32B3 (standard counter/timer 3). |
| | 0x4002 A000 | 0x5002 A000 | CT32B4 (standard counter/timer 4). |

Table 7. APB peripherals memory map...continued

| APB bridge | Non-secure base address | Secure base address | Peripheral |
|------------|-------------------------|---------------------|-------------------------------------|
| | 0x4002 C000 | 0x5002 C000 | RTC & Wake-up timer. |
| | 0x4002 D000 | 0x5002 D000 | OS_Event Timer. |
| | 0x4003 4000 | 0x5003 4000 | Flash controller. |
| | 0x4003 5000 | 0x5003 5000 | PRINCE dynamic encrypt/decrypt |
| | 0x4003 8000 | 0x5003 8000 | USB HS Phy. |
| | 0x4003 A000 | 0x5003 A000 | True Random Number Generator. |
| | 0x4003 B000 | 0x5003 B000 | PUF (Physical Unclonable Function). |
| | 0x4003 D000 | 0x5003 D000 | PLU (Programmable Logic Unit). |

7.20 AHB peripherals

[Table 8](#) provides details of the addresses for AHB peripherals. AHB peripherals have both secure and non-secure access possibilities.

Table 8. AHB peripheral memory map

| AHB port | Non-secure base address | Secure base address | Peripheral |
|----------|-------------------------|---------------------|--------------------------|
| 8 | 0x4008 2000 | 0x5008 2000 | DMA0 registers. |
| | 0x4008 4000 | 0x5008 4000 | FS USB Device registers. |
| | 0x4008 5000 | 0x5008 5000 | SCTimer/PWM. |
| | 0x4008 6000 | 0x5008 6000 | Flexcomm Interface 0. |
| | 0x4008 7000 | 0x5008 7000 | Flexcomm Interface 1. |
| | 0x4008 8000 | 0x5008 8000 | Flexcomm Interface 2. |
| | 0x4008 9000 | 0x5008 9000 | Flexcomm Interface 3. |
| | 0x4008 A000 | 0x5008 A000 | Flexcomm Interface 4. |
| | 0x4008 B000 | 0x5008 B000 | Inter-CPU Mailbox. |
| | 0x4008 C000 | 0x5008 C000 | High Speed GPIO. |
| 9 | 0x4009 4000 | 0x5009 4000 | HS USB device registers. |
| | 0x4009 5000 | 0x5009 5000 | CRC Engine. |
| | 0x4009 6000 | 0x5009 6000 | Flexcomm Interface 5. |
| | 0x4009 7000 | 0x5009 7000 | Flexcomm Interface 6. |
| | 0x4009 8000 | 0x5009 8000 | Flexcomm Interface 7. |
| | 0x4009 B000 | 0x5009 B000 | SDIO registers. |
| | 0x4009 C000 | 0x5009 C000 | Debug Mailbox (DM-AP). |
| | 0x4009 F000 | 0x5009 F000 | High Speed SPI. |
| 10 | 0x400A 0000 | 0x500A 0000 | ADC0. |
| | 0x400A 2000 | 0x500A 2000 | FS USB Host registers. |
| | 0x400A 3000 | 0x500A 3000 | HS USB Host registers. |

Table 8. AHB peripheral memory map...continued

| AHB port | Non-secure base address | Secure base address | Peripheral |
|----------|-------------------------|---------------------|-----------------------------|
| | 0x400A 4000 | 0x500A 4000 | Hash-AES registers. |
| | 0x400A 5000 | 0x500A 5000 | Casper |
| | 0x400A 6000 | 0x500A 6000 | PowerQuad |
| | 0x400A 7000 | 0x500A 7000 | DMA1 registers. |
| | 0x400A 8000 | 0x500A 8000 | Secure HS GPIO. |
| | 0x400A C000 | 0x500A C000 | Security Control registers. |
| 11 | 0x4010 0000 | 0x5010 0000 | USB SRAM. |

7.21 RAM configuration

[Table 9](#) describes the RAM configuration for the LPC55S6x.

Table 9. RAM Configuration

| RAM Total | RAM-X (KB) | RAM0 (KB) | RAM1 (KB) | RAM2 (KB) | RAM3 (KB) | RAM4 (KB) | USB-RAM (KB) |
|----------------|------------|-----------|-----------|-----------|-----------|-----------|--------------|
| 320 KB devices | 32 | 64 | 64 | 64 | 64 | 16 | 16 |
| 256 KB devices | 32 | 64 | 64 | 64 | - | 16 | 16 |
| 144 KB devices | 32 | 64 | 32 | - | - | - | 16 |

7.22 System control

7.22.1 Clock sources

The LPC55S6x supports 2 external and 3 internal clock sources:

- Internal Free Running Oscillator (FRO). This oscillator provides a selectable 96 MHz output, and a 12 MHz output (divided down from the selected higher frequency) that can be used as a system clock. The FRO is trimmed to +/- 2% accuracy over the entire voltage and -40 C to 105 C. For devices with date code 2041 (yyww) and onwards, the FRO is trimmed to +/- 1% accuracy over the entire voltage and 0 C to 85 C. The FRO 12 MHz oscillator provides the default clock at reset and provides a clean system clock shortly after the supply pins reach operating voltage.
- 32 kHz Internal Free Running Oscillator FRO. The FRO is trimmed to +/- 2% accuracy over the entire voltage and temperature range.
Internal low power oscillator (FRO 1 MHz). The FRO is trimmed to +/- 15% accuracy over the entire voltage and temperature range.
- Crystal oscillator with an operating frequency of 16 MHz to 32 MHz. Option for external clock input (bypass mode) for clock frequencies of up to 25 MHz
Crystal oscillator with 32.768 KHz operating frequency. Option for external clock input (bypass mode) for clock frequencies of up to 100 kHz
- Each crystal oscillator has one embedded capacitor bank which can be used as an integrated load capacitor. Using APIs, the capacitor banks on each crystal pin can tune the frequency for crystals with a Capacitive Load (CL) which conserves board space and reduces costs.

7.22.2 PLL (PLL0 and PLL1)

PLL0 and PLL1 allows CPU operation up to the maximum CPU rate without the need for a high-frequency external clock. PLL0 and PLL1 can run from the internal FRO 12 MHz output, the external oscillator, internal FRO 1 MHz output, or the 32.768 KHz RTC oscillator.

The system PLL accepts an input clock frequency in the range of 2 kHz - 150 MHz. The input frequency is multiplied up to a high frequency with a Current Controlled Oscillator (CCO). The PLL can be enabled or disabled by software.

7.22.3 Clock generation

The system control block facilitates the clock generation. Many clocking variations are possible. [Figure 7](#) gives an overview of potential clock options. [Table 10](#) describes signals on the clocking diagram. The maximum clock frequency is 150 MHz.

Remark: The indicated clock multiplexers shown in [Figure 7](#) are synchronized. In order to operate, the currently selected clock must be running, and the clock to be switched to must also be running. This is so that the multiplexer can gracefully switch between the two clocks without glitches. Other clock multiplexers are not synchronized. The output divider can be stopped and restarted gracefully during switching if a glitch-free output is needed.

The low-power oscillator provides a frequency in the range of 1 MHz. The accuracy of this clock is limited to +/- 15% over temperature, voltage, and silicon processing variations after trimming made during assembly. To determine the actual watchdog oscillator output, use the frequency measure block.

The part contains one system PLL that can be configured to use a number of clock inputs and produce an output clock in the range of 1.2 MHz up to the maximum chip frequency, and can be used to run most on-chip functions. The output of the PLL can be monitored through the CLKOUT pin.

Table 10. Clocking diagram signal name descriptions

| Name | Description |
|----------|--|
| 32k_osc | The 32 kHz output of the RTC oscillator. The 32 kHz clock must be enabled in the RTCOSCCTRL register. |
| clk_in | This is the internal clock that comes from the external oscillator. |
| frg_clk | The output of each Fractional Rate Generator to Flexcomm clock. Each FRG and its source selection is shown in Figure 7 . |
| fro_12m | 12 MHz divided down from the currently selected on-chip FRO oscillator. |
| fro_hf | The currently selected FRO high speed output at 96 MHz. |
| main_clk | The main clock used by the CPU and AHB bus, and potentially many others. The main clock and its source selection are shown in Figure 7 . |
| mclk_in | The MCLK input function, when it is connected to a pin by selecting it in the IOCON block. |
| pll0_clk | The output of the PLL0. The PLL0 and its source selection is shown in Figure 7 . |
| pll1_clk | The output of the PLL1. The PLL1 and its source selection is shown in Figure 7 . |
| fro_1m | The output of the low power oscillator. |
| "none" | A tied-off source that should be selected to save power when the output of the related multiplexer is not used. |

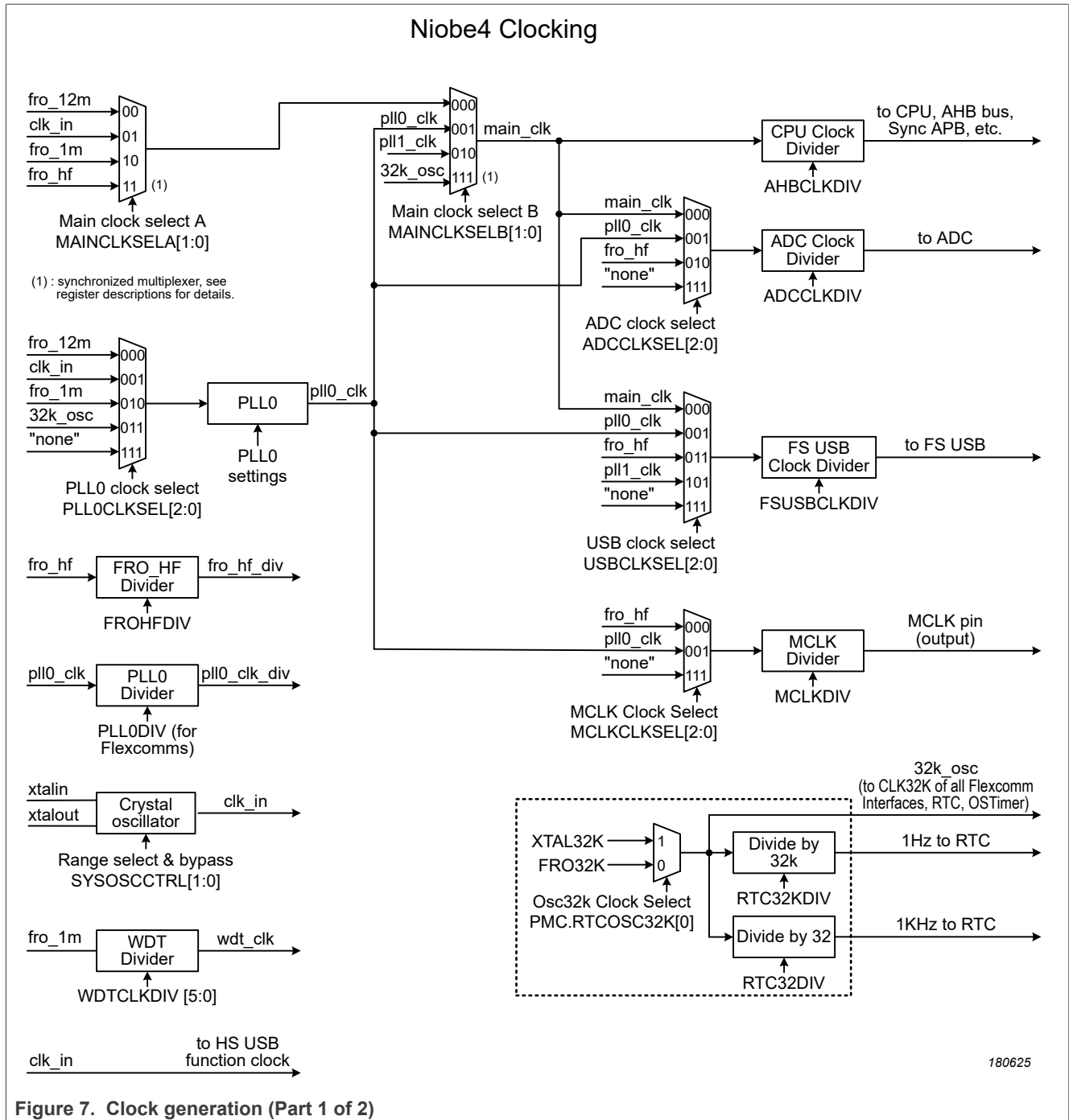

Niobe4 Clocking, page 2

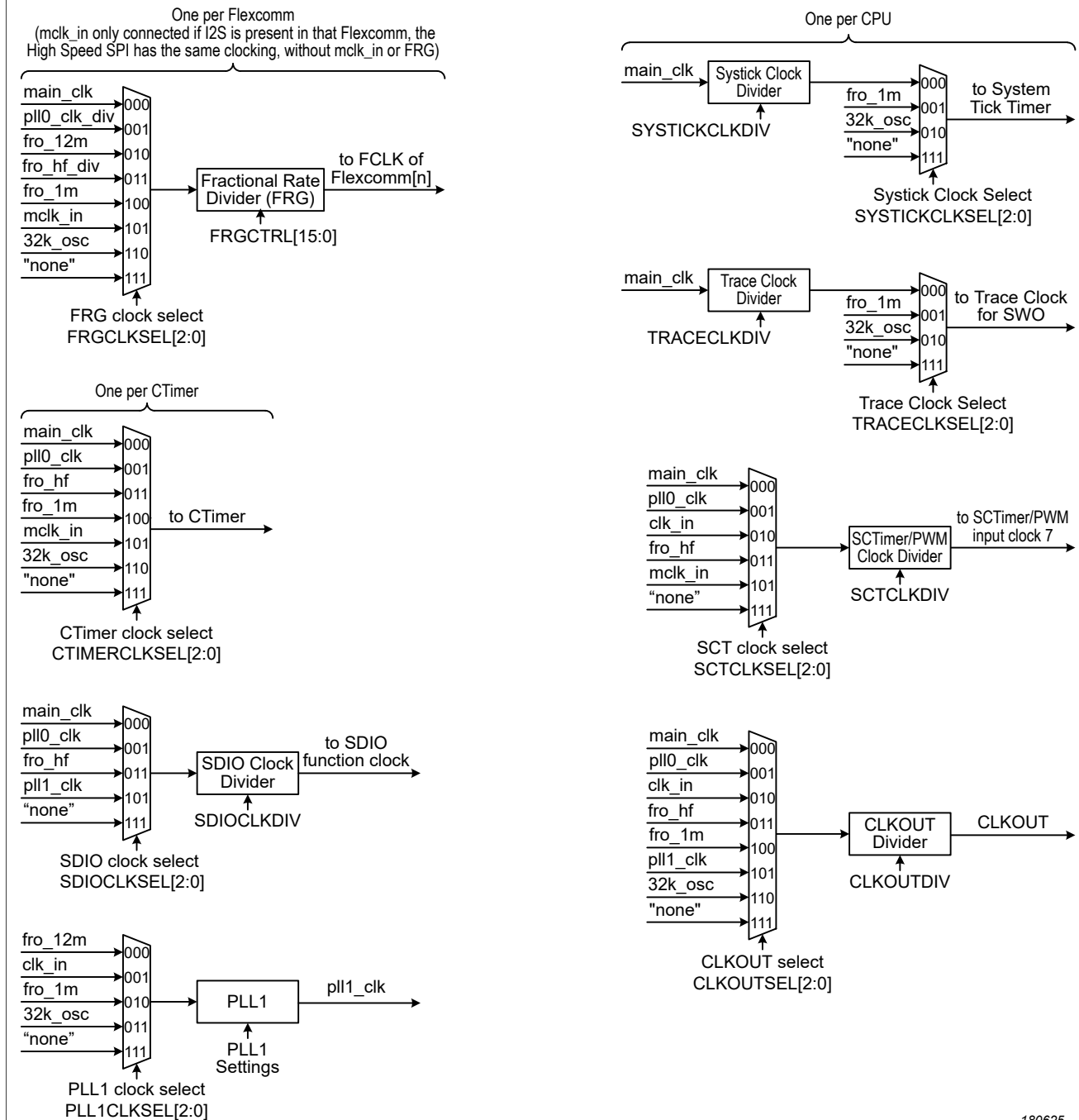

Figure 8. Clock generation (Part 2 of 2)

7.22.4 Brownout detection

The LPC55S6x includes one Brown-out detector to monitor the voltage of VBAT. If the voltage falls below one of the selected voltages, the BOD asserts an interrupt to the NVIC or issues a reset.

7.23 Power control

The LPC55S6x support a variety of power control features. In Active mode, when the chip is running, power and clocks to selected peripherals can be adjusted for power consumption. In addition, there are four special modes of processor power reduction with different peripherals running: sleep mode, deep-sleep mode, power-down mode, and deep power-down mode which can be activated by the power mode configure API.

7.23.1 Sleep mode

In sleep mode, the system clock to both CPUs (CPU0 and CPU1) are stopped and execution of instructions is suspended until either a reset or interrupt occurs. Peripheral functions, if selected to be clocked can continue operation during sleep mode and may generate interrupts to cause the processor to resume execution. Sleep mode eliminates dynamic power used by the processor itself, memory systems and related controllers, internal buses, and unused peripherals.

7.23.2 Deep-sleep mode

In deep-sleep mode, the flash is powered down. The system clock to both CPUs (CPU0 and CPU1) are stopped and if not configured, the peripherals receives no clocks. Through the power profiles API, selected peripherals such as USB0, USB1, Flexcomm interfaces 0 to 7 (SPI, I2C, USART, I2S), Flexcomm interface 10 (High Speed SPI), Micro-tick, WWDT, RTC, OSTimer, Standard Timers, comparator, and BOD can be left running in deep-sleep mode. Clock sources such as FRO12 MHz, FRO 32 KHz, FRO 1 MHz, the 32.768 kHz RTC clock, and the external oscillator can be enabled or disabled via software.

The LPC55S6x can wake up from deep-sleep mode via a reset, digital pins selected as inputs to the pin interrupt block and group interrupt block, OS Timer, Standard Timers, Micro-tick, RTC alarm, a watchdog timer interrupt/reset, BOD interrupt/reset, an interrupt from the USB0, USB1, SPI, I2C, I2S, USART, comparator, and PLU. Some peripherals can have DMA service during deep-sleep mode without waking up entire device.

In deep-sleep mode, all SRAM, GPIO logic state, and registers maintain their internal states. All SRAM instances that are not configured to enter in 'retention state' will stay in active state. Deep-sleep mode allows for very low quiescent power and fast wake-up options.

7.23.3 Power-down mode

In power-down mode, nearly all on-chip power consumption is turned off by shutting down the internal DC-DC converter. The flash is powered down. The system clock to both CPUs (CPU0 and CPU1) are stopped and if not configured, the peripherals receives no clocks. Through the power profiles API, selected peripherals such as Flexcomm interfaces 3 (SPI, I2C, USART, I2S), RTC, OS Timer, and comparator can be left running in power-down mode. Clock sources such as FRO 32 KHz, and the 32.768 kHz RTC clock can be enabled or disabled via software.

The LPC55S6x can wake up from power-down mode via a reset, digital pins selected as inputs to the group interrupt block, OS Timer, RTC alarm, an interrupt from the Flexcomm Interface 3 (SPI, I2C, I2S, USART), and comparator.

In power-down mode, the CPU0 processor state is retained to allow resumption of code execution when a wake-up event occurs.

All SRAM can be configured to maintain their internal state as long as it is configured to do so using power API call. The GPIO logic level does not remain static in power-down mode. All GPIO pin state will be logic '0' in power-down mode.

All IOCON registers and peripheral registers related ONLY to Flexcomm3 (SPI, I2C, I2S, USART), GINTO0, RTC, OS Event timer, and analog comparator will maintain state in power-down mode.

7.23.4 Deep power-down mode

In deep power-down mode, power is shut off to the entire chip except for the RTC power domain, the $\overline{\text{RESET}}$ pin, 4 Wake-up pins, and the OT Timer if enabled. Clock sources such as FRO 32 KHz, and the 32.768 kHz RTC clock can be enabled or disabled via software. The LPC55S6x can wake up from deep power-down mode via the $\overline{\text{RESET}}$ pin, the RTC alarm, four special wake-up pins, or without an external signal, by using the time-out of the OS Timer. The ALARM1HZ flag in RTC control register generates an RTC wake-up interrupt request, which can wake up the part. SRAM can maintain their internal states. All SRAM instances that are not configured to enter in 'retention state' will stay in active state. In deep power-down mode all functional pins are in tri-state.

7.24 General Purpose I/O (GPIO)

The LPC55S6x provide GPIO ports 0 and 1 with a total of 64 GPIO pins.

Device pins that are not connected to a specific peripheral function are controlled by the GPIO registers. Pins may be dynamically configured as inputs or outputs. Separate registers allow setting or clearing any number of outputs simultaneously. The current level of a port pin can be read back no matter what peripheral is selected for that pin.

See [Table 3](#) for the default state on reset.

7.24.1 Features

- Accelerated GPIO functions:
 - GPIO registers are located on the AHB so that the fastest possible I/O timing can be achieved.
 - Mask registers allow treating sets of port bits as a group, leaving other bits unchanged.
 - All GPIO registers are byte and half-word addressable.
 - Entire port value can be written in one instruction.
- Bit-level set, clear, and toggle registers allow a single instruction set, clear or toggle of any number of bits in one port.
- Direction control of individual bits.
- All I/O default to inputs after reset.
- All GPIO pins can be selected to create an edge or level-sensitive GPIO interrupt request.
- Two GPIO group interrupts can be triggered by a combination of any pin or pins to reflect two distinct interrupt patterns.
- The grouped interrupts can wake up the part from sleep, deep-sleep, and power-down modes.

7.25 Pin interrupt/pattern engine

The pin interrupt block configures up to eight pins from all digital pins for providing eight external interrupts connected to the NVIC. The pattern match engine can be used in conjunction with software to create complex state machines based on pin inputs. Any digital pin, independent of the function selected through the switch matrix can be configured through the SYSCON block as an input to the pin interrupt or pattern match engine. The registers that control the pin interrupt or pattern match engine are located on the I/O+ bus for fast single-cycle access.

7.25.1 Features

- Pin interrupts:
 - Up to eight pins can be selected from all GPIO pins on ports 0 and 1 as edge-sensitive or level-sensitive interrupt requests. Each request creates a separate interrupt in the NVIC.
 - Edge-sensitive interrupt pins can interrupt on rising or falling edges or both.

- Level-sensitive interrupt pins can be HIGH-active or LOW-active.
- Level-sensitive interrupt pins can be HIGH-active or LOW-active.
- Pin interrupts can wake up the device from sleep mode, and deep-sleep mode.
- Pattern match engine:
 - Up to eight pins can be selected from all digital pins on ports 0 and 1 to contribute to a boolean expression. The boolean expression consists of specified levels and/or transitions on various combinations of these pins.
 - Each bit slice minterm (product term) comprising of the specified boolean expression can generate its own, dedicated interrupt request.
 - Any occurrence of a pattern match can also be programmed to generate an RXEV notification to the CPU. The RXEV signal can be connected to a pin.
 - Pattern match can be used in conjunction with software to create complex state machines based on pin inputs.
 - Pattern match engine facilities wake-up only from active and sleep modes.

7.26 Communication peripherals

7.26.1 Full-speed USB Host/Device Interface (USB0)

The USB is a 4-wire bus that supports communication between a host and one or more (up to 127) peripherals. The host controller allocates the USB bandwidth to attached devices through a token-based protocol. The bus supports hot plugging and dynamic configuration of the devices. All transactions are initiated by the host controller.

7.26.1.1 USB0 device controller

The device controller enables 12 Mbit/s data exchange with a USB host controller. It consists of a register interface, serial interface engine, endpoint buffer memory. The serial interface engine decodes the USB data stream and writes data to the appropriate endpoint buffer. The status of a completed USB transfer or error condition is indicated via status registers. An interrupt is also generated if enabled.

Features

- USB2.0 full-speed device controller supporting crystal-less operation in device mode using software library example in technical note (TN00063).
- Supports ten physical (five logical) endpoints including one control endpoint.
- Single and double-buffering supported.
- Each non-control endpoint supports bulk, interrupt, or isochronous endpoint types.
- Supports wake-up from Deep-sleep mode on USB activity and remote wake-up.
- Supports SoftConnect.
- Link Power Management (LPM) supported.

7.26.1.2 USB0 host controller

The host controller enables full- and low-speed data exchange with USB devices attached to the bus. It consists of register interface, serial interface engine and DMA controller. The register interface complies with the Open Host Controller Interface (OHCI) specification.

Features

- OHCI compliant.
- Two downstream ports.

7.26.2 High-Speed USB Host/Device Interface (USB1)

The Universal Serial Bus (USB) is a 4-wire bus that supports communication between a host and one or more (up to 127) peripherals. The host controller allocates the USB bandwidth to attached devices through a token-based protocol. The bus supports hot plugging and dynamic configuration of the devices. All transactions are initiated by the host controller.

7.26.2.1 USB1 device controller

The device controller enables 480 Mbit/s data exchange with a USB host controller. It consists of a register interface, serial interface engine, endpoint buffer memory. The serial interface engine decodes the USB data stream and writes data to the appropriate endpoint buffer. The status of a completed USB transfer or error condition is indicated via status registers. An interrupt is also generated if enabled.

Features

- Fully compliant with USB 2.0 Specification (high speed).
- Supports 12 physical (6 logical) endpoints with up to 8 kB endpoint buffer RAM.
- Supports Control, Bulk, Interrupt and Isochronous endpoints.
- Scalable realization of endpoints at run time.
- Endpoint Maximum packet size selection (up to USB maximum specification) by software at run time.
- While USB is in the Suspend mode, the LPC55S6x can enter deep-sleep mode and wake up on USB activity.
- Double buffer implementation for Bulk and Isochronous endpoints

7.26.2.2 USB1 host controller

The host controller enables high speed data exchange with USB devices attached to the bus. It consists of register interface and serial interface engine. The register interface complies with the Enhanced Host Controller Interface (EHCI) specification

Features

- EHCI compliant.
- Two downstream ports.
- Supports per-port power switching.

7.26.3 Flexcomm Interface serial communication

Each Flexcomm Interface provides a choice of peripheral functions, one of which must be chosen by the user before the function can be configured and used.

7.26.3.1 Features

- USART with asynchronous operation or synchronous master or slave operation.
- SPI master or slave with up to 4 slave selects.
- I²C, including separate master, slave, and monitor functions.
- Flexcomm interfaces 0 to 7 each provide one channel pair of I²S.
- Data for USART, SPI, and I2S traffic uses the Flexcomm FIFO. The I²C function does not use the FIFO.

7.26.3.2 SPI serial I/O (SPIO) controller

Features

- Maximum supported bit rate for SPI master mode (transmit/receive) is 32 Mbit/s. The maximum supported bit rate for SPI slave receive mode is 25 Mbit/s and for SPI slave transmit mode is 16 Mbit/s.
- Master and slave operation.
- Data frames of 4 to 16 bits supported directly. Larger frames supported by software.
- The SPI function supports separate transmit and receive FIFOs with eight entries each.
- Supports DMA transfers: SPI transmit and receive functions can be operated with the system DMA controller.
- Data can be transmitted to a slave without the need to read incoming data. This can be useful while setting up an SPI memory.
- Up to Four Slave Select input/outputs with selectable polarity and flexible usage.

7.26.3.3 I²C-bus interface

The I²C-bus is bidirectional for inter-IC control using only two wires: a serial clock line (SCL) and a serial data line (SDA). Each device is recognized by a unique address and can operate as either a receiver-only device (for example, an LCD driver) or a transmitter with the capability to both receive and send information (such as memory). Transmitters and/or receivers can operate in either master or slave mode, depending on whether the chip has to initiate a data transfer or is only addressed. The I²C is a multi-master bus and can be controlled by more than one bus master connected to it.

Features

- Support standard, Fast-mode, and Fast-mode Plus (specific I2C pins) with data rates of up to 1 Mbit/s.
- Support high-speed slave mode with data rates of up to 3.4 Mbit/s (specific I2C pins).
- Independent Master, Slave, and Monitor functions.
- Supports both Multi-master and Multi-master with Slave functions.
- Multiple I²C slave addresses supported in hardware.
- One slave address can be selectively qualified with a bit mask or an address range in order to respond to multiple I²C-bus addresses.
- 10-bit addressing supported with software assist.
- Supports SMBus.
- Separate DMA requests for master, slave, and monitor functions.
- No chip clocks are required in order to receive and compare an address as a slave, so this event can wake-up the device from deep-sleep mode.
- Automatic modes optionally allow less software overhead for some use cases.

7.26.3.4 USART

Features

- Maximum bit rates of 10 Mbit/s in asynchronous mode and 25 Mbit/s in synchronous mode for USART functions.
- 7, 8, or 9 data bits and 1 or 2 stop bits.
- Synchronous mode with master or slave operation. Includes data phase selection and continuous clock option.
- Multiprocessor/multidrop (9-bit) mode with software address compare.
- RS-485 transceiver output enable.

- Autobaud mode for automatic baud rate detection
- Parity generation and checking: odd, even, or none.
- Software selectable oversampling from 5 to 16 clocks in asynchronous mode.
- One transmit and one receive data buffer.
- RTS/CTS for hardware signaling for automatic flow control. Software flow control can be performed using Delta CTS detect, Transmit Disable control, and any GPIO as an RTS output.
- Received data and status can optionally be read from a single register
- Break generation and detection.
- Receive data is 2 of 3 sample "voting". Status flag set when one sample differs.
- Built-in Baud Rate Generator with auto-baud function.
- A fractional rate divider is shared among all USARTs.
- Interrupts available for Receiver Ready, Transmitter Ready, Receiver Idle, change in receiver break detect, Framing error, Parity error, Overrun, Underrun, Delta CTS detect, and receiver sample noise detected.
- Loopback mode for testing of data and flow control.
- In synchronous slave mode, wakes up the part from deep-sleep and deep-sleep2 modes.
- Special operating mode allows operation at up to 9600 baud using the 32.768 kHz RTC oscillator as the UART clock. This mode can be used while the device is in deep-sleep and can wake-up the device when a character is received.
- USART transmit and receive functions work with the system DMA controller.
- The USART function supports separate transmit and receive FIFO with 16 entries each.

7.26.3.5 I²S-bus interface

The I²S bus provides a standard communication interface for streaming data transfer applications such as digital audio or data collection. The I²S bus specification defines a 3-wire serial bus with one data, one clock, and one word select/frame trigger signal, providing single or dual (mono or stereo) audio data transfer in addition to other configurations. Each Flexcomm Interface implements one I²S channel pair.

The I²S interface within one Flexcomm Interface provides one channel pair that can be configured as a master or a slave. The channel pair within one Flexcomm Interface shares one set of I²S signals, and are configured together for either transmit or receive operation, using the same mode, same data configuration, and frame configuration. All such channel pairs can participate in a Time Division Multiplexing (TDM) arrangement. For cases requiring an MCLK input and/or output, this is handled outside of the I²S block in the system level clocking scheme.

Features

- A Flexcomm Interface can implement one or more I²S channel pairs, the first of which could be a master or a slave, and the rest would be slaves. All channel pairs are configured together for either transmit or receive and other shared attributes.
- Flexcomm interfaces 0 to 7 each provide one channel pair of I²S function.
- Configurable data size for all channels within one Flexcomm Interface, from 4 bits to 32 bits. Each channel pair can also be configured independently to act as a single channel (mono as opposed to stereo operation).
- All channel pairs within one Flexcomm Interface share a single bit clock (SCK) and word select/frame trigger (WS), and data line (SDA).
- Data for all I²S traffic within one Flexcomm Interface uses the Flexcomm FIFO. The FIFO depth is 8 entries.
- Left justified and right justified data modes.
- DMA support using FIFO level triggering.
- TDM with a several stereo slots and/or mono slots is supported. Each channel pair can act as any data slot. Multiple channel pairs can participate as different slots on one TDM data line.
- The bit clock and WS can be selectively inverted.

- Sampling frequencies supported depends on the specific device configuration and applications constraints (For example, system clock frequency and PLL availability) but generally supports standard audio data rates.

7.26.4 High-speed SPI serial I/O controller

7.26.4.1 Features

- Master and slave operation.
- The maximum supported bit rate for SPI master mode (transmit/receive) and slave mode (transmit/receive) is 50 Mbit/s.
- Data frames of 4 to 16 bits supported directly. Larger frames supported by software.
- The SPI function supports separate transmit and receive FIFOs with eight entries each.
- Supports DMA transfers: SPIn transmit and receive functions can operated with the system DMA controller.
- Data can be transmitted to a slave without the need to read incoming data. This can be useful while setting up an SPI memory.
- Up to Four Slave Select input/outputs with selectable polarity and flexible usage.

7.27 SDIO/MMC interface

Secured digital input/output (SD/MMC and SDIO) card interface with DMA support. SDIO with support for up to two cards. Supported card types are MMC, SDIO, and CE-ATA. Supports SD2.0, and SDR25 (52MHz).

7.27.1 Features

- Secure Digital memory protocol commands.
- Secure Digital I/O protocol commands.
- Multimedia Card protocol commands.
- CE-ATA digital protocol commands.
- Two SD or MMC (4.4), CE-ATA (1.1), or eMMC (4.4) device.
- CRC 2.0 generation and error detection.
- SDIO interrupts in 1-bit and 4-bit modes.
- Block size of 1 to 65,535 bytes.
- Internal (bus mastering) DMA.
- Two FIFOs, TX and RX FIFO (FIFO depth = 32 and FIFO data width = 32 bits).

7.28 Standard counter/timers (CT32B0 to 4)

The LPC55S6x includes five general-purpose 32-bit timer/counters.

The timer/counter is designed to count cycles of the system derived clock or an externally-supplied clock. It can optionally generate interrupts, generate timed DMA requests, or perform other actions at specified timer values, based on four match registers. Each timer/counter also includes two capture inputs to trap the timer value when an input signal transitions, optionally generating an interrupt.

7.28.1 Features

- A 32-bit timer/counter with a programmable 32-bit prescaler.
- Counter or timer operation.
- Up to four 32-bit capture channels per timer, that can take a snapshot of the timer value when an input signal transitions. A capture event may also generate an interrupt.
- The timer and prescaler may be configured to be cleared on a designated capture

event. This feature permits easy pulse width measurement by clearing the timer on the leading edge of an input pulse and capturing the timer value on the trailing edge.

- Four 32-bit match registers that allow:
 - Continuous operation with optional interrupt generation on match.
 - Stop timer on match with optional interrupt generation.
 - Reset timer on match with optional interrupt generation.
- Up to four external outputs per timer corresponding to match registers with the following capabilities:
 - Set LOW on match.
 - Set HIGH on match.
 - Toggle on match.
 - Do nothing on match.
- Up to two match registers can be used to generate timed DMA requests.
- Up to 4 match registers can be configured for PWM operation, allowing up to 3 single edged controlled PWM outputs. WM mode using up to three match channels for PWM output.

7.28.2 SCTimer/PWM subsystem

The SCTimer/PWM is a flexible timer module capable of creating complex PWM waveforms and performing other advanced timing and control operations with minimal or no CPU intervention.

The SCTimer/PWM can operate as a single 32-bit counter or as two independent, 16-bit counters in uni-directional or bi-directional mode. It supports a selection of match registers against which the count value can be compared, and capture registers where the current count value can be recorded when some pre-defined condition is detected.

The SCTimer/PWM module supports multiple separate events that can be defined by the user based on some combination of parameters including a match on one of the match registers, and/or a transition on one of the SCTimer/PWM inputs or outputs, the direction of count, and other factors.

Every action that the SCTimer/PWM block can perform occurs in direct response to one of these user-defined events without any software overhead. Any event can be enabled to:

- Start, stop, or halt the counter.
- Limit the counter which means to clear the counter in unidirectional mode or change its direction in bi-directional mode.
- Set, clear, or toggle any SCTimer/PWM output.
- Force a capture of the count value into any capture registers.
- Generate an interrupt of DMA request.

7.28.2.1 Features

- The SCTimer/PWM Supports:
 - Eight inputs.
 - Ten outputs.
 - Sixteen match/capture registers.
 - Sixteen events.
 - Thirty two states.
- Counter/timer features:
 - Each SCTimer/PWM is configurable as two 16-bit counters or one 32-bit counter.
 - Counters clocked by system clock or selected input.
 - Configurable number of match and capture registers. Up to sixteen match and capture registers total.
 - Sixteen events.

- Thirty two states.
- Upon match and/or an input or output transition create the following events: interrupt; stop, limit, halt the timer or change counting direction; toggle outputs; change the state.
- Counter value can be loaded into capture register triggered by a match or input/output toggle.
- PWM features:
 - Counters can be used in conjunction with match registers to toggle outputs and create time-proportioned PWM signals.
 - Up to ten single-edge or eight dual-edge PWM outputs with independent duty cycle and common PWM cycle length.
- Event creation features:
 - The following conditions define an event: a counter match condition, an input (or output) condition such as an rising or falling edge or level, a combination of match and/or input/output condition.
 - Selected events can limit, halt, start, or stop a counter or change its direction.
 - Events trigger state changes, output toggles, interrupts, and DMA transactions.
 - Match register 0 can be used as an automatic limit.
 - In bi-directional mode, events can be enabled based on the count direction.
 - Match events can be held until another qualifying event occurs.
- State control features:
 - A state is defined by events that can happen in the state while the counter is running.
 - A state changes into another state as a result of an event.
 - Each event can be assigned to one or more states.
 - State variable allows sequencing across multiple counter cycles.

7.28.3 Windowed WatchDog Timer (WWDT)

The purpose of the Watchdog Timer is to reset or interrupt the microcontroller within a programmable time if it enters an erroneous state. When enabled, a watchdog reset is generated if the user program fails to feed (reload) the Watchdog within a predetermined amount of time.

7.28.3.1 Features

- Internally resets chip if not reloaded during the programmable time-out period.
- Optional windowed operation requires reload to occur between a minimum and maximum time period, both programmable.
- Optional warning interrupt can be generated at a programmable time prior to watchdog time-out.
- Programmable 24-bit timer with internal fixed pre-scaler.
- Selectable time period from 1,024 watchdog clocks ($TWDCLK \times 256 \times 4$) to over 67 million watchdog clocks ($TWDCLK \times 224 \times 4$) in increments of four watchdog clocks.
- "Safe" watchdog operation. Once enabled, requires a hardware reset or a Watchdog reset to be disabled.
- Incorrect feed sequence causes immediate watchdog event if enabled.
- The watchdog reload value can optionally be protected such that it can only be changed after the "warning interrupt" time is reached.
- Flag to indicate Watchdog reset.
- The watchdog clock (WDCLK) is generated from always on FRO_1MHz clock which can be divided by WDT clock divider register. The accuracy of this clock is limited to +/- 15% over temperature, voltage, and silicon processing variations.
- The Watchdog timer can be configured to run in Deep-sleep mode.
- Debug mode.

7.28.4 RTC timer

The RTC block to count seconds and generate an alarm interrupt to the processor whenever the counter value equals the value programmed into the associated 32-bit match register.

7.28.4.1 Features

- The RTC oscillator has the following clock outputs: 32.768 kHz clock (named as 32 kHz clock in rest of this chapter) 32 kHz clock, selectable for system clock and CLKOUT pin, 1 Hz clock for RTC timing, and 1024 Hz clock (named as 1 kHz clock in rest of this chapter) for high-resolution RTC timing.
- 32-bit, 1 Hz RTC counter and associated match register for alarm generation.
- 15-bit, 32KHz sub-second counter.
- Separate 16-bit high-resolution/wake-up timer clocked at 1 kHz for 1 ms resolution with a more than one minute maximum time-out period.
- RTC alarm and high-resolution/wake-up timer time-out each generate independent interrupt requests that go to one NVIC channel. Either time-out can wake up the part from any of the low power modes, including deep power-down.
- Eight 32-bit general purpose registers can retain data in deep power-down. These registers are reset only on software reset of the RTC.

7.28.5 Multi-Rate Timer (MRT)

The Multi-Rate Timer (MRT) provides a repetitive interrupt timer with four channels. Each channel can be programmed with an independent time interval, and each channel operates independently from the other channels.

7.28.5.1 Features

- 24-bit interrupt timer.
- Four channels independently counting down from individually set values.
- Repeat interrupt, one-shot interrupt, and one-shot bus stall modes.

7.28.6 OS Timer

42-bit free running timer with individual match/capture and interrupt generation logic used as continuous time-base for the system, available in any reduced power modes. It runs on 32kHz clock source, allowing a count period of more than 4 years.

7.28.6.1 Features

- Central 42-bit, free-running gray-code event/timestamp timer.
Match registers compared to the main counter to generate an interrupt and/or wake-up event.
- Capture registers triggered by CPU command, readable via the AHB/IPS bus.
- APB interface for register access.
- IRQ and wake-up.
- Reads of gray-encoded timers are accomplished with no synchronization latency.

7.28.7 Micro-tick timer (UTICK)

The ultra-low power Micro-tick Timer, running from the Watchdog oscillator, can be used to wake up the device from sleep and deep-sleep modes.

7.28.7.1 Features

- Ultra simple timer.
- Write once to start.
- Interrupt or software polling.
- Four capture registers that can be triggered by external pin transitions.

7.29 Digital peripherals

7.29.1 DMA controller

The DMA controller allows peripheral-to memory, memory-to-peripheral, and memory-to-memory transactions. Each DMA stream provides unidirectional DMA transfers for a single source and destination.

Two identical DMA controllers are provided on the LPC55S6x. The user may elect to dedicate one of these to CPU0 and the other for use by the CPU1 and/or one may be used as a secure DMA the other non-secure.

7.29.1.1 Features

- DMA0: 22 channels, 21 of which are connected to peripheral DMA requests. These come from the Flexcomm (USART, SPI, I2C, and I2S), high-speed SPI interface, ADC, AES, and SHA interfaces. 22 trigger sources are available.
- DMA1: 10 channels, 9 of which are connected to peripheral DMA requests. These come from the Flexcomm Interfaces (0, 1, and 3), high-speed SPI interface, AES, and SHA interfaces. 15 trigger sources are available.
- DMA operations can be triggered by on-chip or off-chip events.
- Priority is user selectable for each channel (up to eight priority levels).
- Continuous priority arbitration.
- Address cache with four entries.
- Efficient use of data bus.
- Supports single transfers up to 1,024 words.
- Address increment options allow packing and/or unpacking data.

7.29.2 Programmable Logic Unit (PLU)

The PLU is comprised of 26 5-input LUT elements. Each LUT element contains a 32-bit truth table (look-up table) register and a 32:1 multiplexer. During operation, the five LUT inputs control the select lines of the multiplexer. This structure allows any desired logical combination of the five LUT inputs.

7.29.2.1 Features

- The Programmable Logic Unit is used to create small combinatorial and/or sequential logic networks including simple state machines.
- Eight primary outputs can be selected using a multiplexer from among all of the LUT outputs and the four flip-flops.
- An external clock to drive the four flip-flops must be applied to the PLU_CLKIN pin if a sequential network is implemented.
- Programmable logic can be used to drive on-chip inputs/triggers through external pin-to-pin connections.
- A tool suite is provided to facilitate programming of the PLU to implement the logic network described in a Verilog RTL design.
- Any of the eight selected PLU outputs can be enabled to contribute to an asynchronous wake-up or an interrupt request from sleep and deep-sleep modes.

7.29.3 CRC engine

The Cyclic Redundancy Check (CRC) generator with programmable polynomial settings supports several CRC standards commonly used. To save system power and bus bandwidth, the CRC engine supports DMA transfers.

7.29.3.1 Features

- Supports three common polynomials CRC-CCITT, CRC-16, and CRC-32.
 - CRC-CCITT : $x^{16} + x^{12} + x^5 + 1$
 - CRC-16 : $x^{16} + x^{15} + x^2 + 1$
 - CRC-32 : $x^{32} + x^{26} + x^{23} + x^{22} + x^{16} + x^{12} + x^{11} + x^{10} + x^8 + x^7 + x^5 + x^4 + x^2 + x + 1$
- Bit order reverse and 1's complement programmable setting for input data and CRC sum.
- Programmable seed number setting.
- Supports CPU PIO or DMA back-to-back transfer.
- Accept any size of data width per write: 8, 16 or 32-bit.
 - 8-bit write : 1-cycle operation.
 - 16-bit write : 2-cycle operation (8-bit x 2-cycle).
 - 32-bit write: 4-cycle operation (8-bit x 4-cycle).

7.30 Analog peripherals

7.30.1 16-bit Analog-to-Digital Converter (ADC)

The ADC supports a resolution of 16-bit and fast conversion rates of up to 1.0 Msamples/s. Sequences of analog-to-digital conversions can be triggered by multiple sources.

7.30.1.1 Features

- 16-bit Linear successive approximation algorithm.
- Differential operation with 16-bit or 13-bit resolution.
- Single-ended operation with 16-bit or 12-bit resolution.
- Support for simultaneous conversions, on two ADC input channels belonging to a differential pair.
- Channel support for up to 10 analog input channels for conversion of external pin and from internal sources.
- Select external pin inputs paired for conversion as differential channel input.
- Measurement of on-chip analog sources such as DAC, temperature sensor or bandgap.
- Configurable analog input sample time.
- Configurable speed options to accommodate operation in low power modes of SoC.
- Trigger detect with up to 16 trigger sources with priority level configuration. Software or hardware trigger option for each.
- Fifteen command buffers allow independent options selection and channel sequence scanning.
- Automatic compare for less-than, greater-than, within range, or out-of-range with "store on true" and "repeat until true" options.
- Two independent result FIFOs each contains 16 entries. Each FIFO has configurable watermark and overflow detection.
- Interrupt, DMA, or polled operation.
- Linearity and gain offset calibration logic.

7.30.2 Comparator

The analog comparator can compare voltage levels on external pins and internal voltages. The comparator has five inputs multiplexed separately to its positive and negative inputs.

7.30.2.1 Features

- Selectable external inputs can be used as either the positive or negative input of the comparator. Voltage ladder source selectable between the supply, multiplexing between internal VBAT_PMU and ACMPVREF.
- 32-stage voltage ladder can be used as either the positive or negative input of the comparator.
- Supports standard and low power modes
- Interrupt capability.

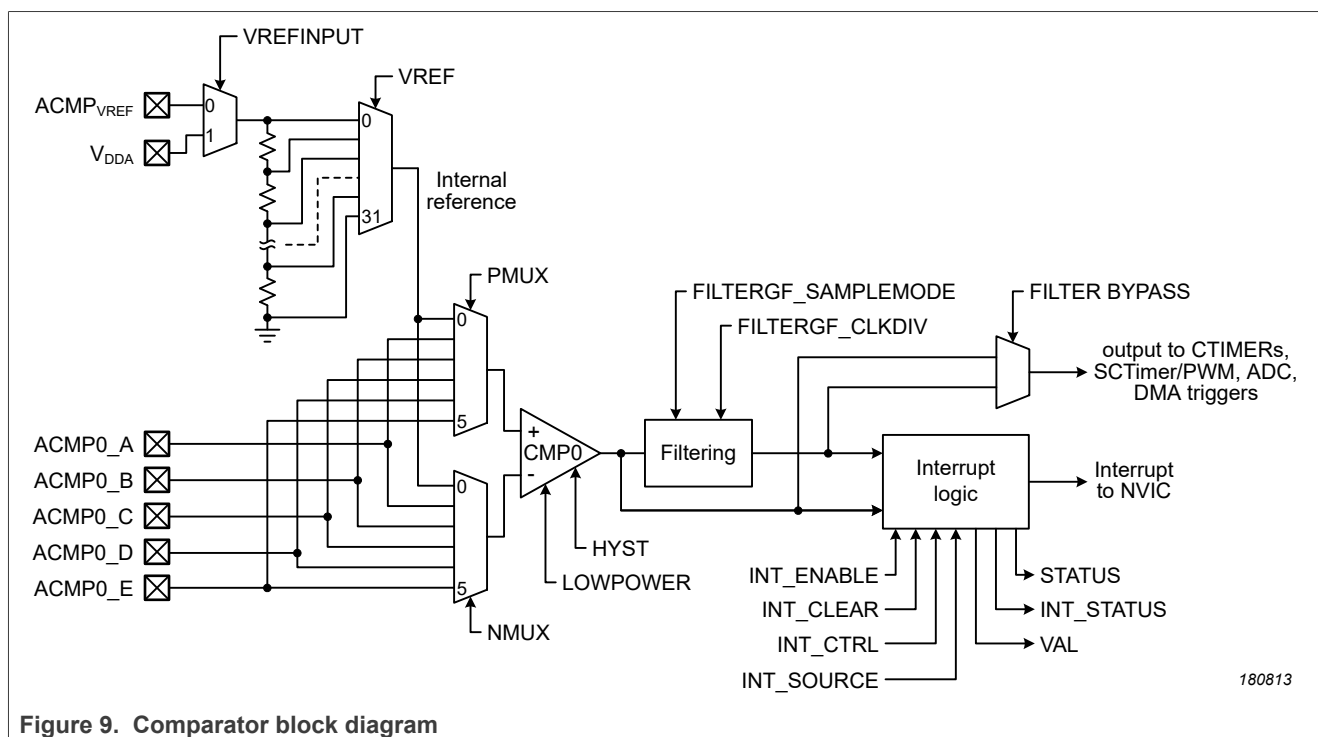

7.30.3 Temperature sensor

The ADC has a dedicated input channel for an on-chip temperate sensor that is mapped on channel 26.

7.31 Security Features

The security system on LPC55S6xLPC55S6x has a set of hardware blocks and ROM code to implement the security features of the device. The hardware consists of an AES engine, a Secure Hash Algorithm (SHA) engine, a Random Number Generator (RNG), a PRINCE engine for real-time flash encryption/decryption, and a key storage block that keys from an SRAM based PUF (Physically Unclonable Function). All components of the system can be accessed by the processor or the DMA engine to encrypt or decrypt data and for hashing. The ROM is responsible for secure boot in addition to providing support for various security functions.

7.31.1 AES engine

The LPC55S6xx devices provide an on-chip hardware AES encryption and decryption engine to protect the image content and to accelerate processing for data encryption or decryption, data integrity, and proof of origin. Data can be encrypted or decrypted by the AES engine using a key from the PUF or a software supplied key. The AES engine supports 128 bit, 192 bit, or 256 bit keys for encryption and decryption operations.

7.31.1.1 Features

- Encryption and decryption of data.
- Secure storage of AES key that cannot be read.
- Supports 128 bit, 192 bit or 256 bit key in Electronic Code Book (ECB) mode, Cipher Block Chaining (CBC) mode, and Counter (CTR) mode.
- Supports 128-bit key in ICB (Indexed Code Book) mode, that offers protection against side-channel attacks.
- Compliant with the FIPS (Federal Information Processing Standard) Publication 197, Advanced Encryption Standard (AES).
- It may use the processor, DMA, or AHB Master for data movement. AHB Master may only be used to load data, DMA may be used to read-out results. DMA based result reading is a "trigger", so the application must set the size correctly.

7.31.2 HASH engine

The LPC55S6x devices provide on-chip Hash support to perform SHA-1 and SHA-2 with 256-bit digest (SHA-256). Hashing is a way to reduce arbitrarily large messages or code images to a relatively small fixed size "unique" number called a digest. The SHA-1 Hash produces a 160 bit digest (five words), and the SHA-256 hash produces a 256 bit digest (eight words).

7.31.2.1 Features

- Performs SHA-1 and SHA-2(256) based hashing.
- Used with HMAC to support a challenge/response or to validate a message.

7.31.3 PUF

The PUF controller on the LPC55S6x provides generation and secure storage for keys without storing the key. The PUF controller provides a unique key per device and exists in that device based on the unique characteristics of PUF SRAM. Instead of storing the key, a Key Code is generated, which in combination with the digital fingerprint is used to reconstruct keys that are routed to the AES engine, for use by software, and by PRINCE engine. PUF keys have a dedicated path to the AES engine and PRINCE engine. There is no other mechanism by which keys can be observed.

7.31.3.1 Features

- Key strength of 256-bits.
- The PUF constructs 256-bit strength device unique PUF root key using the digital fingerprint of a device derived from SRAM and error correction data called Activation Code (AC). The Activation Code (AC) is generated during enrollment process. The Activation Code (AC) should be stored on external non-volatile memory device in the system.
- Generation, storage, and reconstruction of keys.
- Key sizes from 64 bits to 4096 bits.
- PUF controller allows storage of keys, generated externally or on chip, of sizes 64 bits to 4096 bits.

- PUF controller combines keys with digital fingerprint of device to generate key codes. These key codes should be provided to the controller to reconstruct original key. They can be stored on external non-volatile memory device in the system.
- Key output via dedicated hardware interface or through register interface.
- PUF controller allows to assign a 4-bit index value for each key while generating key codes. Keys that are assigned index value zero are output through HW bus, accessible to AES and PRINCE engines only. Keys with non-zero index are available through APB register interface.
- 32-bit APB interface.

7.31.4 Random Number Generator

The True Random Number Generators (TRNG) module is a hardware accelerator module that generate 256-bit entropy. The purpose of the module is to generate high quality, cryptographically secure, random data.

Random number generators are used for data masking, cryptographic modeling and simulation applications that employ keys that must be generated in a random fashion. The chip embeds a hardware IP that, combined with appropriate software and the availability of a stochastic model, can be used to generate random numbers.

7.31.5 PRINCE On-the-fly encryption/decryption

LPC55S6x devices offer support for on-the-fly encryption of data being written to flash and decryption of encrypted on-chip flash data during read using the PRINCE encryption algorithm. Compared to AES, PRINCE is fast as it can decrypt and encrypt in one clock cycle. Also, it does not need extra SRAM to copy data. It operates on a block-size of 64 bits with an 128-bit key. This functionality is useful for asset protection, such as securing application code, securing stored keys and enabling secure flash update.

7.31.6 Universally Unique Identifier (UUID)

Each LPC55S6x device consists of a unique 128-bit IETF RFC4122 compliant non-sequential UUID. It can be read from the protected flash region (register location 0x0009_FC70 onwards).

7.31.7 Device Identifier Composition Engine (DICE)

The LPC55S6x (secure part) supports Device Identifier Composition Engine (DICE) to provide Composite Device Identifier (CDI). The CDI value is available at SYSCON for consumption after boot completion. It is recommended to overwrite these registers once ephemeral key-pairs are generated using this value.

7.32 Debug Mailbox and Authentication

The Debugger Mailbox (DM) AP offers a register based mailbox accessible by both CPUs and the device debug port DP of the MCU. This port is always enabled and external world can send and receive data to/from ROM. This port is used to implement NXP Debug Authentication Protocol. BootROM implements debug mailbox protocol to interact with tools over SWD interface. LPC55S6x offers a debug authentication protocol as a tool to authenticate the debugger and grant it access to the device. The debug authentication scheme on LPC55S6x is a challenge-response scheme and assures that debugger in possession of required debug credentials only can successfully authenticate over debug interface and access restricted parts of the device. This protocol provides a mechanism for a device and its debug interface to authenticate the identity and credentials of the debugger (or user). Access right settings can be pre-configured and gets loaded into register above upon successful debug authentication. Until debug authentication process is successfully completed, secure part of the device is non-accessible to the debugger.

7.33 Emulation and debugging

Debug and trace functions are integrated into the Arm Cortex-M33 (CPU0 and CPU1) Serial wire debug and trace function (Serial Wire Output) are supported. Eight breakpoints and four watch points are supported. In addition, JTAG boundary scan mode is provided.

The Arm SYSREQ reset is supported and causes the processor to reset the peripherals, execute the boot code, restart from address 0x0000 0000, and break at the user entry point.

The SWD pins are multiplexed with other digital I/O pins. On reset, the pins assume the SWD functions by default.

8 Limiting values

Table 11. Limiting values

In accordance with the Absolute Maximum Rating System (IEC 60134).^[1]

| Symbol | Parameter | Conditions | | Min | Max | Unit |
|--------------------|--|---|-------------------|------|-----------------------|------|
| V _{DD} | Main IO supply | | ^[2] | -0.3 | 3.96 | V |
| VBAT_DCDC | Supply of DCDC output stage. DCDC core supply (references and regulation stages) | | ^[2] | -0.3 | 3.96 | V |
| VBAT_PMU | Analog supply | | ^[2] | -0.3 | 3.96 | V |
| VDD_PMU | Analog supply for Core. DCDC output | | ^[2] | -0.3 | 1.26 | V |
| USB0_3V3 | USB0 analog 3.3 V supply. | | ^[2] | -0.3 | 3.96 | V |
| USB1_3V3 | USB1 analog 3.3 V supply. | | ^[2] | -0.3 | 3.96 | V |
| V _{DDA} | Analog supply voltage for ADC | | ^[2] | -0.3 | 3.96 | V |
| V _{refp} | ADC positive reference voltage | | ^[2] | -0.3 | 3.96 | V |
| V _I | input voltage | only valid when the V _{DD} ≥ 1.8 V | | -0.5 | V _{DD} + 0.5 | V |
| V _I | input voltage | on I2C open-drain pins | ^[3] | -0.5 | V _{DD} + 0.5 | V |
| | | USB_DM, USB_DP pins | | -0.3 | USB_3V3 + 0.5 | V |
| V _{IA} | analog input voltage | on digital pins configured for an analog function | ^{[4][5]} | -0.3 | 3.96 | V |
| I _{DD} | total supply current | per supply pin (HLQFP100, VFBGA98, and VFBGA59) | | - | 256 | mA |
| I _{SS} | total ground current | per ground pin (HLQFP100, VFBGA98, and VFBGA59) | | - | 256 | mA |
| I _{latch} | I/O latch-up current | -(0.5V _{DD}) < V _I < (1.5V _{DD}); T _j < 125 °C | | - | 100 | mA |
| T _{stg} | storage temperature | | | -65 | +150 | °C |

Table 11. Limiting values...continued

In accordance with the Absolute Maximum Rating System (IEC 60134).^[1]

| Symbol | Parameter | Conditions | Min | Max | Unit |
|------------------|---------------------------------|-------------------------------|-----|------|------|
| V _{ESD} | electrostatic discharge voltage | human body model; all pins | [6] | 2000 | V |
| V _{ESD} | electrostatic discharge voltage | charge device model; all pins | [6] | 500 | V |

[1] The following applies to the limiting values:

1. This product includes circuitry specifically designed for the protection of its internal devices from the damaging effects of excessive static charge. Nonetheless, it is suggested that conventional precautions be taken to avoid applying greater than the rated maximum.
2. Parameters are valid over operating temperature range unless otherwise specified. All voltages are with respect to V_{SS} unless otherwise noted.
3. The limiting values are stress ratings only and operating the part at these values is not recommended and proper operation is not guaranteed. The conditions for functional operation are specified in [Table 24](#).
- 2] Maximum/minimum voltage above the maximum operating voltage (see [Table 24](#)) and below ground that can be applied for a short time (< 10 ms) to a device without leading to irrecoverable failure. Failure includes the loss of reliability and shorter lifetime of the device.
- 3] V_{DD} present or not present. Compliant with the I²C-bus standard. 5.5 V can be applied to this pin when V_{DD} is powered down.
- 4] An ADC input voltage above 3.6 V can be applied for a short time without leading to immediate, unrecoverable failure. Accumulated exposure to elevated voltages at 4.6 V must be less than 10⁶ s total over the lifetime of the device. Applying an elevated voltage to the ADC inputs for a long time affects the reliability of the device and reduces its lifetime.
- 5] It is recommended to connect an overvoltage protection diode between the analog input pin and the voltage supply pin.
- 6] Human body model: equivalent to discharging a 100 pF capacitor through a 1.5 kΩ series resistor.

9 Thermal characteristics

The average chip junction temperature, T_j (°C), can be calculated using the following equation:–

$$T_j = T_{amb} + (P_D \times R_{th(j-a)}) \quad (1)$$

- T_{amb} = ambient temperature (°C),
- R_{th(j-a)} = the package junction-to-ambient thermal resistance (°C/W)
- P_D = sum of internal and I/O power dissipation

The internal power dissipation is the product of I_{DD} and V_{DD}. The I/O power dissipation of the I/O pins is often small and many times can be negligible. However it can be significant in some applications.

Table 12. Thermal resistance

| Symbol | Parameter | Conditions | Max/Min | Unit |
|-------------------------|--|-------------------------------|---------|------|
| HLQFP100 Package | | | | |
| R _{th(j-a)} | thermal resistance from junction to ambient ^[1] | JESD51-9, 2s2p ^[2] | 27 | °C/W |
| R _{th(j-c)} | thermal resistance from junction to case ^[3] | JESD51-9 ^[2] | 2.0 | °C/W |
| VFBGA98 Package | | | | |
| R _{th(j-a)} | thermal resistance from junction to ambient ^[1] | JESD51-9, 2s2p ^[2] | 56 | °C/W |
| R _{th(j-c)} | Junction-to-Top of Package Thermal Characterization Parameter ^[3] | JESD51-9 ^[2] | 0.7 | °C/W |
| HTQFP 64 Package | | | | |
| R _{th(j-a)} | thermal resistance from junction to ambient ^[1] | JESD51-9, 2s2p ^[2] | 28 | °C/W |
| R _{th(j-c)} | thermal resistance from junction to case ^[3] | JESD51-9 ^[2] | 0.3 | °C/W |

Table 12. Thermal resistance...continued

| Symbol | Parameter | Conditions | Max/Min | Unit |
|-------------------------|---|-------------------------------|---------|------|
| VFBGA 59 Package | | | | |
| $R_{th(j-a)}$ | Thermal resistance from junction to ambient | JESD51-9, 2s2p ^[2] | 47.9 | °C/W |
| Ψ_{JT} | Junction-to-Top of Package Thermal Characterization Parameter | JESD51-9, 2s2p | 0.2 | °C/W |

[1] Determined in accordance to JEDEC JESD51-2A natural convection environment. Thermal resistance data in this report is solely for a thermal performance comparison of one package to another in a standardized specified environment. It is not meant to predict the performance of a package in an application-specific environment

[2] Thermal test board meets JEDEC specification for this package (JESD51-9).

[3] Junction-to-Case thermal resistance determined using an isothermal cold plate. Case is defined as the bottom of the packages (exposed pad)

Table 13. Maximum Junction Temperature

| Symbol | Parameter | Conditions | Max | Unit |
|------------------------------|--|---|-------|------|
| T_{jmax} (Device) | maximum junction temperature for Device | Device operating per datasheet spec | + 107 | °C |
| T_{jmax} (Silicon Process) | maximum junction temperature for Silicon Process | Device operating, datasheet specifications not guaranteed | + 125 | °C |

10 Static characteristics

10.1 General operating conditions

Table 14. General operating conditions

$T_{amb} = -40\text{ °C to }+105\text{ °C}$, unless otherwise specified.

| Symbol | Parameter | Conditions | Min | Typ ^[1] | Max | Unit |
|------------------------------|--|---|-------|--------------------|------------------------|------|
| f_{clk} | clock frequency | internal CPU/system clock | - | - | 150 ^{[2] [3]} | MHz |
| f_{clk} | clock frequency | For USB high-speed device and host operations | 90 | - | 150 ^{[2] [3]} | MHz |
| f_{clk} | clock frequency | For USB full-speed device and host operations | 12 | - | 150 ^{[2] [3]} | MHz |
| V_{DD} | Main IO supply | | 1.8 | - | 3.6 | V |
| V_{BAT_DCDC} | Supply of DCDC output stage. DCDC core supply (references and regulation stages) | | 1.8 | - | 3.6 | V |
| V_{BAT_PMU} | Analog supply | | 1.8 | - | 3.6 | V |
| V_{DD_PMU} ^[4] | Analog supply for Core. DCDC output | | 1.0 | - | 1.2 | V |
| $USB0_3V3$ | USB0 analog 3.3 V supply. | | 3.0 | - | 3.6 | V |
| $USB1_3V3$ | USB1 analog 3.3 V supply. | | 3.0 | - | 3.6 | V |
| V_{DDA} | Analog supply voltage for ADC | | 1.8 | - | 3.6 | V |
| V_{refp} | ADC positive reference voltage | | 0.985 | - | V_{DDA} | V |

[1] Typical ratings are not guaranteed. The values listed are for room temperature (25 °C), nominal supply voltages.

- [2] Device revision 1B operates at a maximum CPU frequency of up to 150 MHz. Device revision 0A operates at a maximum CPU frequency of up to 100 MHz.
- [3] Flash operations (erase, blank check, program) and reading single word can only be performed for CPU frequencies of up to 100 MHz. Cannot be performed for frequencies above 100 MHz.
- [4] For device revision 1B, power library in SDK sets the DCDC output based on the frequency selected. For frequencies 100 MHz or below, DCDC output is set between 1.0 V to 1.075 V, for frequencies between 101 MHz to 130 MHz, DCDC output is set between 1.025 V to 1.150 V and for frequencies above 130 MHz, DCDC output is set between 1.050 V to 1.2 V. For device revision 0A, the default typical DCDC output is 1.1 V and for device revision 1B, the typical default DCDC output is 1.0 V.

10.2 CoreMark data

Table 15. CoreMark score ^[1]

$T_{amb} = 25^{\circ}\text{C}$, $V_{BAT_PMU} = V_{BAT_DCDC} = V_{DD} = 3.0\text{ V}$

| Parameter | Conditions | | Typ ^[2] | Unit |
|--|---|-----------|--------------------|----------------------|
| ARM Cortex-M33 (CPU0) in active mode; ARM Cortex-M33 (CPU1) in sleep mode | | | | |
| CoreMark score | CoreMark code executed from SRAMX; CCLK = 12 MHz | [3][4] | 4.0 | (Iterations/s) / MHz |
| | CCLK = 48 MHz | [3][4] | 4.0 | (Iterations/s) / MHz |
| | CCLK = 60 MHz | [3][4] | 4.0 | (Iterations/s) / MHz |
| | CCLK = 96 MHz | [3][4] | 4.0 | (Iterations/s) / MHz |
| | CCLK = 100 MHz | [4][5] | 4.0 | (Iterations/s) / MHz |
| | CCLK = 150 MHz | [4][5] | 4.0 | (Iterations/s) / MHz |
| CoreMark score | CoreMark code executed from flash; CCLK = 12 MHz; 2 system clock flash access time. | [3][4][6] | 3.6 | (Iterations/s) / MHz |
| | CCLK = 48 MHz, 5 system clock flash access time. | [3][4][6] | 3.0 | (Iterations/s) / MHz |
| | CCLK = 60 MHz, 6 system clock flash access time. | [3][4][6] | 2.5 | (Iterations/s) / MHz |
| | CCLK = 96 MHz, 8 system clock flash access time. | [3][4][6] | 2.3 | (Iterations/s) / MHz |
| | CCLK = 100 MHz, 8 system clock flash access time. | [4][6][5] | 2.3 | (Iterations/s) / MHz |
| | CCLK = 150 MHz, 12 system clock flash access time. | [4][6][5] | 2.0 | (Iterations/s) / MHz |

- [1] For device revision 1B, power library in SDK sets the DCDC output based on the frequency selected. For frequencies 100 MHz or below, DCDC output is set between 1.0 V to 1.075 V, for frequencies between 101 MHz to 130 MHz, DCDC output is set between 1.025 V to 1.150 V and for frequencies above 130 MHz, DCDC output is set between 1.050 V to 1.2 V. For device revision 0A, the default typical DCDC output is 1.1 V and for device revision 1B, the typical default DCDC output is 1.0 V.
- [2] Characterized through bench measurements using typical samples.
- [3] Clock source FRO. PLL disabled
- [4] Compiler settings: Keil v.5.28, optimization level 3, optimized for time on.
- [5] PLL enabled
- [6] See the FLASHCFG register in the LPC55S6x User Manual for system clock flash access time settings. Power Library in SDK sets the flash wait states based on the frequency selected.

10.3 Power consumption

Table 16. Static characteristics: Power consumption in active mode ^[1]

$T_{amb} = -40\text{ °C to }+105\text{ °C}$, unless otherwise specified. $V_{BAT_PMU} = V_{BAT_DCDC} = V_{DD} = 3.0\text{ V}$

| Symbol | Parameter | Conditions | Min | Typ ^[2] | Max | Unit | |
|--|----------------|--|-----------|--------------------|------|------|----|
| ARM Cortex-M33 (CPU0) in active mode; ARM Cortex-M33 (CPU1) in sleep mode | | | | | | | |
| I_{DD} | supply current | CoreMark code executed from SRAMX; flash powered down CCLK = 12 MHz | [3][4] | - | 0.9 | - | mA |
| | | CCLK = 48 MHz | [3][4] | - | 2.1 | - | mA |
| | | CCLK = 60 MHz | [3][4] | - | 2.3 | - | mA |
| | | CCLK = 96 MHz | [3][4] | - | 3.4 | - | mA |
| | | CCLK = 100 MHz | [4][5] | - | 3.5 | - | mA |
| | | CCLK = 150 MHz | [4][5] | - | 6.2 | - | mA |
| I_{DD} | supply current | CoreMark code executed from flash; CCLK = 12 MHz; 2 system clock flash access time. | [3][4][6] | - | 0.95 | - | mA |
| | | CCLK = 48 MHz, 5 system clock flash access time. | [3][4][6] | - | 2.4 | - | mA |
| | | CCLK = 60 MHz, 6 system clock flash access time. | [3][4][6] | - | 2.6 | - | mA |
| | | CCLK = 96 MHz, 8 system clock flash access time. | [3][4][6] | - | 3.4 | - | mA |
| | | CCLK = 100 MHz, 8 system clock flash access time. | [4][5][6] | - | 3.5 | - | mA |
| | | CCLK = 150 MHz, 12 system clock flash access time. | [4][5][6] | - | 5.9 | - | mA |

[1] For device revision 1B, power library in SDK sets the DCDC output based on the frequency selected. For frequencies 100 MHz or below, DCDC output is set between 1.0 V to 1.075 V, for frequencies between 101 MHz to 130 MHz, DCDC output is set between 1.025 V to 1.150 V and for frequencies above 130 MHz, DCDC output is set between 1.050 V to 1.2 V. For device revision 0A, the default typical DCDC output is 1.1 V and for device revision 1B, the typical default DCDC output is 1.0 V.

[2] Typical ratings are not guaranteed. Typical values listed are at room temperature (25 °C). Characterized through bench measurements using typical samples.

[3] Clock source FRO. PLL disabled

[4] Compiler settings: IAR v.8.20.2., optimization level 0, optimized for time off.

[5] PLL enabled.

[6] See the FLASHCFG register in the LPC55S6x User Manual for system clock flash access time settings. Power Library in SDK sets the flash wait states based on the frequency selected.

Table 17. Static characteristics: Power consumption in active mode ^[1]

$T_{amb} = -40\text{ °C to }+105\text{ °C}$, unless otherwise specified.

| Symbol | Parameter | Conditions | Min | Typ ^[2] | Typ ^[3] | Max | Unit | |
|--|----------------|---|---------|--------------------|--------------------|-----|------|----|
| ARM Cortex-M33 (CPU0) in active mode; ARM Cortex-M33 (CPU1) in sleep mode | | | | | | | | |
| I_{DD} | supply current | CoreMark code executed from SRAMX; flash powered down | | | | | | |
| | | CCLK = 48 MHz, $T_{amb} = 25\text{ °C}$ | [4] [5] | - | 2.1 | 4 | - | mA |
| | | CCLK = 48 MHz, $T_{amb} = 55\text{ °C}$ | [4] [5] | - | 2.2 | 4.2 | - | mA |

Table 17. Static characteristics: Power consumption in active mode ^[1]...continued $T_{amb} = -40\text{ °C to }+105\text{ °C}$, unless otherwise specified.

| Symbol | Parameter | Conditions | | Min | Typ ^[2] | Typ ^[3] | Max | Unit |
|----------|----------------|--|-------------|-----|--------------------|--------------------|-----|------|
| | | CCLK = 48 MHz, $T_{amb} = 85\text{ °C}$ | [4] [5] | - | 2.6 | 4.7 | - | mA |
| | | CCLK = 48 MHz, $T_{amb} = 105\text{ °C}$ | [4] [5] | - | 3.1 | 5.2 | - | mA |
| | | CCLK = 96 MHz, $T_{amb} = 25\text{ °C}$ | [4] [5] | - | 3.4 | 6.5 | - | mA |
| | | CCLK = 96 MHz, $T_{amb} = 55\text{ °C}$ | [4] [5] | - | 3.5 | 6.6 | - | mA |
| | | CCLK = 96 MHz, $T_{amb} = 85\text{ °C}$ | [4] [5] | - | 3.9 | 6.9 | - | mA |
| | | CCLK = 96 MHz, $T_{amb} = 105\text{ °C}$ | [4] [5] | - | 4.4 | 7.5 | - | mA |
| I_{DD} | supply current | CoreMark code executed from flash | | | | | | |
| | | CCLK = 48 MHz; 5 system clock flash access time, $T_{amb} = 25\text{ °C}$ | [4] [5] [6] | - | 2.4 | 4.3 | - | mA |
| | | CCLK = 48 MHz; 5 system clock flash access time, $T_{amb} = 55\text{ °C}$ | [4] [5] [6] | - | 2.5 | 4.5 | - | mA |
| | | CCLK = 48 MHz; 5 system clock flash access time, $T_{amb} = 85\text{ °C}$ | [4] [5] [6] | - | 2.9 | 5 | - | mA |
| | | CCLK = 48 MHz; 5 system clock flash access time, $T_{amb} = 105\text{ °C}$ | [4] [5] [6] | - | 3.3 | 5.5 | - | mA |
| | | CCLK = 96 MHz; 8 system clock flash access time, $T_{amb} = 25\text{ °C}$ | [4] [5] [6] | - | 3.4 | 6.5 | - | mA |
| | | CCLK = 96 MHz; 8 system clock flash access time, $T_{amb} = 55\text{ °C}$ | [4] [5] [6] | - | 3.5 | 6.6 | - | mA |
| | | CCLK = 96 MHz; 8 system clock flash access time, $T_{amb} = 85\text{ °C}$ | [4] [5] [6] | - | 4.1 | 7 | - | mA |
| | | CCLK = 96 MHz; 8 system clock flash access time, $T_{amb} = 105\text{ °C}$ | [4] [5] [6] | - | 4.8 | 7.6 | - | mA |

[1] For device revision 1B, power library in SDK sets the DCDC output based on the frequency selected. For frequencies 100 MHz or below, DCDC output is set between 1.0 V to 1.075 V. Frequencies between 101 MHz to 130 MHz, DCDC output is set between 1.025 V to 1.150 V, and for frequencies above 130 MHz, DCDC output is set between 1.050 V to 1.2 V. For device revision 0A, the default typical DCDC output is 1.1 V and for device revision 1B, the typical default DCDC output is 1.0 V.

[2] Typical ratings are not guaranteed. Typical values listed are at room temperature (25 °C). Characterized through bench measurements using typical samples. VBAT_PMU = VBAT_DCDC = VDD = 3.0 V.

[3] Typical ratings are not guaranteed. Typical values listed are at room temperature (25 °C). Characterized through bench measurements using typical samples. VBAT_PMU = VBAT_DCDC = VDD = 1.8 V

[4] Clock source FRO. PLL disabled

[5] Compiler settings: IAR v.8.20.2., optimization level 0, optimized for time off.

[6] See the FLASHCFG register in the LPC55S6x User Manual for system clock flash access time settings. Power Library in SDK sets the flash wait states based on the frequency selected.

Table 18. Static characteristics: Power consumption in active mode ^[1] $T_{amb} = -40\text{ °C to }+105\text{ °C}$, unless otherwise specified. $V_{BAT_PMU} = V_{BAT_DCDC} = V_{DD} = 3.0\text{ V}$

| Symbol | Parameter | Conditions | Min | Typ ^[2] | Max | Unit | |
|--|----------------|---|----------------------|--------------------|-----|------|----|
| ARM Cortex-M33 (CPU0) in active mode; ARM Cortex-M33 (CPU1) in sleep mode | | | | | | | |
| I_{DD} | supply current | CoreMark code executed from SRAMX; flash powered down | | | | | |
| | | CCLK = 1 MHz, $T_{amb} = 25\text{ °C}$ | ^{[3][4]} | - | 0.8 | - | mA |
| | | CCLK = 16 MHz, $T_{amb} = 25\text{ °C}$ | ^{[4][5]} | - | 1.1 | - | mA |
| I_{DD} | supply current | CoreMark code executed from flash | | | | | |
| | | CCLK = 1 MHz, 1 system clock flash access time, $T_{amb} = 25\text{ °C}$ | ^{[3][4][6]} | - | 0.9 | - | mA |
| | | CCLK = 12 MHz, 2 system clock flash access time, $T_{amb} = 25\text{ °C}$ | ^{[4][5][6]} | - | 1.2 | - | mA |

- [1] For device revision 1B, power library in SDK sets the DCDC output based on the frequency selected. For frequencies 100 MHz or below, DCDC output is set between 1.0 V to 1.075 V. Frequencies between 101 MHz to 130 MHz, DCDC output is set between 1.025 V to 1.150 V, and for frequencies above 130 MHz, DCDC output is set between 1.050 V to 1.2 V. For device revision 0A, the default typical DCDC output is 1.1 V and for device revision 1B, the typical default DCDC output is 1.0 V.
- [2] Typical ratings are not guaranteed. Typical values listed are at room temperature (25 °C). Characterized through bench measurements using typical samples.
- [3] Clock source FRO. System Oscillator disabled. PLL disabled
- [4] Compiler settings: IAR v.8.20.2., optimization level 0, optimized for time off.
- [5] System Oscillator enabled. FRO disabled. PLL disabled.
- [6] See the FLASHCFG register in the LPC55S6x/LPC55S2x User Manual for system clock flash access time settings. Power Library in SDK sets the flash wait states based on the frequency selected.

Table 19. Static characteristics: Power consumption in sleep mode $T_{amb} = -40\text{ °C to }+105\text{ °C}$, unless otherwise specified. $V_{BAT_PMU} = V_{BAT_DCDC} = V_{DD} = 3.0\text{ V}$

| Symbol | Parameter | Conditions | Min | Typ ^[1] | Max | Unit | |
|--|----------------|-----------------------------|-------------------|--------------------|-----|------|----|
| ARM Cortex-M33 (CPU0) in sleep mode; ARM Cortex-M33 (CPU1) OFF (in reset, clock disabled) | | | | | | | |
| I_{DD} | supply current | CCLK = 12 MHz, PLL disabled | ^{[1][2]} | - | 0.7 | - | mA |
| | | CCLK = 96 MHz, PLL disabled | ^[2] | - | 2.7 | - | mA |

- [1] Typical ratings are not guaranteed. Typical values listed are at room temperature (25 °C). Characterized through bench measurements using typical samples.
- [2] Clock source FRO. PLL disabled

Table 20. Static characteristics: Power consumption in deep-sleep, power-down, and deep power-down modes $T_{amb} = -40\text{ °C to }+105\text{ °C}$; unless otherwise specified. I_{DD} is total current from V_{BAT_DCDC} , V_{BAT_PMU} , V_{DDA} , and V_{DD} supply domains. $V_{SUPPLY} = V_{BAT_DCDC} + V_{BAT_PMU} + V_{DDA} + V_{DD}$

| Symbol | Parameter | Conditions | Min | Typ ^{[1][2]} | Max ^[3] | Unit | |
|----------|----------------|--|----------------|-----------------------|--------------------|------|----|
| I_{DD} | supply current | Deep-sleep mode; all SRAM on $T_{amb} = 25\text{ °C}$, $V_{SUPPLY} = 3.0\text{ v}$ | ^[2] | - | 110 | 135 | μA |
| | | $T_{amb} = 25\text{ °C}$, $V_{SUPPLY} = 1.8\text{ v}$ | ^[2] | - | 148 | 191 | μA |
| | | $T_{amb} = 105\text{ °C}$, $V_{SUPPLY} = 1.8\text{ v}$ | ^[2] | - | - | 1850 | μA |
| | | Power-down mode. | ^[2] | | | | |

Table 20. Static characteristics: Power consumption in deep-sleep, power-down, and deep power-down modes...continued

$T_{amb} = -40\text{ °C to }+105\text{ °C}$; unless otherwise specified. I_{DD} is total current from V_{BAT_DCDC} , V_{BAT_PMU} , V_{DDA} , and V_{DD} supply domains. $V_{SUPPLY} = V_{BAT_DCDC} + V_{BAT_PMU} + V_{DDA} + V_{DD}$

| Symbol | Parameter | Conditions | Min | Typ ^{[1][2]} | Max ^[3] | Unit |
|--------|-----------|--|-----|-----------------------|--------------------|------|
| | | SRAM_X2 (4 KB) powered $T_{amb} = 25\text{ °C}$, $V_{SUPPLY} = 3.0\text{ V}$ | - | 3.9 | 4.5 | μA |
| | | SRAM_X2 (4 KB) powered $T_{amb} = 105\text{ °C}$, $V_{SUPPLY} = 3.0\text{ V}$ | - | - | 85 | μA |
| | | SRAM_X2 and SRAM_X3 (8 KB) powered $T_{amb} = 25\text{ °C}$, $V_{SUPPLY} = 3.0\text{ V}$ | - | 4.0 | - | μA |
| | | 320 KB full retention $T_{amb} = 25\text{ °C}$, $V_{SUPPLY} = 3.0\text{ V}$ | - | 14 | 18 | μA |
| | | 320 KB full retention $T_{amb} = 105\text{ °C}$, $V_{SUPPLY} = 3.0\text{ V}$ | - | - | 480 | μA |
| | | SRAM_X2 (4 KB) powered $T_{amb} = 25\text{ °C}$, $V_{SUPPLY} = 3.0\text{ V}$ USART3 enabled as wake-up source | - | 4.2 | - | μA |
| | | SRAM_X2 (4 KB) powered $T_{amb} = 25\text{ °C}$, $V_{SUPPLY} = 3.0\text{ V}$ OSTIMER enabled as wake-up source | - | 4.1 | - | μA |
| | | Deep power-down mode; RTC oscillator input grounded (RTC oscillator disabled, 4 KB SRAM powered) $T_{amb} = 25\text{ °C}$, $V_{SUPPLY} = 3.0\text{ V}$ | - | 590 | 750 | nA |
| | | Deep power-down mode; RTC oscillator input grounded (RTC oscillator disabled, 4 KB SRAM powered) $T_{amb} = 105\text{ °C}$, $V_{SUPPLY} = 3.0\text{ V}$ | - | - | 15 | μA |
| | | RTC oscillator running with external crystal (4 KB SRAM powered) | - | 790 | - | nA |

[1] Typical ratings are not guaranteed. Typical values listed are at room temperature (25 °C).

[2] Characterized through bench measurements using typical samples.

[3] The maximum values represent characterized results equivalent to the mean plus three times the standard deviation (mean + 3 sigma).

Table 21. Static characteristics: ADC Power consumption

$T_{amb} = -40\text{ °C to }+105\text{ °C}$, unless otherwise specified. $0.985\text{ V} \leq V_{REFP} \leq V_{DDA}\text{ V}$; $1.8\text{ V} \leq V_{DDA} \leq 3.6\text{ V}$.

| Symbol | Parameter | Conditions | Min | Typ ^[1] | Max | Unit |
|-----------|-----------------------|--|-----|--------------------|-----|------|
| I_{DDA} | analog supply current | ADC in low power mode (PWRSEL = 0) Idle mode (analog blocks pre-enabled, inc ADC Bias) | - | 0.2 | - | mA |
| | | ADC in low power mode (PWRSEL = 0) Sampling/ SE Conversion mode (analog blocks ON) $f_{adc} = 24\text{ MHz}$ | - | 0.7 | - | mA |

Table 21. Static characteristics: ADC Power consumption...continued

$T_{amb} = -40\text{ °C to }+105\text{ °C}$, unless otherwise specified. $0.985\text{ V} \leq V_{REFP} \leq V_{DDA}\text{ V}$; $1.8\text{ V} \leq V_{DDA} \leq 3.6\text{ V}$.

| Symbol | Parameter | Conditions | Min | Typ ^[1] | Max | Unit |
|-----------------|-----------------------|--|-----|--------------------|-----|------|
| | | Temperature sensor (inc ADC Bias) | - | 60 | - | μA |
| I_{DDA} | Analog supply current | Deep Sleep Mode, ADC OFF | - | 10 | - | nA |
| | | Power Mode, ADC OFF | - | 6 | - | nA |
| | | Deep Power Down Mode, ADC OFF | - | 5 | - | nA |
| $I_{DD(VREFP)}$ | VREFP supply current | ADC Idle mode(analog blocks pre_enabled) | - | 5 | - | nA |

[1] Typical ratings are not guaranteed. The values listed are at room temperature (25 °C), nominal supply voltage.

Table 22. Static characteristics: USB Power consumption

$T_{amb} = -40\text{ °C to }+105\text{ °C}$, unless otherwise specified.

| Symbol | Parameter | Conditions | Min | Typ ^[1] | Max | Unit |
|---------------------|------------------------------|--------------------------------------|-----|--------------------|-----|------|
| $I_{DD(VBUS)}$ | VBUS supply current for USB1 | Power-down mode/Deep-power-down mode | - | 6 | - | μA |
| $I_{DD(USB1_3V3)}$ | USB1 analog 3.3 V supply | Active mode | - | 1.2 | - | mA |

[1] Typical ratings are not guaranteed. The values listed are at room temperature (25 °C), nominal supply voltage.

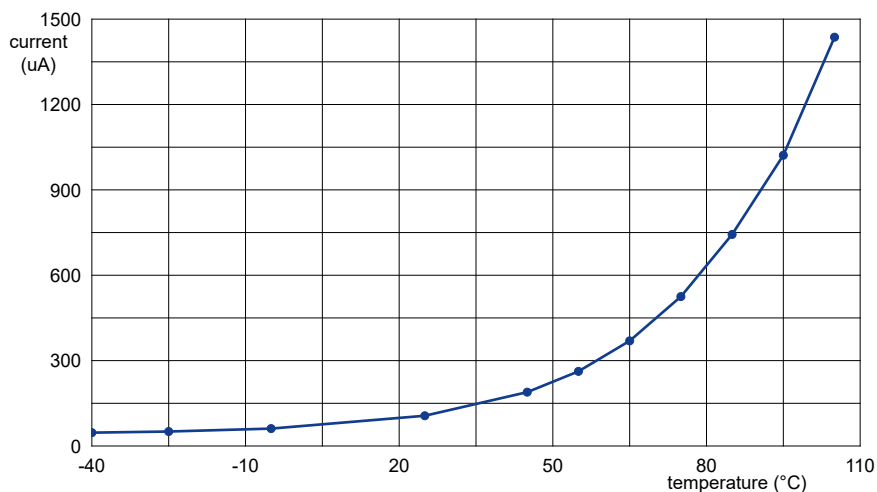

Conditions: all oscillators and analog blocks disabled. All SRAM blocks enabled.

Figure 10. Deep-sleep mode: Typical supply current I_{DD} versus temperature for different supply voltages $VBAT_DCDC$

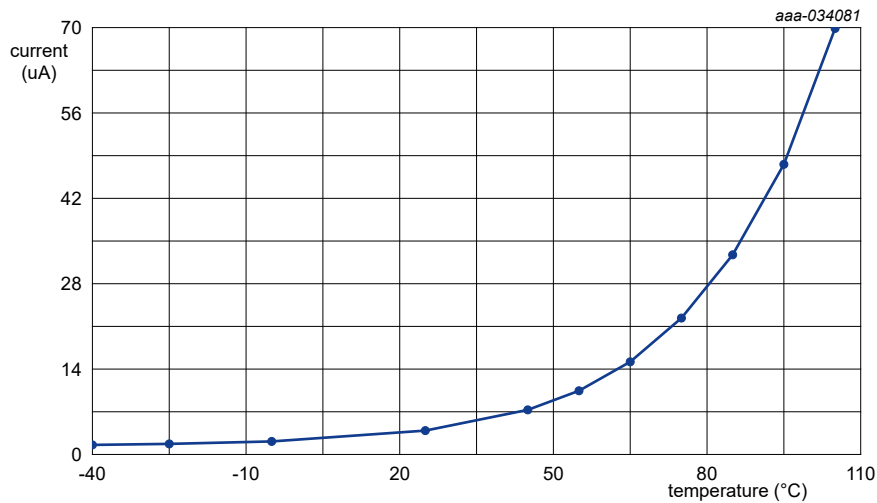

Conditions: all oscillators and analog blocks disabled; all SRAM disabled except 4KB SRAM powered. Flash powered down.

Figure 11. Power-down mode: Typical supply current I_{DD} versus temperature for different supply voltages VBAT_DCDC

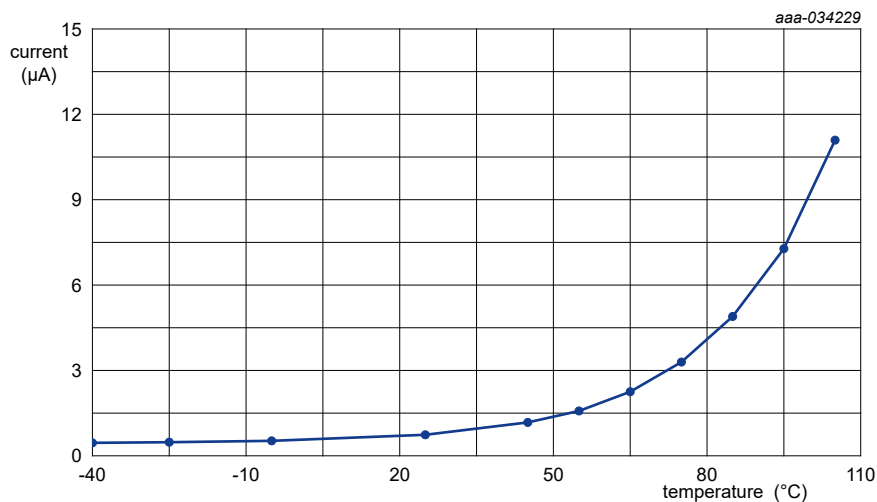

RTC input grounded. 4KB SRAM powered.

Figure 12. Deep power-down mode: Typical supply current I_{DD} versus temperature for different supply voltages VBAT_DCDC

10.3.1 Peripheral Power Consumption

Table 23 shows the typical peripheral power consumption measured on a typical sample at $T_{amb} = 25\text{ °C}$ and $V_{BAT_PMU} = V_{BAT_DCDC} = V_{DD} = 3.3\text{ V}$. The supply current per peripheral is measured as the difference in supply current between the peripheral block enabled and the peripheral block disabled using AHB clock control and PDRUNCFG registers. All other blocks are disabled and no code accessing the peripheral is executed. The supply currents are shown for system clock frequencies of 12 MHz, and 96 MHz.

Table 23. Typical peripheral power consumption
 $V_{BAT_PMU} = V_{BAT_DCDC} = V_{DD} = 3.3\text{ V}$; $T = 25\text{ °C}$

| Peripheral | | I _{DD} (uA) | |
|----------------------|-----|---------------------------|---------------------------|
| FRO (12 MHz) | | 41 | - |
| FRO (1 MHz) | | 3.5 | - |
| FRO (32 KHz) | | 0.3 | - |
| System OSC | | 35 | - |
| 32.768 KHz OSC | | 3.7 | - |
| Flash | | 79 | - |
| BODVBAT | | 0.3 | - |
| SRAM 0 (64 KB) | [1] | 9.5 | - |
| SRAM 1 (64 KB) | [1] | 11.5 | - |
| SRAM 2 (64 KB) | [1] | 11.5 | - |
| SRAM 3 (64 KB) | [1] | 16 | - |
| SRAM 4 (16 KB) | [1] | 16 | - |
| Comparator | | 59 | - |
| Peripheral | | I _{DD} in uA/MHz | I _{DD} in uA/MHz |
| | | CPU: 12 MHz | CPU: 96MHz |
| FS USB0 Device | | 0.8 | 0.8 |
| HS USB1 Device | | 1.0 | 1.3 |
| RNG | | 17 | 2.8 |
| INPUTMUX | [2] | 0.4 | 0.5 |
| IOCON | [2] | 0.6 | 0.6 |
| GPIO0 | [2] | 0.3 | 0.4 |
| GPIO1 | [2] | 0.3 | 0.4 |
| PINT | | 0.5 | 0.5 |
| GINT | | 0.3 | 0.3 |
| DMA0 | | 1.7 | 1.7 |
| DMA1 | | 1.2 | 1.2 |
| CRC | | 0.4 | 0.4 |
| WWDT | | 0.2 | 0.2 |
| RTC | | 0.2 | 0.2 |
| MAILBOX | | 0.2 | 0.2 |
| MRT | | 0.3 | 0.3 |
| SCTimer/PWM | | 1.3 | 1.4 |
| UTICK | | 0.2 | 0.2 |
| OS Timer | | 0.2 | 0.2 |
| Flexcomm Interface 0 | | 0.8 | 0.8 |

Table 23. Typical peripheral power consumption...continued

VBAT_PMU = VBAT_DCDC = V_{DD} = 3.3 V; T = 25 °C

| Peripheral | I _{DD} (uA) | |
|----------------------|----------------------|-----|
| Flexcomm Interface 1 | 0.8 | 0.8 |
| Flexcomm Interface 2 | 0.8 | 0.8 |
| Flexcomm Interface 3 | 0.8 | 0.8 |
| Flexcomm Interface 4 | 0.8 | 0.8 |
| Flexcomm Interface 5 | 0.8 | 0.8 |
| Flexcomm Interface 6 | 0.8 | 0.8 |
| Flexcomm Interface 7 | 0.8 | 0.8 |
| Timer0 | 0.3 | 0.3 |
| Timer1 | 0.3 | 0.3 |
| Timer2 | 0.3 | 0.3 |
| Timer3 | 0.3 | 0.3 |
| Timer4 | 0.3 | 0.3 |
| SDIO | 2.3 | 2.3 |
| USB0 HOST | 1.2 | 1.2 |
| USB1 HOST | 0.8 | 0.8 |
| Power Quad | 0.8 | 0.8 |
| PLU | 0.8 | 0.8 |
| HS SPI | 0.4 | 0.4 |
| CASPER | 0.6 | 0.6 |
| PUF | 2.3 | 2.3 |
| AES_SHA | 0.5 | 0.5 |

[1] Measured in power-down mode

[2] Turn off the peripheral when the configuration is done.

10.4 Pin characteristics

Table 24. Static characteristics: pin characteristics

T_{amb} = -40 °C to +105 °C, unless otherwise specified. 1.8 V ≤ V_{DD} ≤ 3.6 V unless otherwise specified. Values tested in production unless otherwise specified.

| Symbol | Parameter | Conditions | Min | Typ ^[1] | Max | Unit |
|--------------------------------------|--------------------------|--|----------|--------------------|-----|------|
| Standard I/O pins , RESET pin | | | | | | |
| Input characteristics | | | | | | |
| I _{IL} | LOW-level input current | V _I = 0 V; on-chip pull-up resistor disabled | - | 2 | 200 | nA |
| I _{IH} | HIGH-level input current | V _I = V _{DD} ; on-chip pull-down resistor disabled | - | 2 | 200 | nA |
| V _I | input voltage | pin configured to provide a digital function; | [2] 0 | - | 3.6 | V |

Table 24. Static characteristics: pin characteristics...continued

$T_{amb} = -40\text{ }^{\circ}\text{C}$ to $+105\text{ }^{\circ}\text{C}$, unless otherwise specified. $1.8\text{ V} \leq V_{DD} \leq 3.6\text{ V}$ unless otherwise specified. Values tested in production unless otherwise specified.

| Symbol | Parameter | Conditions | Min | Typ ^[1] | Max | Unit | |
|--|---------------------------|--|---------------------|--------------------|---------------------|------------|----|
| | | $V_{DD} \geq 1.8\text{ V}$ | | | | | |
| V_{IH} | HIGH-level input voltage | | $0.7 \times V_{DD}$ | - | V_{DD} | V | |
| V_{IL} | LOW-level input voltage | | -0.3 | - | $0.3 \times V_{DD}$ | V | |
| V_{hys} | hysteresis voltage | | - | 0.4 | - | V | |
| Output characteristics | | | | | | | |
| V_{OH} | HIGH-level output voltage | $I_{OH} = -4\text{ mA}$; $1.8\text{ V} \leq V_{DD} < 2.7\text{ V}$ | $V_{DD} - 0.5$ | - | - | V | |
| | | $I_{OH} = -4\text{ mA}$; $2.7\text{ V} \leq V_{DD} \leq 3.6\text{ V}$ | $V_{DD} - 0.4$ | - | - | V | |
| V_{OL} | LOW-level output voltage | $I_{OL} = 4\text{ mA}$; $1.8\text{ V} \leq V_{DD} < 2.7\text{ V}$ | - | - | 0.4 | V | |
| | | $I_{OL} = 4\text{ mA}$; $2.7\text{ V} \leq V_{DD} \leq 3.6\text{ V}$ | - | - | 0.4 | V | |
| Weak input pull-up/pull-down characteristics | | | | | | | |
| R_{pd} | pull-down resistance | $V_I = 0$ | 40 | 50 | 62 | k Ω | |
| R_{pu} | pull-up resistance | $V_I = V_{DD}$ | 40 | 50 | 62 | k Ω | |
| Pin capacitance | | | | | | | |
| C_{io} | input/output capacitance | I ² C-bus pins | [3] | - | - | 4.5 | pF |
| | | pins with digital functions only | [4] | - | - | 2.5 | pF |
| | | Pins with digital and analog functions | [4] | - | - | 3.0 | pF |

[1] Typical ratings are not guaranteed. The values listed are at room temperature (25 °C), nominal supply voltage.

[2] With respect to ground.

[3] The value specified is a simulated value, excluding package/bondwire capacitance.

[4] The values specified are simulated and absolute values, including package/bondwire capacitance.

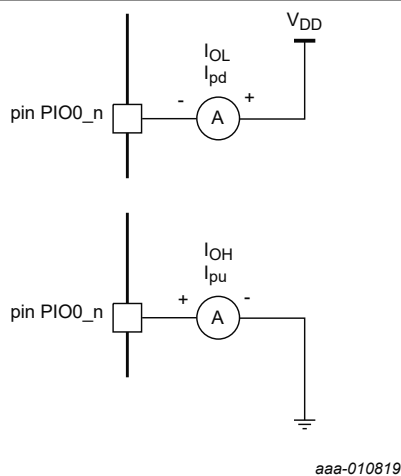
**Figure 13. Pin input/output current measurement**

11 Dynamic characteristics

11.1 Power-up ramp conditions

Table 25. Power-up ramp characteristics

| Symbol | Parameter | Conditions | | Min | Typ | Max | Unit |
|--------|-----------|--|-----|-----|-----|-----|------|
| tr | Rise time | $T_{amb} = -40\text{ }^{\circ}\text{C}$ | [1] | 2.6 | - | - | ms |
| | | $T_{amb} = 0\text{ }^{\circ}\text{C to } +105\text{ }^{\circ}\text{C}$ | [1] | 0.5 | - | - | ms |

[1] Based on characterization, not tested in production.

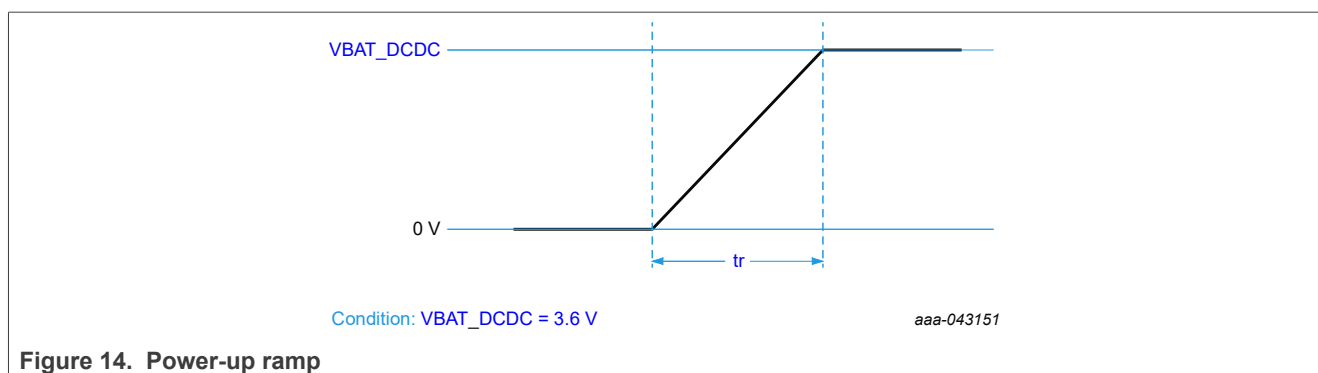

11.2 Flash memory

Table 26. Flash characteristics^[1]

$T_{amb} = -40\text{ }^{\circ}\text{C to } +105\text{ }^{\circ}\text{C}$, unless otherwise specified.

| Symbol | Parameter | Conditions | | Min | Typ ^[2] | Max | Unit |
|-------------------|------------------------|---|-----|--------|--------------------|-----|---------|
| N _{endu} | endurance | Page erase/program, $T_{amb} = -40\text{ }^{\circ}\text{C to } +85\text{ }^{\circ}\text{C}$ | [3] | 100000 | - | - | cycles |
| | | Mass erase/program, $T_{amb} = -40\text{ }^{\circ}\text{C to } +85\text{ }^{\circ}\text{C}$ | | 100000 | - | - | cycles |
| | | Page erase/program $T_{amb} = -40\text{ }^{\circ}\text{C to } +105\text{ }^{\circ}\text{C}$, | | 10000 | - | - | cycles |
| | | Mass erase/program $T_{amb} = -40\text{ }^{\circ}\text{C to } +105\text{ }^{\circ}\text{C}$, | | 10000 | - | - | cycles |
| t _{ret} | retention time | < 1k erase/program cycles | | 25 | 100 | - | years |
| | | ≥ 1k erase/program cycles | | 15 | 50 | - | years |
| t _{er} | erase time | 1 page or multiple pages | | - | 2.0 | - | ms |
| t _{prog} | programming time | | | - | 1.09 | - | ms |
| Nupdates | number of page updates | 1 page or multiple pages | | - | - | 50 | million |

[1] Flash operations (erase, blank check, program) and reading single word can only be performed for CPU frequencies of up to 100 MHz. Cannot be performed for frequencies above 100 MHz.

[2] Temperature = 25 C.

[3] Number of erase/program cycles.

11.3 I/O pins

Table 27. Dynamic characteristic: I/O pins^[1]

$T_{amb} = -40\text{ °C to }+105\text{ °C}; 1.8\text{ V} \leq V_{DD} \leq 3.6\text{ V}$

| Symbol | Parameter | Conditions | | Min | Typ | Max | Unit |
|--|-----------|------------------------------------|--------|------|-----|------|------|
| Standard I/O pins - normal drive strength | | | | | | | |
| t_r | rise time | pin configured as output; SLEW = 1 | [2][3] | 2.0 | - | 4.0 | ns |
| t_f | fall time | pin configured as output; SLEW = 1 | [2][3] | 2.0 | - | 4.0 | ns |
| t_r | rise time | pin configured as output; SLEW = 0 | [2][3] | 1.2 | - | 11.0 | ns |
| t_f | fall time | pin configured as output; SLEW = 0 | [2][3] | 3.9 | - | 9.0 | ns |
| I2C I/O pins - normal drive strength | | | | | | | |
| t_r | rise time | pin configured as output; SLEW = 1 | [2][3] | 3.0 | - | 11.0 | ns |
| t_f | fall time | pin configured as output; SLEW = 1 | [2][3] | 3.0 | - | 7.0 | ns |
| t_r | rise time | pin configured as output; SLEW = 0 | [2][3] | 21.5 | - | 39.0 | ns |
| t_f | fall time | pin configured as output; SLEW = 0 | [2][3] | 29.8 | - | 36.0 | ns |

[1] Based on characterized, not tested in production

[2] Rise and fall times measured between 90% and 10% of the full input signal level.

[3] The slew rate is configured in the IOCON block the SLEW bit. See the LPC55S6x user manual.

11.4 Wake-up process

Table 28. Dynamic characteristic: Typical wake-up times from low power modes

$V_{BAT_PMU} = V_{BAT_DCDC} = V_{DD} = 3.3\text{ V}; T_{amb} = 25\text{ °C};$ using FRO as the system clock.

| Symbol | Parameter | Conditions | | Min | Typ ^{[1][2]} | Max | Unit |
|------------|--------------|---|--------|-----|-----------------------|-----|------|
| t_{wake} | wake-up time | from Sleep mode, 12 MHz, No PRIMASK backup and restore | [3][4] | | 4.0 | | μs |
| | | from Sleep mode, 96 MHz, No PRIMASK backup and restore | [3][4] | | 500 | | ns |
| | | from Deep-sleep mode with full SRAM retention: | [3] | | 64 | | μs |
| | | from Power-down mode with CPU retention and 4 KB retained | [3] | | 346 | | μs |
| | | from deep power-down mode; 4KB retained, RTC disabled; using RESET pin. | [5][6] | | 4.6 | | ms |
| | | from deep power-down mode; 4KB retained, RTC disabled; using RESET pin. | [5][7] | | 17 | | ms |

[1] Typical ratings are not guaranteed. The values listed are at room temperature (25 °C), nominal supply voltages.

[2] Compiler settings: IAR v8.40, High optimization

[3] The wake-up time measured is the time between when a GPIO input pin is triggered to wake the device up from the low power modes and from when a GPIO output pin is set in the interrupt service routine (ISR) wake-up handler.

[4] FRO enabled, all peripherals off.

[5] RTC disabled. Wake-up from deep power-down causes the part to go through entire reset process. The wake-up time measured is the time between when the RESET pin is triggered to wake the device up and when a GPIO output pin is set in the reset handler. Wake-up time for non-secure mode.

[6] Applies to device revision 1B.

[7] Applies to device revision 0A.

11.5 FRO (12 MHz/96 MHz)

Table 29. Dynamic characteristic: FRO

$T_{amb} = -40\text{ °C to }+105\text{ °C}; 1.8\text{ V} \leq VBAT_DCDC \leq 3.6\text{ V}.$

| Symbol | Parameter | Conditions | Min | Typ ^[1] | Max | Unit |
|---------------|---------------------|------------|-------|--------------------|-------|------|
| $f_{osc(RC)}$ | FRO clock frequency | - | 11.76 | 12 | 12.24 | MHz |
| $f_{osc(RC)}$ | FRO clock frequency | - | 94.08 | 96 | 97.92 | MHz |

[1] Typical ratings are not guaranteed. The values listed are at room temperature (25 °C), nominal supply voltages.

Table 30. Dynamic characteristic: FRO ^[1]

$T_{amb} = 0\text{ °C to }+85\text{ °C}; 1.8\text{ V} \leq VBAT_DCDC \leq 3.6\text{ V}.$

| Symbol | Parameter | Conditions | Min | Typ ^[2] | Max | Unit |
|---------------|---------------------|------------|-------|--------------------|-------|------|
| $f_{osc(RC)}$ | FRO clock frequency | - | 11.88 | 12 | 12.12 | MHz |
| $f_{osc(RC)}$ | FRO clock frequency | - | 95.04 | 96 | 96.96 | MHz |

[1] The +/- 1% accuracy specification applies to devices with date code 2041 (yyww) and onwards.

[2] Typical ratings are not guaranteed. The values listed are at room temperature (25 °C), nominal supply voltages.

11.6 FRO (1 MHz)

Table 31. Dynamic characteristic: FRO

$T_{amb} = -40\text{ °C to }+105\text{ °C}; 1.8\text{ V} \leq VBAT_DCDC \leq 3.6\text{ V}.$

| Symbol | Parameter | Conditions | Min | Typ ^[1] | Max | Unit |
|---------------|---------------------|------------|------|--------------------|------|------|
| $f_{osc(RC)}$ | FRO clock frequency | - | 0.85 | 1 | 1.15 | MHz |

[1] Typical ratings are not guaranteed. The values listed are at room temperature (25 °C), nominal supply voltages.

11.7 FRO (32 KHz)

Table 32. Dynamic characteristic: FRO

$T_{amb} = -40\text{ °C to }+105\text{ °C}; 1.8\text{ V} \leq VBAT_DCDC \leq 3.6\text{ V}.$

| Symbol | Parameter | Conditions | Min | Typ ^[1] | Max | Unit |
|---------------|---------------------|------------|-------|--------------------|-------|------|
| $f_{osc(RC)}$ | FRO clock frequency | - | 32.11 | 32.768 | 33.42 | KHz |

[1] Typical ratings are not guaranteed. The values listed are at room temperature (25 °C), nominal supply voltages.

11.8 RTC oscillator

See [Section 13.4](#) for connecting the RTC oscillator to an external clock source.

Table 33. Dynamic characteristic: RTC oscillator

$T_{amb} = -40\text{ °C to }+105\text{ °C}; 1.8 \leq VBAT_DCDC \leq 3.6$ ^[1]

| Symbol | Parameter | Conditions | Min | Typ ^[1] | Max | Unit |
|--------|-----------------|------------|-----|--------------------|-----|------|
| f_i | input frequency | - | - | 32.768 | | KHz |

[1] Parameters are valid over operating temperature range unless otherwise specified.

11.9 I²C-bus

Table 34. Dynamic characteristic: I²C-bus pins^[1]

$T_{amb} = -40\text{ °C to }+105\text{ °C}; 1.8\text{ V} \leq V_{BAT_DCDC} \leq 3.6\text{ V}$.^[2]

| Symbol | Parameter | | Conditions | Min | Max | Unit |
|---------------------|------------------------------|--------------|--|---------------------------|-----|------|
| f _{SCL} | SCL clock frequency | | Standard-mode | 0 | 100 | kHz |
| | | | Fast-mode | 0 | 400 | kHz |
| | | | Fast-mode Plus | 0 | 1 | MHz |
| t _f | fall time | [3][4][5][6] | of both SDA and SCL signals Standard-mode | - | 300 | ns |
| | | | Fast-mode | 20 + 0.1 × C _b | 300 | ns |
| | | | Fast-mode Plus | - | 120 | ns |
| t _{LOW} | LOW period of the SCL clock | | Standard-mode | 4.7 | - | μs |
| | | | Fast-mode | 1.3 | - | μs |
| | | | Fast-mode Plus | 0.5 | - | μs |
| t _{HIGH} | HIGH period of the SCL clock | | Standard-mode | 4.0 | - | μs |
| | | | Fast-mode | 0.6 | - | μs |
| | | | Fast-mode Plus | 0.26 | - | μs |
| t _{HD;DAT} | data hold time | [7][3][8] | Standard-mode | 0 | - | μs |
| | | | Fast-mode | 0 | - | μs |
| | | | Fast-mode Plus | 0 | - | μs |
| t _{SU;DAT} | data set-up time | [9][10] | Standard-mode | 250 | - | ns |
| | | | Fast-mode | 100 | - | ns |
| | | | Fast-mode Plus | 50 | - | ns |

[1] Guaranteed by design. Not tested in production.

[2] Parameters are valid over operating temperature range unless otherwise specified. See the I²C-bus specification *UM10204* for details.

[3] A device must internally provide a hold time of at least 300 ns for the SDA signal (with respect to the V_{IH(min)} of the SCL signal) to bridge the undefined region of the falling edge of SCL.

[4] C_b = total capacitance of one bus line in pF. If mixed with Hs-mode devices, faster fall times are allowed.

[5] The maximum t_f for the SDA and SCL bus lines is specified at 300 ns. The maximum fall time for the SDA output stage t_f is specified at 250 ns. This allows series protection resistors to be connected in between the SDA and the SCL pins and the SDA/SCL bus lines without exceeding the maximum specified t_f.

[6] In Fast-mode Plus, fall time is specified the same for both output stage and bus timing. If series resistors are used, designers should allow for this when considering bus timing.

[7] t_{HD;DAT} is the data hold time that is measured from the falling edge of SCL; applies to data in transmission and the acknowledge.

[8] The maximum t_{HD;DAT} could be 3.45 μs and 0.9 μs for Standard-mode and Fast-mode but must be less than the maximum of t_{VD;DAT} or t_{VD;ACK} by a transition time. This maximum must only be met if the device does not stretch the LOW period (t_{LOW}) of the SCL signal. If the clock stretches the SCL, the data must be valid by the set-up time before it releases the clock.

[9] t_{SU;DAT} is the data set-up time that is measured with respect to the rising edge of SCL; applies to data in transmission and the acknowledge.

[10] A Fast-mode I²C-bus device can be used in a Standard-mode I²C-bus system but the requirement t_{SU;DAT} = 250 ns must then be met. This will automatically be the case if the device does not stretch the LOW period of the SCL signal. If such a device does stretch the LOW period of the SCL signal, it must output the next data bit to the SDA line t_{r(max)} + t_{SU;DAT} = 1000 + 250 = 1250 ns (according to the Standard-mode I²C-bus specification) before the SCL line is released. Also the acknowledge timing must meet this set-up time.

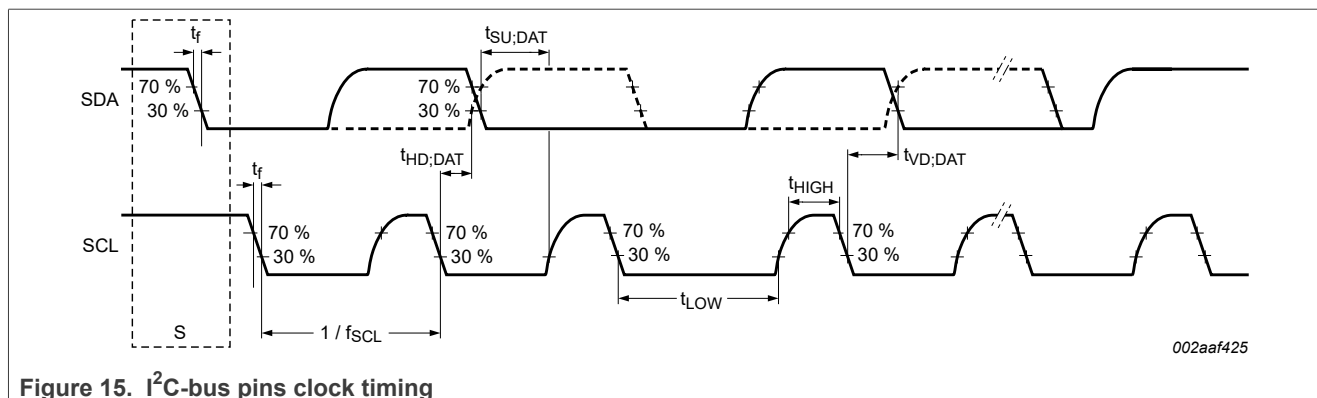
Figure 15. I²C-bus pins clock timing

11.10 I²S-bus interface

Table 35. Dynamic characteristics: I²S-bus interface pins ^{[1][4]}

$T_{amb} = -40\text{ °C to }105\text{ °C}$; $V_{BAT_DCDC} = 1.8\text{ V to }3.6\text{ V}$; $C_L = 10\text{ pF}$ balanced loading on all pins; Input slew = 1.0 ns, SLEW setting = standard mode for all pins; Parameters sampled at the 50% level of the rising or falling edge.

| Symbol | Parameter | Conditions | Min | Typ ^[3] | Max | Unit |
|---------------------------------------|------------------------|--|-----|--------------------|-----|-----------|
| Common to master and slave | | | | | | |
| t_{WH} | pulse width HIGH | on pins I2Sx_TX_SCK and I2Sx_RX_SCK ^[5] | 45% | - | 55% | T_{cyc} |
| t_{WL} | pulse width LOW | on pins I2Sx_TX_SCK and I2Sx_RX_SCK ^[5] | 45% | - | 55% | T_{cyc} |
| Master; 1.8 V ≤ VDD < 3.6 V | | | | | | |
| $t_{V(Q)}$ | data output valid time | on pin I2Sx_TX_SDA ^[2] | 5 | - | 15 | ns |
| | | on pin I2Sx_WS | 5 | - | 12 | ns |
| $t_{su(D)}$ | data input set-up time | on pin I2Sx_RX_SDA ^[2] | 4 | - | - | ns |
| $t_{h(D)}$ | data input hold time | on pin I2Sx_RX_SDA ^[2] | 0 | - | - | ns |
| Slave; 1.8 V ≤ VDD < 3.6 V | | | | | | |
| $t_{V(Q)}$ | data output valid time | on pin I2Sx_TX_SDA ^[2] | 9 | - | 26 | ns |
| $t_{su(D)}$ | data input set-up time | on pin I2Sx_RX_SDA ^[2] | 4 | - | - | ns |
| | | on pin I2Sx_WS | 4 | - | - | ns |
| $t_{h(D)}$ | data input hold time | on pin I2Sx_RX_SDA ^[2] | 0 | - | - | ns |

Table 35. Dynamic characteristics: I²S-bus interface pins ^{[1][4]} ...continued

$T_{amb} = -40\text{ °C to }105\text{ °C}$; $V_{BAT_DCDC} = 1.8\text{ V to }3.6\text{ V}$; $C_L = 10\text{ pF}$ balanced loading on all pins; Input slew = 1.0 ns, SLEW setting = standard mode for all pins; Parameters sampled at the 50% level of the rising or falling edge.

| Symbol | Parameter | Conditions | Min | Typ ^[3] | Max | Unit |
|--------|-----------|----------------|-----|--------------------|-----|------|
| | | on pin I2Sx_WS | 0 | - | - | ns |

1. Based on simulation; not tested in production.
2. Clock Divider register (DIV) = 0x0.
3. Typical ratings are not guaranteed.
4. The Flexcomm Interface function clock frequency should not be above 48 MHz. See the data rates section in the I²S chapter (UM11126) to calculate clock and sample rates.
5. Based on simulation. Not tested in production.

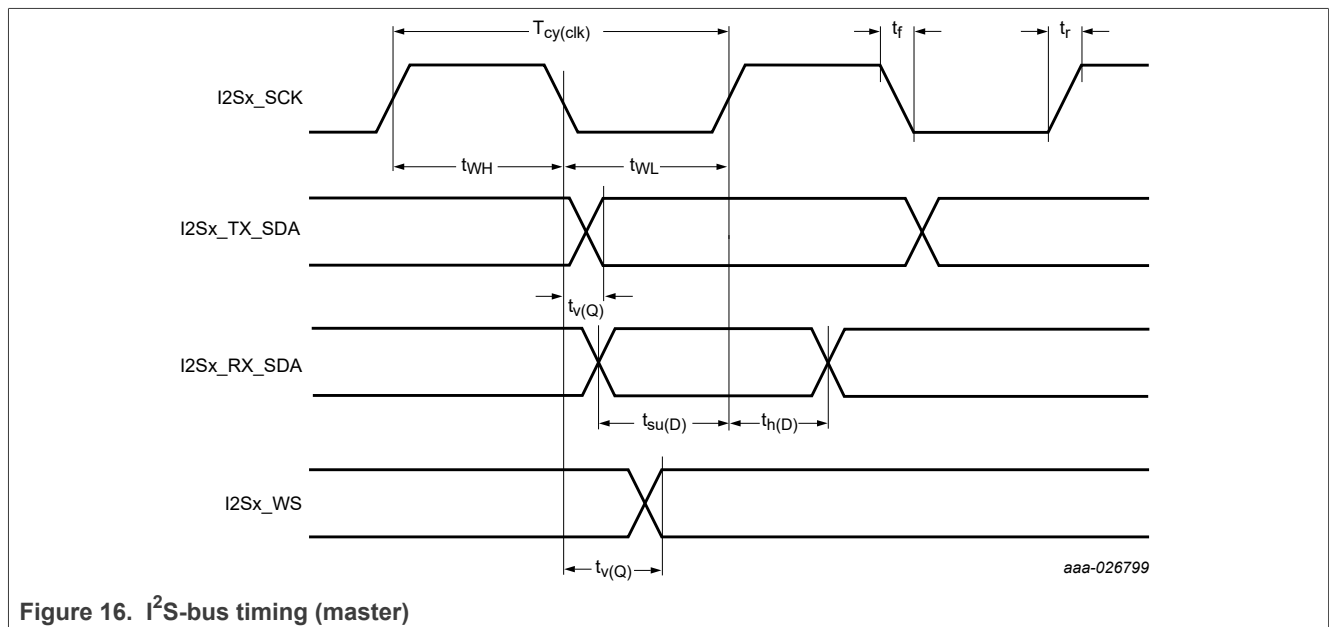

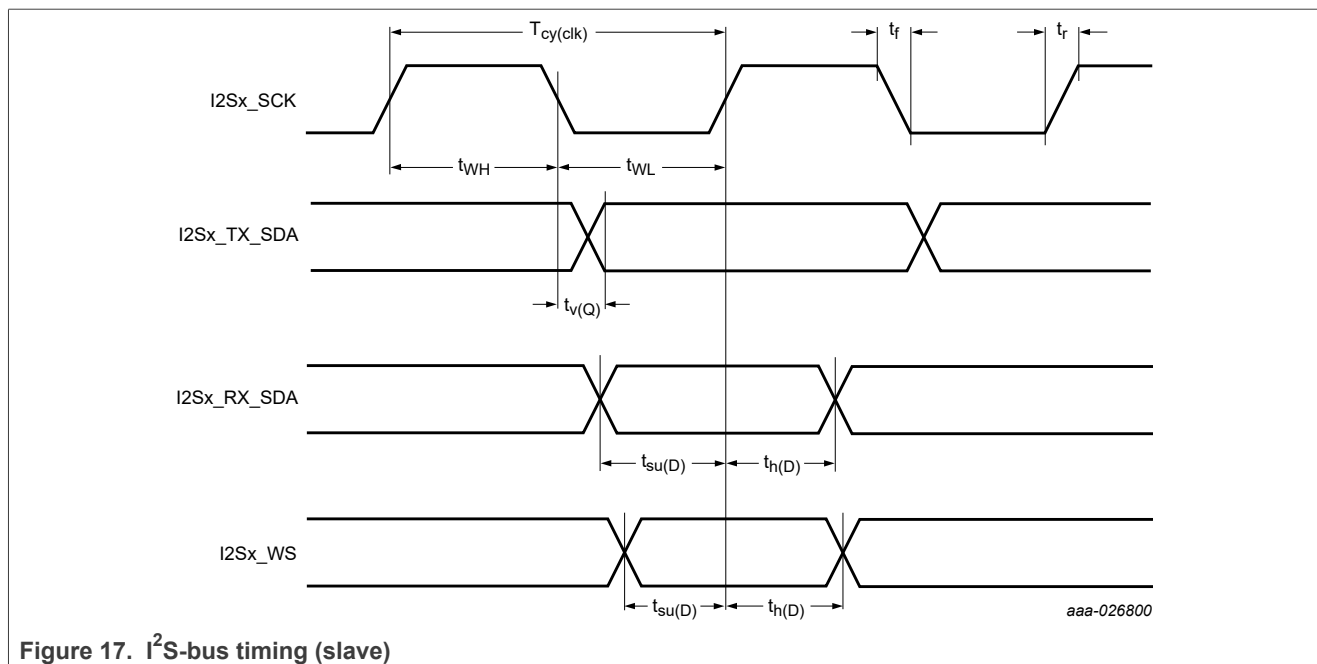
Figure 17. I²S-bus timing (slave)

11.11 SPI interface (Flexcomm Interfaces 0 - 7)

The actual SPI bit rate depends on the delays introduced by the external trace, the external device, system clock (CCLK), and capacitive loading. Excluding delays introduced by external device and PCB, the maximum supported bit rate for SPI master mode (transmit/receive) is 32 Mbit/s. Excluding delays introduced by external device and PCB, the maximum supported bit rate for SPI slave receive mode is 50 Mbit/s and for slave transmit mode is 16 Mbit/s.

Table 36. SPI dynamic characteristics^[1]

$T_{amb} = -40\text{ }^{\circ}\text{C}$ to $105\text{ }^{\circ}\text{C}$; $V_{DD} = 1.8\text{ V}$ to 3.6 V ; $C_L = 10\text{ pF}$ balanced loading on all pins; Input slew = 1 ns , SLEW setting = fast mode for all pins; Parameters sampled at the 50% level of the rising or falling edge.

| Symbol | Parameter | Conditions | Min | Typ | Max | Unit |
|-------------------|------------------------|------------|-----|-----|-----|------|
| SPI master | | | | | | |
| t_{DS} | data set-up time | | 5 | - | - | ns |
| t_{DH} | data hold time | | 0 | - | - | ns |
| $t_{V(Q)}$ | data output valid time | | 5 | - | 13 | ns |
| SPI slave | | | | | | |
| t_{DS} | data set-up time | | 5 | - | - | ns |
| t_{DH} | data hold time | | 0 | - | - | ns |
| $t_{V(Q)}$ | data output valid time | | 8 | - | 21 | ns |

[1] Based on simulated values. Not tested in production

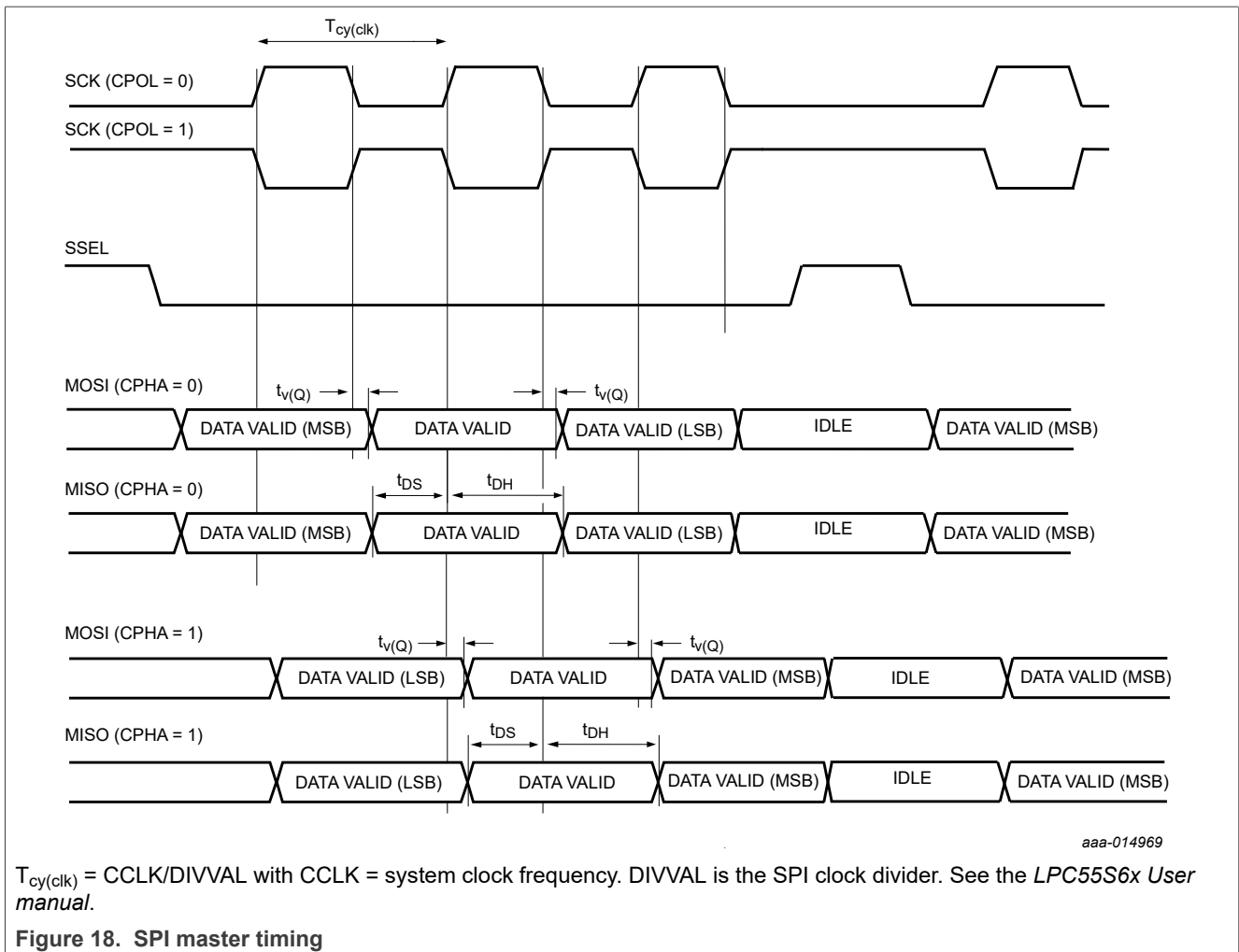

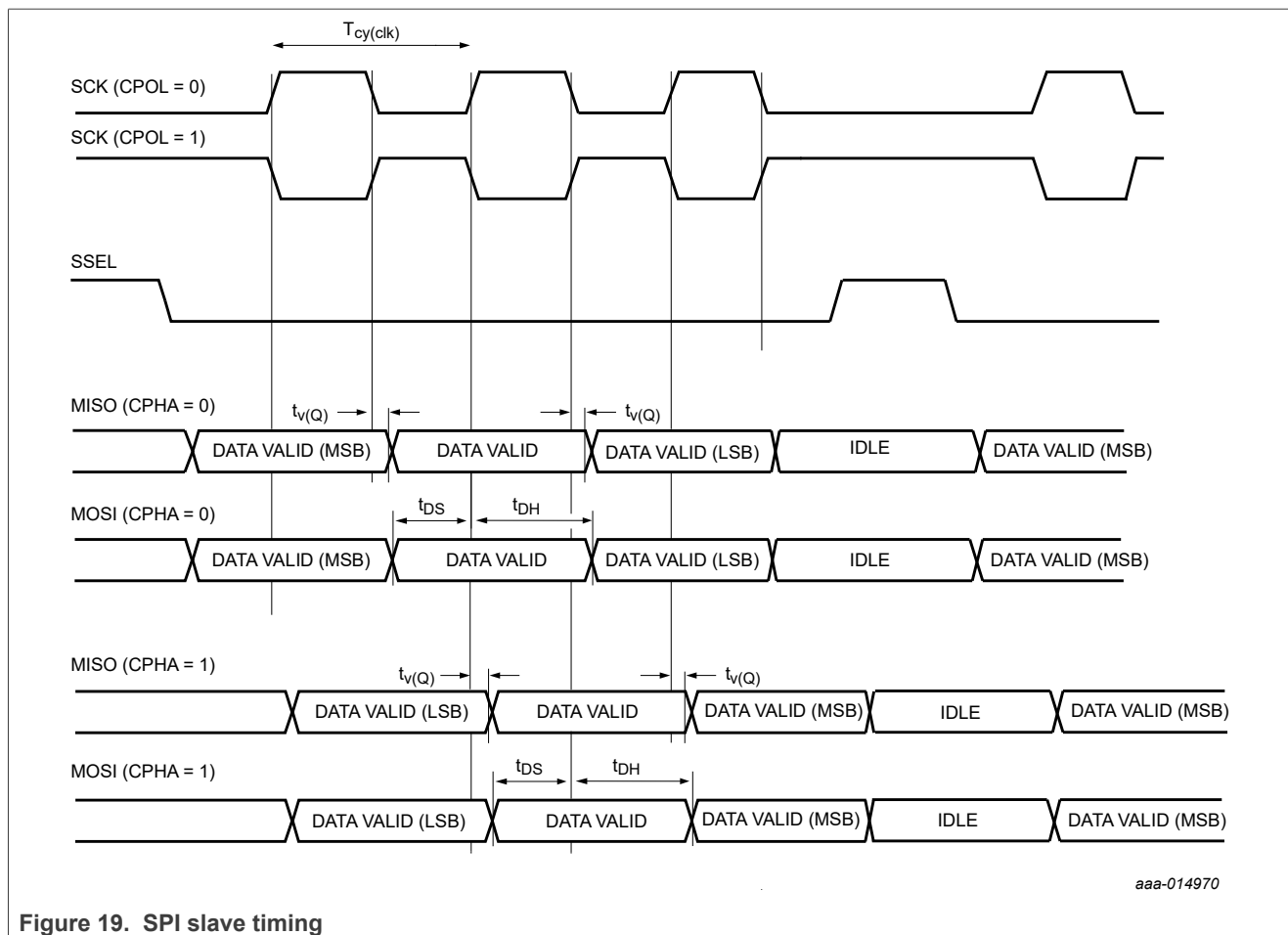

Figure 19. SPI slave timing

11.12 High-Speed SPI interface (Flexcomm Interface 8)

The actual SPI bit rate depends on the delays introduced by the external trace, the external device, system clock (CCLK), and capacitive loading. Excluding delays introduced by external device and PCB, the maximum supported bit rate for SPI master mode (transmit/receive) is 50 Mbit/s. Excluding delays introduced by external device and PCB, the maximum supported bit rate for SPI slave receive mode is 50 Mbit/s and for SPI slave transmit mode is 25 Mbit/s.

Table 37. SPI dynamic characteristics^[1]

$T_{amb} = -40\text{ }^{\circ}\text{C}$ to $105\text{ }^{\circ}\text{C}$; $V_{DD} = 1.8\text{ V}$ to 3.6 V ; $C_L = 10\text{ pF}$ balanced loading on all pins; Input slew = 1 ns , SLEW setting = fast mode for all pins;. Parameters sampled at the 50% level of the rising or falling edge.

| Symbol | Parameter | Conditions | Min | Typ | Max | Unit |
|-------------------|------------------------|------------|-----|-----|-----|------|
| SPI master | | | | | | |
| t_{DS} | data set-up time | | 4 | - | - | ns |
| t_{DH} | data hold time | | 0 | - | - | ns |
| $t_{v(Q)}$ | data output valid time | | 3 | - | 8 | ns |
| SPI slave | | | | | | |
| t_{DS} | data set-up time | | 4 | - | - | ns |
| t_{DH} | data hold time | | 0 | - | - | ns |

Table 37. SPI dynamic characteristics^[1]...continued

$T_{amb} = -40\text{ }^{\circ}\text{C}$ to $105\text{ }^{\circ}\text{C}$; $V_{DD} = 1.8\text{ V}$ to 3.6 V ; $C_L = 10\text{ pF}$ balanced loading on all pins; Input slew = 1 ns , SLEW setting = fast mode for all pins; Parameters sampled at the 50% level of the rising or falling edge.

| Symbol | Parameter | Conditions | Min | Typ | Max | Unit |
|------------|------------------------|------------|-----|-----|-----|------|
| $t_{v(Q)}$ | data output valid time | | 6 | - | 15 | ns |

[1] Based on simulated values. Not tested in production.

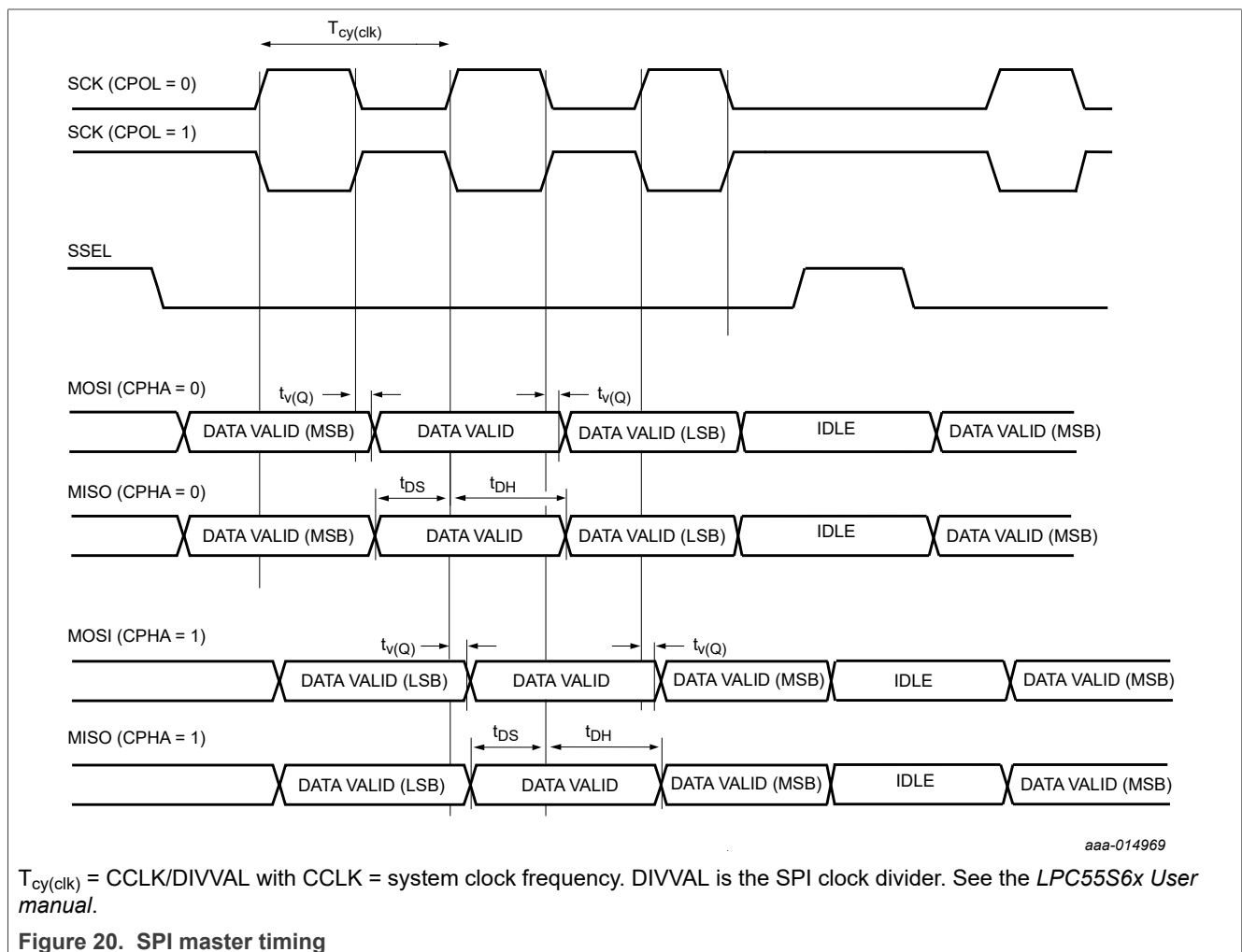

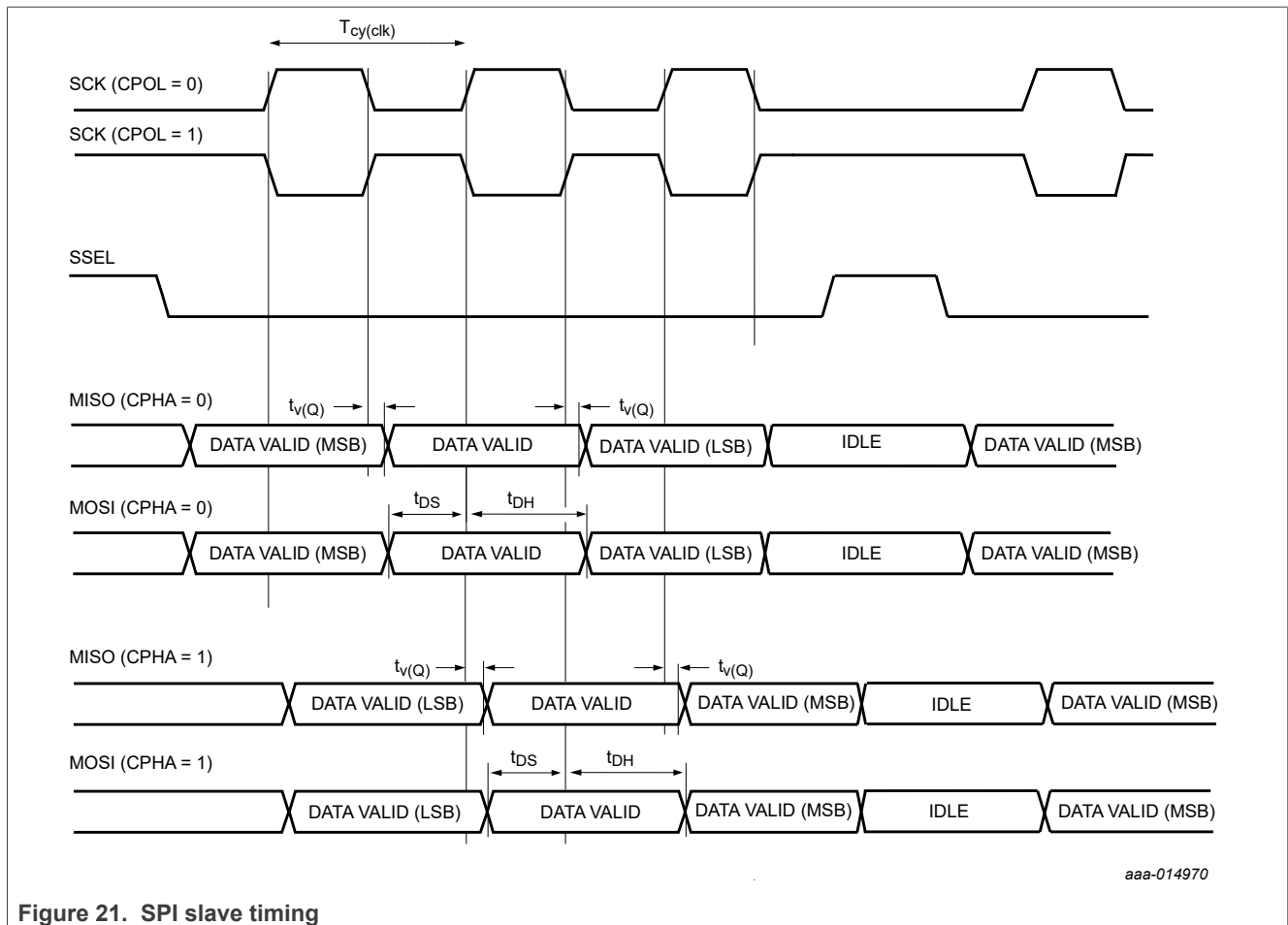

Figure 21. SPI slave timing

11.13 USART interface

The actual USART bit rate depends on the delays introduced by the external trace, the external device, system clock (CCLK), and capacitive loading. Excluding delays introduced by external device and PCB, the maximum supported bit rate for USART master and slave synchronous mode is 25 Mbit/s. Excluding delays introduced by external device and PCB, the maximum supported bit rate for USART master and slave asynchronous mode is 10 Mbit/s.

Table 38. USART dynamic characteristics^[1]

$T_{amb} = -40\text{ }^{\circ}\text{C}$ to $105\text{ }^{\circ}\text{C}$; $V_{DD} = 1.8\text{ V}$ to 3.6 V ; $C_L = 10\text{ pF}$ balanced loading on all pins; Input slew = 1 ns , SLEW setting = fast-mode for all pins; Parameters sampled at the 50% level of the rising or falling edge.

| Symbol | Parameter | Conditions | Min | Typ | Max | Unit |
|---|------------------------|------------|-----|-----|-----|------|
| USART master (in synchronous mode) | | | | | | |
| $t_{su(D)}$ | data input set-up time | | 6 | - | - | ns |
| $t_{h(D)}$ | data input hold time | | 0 | - | - | ns |
| $t_{v(Q)}$ | data output valid time | | 5 | - | 11 | ns |
| USART slave (in synchronous mode) | | | | | | |
| $t_{su(D)}$ | data input set-up time | | 6 | - | - | ns |
| $t_{h(D)}$ | data input hold time | | 0 | - | - | ns |

Table 38. USART dynamic characteristics^[1]...continued

$T_{amb} = -40\text{ °C to }105\text{ °C}$; $V_{DD} = 1.8\text{ V to }3.6\text{ V}$; $C_L = 10\text{ pF}$ balanced loading on all pins; Input slew = 1 ns, SLEW setting = fast-mode for all pins; Parameters sampled at the 50% level of the rising or falling edge.

| Symbol | Parameter | Conditions | Min | Typ | Max | Unit |
|------------|------------------------|------------|-----|-----|-----|------|
| $t_{v(Q)}$ | data output valid time | | 9 | - | 25 | ns |

[1] Based on simulated values. Not tested in production.

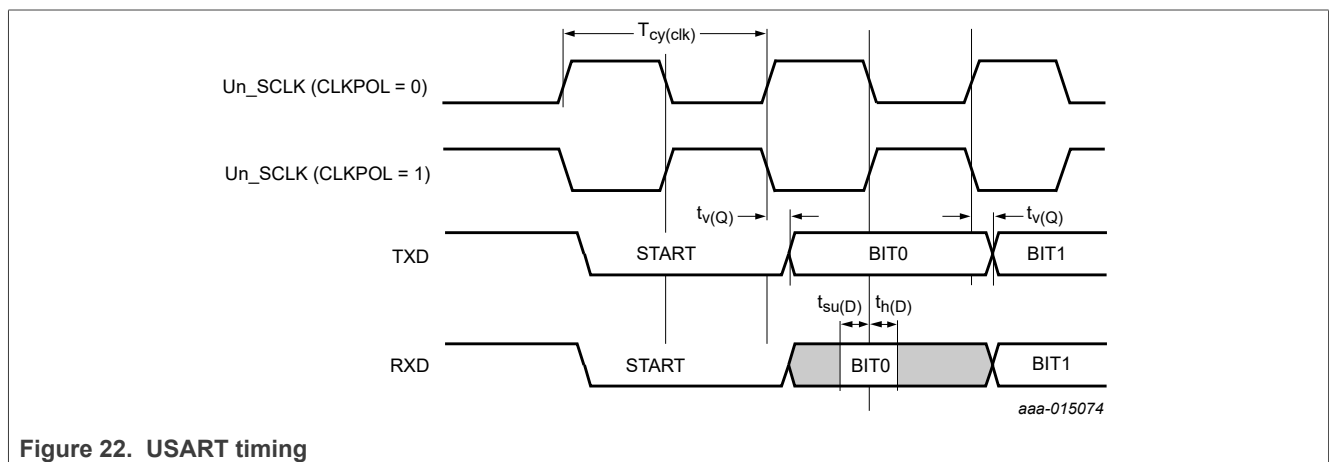
**Figure 22. USART timing**

11.14 SD/MMC and SDIO

Table 39. Dynamic characteristics: SD/MMC and SDIO

$T_{amb} = -40\text{ °C to }+105\text{ °C}$, $V_{DD} = 1.8\text{ V to }3.6\text{ V}$; $C_L = 10\text{ pF}$. $SAMPLE_DELAY = 0$, $DRV_DELAY = 0$ in the $SDDELAY$ register, $SDIOCLKCTRL = 0x84$, sampled at 90 % and 10 % of the signal level, $SLEW = 1\text{ ns}$ for SD_CLK pin, $SLEW = 1\text{ ns}$ for SD_DATn and SD_CMD pins. Simulated values in high-speed mode. Not tested in production.

| Symbol | Parameter | Conditions | Min | Typ | Max | Unit |
|-------------|------------------------|---------------------------------------|-----|-----|-----|------|
| f_{clk} | clock frequency | on pin SD_CLK ; data transfer mode | - | - | 50 | MHz |
| $t_{su(D)}$ | data input set-up time | on pins SD_DATn as inputs | 15 | - | - | ns |
| | | on pins SD_CMD as inputs | 15 | - | - | ns |
| $t_{h(D)}$ | data input hold time | on pins SD_DATn as inputs | 0 | - | - | ns |
| | | on pins SD_CMD as inputs | 0 | - | - | ns |
| $t_{v(Q)}$ | data output valid time | on pins SD_DATn as outputs | 3 | - | 7 | ns |
| | | on pins SD_CMD as outputs | 3 | - | 7 | ns |

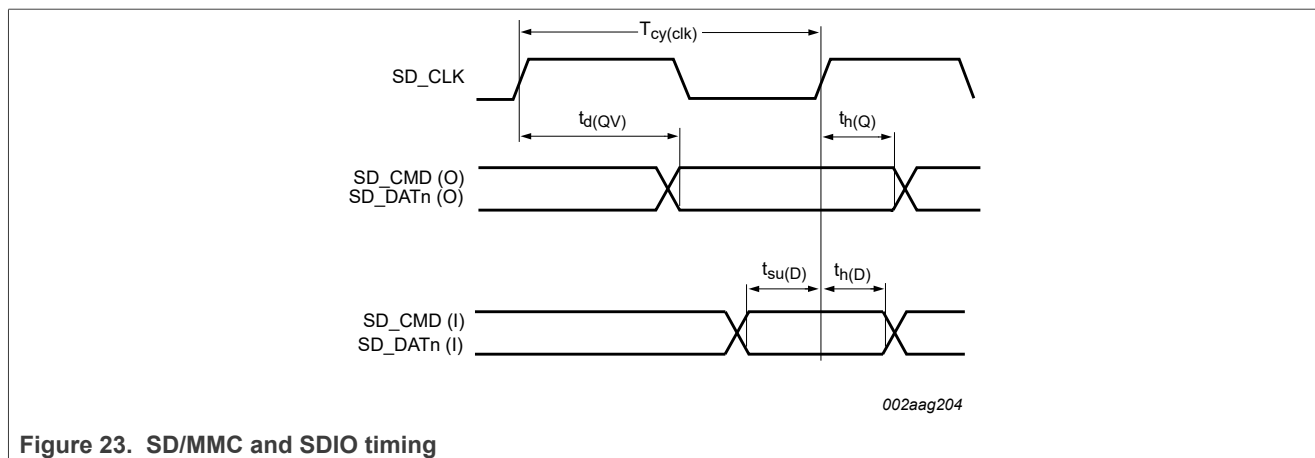

Figure 23. SD/MMC and SDIO timing

Definitions:

- Delay_O=cclk_in to cclk_out delay (including PAD).
- Delay_I=Input PAD delay + routing delay to input register.

Table 40. Minimum and Maximum values of parameters

| Parameters | Minimum | Maximum |
|------------|---------|---------|
| Delay_O | - | 8nS |
| Delay_I | - | 6nS |

12 Analog characteristics

12.1 BODVBAT

Brown-out detector to monitor the voltage of VBAT. If the voltage falls below one of the selected voltages, the BOD asserts an interrupt to the NVIC or issues a reset. Single low threshold detection level (programmable trip low level) is used for either BOD interrupt or BOD reset. Hysteresis control on the BOD is programmable. Please refer to UM11126 for further details.

Table 41. BOD static characteristics

$T_{amb} = 25\text{ }^{\circ}\text{C}$; based on characterization; not tested in production. Please refer to UM11126 for further details.

| Symbol | Parameter | Conditions | Min | Typ | Max | Unit |
|----------|-----------------------------|------------|-----|------|-----|------|
| V_{th} | threshold voltage (TRIGLVL) | | - | 1.75 | - | V |
| | | | - | 1.80 | - | V |
| | | | - | 1.90 | - | V |
| | | | - | 2.00 | - | V |
| | | | - | 2.10 | - | V |
| | | | - | 2.20 | - | V |
| | | | - | 2.30 | - | V |
| | | | - | 2.40 | - | V |
| | | | - | 2.50 | - | V |

Table 41. BOD static characteristics...continued

$T_{amb} = 25\text{ °C}$; based on characterization; not tested in production. Please refer to UM11126 for further details.

| Symbol | Parameter | Conditions | Min | Typ | Max | Unit |
|--------|-----------|------------|-----|------|-----|------|
| | | | - | 2.60 | - | V |
| | | | - | 2.70 | - | V |
| | | | - | 2.80 | - | V |
| | | | - | 2.90 | - | V |
| | | | - | 3.00 | - | V |
| | | | - | 3.10 | - | V |
| | | | - | 3.20 | - | V |
| | | | - | 3.30 | - | V |

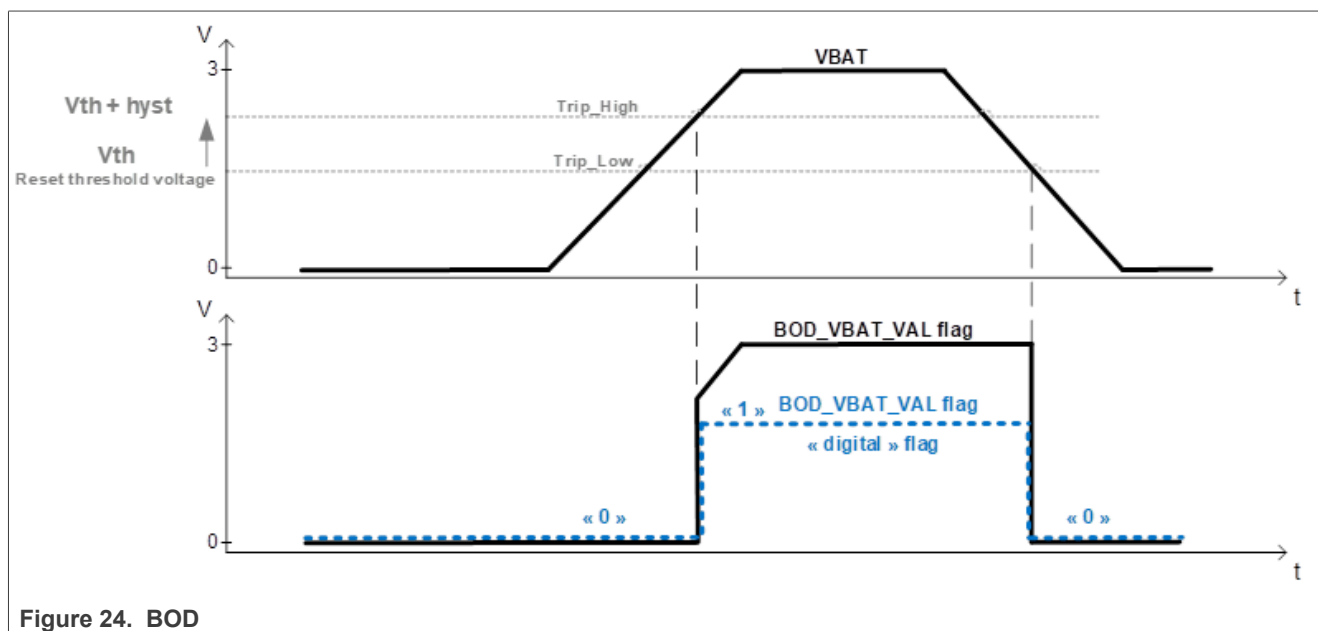

Figure 24. BOD

12.2 16-bit ADC characteristics

Table 42. 16-bit ADC static characteristics

$T_{amb} = -40\text{ °C}$ to $+105\text{ °C}$; $V_{DDA} = 1.8\text{ V}$ to 3.6 V ; ADC calibrated at $T = 25\text{ °C}$.

| Symbol | Parameter | Conditions | Min ^[1] | Typ ^[1] | Max ^[1] | Unit |
|----------------|----------------------|------------|--------------------|--------------------|--------------------|------------|
| V_{IA} | analog input voltage | | 0 | - | V_{DDA} | V |
| CADIN | input capacitance | | - | 4 | 5 | pF |
| $f_{clk(ADC)}$ | ADC clock frequency | | [2] | - | 24 | MHz |
| f_s | sampling frequency | | - | - | 1.0 | Msamples/s |

Table 42. 16-bit ADC static characteristics...continued

 $T_{amb} = -40\text{ °C to }+105\text{ °C}$; $V_{DDA} = 1.8\text{ V to }3.6\text{ V}$; ADC calibrated at $T = 25\text{ °C}$.

| Symbol | Parameter | Conditions | | Min ^[1] | Typ ^[1] | Max ^[1] | Unit |
|----------------------|----------------------------------|---|--|--------------------|--------------------|--------------------|------|
| E _D | differential linearity error | 16-bit differential mode, CTYPE = 2 | ^[3] ^[1] ^[4] ^[5] ^[6] | -0.99 | - | 2.6 | LSB |
| | | 16-bit single ended mode, CTYPE = 1 | ^[3] ^[1] ^[4] ^[5] ^[6] | -1 | - | +9.5 | LSB |
| E _{L(adj)} | integral non-linearity | 16-bit differential mode, CTYPE = 2 | ^[3] ^[1] ^[4] ^[5] ^[7] | -16 | - | +16 | LSB |
| | | 16-bit single ended mode, CTYPE = 1 | ^[3] ^[1] ^[4] ^[5] ^[7] | -12 | - | +12 | LSB |
| E _O | offset error | uncalibrated | ^[3] ^[8] | - | 2.3 | - | mV |
| V _{err(FS)} | full-scale error voltage | uncalibrated | ^[3] ^[9] | - | 24 | - | LSB |
| ENOB | [L:] Effective number of bits | 16-bit differential mode, CTYPE = 2 | ^[10] | - | 12.6 | - | bits |
| | | 16-bit single ended mode, CTYPE = 1 | ^[10] | - | 12.0 | - | bits |
| THD | [L:] Total Harmonic Distortion | 16-bit differential mode, CTYPE = 2 | ^[10] | - | -85 | - | dB |
| | | 16-bit single ended mode, CTYPE = 1 | ^[10] | - | -85 | - | dB |
| SFDR | [L:] Spurious Free Dynamic Range | 16-bit differential mode, CTYPE = 2 | ^[10] | - | 86 | - | dB |
| | | 16-bit single ended mode, CTYPE = 1 | ^[10] | - | 82 | - | dB |
| tADCSTUP | Analog startup time | Wait time after setting ADC_CTRL[ADCEN] ^[10] | ^[11] | - | 5 | - | us |

[1] These are typical values and are not guaranteed. Based on characterization. Not tested in production. If VREFP is less than VDDA, then voltage inputs greater than VREFP and less than VDDA are allowed but result in a full scale conversion result.

[2] To use temperature sensor, the maximum fclk(ADC) frequency is 6 MHz.

[3] Linear data collected using a linear histogram technique.

[4] $f_{clk(ADC)} = 24\text{ MHz}$, STS = 3, Power select = 1, Average setting = 1, $f_s = 1\text{ Msample/s}$

[5] Differential linear results assume offset 0.2% from VREFL and 0.2% from VREFH

[6] The differential linearity error (E_D) is the difference between the actual step width and the ideal step width.

[7] The integral non-linearity (E_{L(adj)}) is the peak difference between the center of the steps of the actual and the ideal transfer curve after appropriate adjustment of gain and offset errors.

[8] The offset error (E_O) is the absolute difference between the straight line which fits the actual curve and the straight line which fits the ideal curve. For best performance, force the offset calibration to -16. Set this prior to performing the gain calibration

[9] The full-scale error voltage or gain error (E_G) is the difference between the straight-line fitting the actual transfer curve after removing offset error, and the straight line which fits the ideal transfer curve.

[10] Input data is 1kHz sine wave, ADC conversion clock 24 MHz, Power Select = 3, Average setting = 4.

[11] Value of ADC_CFG[PUDLY] * 4 * ADCclk must be > tADCSTUP.

12.2.1 ADC input resistance (Please refer to the ADC Inputs Selection & ADC programming table in the UM)

Table 43. ADC input resistance

 $T_{amb} = -40\text{ °C to }+105\text{ °C}$

| | | | Min | Typ | Max | Unit |
|----------------|------------------|--|-----|-----|-----|------|
| R _I | input resistance | | | | | |

Table 43. ADC input resistance...continued

 $T_{amb} = -40\text{ °C to }+105\text{ °C}$

| | | Min | Typ | Max | Unit |
|--|-------------------------|-----|-----|-----|------|
| | Fast Input Channels | | | | |
| | PIO0_16/PIO0_23 | - | 1 | 2 | kΩ |
| | PIO0_11/PIO0_10 | - | 1 | 2 | kΩ |
| | PIO0_12/PIO0_15 | - | 1 | 2 | kΩ |
| | PIO1_0/PIO0_31 | - | 1 | 2 | kΩ |
| | Standard Input Channels | | | | |
| | PIO1_9/PIO1_8 | - | 1.4 | 3.6 | kΩ |

12.3 Temperature sensor

The ADC has a dedicated input channel for an on-chip temperate sensor that is mapped on channel 26.

Table 44. Temperature sensor static and dynamic characteristics

 $VBAT_PMU = VBAT_DCDC = VDD = 3.0\text{ V}$

| Symbol | Parameter | Conditions | Min | Typ | Max | Unit |
|-------------|-----------------------------|---|-------|-----|-----|------|
| DT_{sen} | sensor temperature accuracy | $T_{amb} = -40\text{ °C to }+105\text{ °C}$ | [1] - | - | 4 | °C |
| $t_{s(pu)}$ | power-up settling time | | [2] - | 5 | - | μs |

[1] Absolute temperature accuracy. Based on characterization, not tested in production.

[2] Typical values are derived from nominal simulation

12.4 Comparator

Table 45. Comparator characteristics

 $T_{amb} = -40\text{ °C to }+105\text{ °C unless noted otherwise; }VBAT_PMU = 1.8\text{ V to }3.6\text{ V.}$

| Symbol | Parameter | Conditions | Min | Typ ^[1] | Max | Unit |
|--------------------------------|---------------------------|---|-----|--------------------|-------------|------|
| Static characteristics | | | | | | |
| I_{DD} | supply current | Low Power Mode | - | 2.5 | - | μA |
| | | Fast Mode | - | 5 | - | μA |
| V_{IC} | common-mode input voltage | Propagation delay; $V_{cm_min} = 0.1\text{ V to }VBAT_PMU - 0.1\text{ V}$ | 0 | - | $VBAT_PMU$ | V |
| V_{offset} | offset voltage | Common mode input voltage < $VBAT_PMU - 0.2\text{ V}$ | 0 | - | 10 | mV |
| V_{offset} | offset voltage | Common mode input voltage (Range: $VBAT_PMU - 0.2\text{ V: }VBAT_PMU - 0.1\text{ V}$) | 0 | - | 20 | mV |
| Dynamic characteristics | | | | | | |
| $t_{startup}$ | start-up time | nominal process; $VBAT_PMU = 3.3\text{ V}$; $T_{amb} = 25\text{ °C}$, Max overdrive with reference at mid-supply | - | 3.3 | - | μs |

Table 45. Comparator characteristics...continued

 $T_{amb} = -40\text{ }^{\circ}\text{C}$ to $+105\text{ }^{\circ}\text{C}$ unless noted otherwise; $V_{BAT_PMU} = 1.8\text{ V}$ to 3.6 V .

| Symbol | Parameter | Conditions | Min | Typ ^[1] | Max | Unit |
|--|---|--|------|--------------------|------|------------------|
| t_{delay} | propagation delay time Low Power Mode negative input = $V_{BAT_PMU}/2$ | $V_{\text{overdrive}} = 10\text{ mV}$ | - | 1150 | 6000 | ns |
| | | $V_{\text{overdrive}} = 50\text{ mV}$ | - | 3100 | - | ns |
| | | $V_{\text{overdrive}} = \text{max}^{[2]}$ | - | 900 | 3000 | ns |
| | propagation delay time Low Power Mode negative input = $V_{BAT_PMU} - 0.1\text{ V}$ | $V_{\text{overdrive}} = 10\text{ mV}$ | - | 6000 | - | ns |
| | | $V_{\text{overdrive}} = 50\text{ mV}$ | - | 6000 | - | ns |
| | | $V_{\text{overdrive}} = \text{max}^{[2]}$ | - | 4400 | - | ns |
| | propagation delay time Low Power Mode negative input = 0.1 V | $V_{\text{overdrive}} = 10\text{ mV}$ | - | 2400 | - | ns |
| | | $V_{\text{overdrive}} = 50\text{ mV}$ | - | 2300 | - | ns |
| | | $V_{\text{overdrive}} = \text{max}$ | - | 50 | 2000 | ns |
| | propagation delay time High Speed Mode negative input = $V_{BAT_PMU}/2$ | $V_{\text{overdrive}} = 10\text{ mV}$ | - | 800 | 2000 | ns |
| | | $V_{\text{overdrive}} = 50\text{ mV}$ | - | 520 | - | ns |
| | | $V_{\text{overdrive}} = \text{max}^{[2]}$ | - | 210 | 300 | ns |
| propagation delay time High Speed Mode negative input = $V_{BAT_PMU} - 0.1\text{ V}$ | $V_{\text{overdrive}} = 10\text{ mV}$ | - | 1600 | - | ns | |
| | $V_{\text{overdrive}} = 50\text{ mV}$ | - | 1150 | - | ns | |
| | $V_{\text{overdrive}} = \text{max}^{[2]}$ | - | 790 | - | ns | |
| propagation delay time High Speed Mode negative input = 0.1 V | $V_{\text{overdrive}} = 10\text{ mV}$ | - | 1400 | - | ns | |
| | $V_{\text{overdrive}} = 50\text{ mV}$ | - | 405 | - | ns | |
| | $V_{\text{overdrive}} = \text{max}^{[2]}$ | - | 40 | 100 | ns | |
| $V_{\text{hys}}^{[3]}$ | hysteresis voltage ($V_{\text{HYST_P}} - V_{\text{HYST_N}}$) | Common Mode Input Voltages in [200 mV: $V_{\text{bat}} - 200\text{mV}$] range (See $V_{\text{in_N}}$ in Figure 25) | - | 100 | 200 | mV |
| R_{ladder} | ladder resistance | Resistive ladder, Divider ratio programmed with 5-bit control word. Entry point is either PIO1_19 or internal V_{BAT_PMU} | - | 1.27 | - | $\text{M}\Omega$ |

[1] Characterized on typical samples, not tested in production; $T_{amb} = 25\text{ }^{\circ}\text{C}$ [2] Max is the difference between V_{BAT_PMU} and negative voltage level.

[3] On device revision 0A, the hysteresis on the comparator cannot be enabled

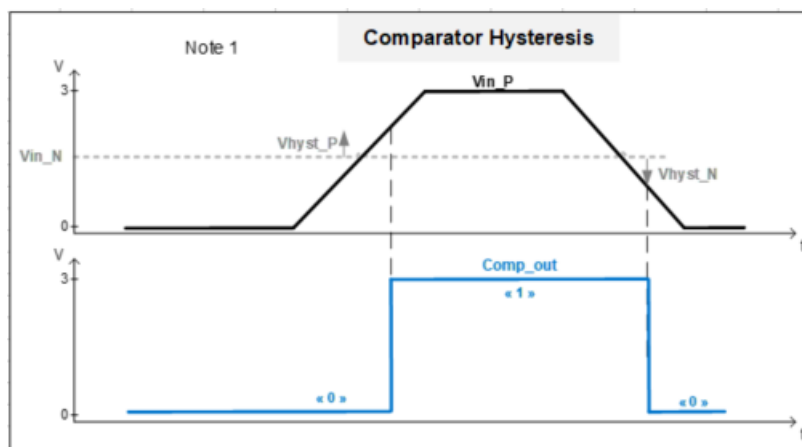

Figure 25. Comparator Hysteresis

13 Application information

13.1 Start-up behavior

Figure 26 shows the start-up timing after reset. The FRO oscillator provides the default clock at Reset and provides a clean system clock shortly after the supply pins reach operating voltage.

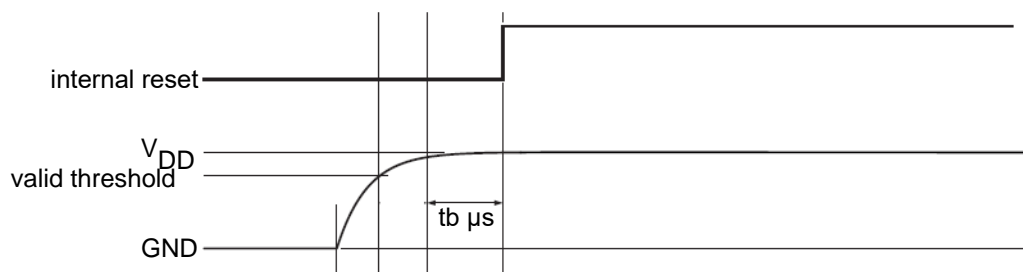

Figure 26. Start-up timing

Table 46. Typical start-up timing parameters

| Symbol | Parameter | Conditions |
|--------|----------------------------|--------------------------------------|
| t_b | Internal reset de-asserted | 540 μs typical, 1 ms worst case |

13.2 I/O power consumption

I/O pins are contributing to the overall dynamic and static power consumption of the part. If pins are configured as digital inputs, a static current can flow depending on the voltage level at the pin and the setting of the internal pull-up and pull-down resistors. This current can be calculated using the parameters R_{pu} and R_{pd} given in Table 24 for a given input voltage V_I . For pins set to output, the current drive strength is given by parameters I_{OH} and I_{OL} in Table 24, but for calculating the total static current, you also need to consider any external loads connected to the pin.

I/O pins also contribute to the dynamic power consumption when the pins are switching because the V_{DD} supply provides the current to charge and discharge all internal and external capacitive loads connected to the pin in addition to powering the I/O circuitry.

The contribution from the I/O switching current I_{sw} can be calculated as follows for any given switching frequency f_{sw} if the external capacitive load (C_{ext}) is known (see [Table 24](#) for the internal I/O capacitance):

$$I_{sw} = V_{DD} \times f_{sw} \times (C_{io} + C_{ext})$$

13.3 Crystal oscillator

The crystal oscillator has embedded capacitor bank where it can be used as an integrated load capacitor for the crystal oscillators. The capacitor banks on each crystal pin can tune the frequency for crystals with a Capacitive Load (CL) between 6 to 10pF (IEC equivalent). Simple APIs to configure the Capacitor Banks based on the crystal Capacitive Load (CL) and measured PCB parasitic capacitances on XIN and XOUT pins. In the crystal oscillator circuit, only the crystal (XTAL) needs to be connected with the option to connect capacitances CX1 and CX2 on XTAL32M_P and XTAL32M_N pins. Depending upon the computation of the required Capacitive Load, there is no need to add some capacitance on PCB if computation is less than 20 pF (10 pF equivalent IEC), and if computation is greater than 20 pF (10 pF equivalent IEC), then additional capacitance is on PCB required. See [Figure 27](#) and refer to the "Cap Bank API" chapter in the user manual. In bypass mode, an external clock (maximum frequency of up to 25 MHz) can also be connected to XTAL32M_P if XTAL32M_N is left open. External [0 – VH] square signal can be applied on the XTAL32M_P pin from 0 V to 850 mV.

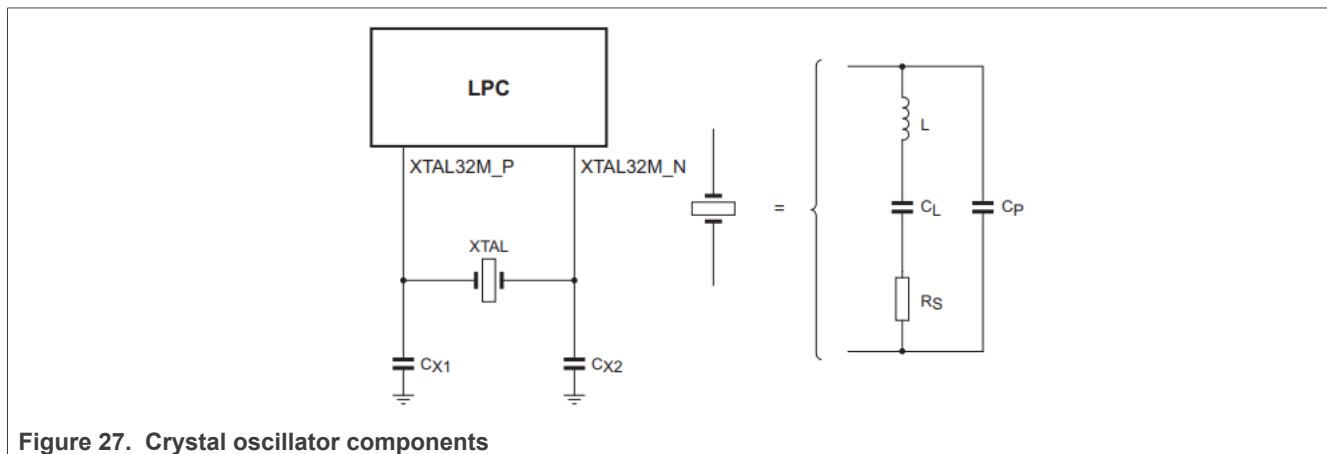

Figure 27. Crystal oscillator components

For best results, it is very critical to select a matching crystal for the on-chip oscillator. Load capacitance (CL), series resistance (RS), and drive level (DL) are important parameters to consider while choosing the crystal.

13.3.1 Crystal Printed Circuit Board (PCB) design guidelines

- Connect the crystal and external load capacitors on the PCB as close as possible to the oscillator input and output pins of the chip.
- The length of traces in the oscillation circuit should be as short as possible and must not cross other signal lines.
- Ensure that the load capacitors have a common ground plane.
- Loops must be made as small as possible to minimize the noise coupled in through the PCB and to keep the parasitics as small as possible.
- Lay out the ground (GND) pattern under crystal unit.
- Do not lay out other signal lines under crystal unit for multi-layered PCB.

13.4 RTC oscillator

The crystal oscillator has embedded capacitor bank where it can be used as an integrated load capacitor for the crystal oscillators. The capacitor banks on each crystal pin can tune the frequency for crystals with a Capacitive Load (CL) between 6 to 10pF (IEC equivalent).

Simple APIs to configure the Capacitor Banks based on the crystal Capacitive Load (CL) and measured PCB parasitic capacitances on XIN and XOUT pins.

In the crystal oscillator circuit, only the crystal (XTAL) needs to be connected with the option to connect capacitances CX1 and CX2 on XTAL32K_P and XTAL32K_N pins. Depending upon the computation of the required Capacitance Load, there is no need to add some capacitance on PCB if computation is less than 20 pF (10 pF equivalent IEC), and if computation is greater than 20 pF (10 pF equivalent IEC), then additional capacitance is on PCB required. See [Figure 23](#) and refer to the "Cap Bank API" chapter in the user manual.

In bypass mode, an external clock (maximum frequency of up to 100 kHz) can also be connected to XTAL32K_P if XTAL32K_N is left open. External [0 – VH] square signal can be applied on the XTAL32K_P pin with 1.1 V +/-10%

A external signal below 1.0 V or above 1.2 V cannot be applied

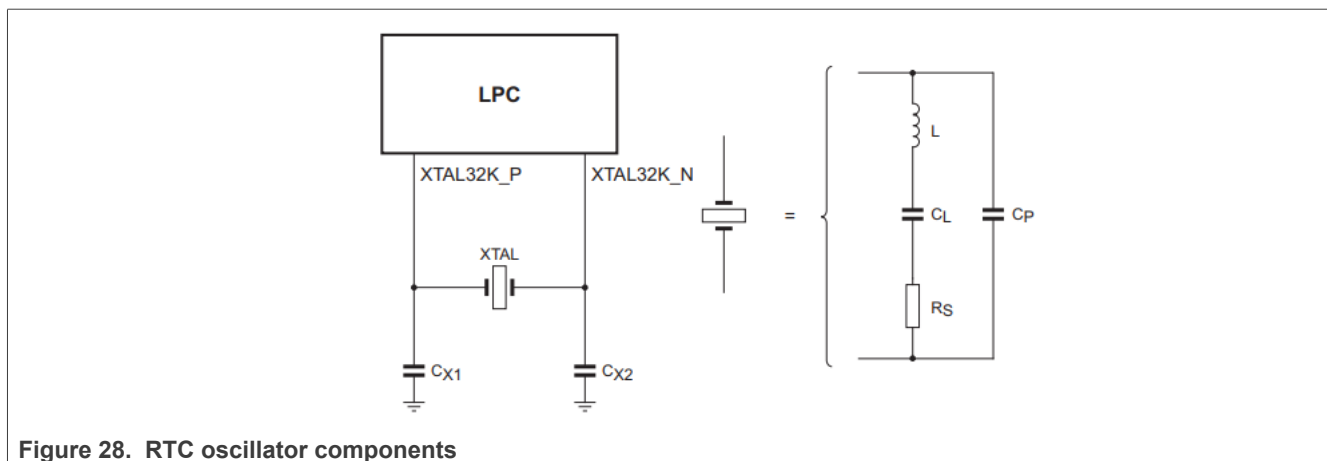

Figure 28. RTC oscillator components

For best results, it is very critical to select a matching crystal for the on-chip oscillator. Load capacitance (CL), series resistance (RS), and drive level (DL) are important parameters to consider while choosing the crystal.

13.4.1 RTC Printed Circuit Board (PCB) design guidelines

- Connect the crystal and external load capacitors on the PCB as close as possible to the oscillator input and output pins of the chip.
- The length of traces in the oscillation circuit should be as short as possible and must not cross other signal lines.
- Ensure that the load capacitors have a common ground plane.
- Loops must be made as small as possible to minimize the noise coupled in through the PCB and to keep the parasitics as small as possible.
- Lay out the ground (GND) pattern under crystal unit.
- Do not lay out other signal lines under crystal unit for multi-layered PCB.

13.5 Suggested USB Full-speed interface solutions

The USB device can be connected to the USB as self-powered device (see [Figure 29](#)"USB interface on a self-powered device where USB_VBUS = 5 V") or bus-powered device (see [Figure 30](#)).

The USB_VBUS pin is 5 V tolerant only when VDD is applied and at operating voltage level. Therefore, if the USB_VBUS function is connected to the USB connector and the device is self-powered, the USB_VBUS pin must be protected for situations when

VDD = 0 V.

If VDD is always at operating level while VBUS = 5 V, the USB_VBUS pin can be connected directly to the VBUS pin on the USB connector.

For such USB applications, the internal pull-down on the GPIO/VBUS pad must be enabled on pins P0_22 or P1_11 when attaching/de-attaching in the USB application. Enable the internal pull-downs with user software. For USB ISP mode, the internal resistor pull-down is not enabled on the P0_22 pin where the VBUS pin can be floating. USB enumeration may still occur when VBUS is not connected.

For systems where VDD can be 0 V and VBUS is directly applied to the VBUS pin, precautions must be taken to reduce the voltage to below 3.6 V, which is the maximum allowable voltage on the USB_VBUS pin in this case.

One method is to use a voltage divider to connect the USB_VBUS pin to the VBUS on the USB connector. The voltage divider ratio should be such that the USB_VBUS pin is greater than 0.7 VDD to indicate a logic HIGH while below the 3.6 V allowable maximum voltage.

For the following operating conditions:

VBUS_{max} = 5.25 V

VDD = 3.6 V

The voltage divider should provide a reduction of 3.6 V/5.25 V or ~0.686 V.

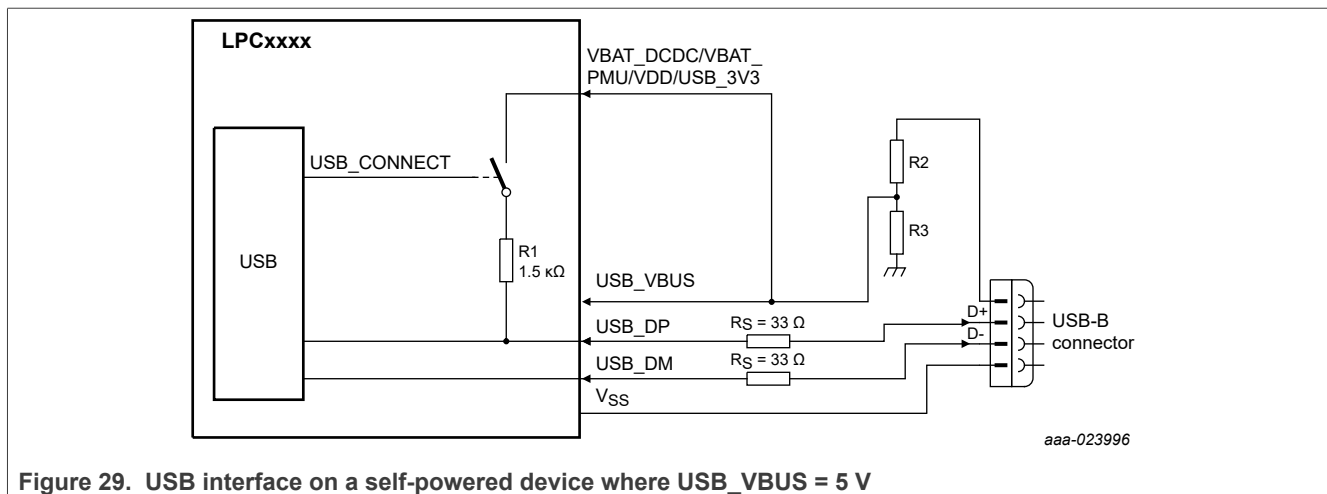

Figure 29. USB interface on a self-powered device where USB_VBUS = 5 V

The internal pull-up (1.5 kΩ) can be enabled by setting the DCON bit in the DEVCMDSTAT register to prevent the USB from timing out when there is a significant delay between power-up and handling USB traffic. External circuitry is not required.

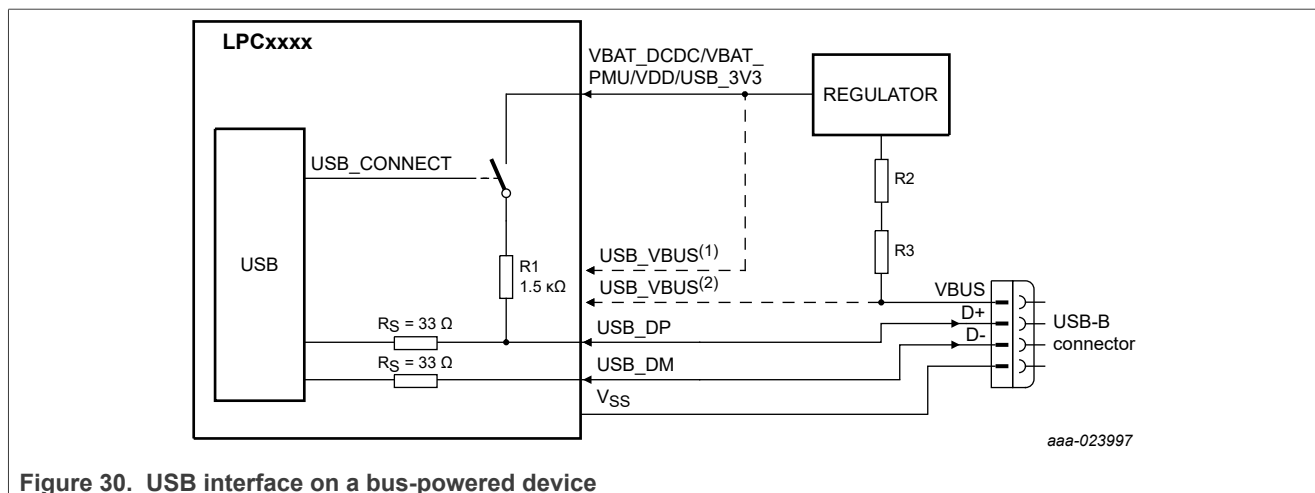

Figure 30. USB interface on a bus-powered device

Two options exist for connecting VBUS to the USB_VBUS pin:

- Connect the regulator output to USB_VBUS. In this case, the USB_VBUS signal is HIGH whenever the part is powered.
- Connect the VBUS signal directly from the connector to the USB_VBUS pin. In this case, 5 V are applied to the USB_VBUS pin while the regulator is ramping up to supply VDD. Since the USB_VBUS pin is only 5 V tolerant when VDD is at operating level, this connection can degrade the performance of the part over its lifetime. Simulation shows that lifetime is reduced to 15 years at $T_{amb} = 45\text{ °C}$ and 8 years at $T_{amb} = 55\text{ °C}$ assuming that $USB_VBUS = 5\text{ V}$ is applied continuously while $VDD = 0\text{ V}$.

13.6 USB1 High-speed VBUS threshold levels

The USB1 has the following characteristics for VBUS (see [Table 47](#)). The USB1_VBUS can tolerate an input voltage of 5.5 V.

Table 47. USB1 High-speed VBUS threshold levels

| Function | Min | Typ | Max | Unit |
|-----------------|-------|-----|------|------|
| Votg_sess_valid | 0.8 | - | 4.0 | V |
| VBUS_valid | 4.192 | - | 5.5 | V |
| Vadp_probe | 0.6 | - | 0.8 | V |
| Vadp_sense | 0.20 | - | 0.55 | V |

14 Package outline

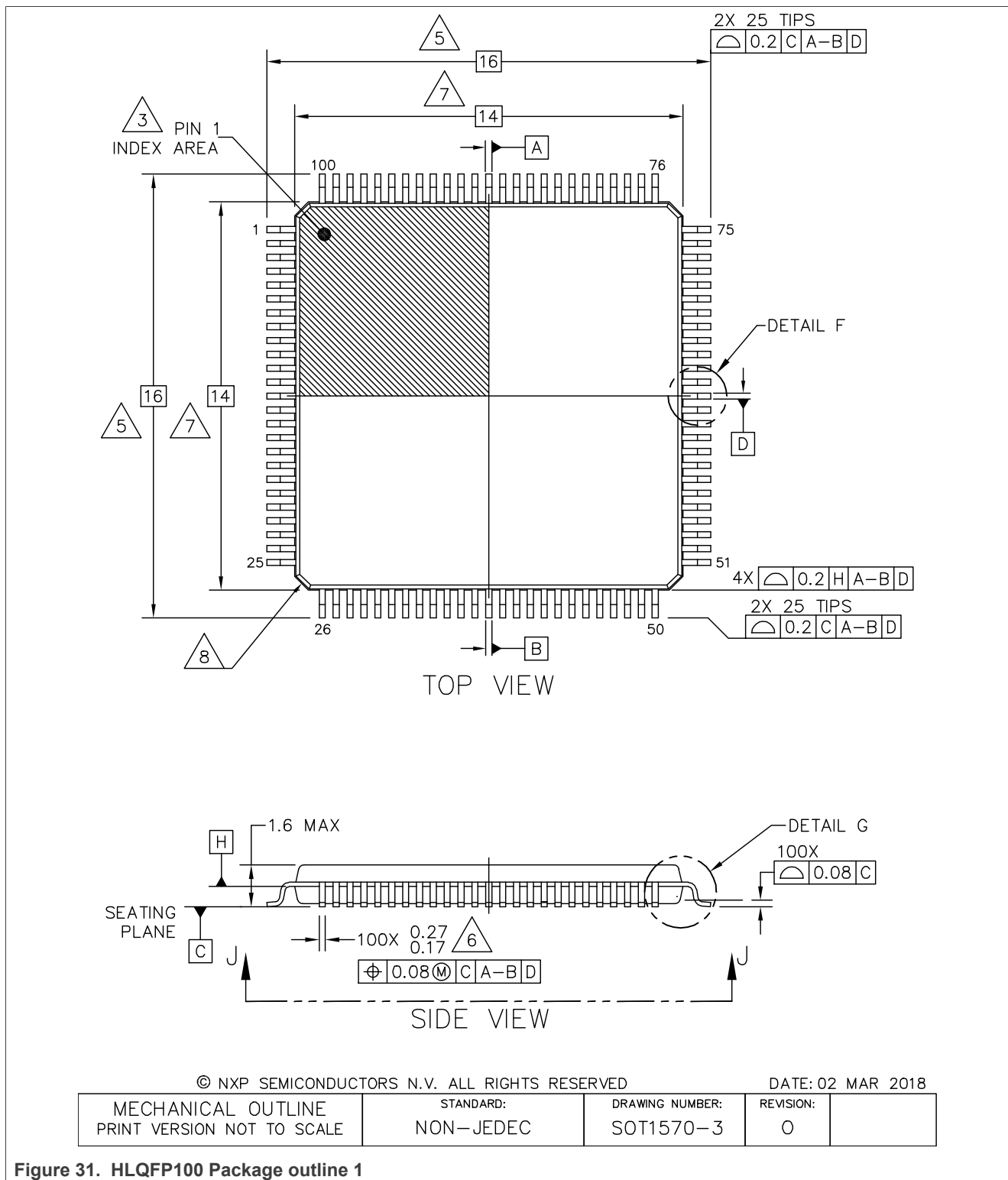

Figure 31. HLQFP100 Package outline 1

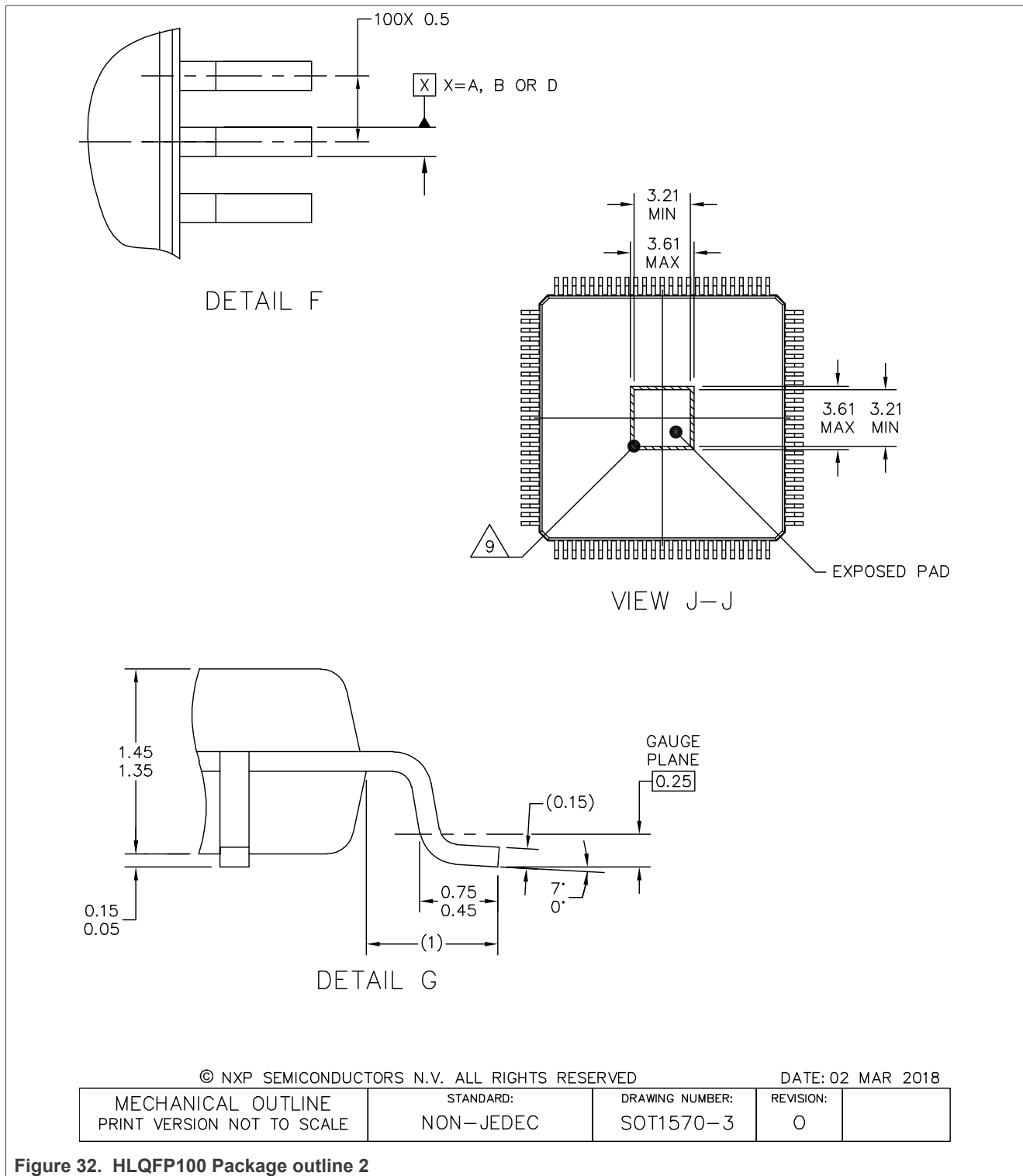

Figure 32. HLQFP100 Package outline 2

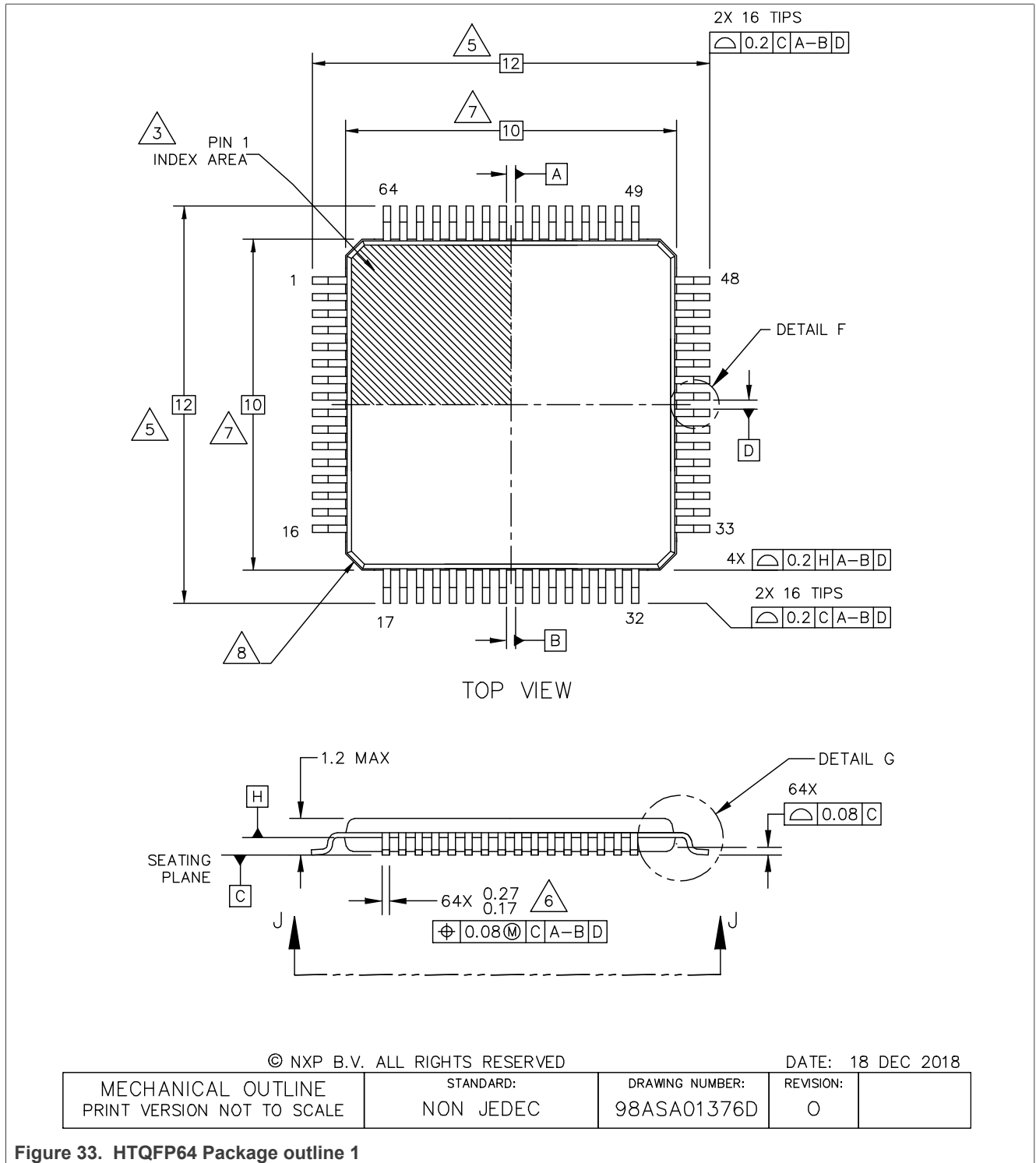
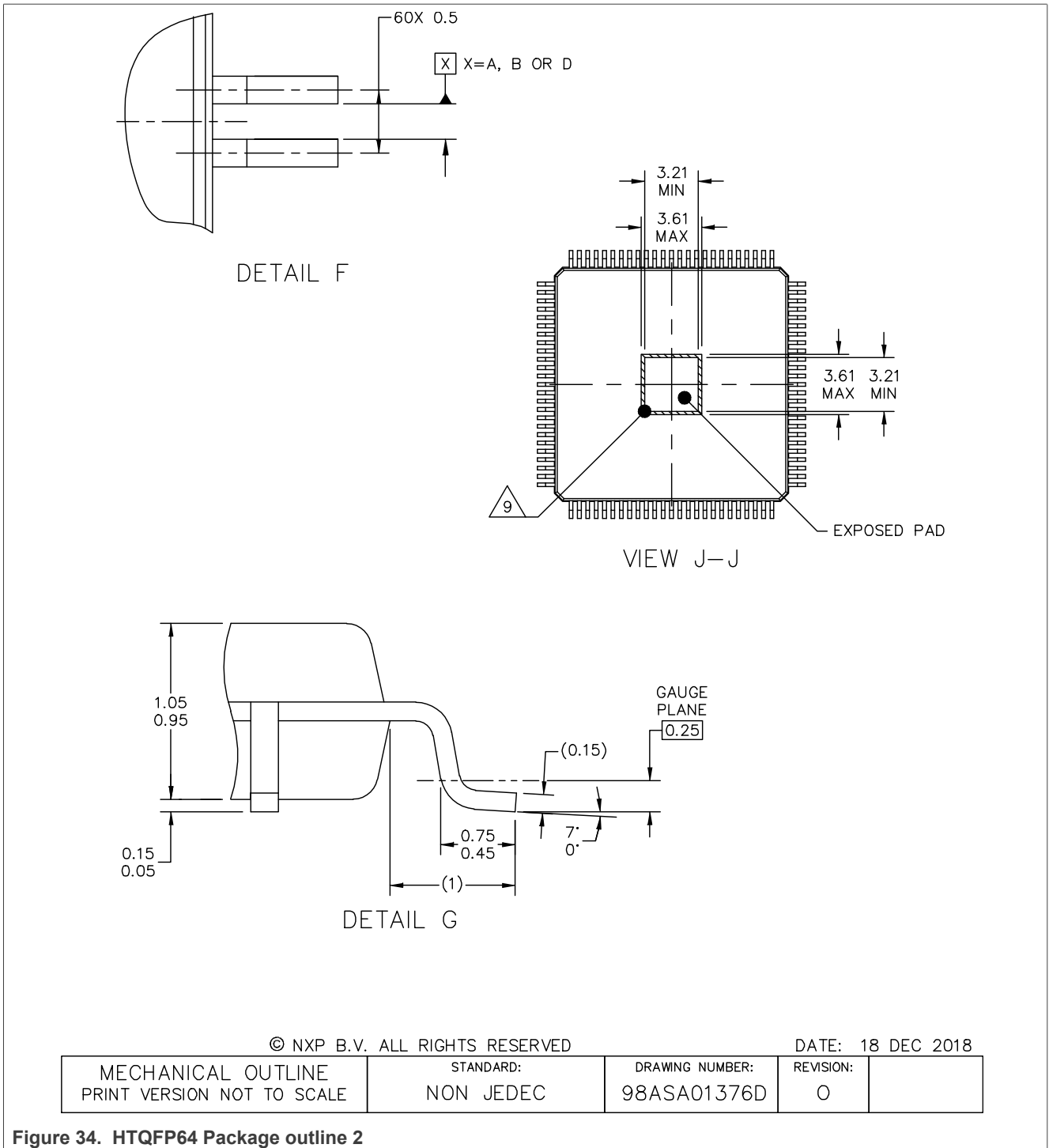

Figure 33. HTQFP64 Package outline 1



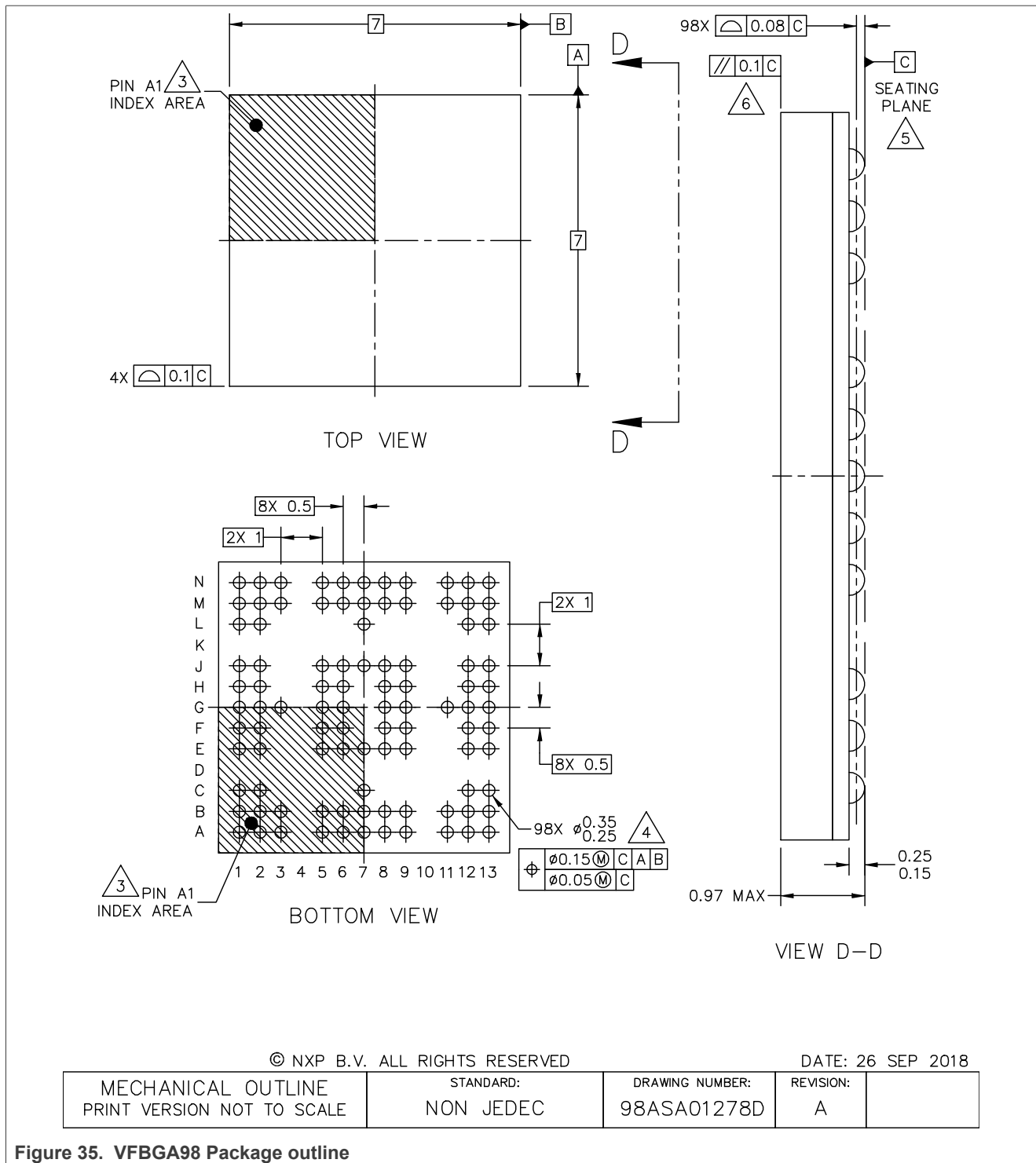

Figure 35. VFBGA98 Package outline

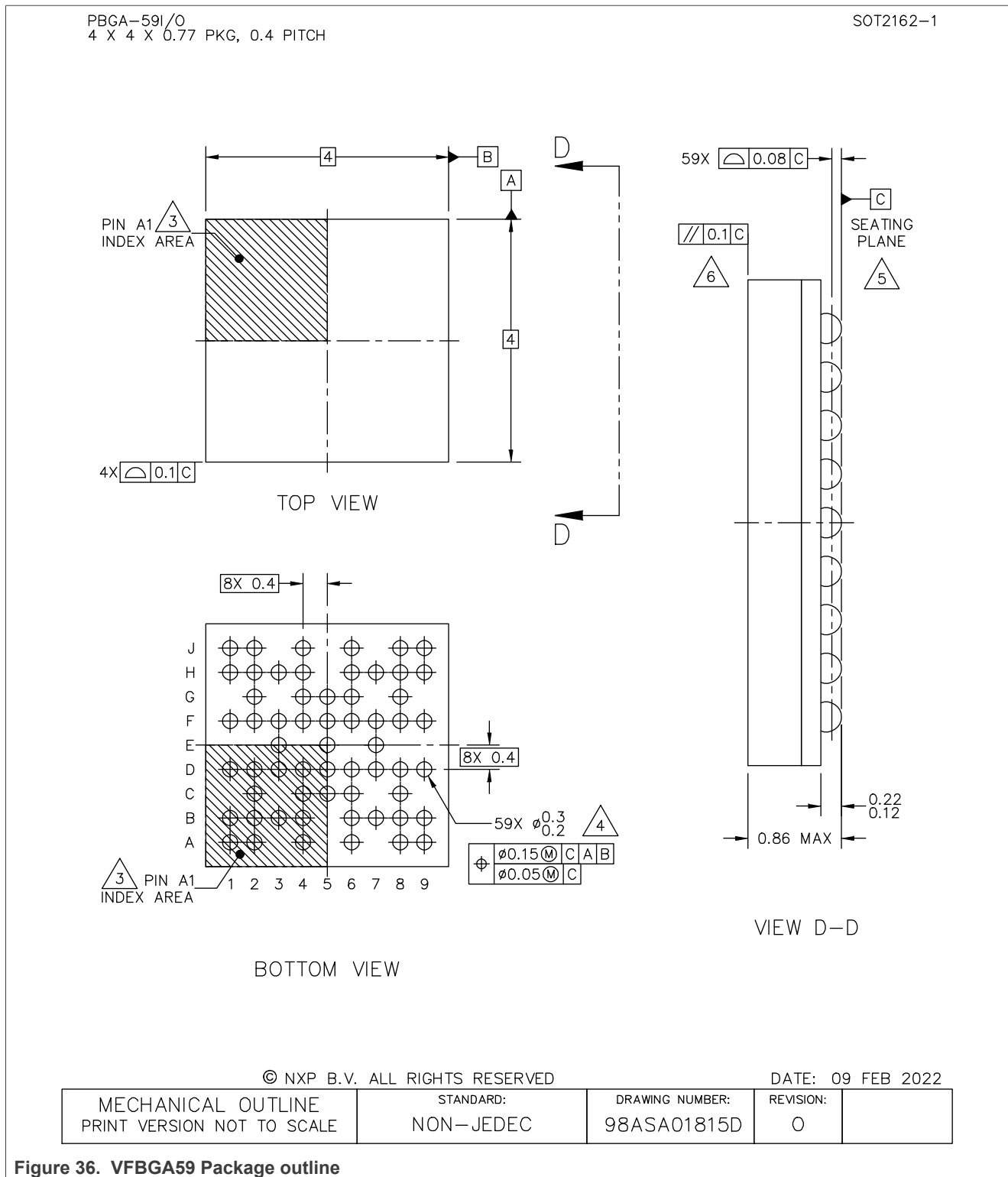
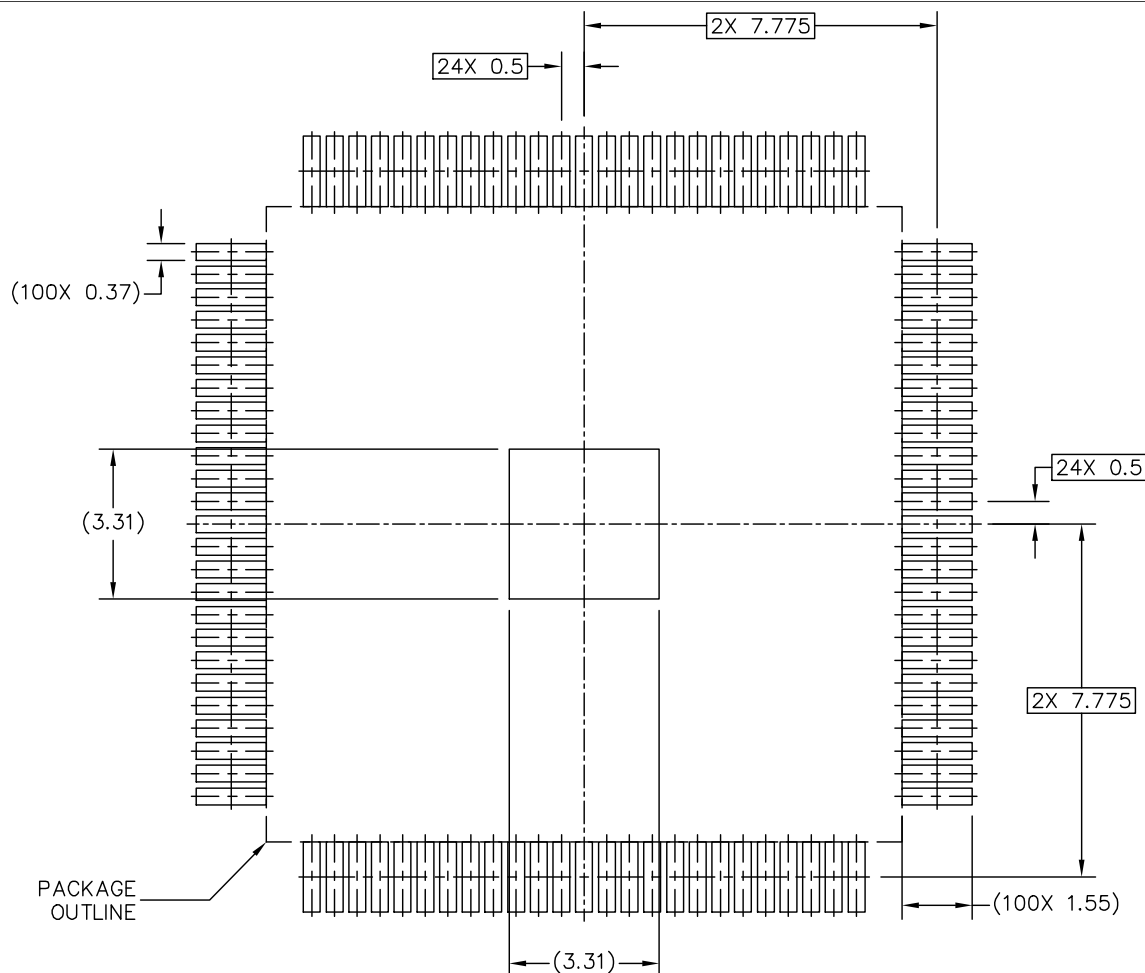

Figure 36. VFBGA59 Package outline

15 Soldering



PCB DESIGN GUIDELINES – SOLDER MASK OPENING PATTERN

THIS SHEET SERVES ONLY AS A GUIDELINE TO HELP DEVELOP A USER SPECIFIC SOLUTION. DEVELOPMENT EFFORT WILL STILL BE REQUIRED BY END USERS TO OPTIMIZE PCB MOUNTING PROCESSES AND BOARD DESIGN IN ORDER TO MEET INDIVIDUAL/SPECIFIC REQUIREMENTS.

© NXP SEMICONDUCTORS N.V. ALL RIGHTS RESERVED

DATE: 02 MAR 2018

| | | | | |
|--|------------------------|------------------------------|----------------|--|
| MECHANICAL OUTLINE PRINT VERSION NOT TO SCALE | STANDARD: NON-JEDEC | DRAWING NUMBER: SOT1570-3 | REVISION: 0 | |
|--|------------------------|------------------------------|----------------|--|

Figure 37. HLQFP100 Soldering footprint part 1

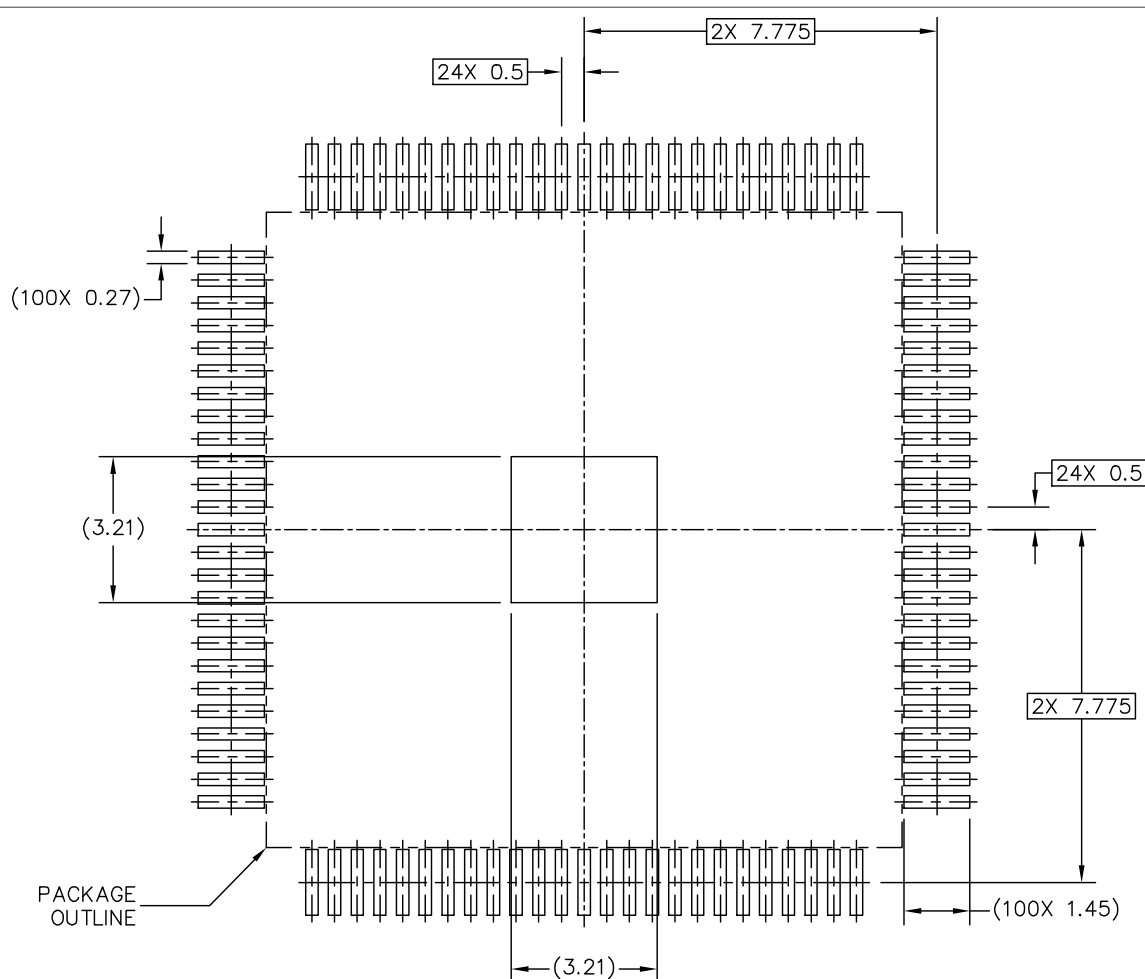

PCB DESIGN GUIDELINES – I/O PADS AND SOLDERABLE AREA

THIS SHEET SERVES ONLY AS A GUIDELINE TO HELP DEVELOP A USER SPECIFIC SOLUTION. DEVELOPMENT EFFORT WILL STILL BE REQUIRED BY END USERS TO OPTIMIZE PCB MOUNTING PROCESSES AND BOARD DESIGN IN ORDER TO MEET INDIVIDUAL/SPECIFIC REQUIREMENTS.

© NXP SEMICONDUCTORS N.V. ALL RIGHTS RESERVED

DATE: 02 MAR 2018

| | | | | |
|--|------------------------|------------------------------|----------------|--|
| MECHANICAL OUTLINE PRINT VERSION NOT TO SCALE | STANDARD: NON-JEDEC | DRAWING NUMBER: SOT1570-3 | REVISION: 0 | |
|--|------------------------|------------------------------|----------------|--|

Figure 38. HLQFP100 Soldering footprint part 2

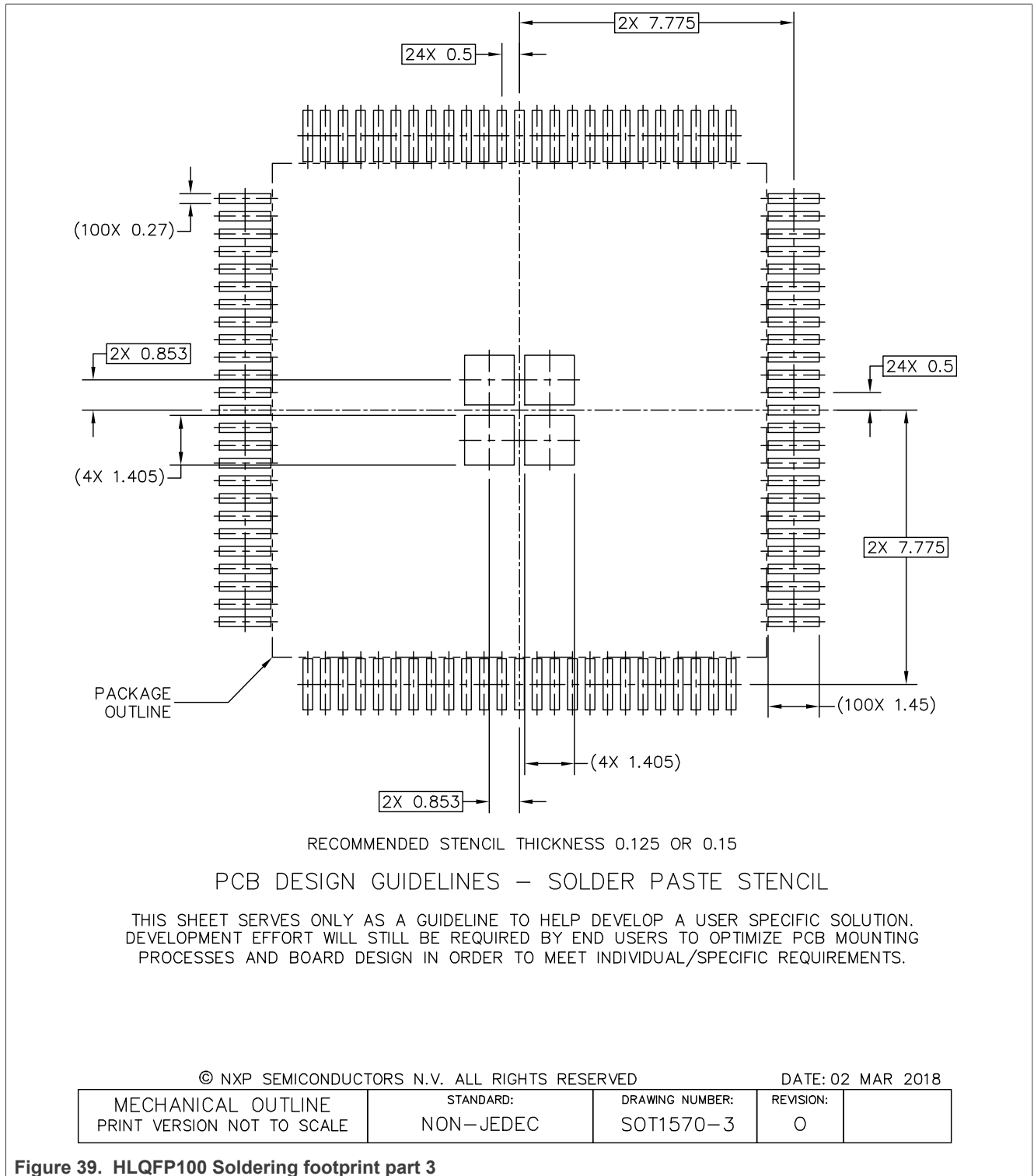

Figure 39. HLQFP100 Soldering footprint part 3

NOTES:

1. DIMENSIONS ARE IN MILLIMETERS.
2. DIMENSIONING AND TOLERANCING PER ASME Y14.5M-1994.
3. PIN 1 FEATURE SHAPE, SIZE AND LOCATION MAY VARY.
4. DATUMS A, B AND D TO BE DETERMINED AT DATUM PLANE H.
5. DIMENSION TO BE DETERMINED AT SEATING PLANE C.
6. THIS DIMENSION DOES NOT INCLUDE DAMBAR PROTRUSION. ALLOWABLE DAMBAR PROTRUSION SHALL NOT CAUSE THE LEAD WIDTH TO EXCEED THE UPPER LIMIT BY MORE THAN 0.08MM AT MAXIMUM MATERIAL CONDITION. DAMBAR CANNOT BE LOCATED ON THE LOWER RADIUS OR THE FOOT. MINIMUM SPACE BETWEEN PROTRUSION AND ADJACENT LEAD SHALL NOT BE LESS THAN 0.07MM.
7. THIS DIMENSION DOES NOT INCLUDE MOLD PROTRUSION. ALLOWABLE PROTRUSION IS 0.25MM PER SIDE. THIS DIMENSION IS MAXIMUM PLASTIC BODY SIZE DIMENSION INCLUDING MOLD MISMATCH.
8. EXACT SHAPE OF EACH CORNER IS OPTIONAL.
9. HATCHED AREA TO BE KEEP OUT ZONE FOR PCB ROUTING.

© NXP SEMICONDUCTORS N.V. ALL RIGHTS RESERVED

DATE: 02 MAR 2018

| | | | | |
|--|------------------------|------------------------------|----------------|--|
| MECHANICAL OUTLINE PRINT VERSION NOT TO SCALE | STANDARD: NON-JEDEC | DRAWING NUMBER: SOT1570-3 | REVISION: 0 | |
|--|------------------------|------------------------------|----------------|--|

Figure 40. HLQFP100 Soldering footprint 4

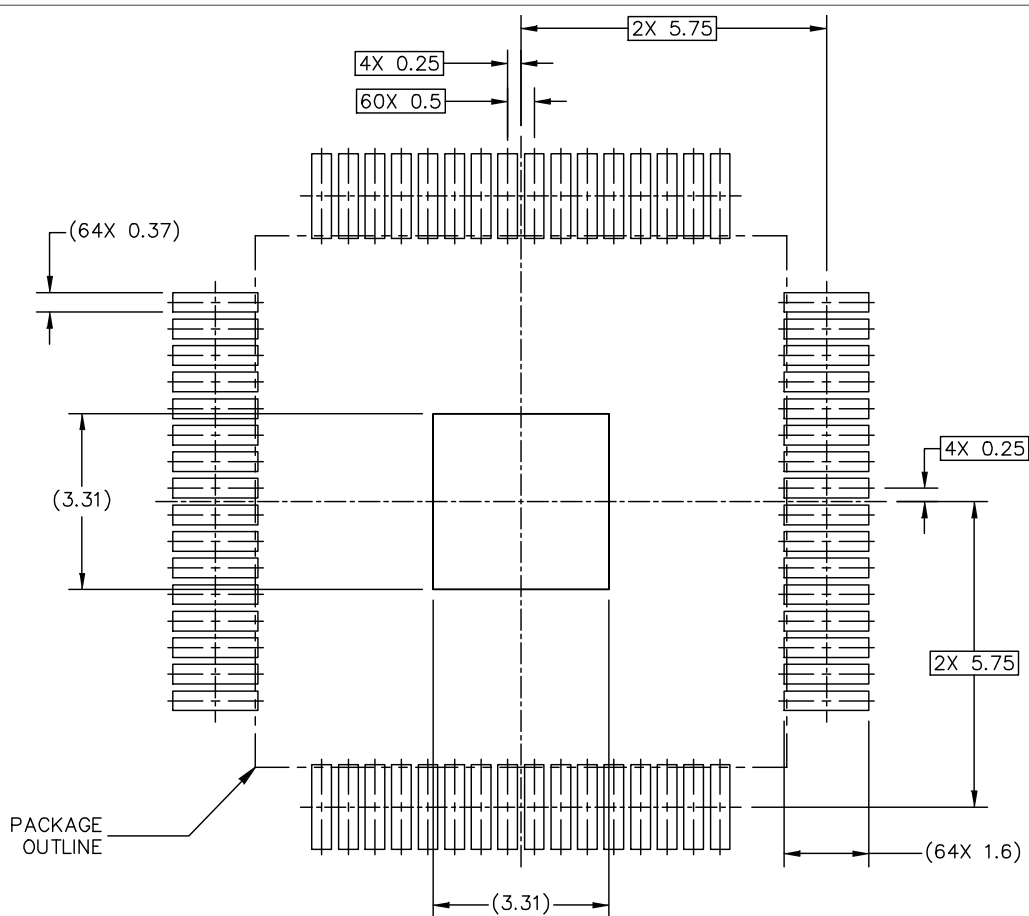

PCB DESIGN GUIDELINES – SOLDER MASK OPENING PATTERN

THIS SHEET SERVES ONLY AS A GUIDELINE TO HELP DEVELOP A USER SPECIFIC SOLUTION. DEVELOPMENT EFFORT WILL STILL BE REQUIRED BY END USERS TO OPTIMIZE PCB MOUNTING PROCESSES AND BOARD DESIGN IN ORDER TO MEET INDIVIDUAL/SPECIFIC REQUIREMENTS.

© NXP B.V. ALL RIGHTS RESERVED

DATE: 18 DEC 2018

| | | | |
|--|------------------------|--------------------------------|----------------|
| MECHANICAL OUTLINE PRINT VERSION NOT TO SCALE | STANDARD: NON JEDEC | DRAWING NUMBER: 98ASA01376D | REVISION: 0 |
|--|------------------------|--------------------------------|----------------|

Figure 41. HTQFP64 Soldering footprint part 1

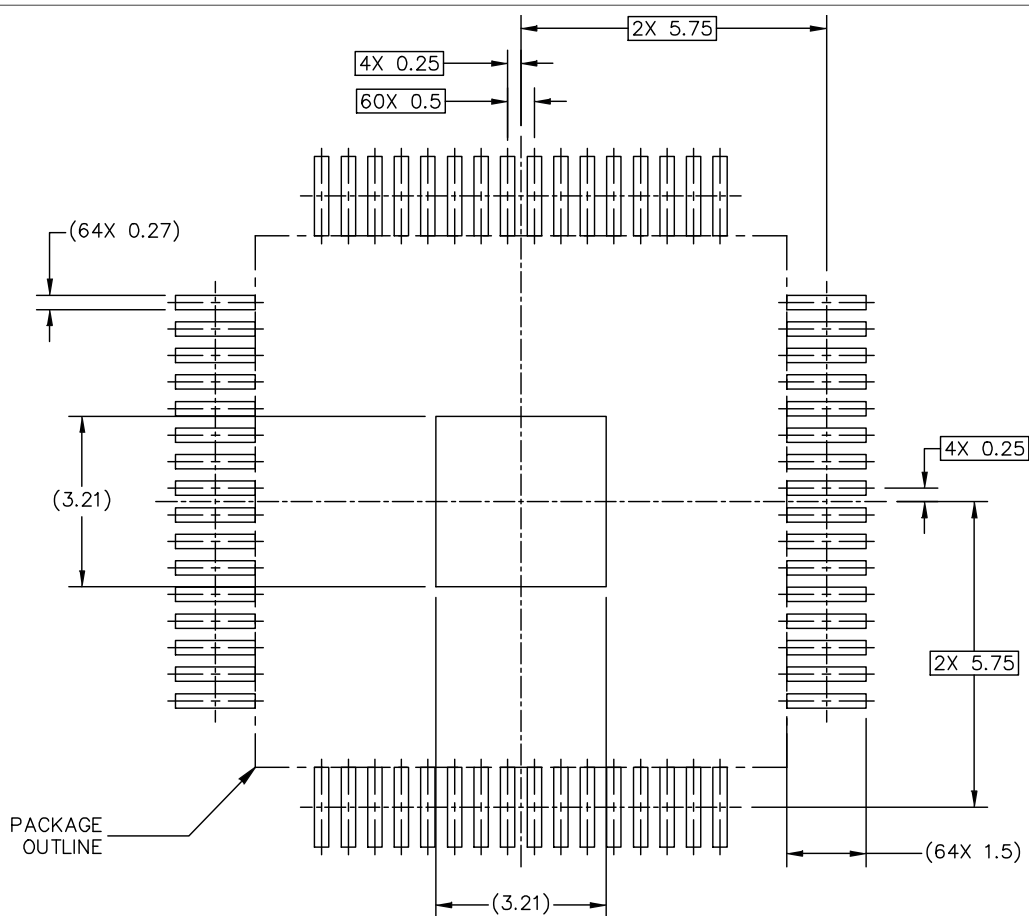

PCB DESIGN GUIDELINES – I/O PADS AND SOLDERABLE AREA

THIS SHEET SERVES ONLY AS A GUIDELINE TO HELP DEVELOP A USER SPECIFIC SOLUTION. DEVELOPMENT EFFORT WILL STILL BE REQUIRED BY END USERS TO OPTIMIZE PCB MOUNTING PROCESSES AND BOARD DESIGN IN ORDER TO MEET INDIVIDUAL/SPECIFIC REQUIREMENTS.

© NXP B.V. ALL RIGHTS RESERVED

DATE: 18 DEC 2018

| | | | |
|--|------------------------|--------------------------------|----------------|
| MECHANICAL OUTLINE PRINT VERSION NOT TO SCALE | STANDARD: NON JEDEC | DRAWING NUMBER: 98ASA01376D | REVISION: 0 |
|--|------------------------|--------------------------------|----------------|

Figure 42. HTQFP64 Soldering footprint part 2

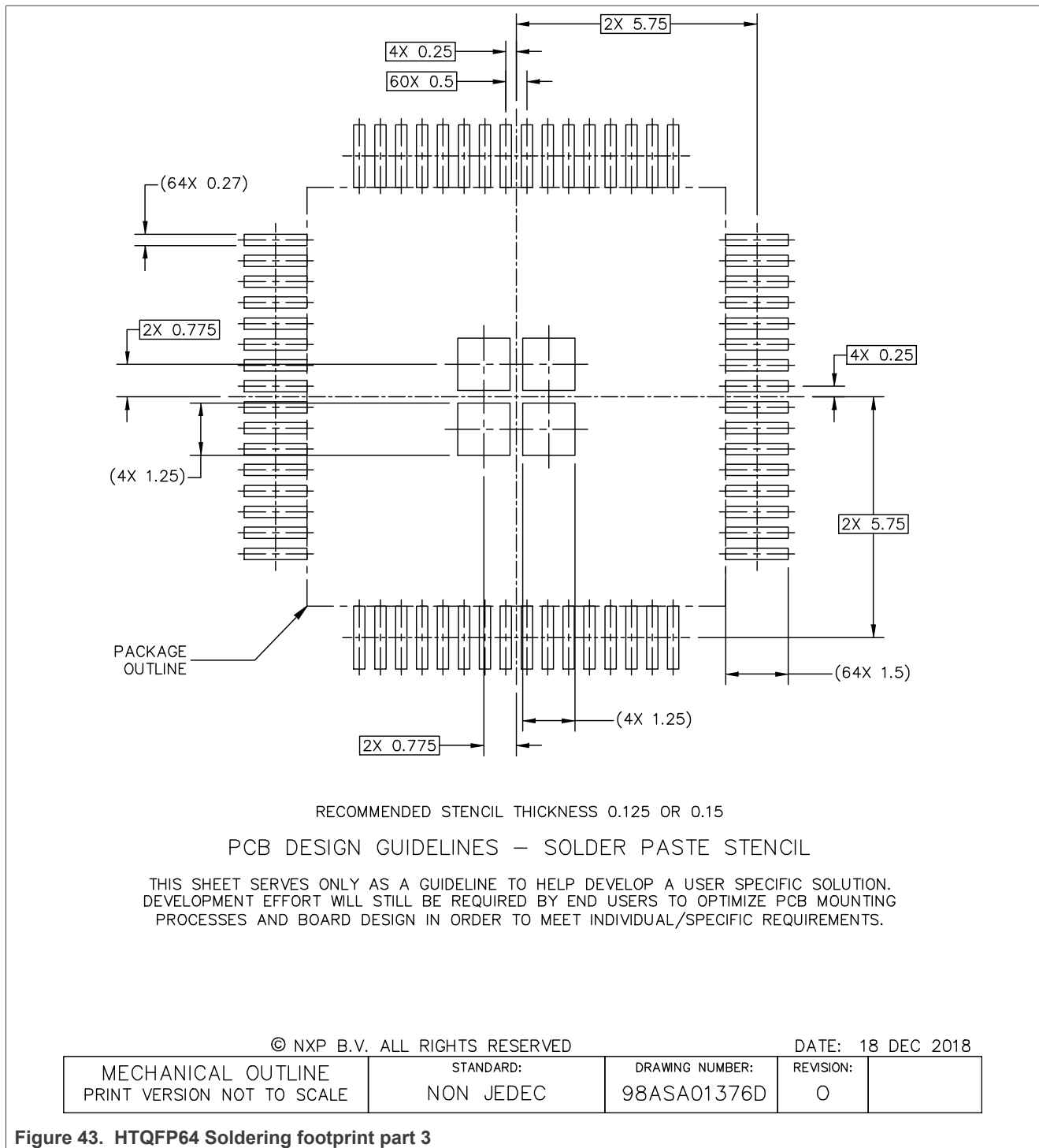

Figure 43. HTQFP64 Soldering footprint part 3

NOTES:

1. DIMENSIONS ARE IN MILLIMETERS.
2. DIMENSIONING AND TOLERANCING PER ASME Y14.5M-1994.
3. PIN 1 FEATURE SHAPE, SIZE AND LOCATION MAY VARY.
4. DATUMS A, B AND D TO BE DETERMINED AT DATUM PLANE H.
5. DIMENSION TO BE DETERMINED AT SEATING PLANE C.
6. THIS DIMENSION DOES NOT INCLUDE DAMBAR PROTRUSION. ALLOWABLE DAMBAR PROTRUSION SHALL NOT CAUSE THE LEAD WIDTH TO EXCEED THE UPPER LIMIT BY MORE THAN 0.08MM AT MAXIMUM MATERIAL CONDITION. DAMBAR CANNOT BE LOCATED ON THE LOWER RADIUS OR THE FOOT. MINIMUM SPACE BETWEEN PROTRUSION AND ADJACENT LEAD SHALL NOT BE LESS THAN 0.07MM.
7. THIS DIMENSION DOES NOT INCLUDE MOLD PROTRUSION. ALLOWABLE PROTRUSION IS 0.25MM PER SIDE. THIS DIMENSION IS MAXIMUM PLASTIC BODY SIZE DIMENSION INCLUDING MOLD MISMATCH.
8. EXACT SHAPE OF EACH CORNER IS OPTIONAL.
9. HATCHED AREA TO BE KEEP OUT ZONE FOR PCB ROUTING.

© NXP B.V. ALL RIGHTS RESERVED

DATE: 18 DEC 2018

| | | | | |
|--|------------------------|--------------------------------|----------------|--|
| MECHANICAL OUTLINE PRINT VERSION NOT TO SCALE | STANDARD: NON JEDEC | DRAWING NUMBER: 98ASA01376D | REVISION: 0 | |
|--|------------------------|--------------------------------|----------------|--|

Figure 44. HTQFP64 Soldering footprint 4

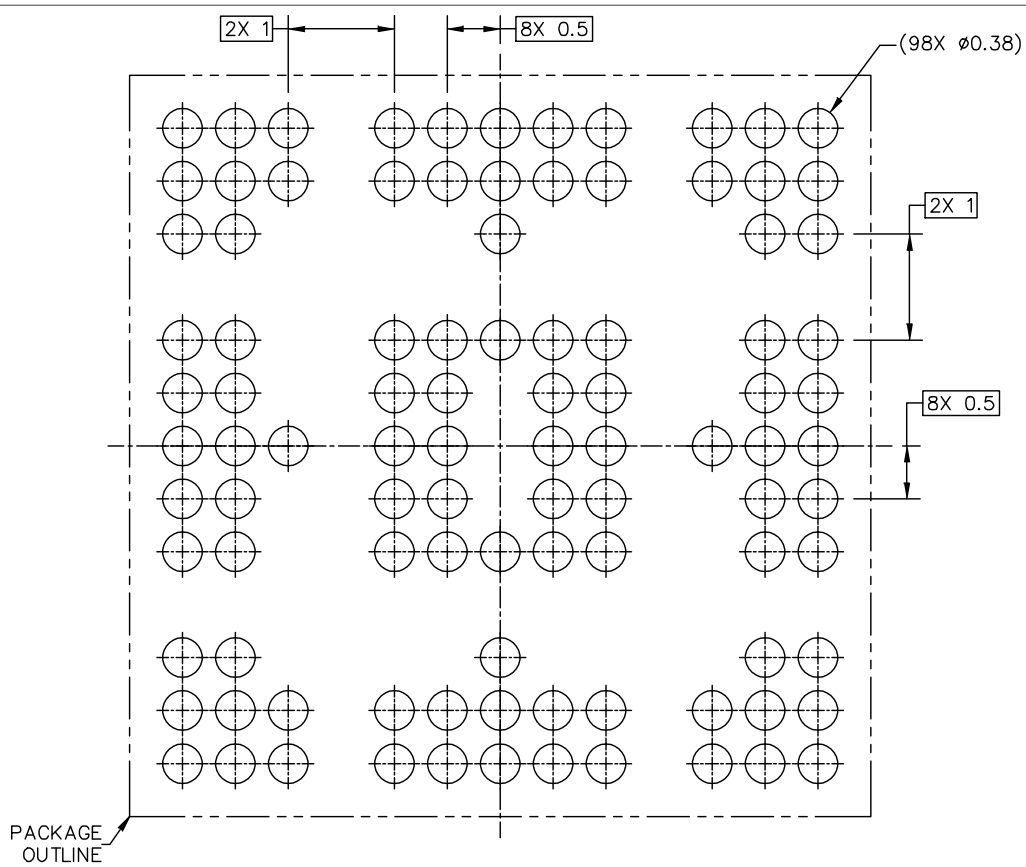

PCB DESIGN GUIDELINES – SOLDER MASK OPENING PATTERN

THIS SHEET SERVES ONLY AS A GUIDELINE TO HELP DEVELOP A USER SPECIFIC SOLUTION. DEVELOPMENT EFFORT WILL STILL BE REQUIRED BY END USERS TO OPTIMIZE PCB MOUNTING PROCESSES AND BOARD DESIGN IN ORDER TO MEET INDIVIDUAL/SPECIFIC REQUIREMENTS.

© NXP B.V. ALL RIGHTS RESERVED

DATE: 26 SEP 2018

| | | | | |
|--|------------------------|--------------------------------|----------------|--|
| MECHANICAL OUTLINE PRINT VERSION NOT TO SCALE | STANDARD: NON JEDEC | DRAWING NUMBER: 98ASA01278D | REVISION: A | |
|--|------------------------|--------------------------------|----------------|--|

Figure 45. VFBGA98 Soldering footprint part 1

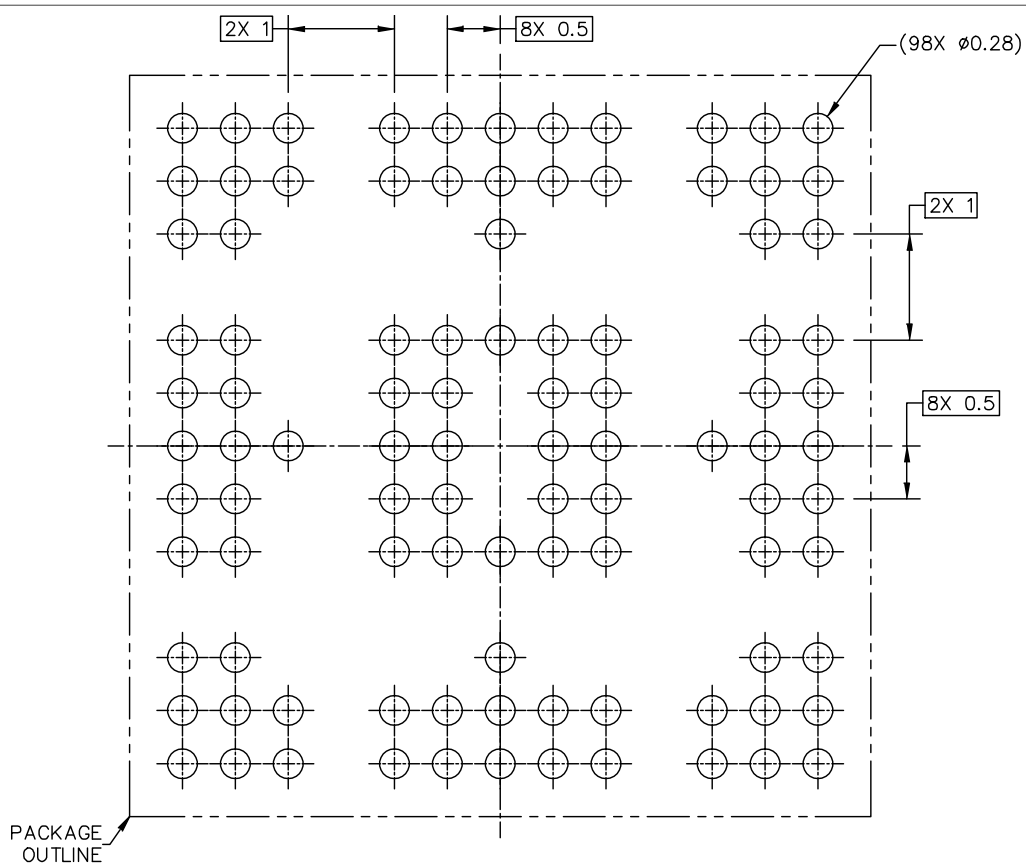

PCB DESIGN GUIDELINES – I/O PADS AND SOLDERABLE AREA

THIS SHEET SERVES ONLY AS A GUIDELINE TO HELP DEVELOP A USER SPECIFIC SOLUTION. DEVELOPMENT EFFORT WILL STILL BE REQUIRED BY END USERS TO OPTIMIZE PCB MOUNTING PROCESSES AND BOARD DESIGN IN ORDER TO MEET INDIVIDUAL/SPECIFIC REQUIREMENTS.

© NXP B.V. ALL RIGHTS RESERVED

DATE: 26 SEP 2018

| | | | | |
|--|------------------------|--------------------------------|----------------|--|
| MECHANICAL OUTLINE PRINT VERSION NOT TO SCALE | STANDARD: NON JEDEC | DRAWING NUMBER: 98ASA01278D | REVISION: A | |
|--|------------------------|--------------------------------|----------------|--|

Figure 46. VFBGA98 Soldering footprint part 2

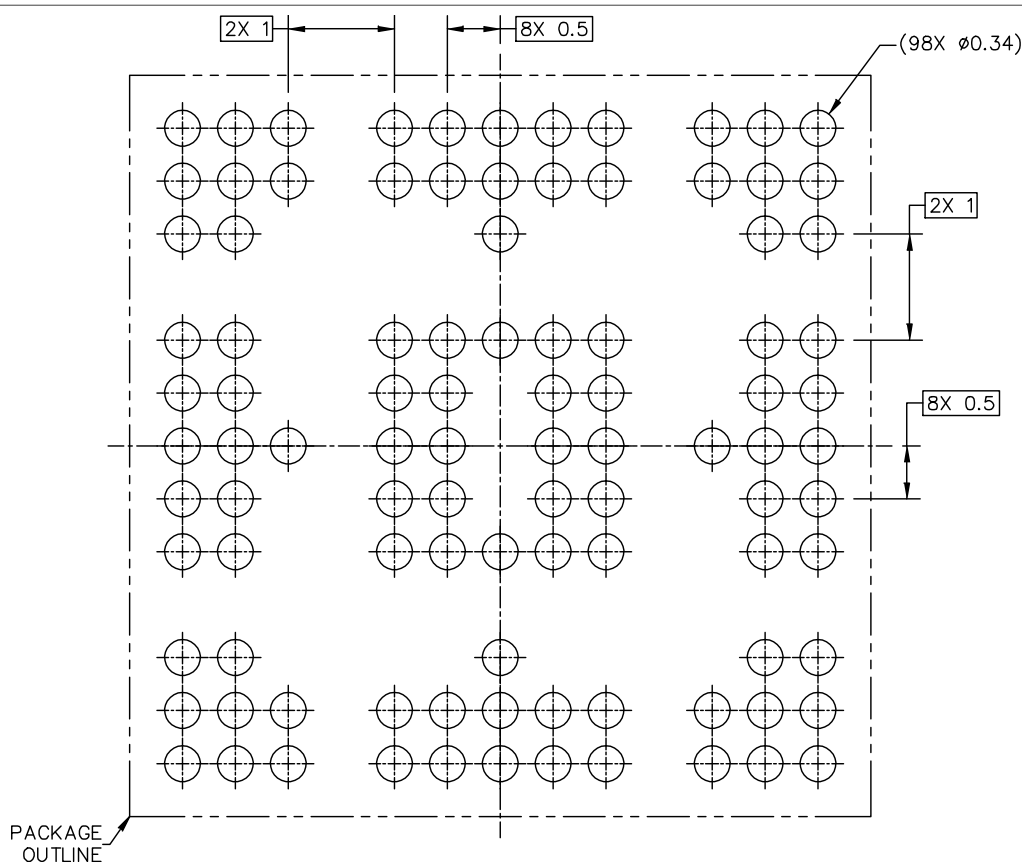

RECOMMENDED STENCIL THICKNESS 0.125
PCB DESIGN GUIDELINES – SOLDER PASTE STENCIL

THIS SHEET SERVES ONLY AS A GUIDELINE TO HELP DEVELOP A USER SPECIFIC SOLUTION. DEVELOPMENT EFFORT WILL STILL BE REQUIRED BY END USERS TO OPTIMIZE PCB MOUNTING PROCESSES AND BOARD DESIGN IN ORDER TO MEET INDIVIDUAL/SPECIFIC REQUIREMENTS.

© NXP B.V. ALL RIGHTS RESERVED

DATE: 26 SEP 2018

| | | | | |
|--|------------------------|--------------------------------|----------------|--|
| MECHANICAL OUTLINE PRINT VERSION NOT TO SCALE | STANDARD: NON JEDEC | DRAWING NUMBER: 98ASA01278D | REVISION: A | |
|--|------------------------|--------------------------------|----------------|--|

Figure 47. VFBGA98 Soldering footprint part 3

NOTES:

1. ALL DIMENSIONS IN MILLIMETERS.
2. DIMENSIONING AND TOLERANCING PER ASME Y14.5M-1994.
3. PIN A1 FEATURE SHAPE, SIZE AND LOCATION MAY VARY.
4. MAXIMUM SOLDER BALL DIAMETER MEASURED PARALLEL TO DATUM C.
5. DATUM C, THE SEATING PLANE, IS DETERMINED BY THE SPHERICAL CROWNS OF THE SOLDER BALLS.
6. PARALLELISM MEASUREMENT SHALL EXCLUDE ANY EFFECT OF MARK ON TOP SURFACE OF PACKAGE.

© NXP B.V. ALL RIGHTS RESERVED

DATE: 26 SEP 2018

| | | | | |
|--|------------------------|--------------------------------|----------------|--|
| MECHANICAL OUTLINE PRINT VERSION NOT TO SCALE | STANDARD: NON JEDEC | DRAWING NUMBER: 98ASA01278D | REVISION: A | |
|--|------------------------|--------------------------------|----------------|--|

Figure 48. VFBGA98 Soldering footprint part 4

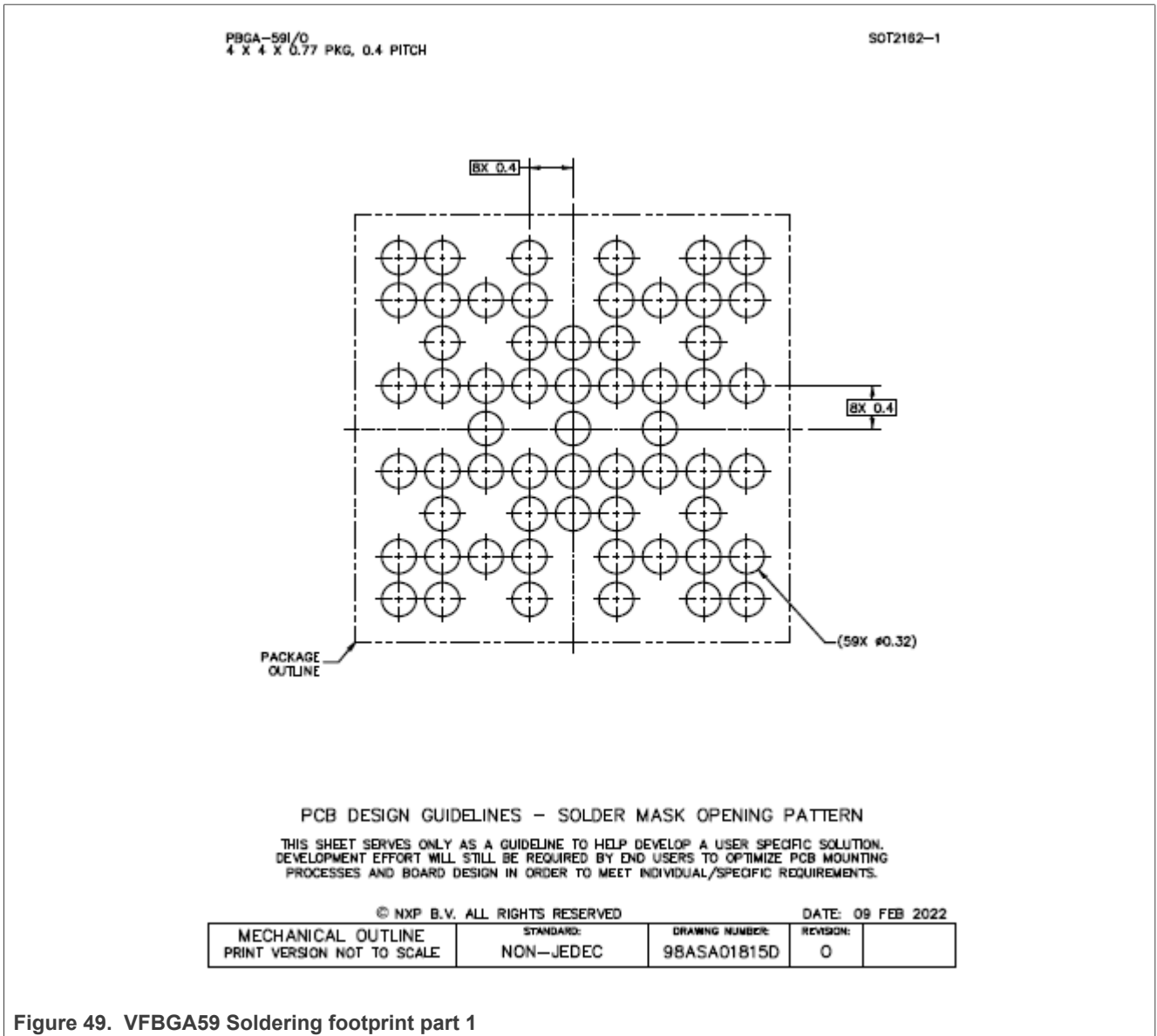

Figure 49. VFBGA59 Soldering footprint part 1

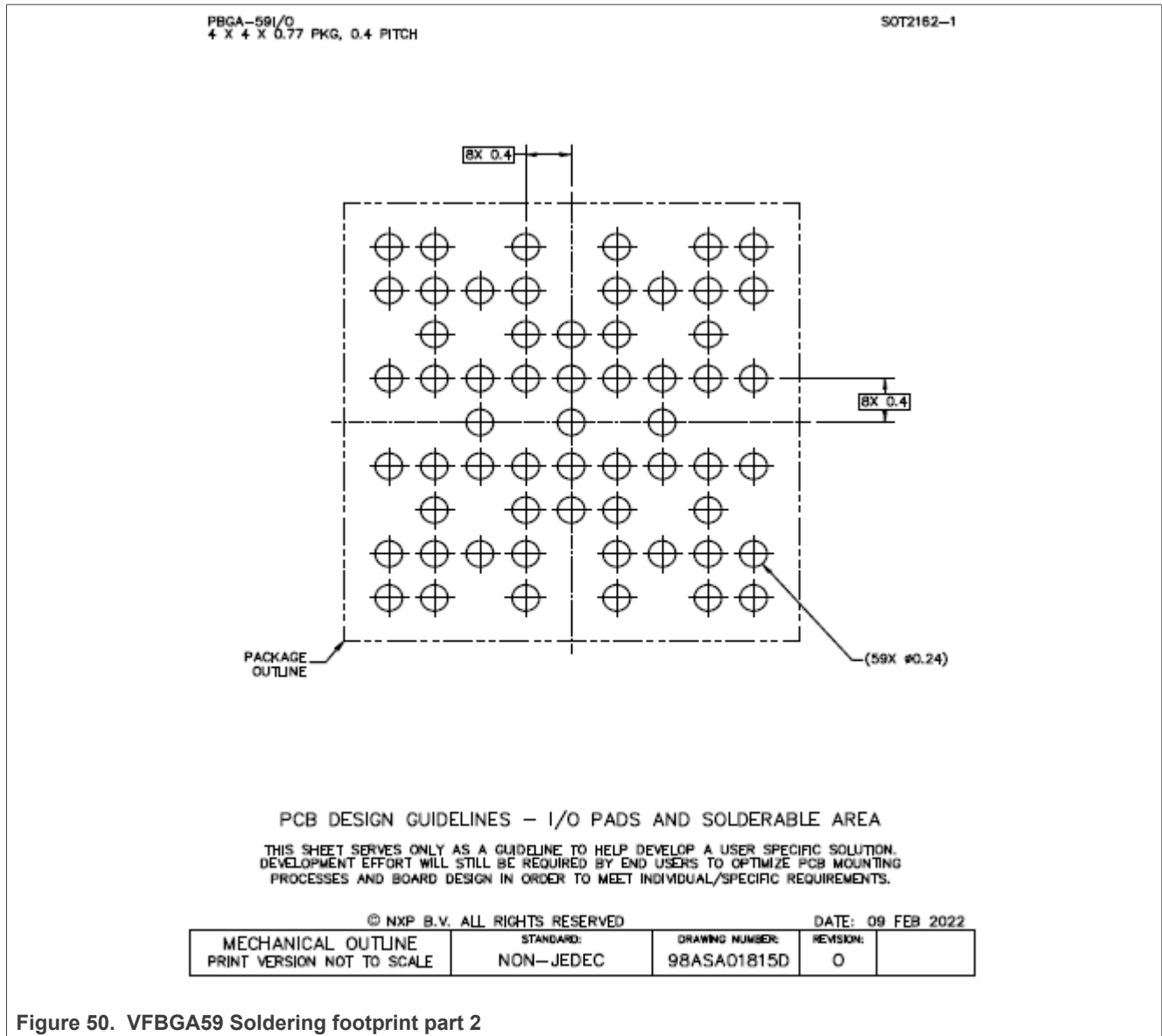

Figure 50. VFBGA59 Soldering footprint part 2

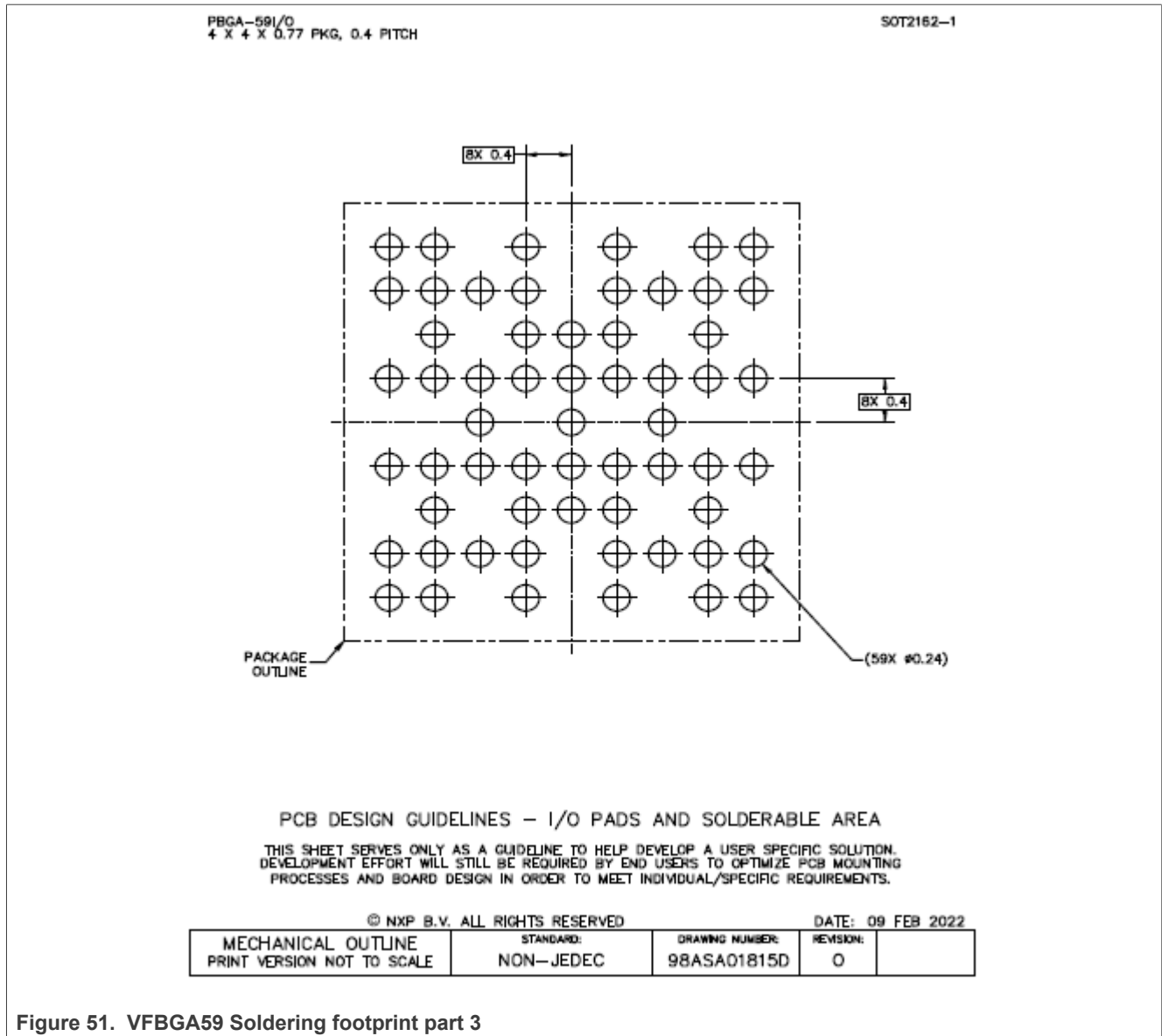

Figure 51. VFBGA59 Soldering footprint part 3

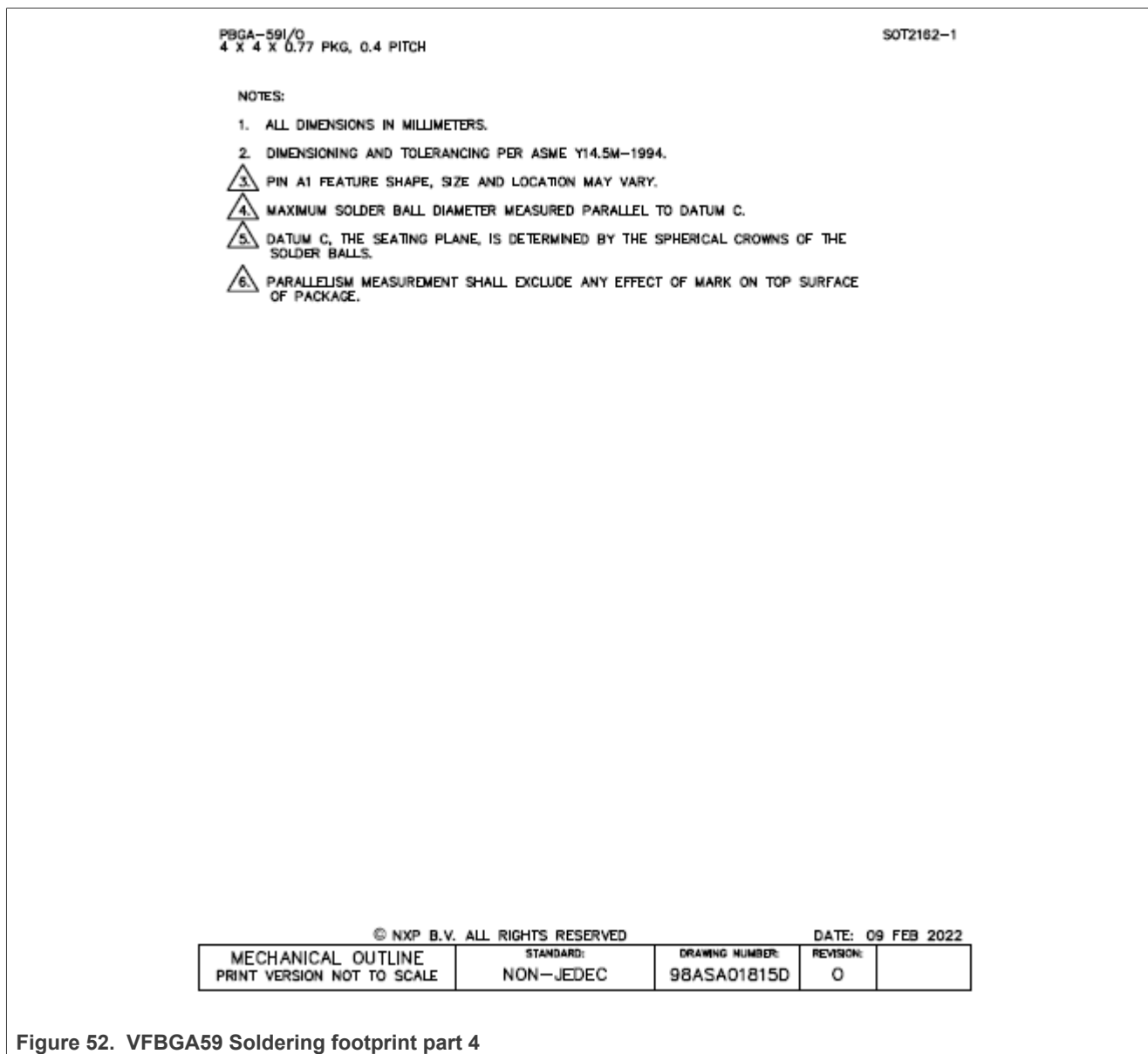

Figure 52. VFBGA59 Soldering footprint part 4

16 Abbreviations

Table 48. Abbreviations

| Acronym | Description |
|----------------|--|
| AHB | Advanced High-performance Bus |
| APB | Advanced Peripheral Bus |
| API | Application Programming Interface |
| DMA | Direct Memory Access |
| FRO oscillator | Internal Free-Running Oscillator, tuned to the factory specified frequency |
| GPIO | General Purpose Input/Output |
| FRO | Free Running Oscillator |

Table 48. Abbreviations...continued

| Acronym | Description |
|---------|---|
| LSB | Least Significant Bit |
| MCU | MicroController Unit |
| PDM | Pulse Density Modulation |
| PLL | Phase-Locked Loop |
| SPI | Serial Peripheral Interface |
| TCP/IP | Transmission Control Protocol/Internet Protocol |
| TTL | Transistor-Transistor Logic |
| USART | Universal Asynchronous Receiver/Transmitter |

17 Revision history

Table 49. Revision history

| Document ID | Release date | Data sheet status | Change notice | Supersedes |
|---------------|--------------|---|---------------|------------|
| LPC55S6x v2.5 | 20240829 | Product data sheet | | v2.4 |
| | | <ul style="list-style-type: none"> Shortened the descriptive title of the document. Added VFBGA59 package details in Section 4. Added VFBGA59 package details in Table 1 and Table 2. Added pin description for 59 pin VFBGA in Table 3. Added VFBGA59 in Table 11. Added VFBGA59 package in Table 12. Added VFBGA59 package outline and soldering information in Section 14 and Section 15. Updated the 'First line' under HLQFP100 package marking in Section 4. Added SDIO delay_i and delay_o parameters in Section 11.14. | | |
| LPC55S6x v2.4 | 20221208 | Product data sheet | 2022120171 | v2.3 |
| | | <ul style="list-style-type: none"> Updated crystal oscillator frequency from 1 MHz to 12 MHz and clock frequencies from 24 MHz to 25 MHz in Section 7.22.1. In Section 13.3 updated maximum frequency up to 25 MHz. Updated endpoints to 12 physical (6 logical) in Section 7.26.2.1. Updated recommended termination of unused pins for XTAL32M_P in Table 4. In Table 4, updated pin USBn_3V3 to read "when not using USB, pin can be connected to ground as well". USART3 and OSTIMER data added in Table 20. Added Section 13.1. Added Figure 2. Added Table 17. Updated minimum, maximum, and unit value of common to master and slave in Table 35. In footnote 7 of Table 42 added "For best performance, force the offset calibration to -16. Set this prior to performing the gain calibration". Added Section 13.5. In Table 3, added "Maximum frequency on PLU clock input is 25 MHz" for PLU_CLKIN: PIO0_21 and PIO1_25. In Table 3 updated "Table note 3". In this table note, removed "Pulse width of spikes or glitches suppressed by input filter is from 3 ns to 16 ns (simulated value)". In Table 3 updated "Table note 5", and "Table note 6". Added GPIO logic state in Section 7.23.2 and in Section 7.23.3. | | |

Table 49. Revision history...continued

| Document ID | Release date | Data sheet status | Change notice | Supersedes |
|---------------|--------------|--------------------|---------------|--|
| | | | | <ul style="list-style-type: none"> In Section 7.23.3, added IOCON registers and peripheral registers details. In Section 7.26.3.2, updated maximum supported bit rate for SPI master mode (transmit/receive) to 32 Mbit/s and for SPI slave transmit mode to 16 Mbit/s. In Section 7.26.3.4, updated maximum bit rate to 10 Mbit/s for asynchronous mode and 25 Mbit/s for synchronous mode. Added text "External power supply" in Figure 6. Updated maximum supported bit rate for master and slave synchronous mode in Section 11.11. Updated maximum supported bit rate for master and slave synchronous mode in Section 11.13. Updated T_{jmax} (Device) and T_{jmax} (Silicon Process) details in Table 13. Added new parameter Nupdates in Table 26. In Section 4, replaced "third line" with "Fifth line: zzzzywwxR". Operating frequency of crystal oscillator updated to 16 MHz instead of 12 MHz in Section 2 and Section 7.22.1. Added Table 18. |
| LPC55S6x v2.3 | 20210709 | Product data sheet | 2021080011 | v2.2 |
| | | | | Added new Section 11.1 . |
| LPC55S6x v2.2 | 20210510 | Product data sheet | - | v2.1 |
| | | | | Updated DICE information in Section 1 , Section 2 , Section 7.11 , and added Section 7.31.7 . |
| LPC55S6x v2.1 | 20201209 | Product data sheet | - | v2.0 |
| | | | | SPI and HSPI max bit rates were updated in Section 11.11 , and Section 11.12 . |
| LPC55S6x v2.0 | 20201123 | Product data sheet | - | v1.9 |
| | | | | Updated various sections and added Section 13.6 . The FRO spec was improved to +/- 1% for temp range 0 C to 85 C. |
| LPC55S6x v1.9 | 20200210 | Product data sheet | - | v1.8 |
| | | | | Updated Section 2 for Clock Generation regarding embedded capacitor bank for the crystal oscillator. |
| LPC55S6x v1.8 | 20200122 | Product data sheet | - | v1.7 |
| | | | | Updated Table 20 . |
| LPC55S6x v1.7 | 20191122 | Product data sheet | - | v1.6 |
| | | | | Updated HTQFP64 pin numbering for FB and VSS_DCDC pins See Table 3 Updated Table 26 . |
| LPC55S6x v1.6 | 20191016 | Product data sheet | - | v1.5 |
| | | | | Updated Table 28 Updated Table 14 Updated Section 4 |
| LPC55S6x v1.5 | 20190930 | Product data sheet | - | v1.4 |
| | | | | Updated Table 45 Updated Table 42 Updated Table 44 |
| LPC55S6x v1.4 | 20190722 | Product data sheet | - | v1.3 |

Table 49. Revision history...continued

| Document ID | Release date | Data sheet status | Change notice | Supersedes |
|----------------|---|--------------------|---------------|------------|
| | Added device revision 1B Updated Table 42 | | | |
| LPC55S6x v1.3 | 20190717 | Product data sheet | - | v1.2 |
| | Updated Table 42 Updated Table 23 Updated Figure 10 | | | |
| LPC55S6x v1.2 | 20190702 | Product data sheet | - | v1.1 |
| | Updated Table 42 Updated Table 15 . Updated Table 41 Updated Table 24 Updated Table 20 and Table 16 Updated Table 12 Updated Table 13 Updated Table 14 Updated Table 23 Updated Table 45 Updated Table 43 | | | |
| LPC55S6x v1.1 | 20190402 | Product data sheet | - | v1.0 |
| Modifications: | <ul style="list-style-type: none"> • Updated Table 42 • Updated Table 44 • Updated Table 28 • Updated Table 27. • Updated Table 24 • Updated Table 20. • Updated Table 36, Table 37, and Table 38 | | | |
| LPC55S6x v1.0 | 20190225 | Product data sheet | - | - |

Legal information

Data sheet status

| Document status ^{[1][2]} | Product status ^[3] | Definition |
|-----------------------------------|-------------------------------|---|
| Objective [short] data sheet | Development | This document contains data from the objective specification for product development. |
| Preliminary [short] data sheet | Qualification | This document contains data from the preliminary specification. |
| Product [short] data sheet | Production | This document contains the product specification. |

[1] Please consult the most recently issued document before initiating or completing a design.

[2] The term 'short data sheet' is explained in section "Definitions".

[3] The product status of device(s) described in this document may have changed since this document was published and may differ in case of multiple devices. The latest product status information is available on the Internet at URL <https://www.nxp.com>.

Definitions

Draft — A draft status on a document indicates that the content is still under internal review and subject to formal approval, which may result in modifications or additions. NXP Semiconductors does not give any representations or warranties as to the accuracy or completeness of information included in a draft version of a document and shall have no liability for the consequences of use of such information.

Short data sheet — A short data sheet is an extract from a full data sheet with the same product type number(s) and title. A short data sheet is intended for quick reference only and should not be relied upon to contain detailed and full information. For detailed and full information see the relevant full data sheet, which is available on request via the local NXP Semiconductors sales office. In case of any inconsistency or conflict with the short data sheet, the full data sheet shall prevail.

Product specification — The information and data provided in a Product data sheet shall define the specification of the product as agreed between NXP Semiconductors and its customer, unless NXP Semiconductors and customer have explicitly agreed otherwise in writing. In no event however, shall an agreement be valid in which the NXP Semiconductors product is deemed to offer functions and qualities beyond those described in the Product data sheet.

Disclaimers

Limited warranty and liability — Information in this document is believed to be accurate and reliable. However, NXP Semiconductors does not give any representations or warranties, expressed or implied, as to the accuracy or completeness of such information and shall have no liability for the consequences of use of such information. NXP Semiconductors takes no responsibility for the content in this document if provided by an information source outside of NXP Semiconductors.

In no event shall NXP Semiconductors be liable for any indirect, incidental, punitive, special or consequential damages (including - without limitation - lost profits, lost savings, business interruption, costs related to the removal or replacement of any products or rework charges) whether or not such damages are based on tort (including negligence), warranty, breach of contract or any other legal theory.

Notwithstanding any damages that customer might incur for any reason whatsoever, NXP Semiconductors' aggregate and cumulative liability towards customer for the products described herein shall be limited in accordance with the Terms and conditions of commercial sale of NXP Semiconductors.

Right to make changes — NXP Semiconductors reserves the right to make changes to information published in this document, including without limitation specifications and product descriptions, at any time and without notice. This document supersedes and replaces all information supplied prior to the publication hereof.

Suitability for use — NXP Semiconductors products are not designed, authorized or warranted to be suitable for use in life support, life-critical or safety-critical systems or equipment, nor in applications where failure or malfunction of an NXP Semiconductors product can reasonably be expected to result in personal injury, death or severe property or environmental damage. NXP Semiconductors and its suppliers accept no liability for inclusion and/or use of NXP Semiconductors products in such equipment or applications and therefore such inclusion and/or use is at the customer's own risk.

Applications — Applications that are described herein for any of these products are for illustrative purposes only. NXP Semiconductors makes no representation or warranty that such applications will be suitable for the specified use without further testing or modification.

Customers are responsible for the design and operation of their applications and products using NXP Semiconductors products, and NXP Semiconductors accepts no liability for any assistance with applications or customer product design. It is customer's sole responsibility to determine whether the NXP Semiconductors product is suitable and fit for the customer's applications and products planned, as well as for the planned application and use of customer's third party customer(s). Customers should provide appropriate design and operating safeguards to minimize the risks associated with their applications and products.

NXP Semiconductors does not accept any liability related to any default, damage, costs or problem which is based on any weakness or default in the customer's applications or products, or the application or use by customer's third party customer(s). Customer is responsible for doing all necessary testing for the customer's applications and products using NXP Semiconductors products in order to avoid a default of the applications and the products or of the application or use by customer's third party customer(s). NXP does not accept any liability in this respect.

Limiting values — Stress above one or more limiting values (as defined in the Absolute Maximum Ratings System of IEC 60134) will cause permanent damage to the device. Limiting values are stress ratings only and (proper) operation of the device at these or any other conditions above those given in the Recommended operating conditions section (if present) or the Characteristics sections of this document is not warranted. Constant or repeated exposure to limiting values will permanently and irreversibly affect the quality and reliability of the device.

Terms and conditions of commercial sale — NXP Semiconductors products are sold subject to the general terms and conditions of commercial sale, as published at <https://www.nxp.com/profile/terms>, unless otherwise agreed in a valid written individual agreement. In case an individual agreement is concluded only the terms and conditions of the respective agreement shall apply. NXP Semiconductors hereby expressly objects to applying the customer's general terms and conditions with regard to the purchase of NXP Semiconductors products by customer.

No offer to sell or license — Nothing in this document may be interpreted or construed as an offer to sell products that is open for acceptance or the grant, conveyance or implication of any license under any copyrights, patents or other industrial or intellectual property rights.

Quick reference data — The Quick reference data is an extract of the product data given in the Limiting values and Characteristics sections of this document, and as such is not complete, exhaustive or legally binding.

Export control — This document as well as the item(s) described herein may be subject to export control regulations. Export might require a prior authorization from competent authorities.

Suitability for use in non-automotive qualified products — Unless this document expressly states that this specific NXP Semiconductors product is automotive qualified, the product is not suitable for automotive use. It is neither qualified nor tested in accordance with automotive testing or application requirements. NXP Semiconductors accepts no liability for inclusion and/or use of non-automotive qualified products in automotive equipment or applications.

In the event that customer uses the product for design-in and use in automotive applications to automotive specifications and standards, customer (a) shall use the product without NXP Semiconductors' warranty of the product for such automotive applications, use and specifications, and (b) whenever customer uses the product for automotive applications beyond NXP Semiconductors' specifications such use shall be solely at customer's own risk, and (c) customer fully indemnifies NXP Semiconductors for any liability, damages or failed product claims resulting from customer design and use of the product for automotive applications beyond NXP Semiconductors' standard warranty and NXP Semiconductors' product specifications.

Translations — A non-English (translated) version of a document, including the legal information in that document, is for reference only. The English version shall prevail in case of any discrepancy between the translated and English versions.

Security — Customer understands that all NXP products may be subject to unidentified vulnerabilities or may support established security standards or specifications with known limitations. Customer is responsible for the design and operation of its applications and products throughout their lifecycles to reduce the effect of these vulnerabilities on customer's applications and products. Customer's responsibility also extends to other open and/or proprietary technologies supported by NXP products for use in customer's applications. NXP accepts no liability for any vulnerability. Customer should regularly check security updates from NXP and follow up appropriately.

Customer shall select products with security features that best meet rules, regulations, and standards of the intended application and make the ultimate design decisions regarding its products and is solely responsible for compliance with all legal, regulatory, and security related requirements concerning its products, regardless of any information or support that may be provided by NXP.

NXP has a Product Security Incident Response Team (PSIRT) (reachable at PSIRT@nxp.com) that manages the investigation, reporting, and solution release to security vulnerabilities of NXP products.

NXP B.V. — NXP B.V. is not an operating company and it does not distribute or sell products.

Trademarks

Notice: All referenced brands, product names, service names, and trademarks are the property of their respective owners.

NXP — wordmark and logo are trademarks of NXP B.V.

Contents

| | | | | | |
|----------|---|-----------|----------|---|----|
| 1 | General description | 1 | 7.26.1 | Full-speed USB Host/Device Interface (USB0) | 59 |
| 2 | Features and benefits | 1 | 7.26.1.1 | USB0 device controller | 59 |
| 3 | Ordering information | 4 | 7.26.1.2 | USB0 host controller | 59 |
| 3.1 | Ordering options | 5 | 7.26.2 | High-Speed USB Host/Device Interface (USB1) | 60 |
| 4 | Marking | 5 | 7.26.2.1 | USB1 device controller | 60 |
| 5 | Block diagram | 7 | 7.26.2.2 | USB1 host controller | 60 |
| 6 | Pinning information | 8 | 7.26.3 | Flexcomm Interface serial communication | 60 |
| 6.1 | Pin description | 8 | 7.26.3.1 | Features | 60 |
| 6.1.1 | Termination of unused pins | 45 | 7.26.3.2 | SPI serial I/O (SPI0) controller | 61 |
| 6.1.2 | Using Internal DC-DC converter | 46 | 7.26.3.3 | I2C-bus interface | 61 |
| 7 | Functional description | 46 | 7.26.3.4 | USART | 61 |
| 7.1 | Architectural overview | 46 | 7.26.3.5 | I2S-bus interface | 62 |
| 7.2 | Arm Cortex-M33 processor (CPU0) | 47 | 7.26.4 | High-speed SPI serial I/O controller | 63 |
| 7.3 | Arm Cortex-M33 integrated Floating Point Unit (FPU) | 47 | 7.26.4.1 | Features | 63 |
| 7.4 | Arm Cortex-M33 (CPU1) | 47 | 7.27 | SDIO/MMC interface | 63 |
| 7.5 | Memory Protection Unit (MPU) | 47 | 7.27.1 | Features | 63 |
| 7.6 | Nested Vectored Interrupt Controller (NVIC) for Cortex-M33 (CPU0) | 47 | 7.28 | Standard counter/timers (CT32B0 to 4) | 63 |
| 7.6.1 | Features | 47 | 7.28.1 | Features | 63 |
| 7.6.2 | Interrupt sources | 48 | 7.28.2 | SCTimer/PWM subsystem | 64 |
| 7.7 | Nested Vectored Interrupt Controller (NVIC) for Cortex-M33 (CPU1) | 48 | 7.28.2.1 | Features | 64 |
| 7.7.1 | Features | 48 | 7.28.3 | Windowed WatchDog Timer (WWDT) | 65 |
| 7.7.2 | Interrupt sources | 48 | 7.28.3.1 | Features | 65 |
| 7.8 | System Tick timer (SysTick) | 48 | 7.28.4 | RTC timer | 66 |
| 7.9 | On-chip static RAM | 48 | 7.28.4.1 | Features | 66 |
| 7.10 | On-chip flash | 48 | 7.28.5 | Multi-Rate Timer (MRT) | 66 |
| 7.11 | On-chip ROM | 48 | 7.28.5.1 | Features | 66 |
| 7.12 | Protected Flash Region (PFR) | 49 | 7.28.6 | OS Timer | 66 |
| 7.13 | Memory mapping | 49 | 7.28.6.1 | Features | 66 |
| 7.14 | AHB multilayer matrix | 49 | 7.28.7 | Micro-tick timer (UTICK) | 66 |
| 7.15 | Memory Protection Unit (MPU) | 49 | 7.28.7.1 | Features | 67 |
| 7.16 | TrustZone and system mapping on this device | 49 | 7.29 | Digital peripherals | 67 |
| 7.17 | Links to specific memory map descriptions and tables: | 50 | 7.29.1 | DMA controller | 67 |
| 7.18 | Memory map overview | 50 | 7.29.1.1 | Features | 67 |
| 7.19 | APB peripherals | 51 | 7.29.2 | Programmable Logic Unit (PLU) | 67 |
| 7.20 | AHB peripherals | 52 | 7.29.2.1 | Features | 67 |
| 7.21 | RAM configuration | 53 | 7.29.3 | CRC engine | 68 |
| 7.22 | System control | 53 | 7.29.3.1 | Features | 68 |
| 7.22.1 | Clock sources | 53 | 7.30 | Analog peripherals | 68 |
| 7.22.2 | PLL (PLL0 and PLL1) | 54 | 7.30.1 | 16-bit Analog-to-Digital Converter (ADC) | 68 |
| 7.22.3 | Clock generation | 54 | 7.30.1.1 | Features | 68 |
| 7.22.4 | Brownout detection | 56 | 7.30.2 | Comparator | 69 |
| 7.23 | Power control | 57 | 7.30.2.1 | Features | 69 |
| 7.23.1 | Sleep mode | 57 | 7.30.3 | Temperature sensor | 69 |
| 7.23.2 | Deep-sleep mode | 57 | 7.31 | Security Features | 69 |
| 7.23.3 | Power-down mode | 57 | 7.31.1 | AES engine | 70 |
| 7.23.4 | Deep power-down mode | 58 | 7.31.1.1 | Features | 70 |
| 7.24 | General Purpose I/O (GPIO) | 58 | 7.31.2 | HASH engine | 70 |
| 7.24.1 | Features | 58 | 7.31.2.1 | Features | 70 |
| 7.25 | Pin interrupt/pattern engine | 58 | 7.31.3 | PUF | 70 |
| 7.25.1 | Features | 58 | 7.31.3.1 | Features | 70 |
| 7.26 | Communication peripherals | 59 | 7.31.4 | Random Number Generator | 71 |
| | | | 7.31.5 | PRINCE On-the-fly encryption/decryption | 71 |
| | | | 7.31.6 | Universally Unique Identifier (UUID) | 71 |

| | | |
|-----------|---|------------|
| 7.31.7 | Device Identifier Composition Engine (DICE) | 71 |
| 7.32 | Debug Mailbox and Authentication | 71 |
| 7.33 | Emulation and debugging | 72 |
| 8 | Limiting values | 72 |
| 9 | Thermal characteristics | 73 |
| 10 | Static characteristics | 74 |
| 10.1 | General operating conditions | 74 |
| 10.2 | CoreMark data | 75 |
| 10.3 | Power consumption | 76 |
| 10.3.1 | Peripheral Power Consumption | 81 |
| 10.4 | Pin characteristics | 83 |
| 11 | Dynamic characteristics | 85 |
| 11.1 | Power-up ramp conditions | 85 |
| 11.2 | Flash memory | 85 |
| 11.3 | I/O pins | 86 |
| 11.4 | Wake-up process | 86 |
| 11.5 | FRO (12 MHz/96 MHz) | 87 |
| 11.6 | FRO (1 MHz) | 87 |
| 11.7 | FRO (32 KHz) | 87 |
| 11.8 | RTC oscillator | 87 |
| 11.9 | I2C-bus | 88 |
| 11.10 | I2S-bus interface | 89 |
| 11.11 | SPI interface (Flexcomm Interfaces 0 - 7) | 91 |
| 11.12 | High-Speed SPI interface (Flexcomm Interface 8) | 93 |
| 11.13 | USART interface | 95 |
| 11.14 | SD/MMC and SDIO | 96 |
| 12 | Analog characteristics | 97 |
| 12.1 | BODVBAT | 97 |
| 12.2 | 16-bit ADC characteristics | 98 |
| 12.2.1 | ADC input resistance (Please refer to the ADC Inputs Selection & ADC programming table in the UM) | 99 |
| 12.3 | Temperature sensor | 100 |
| 12.4 | Comparator | 100 |
| 13 | Application information | 102 |
| 13.1 | Start-up behavior | 102 |
| 13.2 | I/O power consumption | 102 |
| 13.3 | Crystal oscillator | 103 |
| 13.3.1 | Crystal Printed Circuit Board (PCB) design guidelines | 103 |
| 13.4 | RTC oscillator | 104 |
| 13.4.1 | RTC Printed Circuit Board (PCB) design guidelines | 104 |
| 13.5 | Suggested USB Full-speed interface solutions | 104 |
| 13.6 | USB1 High-speed VBUS threshold levels | 106 |
| 14 | Package outline | 107 |
| 15 | Soldering | 113 |
| 16 | Abbreviations | 128 |
| 17 | Revision history | 129 |
| | Legal information | 132 |

Please be aware that important notices concerning this document and the product(s) described herein, have been included in section 'Legal information'.

OUR CERTIFICATE

DiGi provide top-quality products and perfect service for customer worldwide through standardization, technological innovation and continuous improvement. DiGi through third-party certification, we stricly control the quality of products and services. Welcome your RFQ to

Email: Info@DiGi-Electronics.com



Tel: +00 852-30501935

RFQ Email: Info@DiGi-Electronics.com

DiGi is a global authorized distributor of electronic components.