

SPC5553MVZ132 Datasheet

www.digi-electronics.com

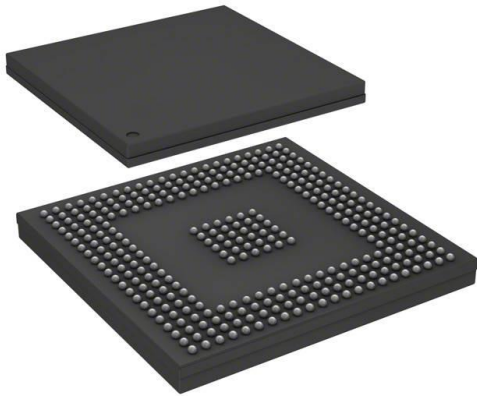

<https://www.DiGi-Electronics.com>

DiGi Electronics Part Number	SPC5553MVZ132-DG
Manufacturer	NXP USA Inc.
Manufacturer Product Number	SPC5553MVZ132
Description	IC MCU 32BIT 1.5KB FLASH 324PBGA
Detailed Description	e200z6 MPC55xx Qorivva Microcontroller IC 32-Bit Single-Core 132MHz 1.5KB (1.5K x 8) FLASH 324-PBGA (23x23)

This model SPC5553MVZ132 is available at DiGi Electronics.

DiGi Electronics offers a global database of semiconductor and electronic component datasheets.

We welcome your inquiries regarding pricing, lead time, or other product-related questions.

 [Request a Quote](#)

 [Datasheet Search](#)



Tel: +00 852-30501935

RFQ Email: Info@DiGi-Electronics.com

DiGi is a global authorized distributor of electronic components.

Purchase and inquiry

Manufacturer Product Number:

SPC5553MVZ132

Series:

MPC55xx Qorivva

DiGi-Electronics Programmable:

Not Verified

Core Size:

32-Bit Single-Core

Connectivity:

CANbus, EBI/EMI, Ethernet, SCI, SPI

Number of I/O:

220

Program Memory Type:

FLASH

RAM Size:

64K x 8

Data Converters:

A/D 40x12b

Operating Temperature:

-40°C ~ 125°C (TA)

Supplier Device Package:

324-PBGA (23x23)

Base Product Number:

SPC5553

Manufacturer:

NXP USA Inc.

Product Status:

Active

Core Processor:

e200z6

Speed:

132MHz

Peripherals:

DMA, POR, PWM, WDT

Program Memory Size:

1.5KB (1.5K x 8)

EEPROM Size:

-

Voltage - Supply (Vcc/Vdd):

1.35V ~ 1.65V

Oscillator Type:

External

Mounting Type:

Surface Mount

Package / Case:

324-BBGA

Environmental & Export classification

RoHS Status:

ROHS3 Compliant

REACH Status:

REACH Unaffected

HTSUS:

8542.31.0001

Moisture Sensitivity Level (MSL):

3 (168 Hours)

ECCN:

3A991A2

MPC5553

Microcontroller Data Sheet

by: Microcontroller Division

This document provides electrical specifications, pin assignments, and package diagrams for the MPC5553 microcontroller device. For functional characteristics, refer to the *MPC5553/MPC5554 Microcontroller Reference Manual*.

1 Overview

The MPC5553 microcontroller (MCU) is a member of the MPC5500 family of microcontrollers built on the Power Architecture[®] embedded technology. This family of parts has many new features coupled with high performance CMOS technology to provide substantial reduction of cost per feature and significant performance improvement over the MPC500 family.

The host processor core of this device complies with the Power Architecture embedded category that is 100% user-mode compatible (including floating point library) with the original PowerPC instruction set. The embedded architecture enhancements improve the performance in embedded applications. The core also has additional instructions, including digital signal processing (DSP) instructions, beyond the original PowerPC instruction set.

Contents

1	Overview	1
2	Ordering Information	3
3	Electrical Characteristics	4
3.1	Maximum Ratings	4
3.2	Thermal Characteristics	6
3.3	Package	9
3.4	EMI (Electromagnetic Interference) Characteristics	9
3.5	ESD (Electromagnetic Static Discharge) Characteristics	10
3.6	Voltage Regulator Controller (VRC) and Power-On Reset (POR) Electrical Specifications	10
3.7	Power-Up/Down Sequencing	11
3.8	DC Electrical Specifications	15
3.9	Oscillator and FMPLL Electrical Characteristics	21
3.10	eQADC Electrical Characteristics	23
3.11	H7Fa Flash Memory Electrical Characteristics	24
3.12	AC Specifications	25
3.13	AC Timing	27
3.14	Fast Ethernet AC Timing Specifications	46
4	Mechanicals	50
4.1	MPC5553 208 MAP BGA Pinout	50
4.2	MPC5553 324 PBGA Pinouts	51
4.3	MPC5553 416 PBGA Pinout	51
4.4	MPC5553 208-Pin Package Dimensions	55
4.5	MPC5553 324-Pin Package Dimensions	57
4.6	MPC5553 416-Pin Package Dimensions	59
5	Revision History for the MPC5553 Data Sheet	61
5.1	Information Changed Between Revisions 3.0 and 4.0	61
5.2	Information Changed Between Revisions 2.0 and 3.0	61

Overview

The MPC5500 family of parts contains many new features coupled with high performance CMOS technology to provide significant performance improvement over the MPC565.

The MPC5553 has two levels of memory hierarchy. The fastest accesses are to the 8-kilobytes (KB) unified cache. The next level in the hierarchy contains the 64-KB on-chip internal SRAM and 1.5-megabytes (MB) internal flash memory. The internal SRAM and flash memory hold instructions and data. The external bus interface is designed to support most of the standard memories used with the MPC5xx family.

The complex input/output timer functions of the MPC5553 are performed by an enhanced time processor unit (eTPU) engine. The eTPU engine controls 32 hardware channels. The eTPU has been enhanced over the TPU by providing: 24-bit timers, double-action hardware channels, variable number of parameters per channel, angle clock hardware, and additional control and arithmetic instructions. The eTPU is programmed using a high-level programming language.

The less complex timer functions of the MPC5553 are performed by the enhanced modular input/output system (eMIOS). The eMIOS' 24 hardware channels are capable of single-action, double-action, pulse-width modulation (PWM), and modulus-counter operations. Motor control capabilities include edge-aligned and center-aligned PWM.

Off-chip communication is performed by a suite of serial protocols including controller area networks (FlexCANs), enhanced deserial/serial peripheral interfaces (DSPIs), and enhanced serial communications interfaces (eSCIs).

The MCU has an on-chip enhanced queued dual analog-to-digital converter (eQADC). The 324 and 416 packages have 40-channels.

The system integration unit (SIU) performs several chip-wide configuration functions. Pad configuration and general-purpose input and output (GPIO) are controlled from the SIU. External interrupts and reset control are also determined by the SIU. The internal multiplexer submodule (SIU_DISR) provides multiplexing of eQADC trigger sources and external interrupt signal multiplexing.

The Fast Ethernet (FEC) module is a RISC-based controller that supports both 10 and 100 Mbps Ethernet/IEEE® 802.3 networks and is compatible with three different standard MAC (media access controller) PHY (physical) interfaces to connect to an external Ethernet bus. The FEC supports the 10 or 100 Mbps MII (media independent interface), and the 10 Mbps-only with a seven-wire interface, which uses a subset of the MII signals. The upper 16-bits of the 32-bit external bus interface (EBI) are used to connect to an external Ethernet device. The FEC contains built-in transmit and receive message FIFOs and DMA support.

2 Ordering Information

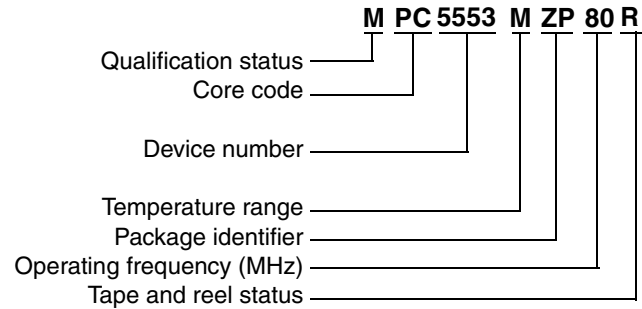

Temperature Range
M = -40° C to 125° C

Package Identifier
ZP = 416PBGA SnPb
VR = 416PBGA Pb-free
VF = 208MAPBGA SnPb
VM = 208MAPBGA Pb-free
ZQ = 324PBGA SnPb
VZ = 324PBGA Pb-free

Operating Frequency
80 = 80 MHz
112 = 112 MHz
132 = 132 MHz

Tape and Reel Status
R = Tape and reel
(blank) = Trays

Qualification Status

P = Pre qualification
M = Fully spec. qualified, general market flow
S = Fully spec. qualified, automotive flow

Note: Not all options are available on all devices. Refer to [Table 1](#).

Figure 1. MPC5500 Family Part Number Example

Unless noted in this data sheet, all specifications apply from T_L to T_H .

Table 1. Orderable Part Numbers

Freescale Part Number ¹	Package Description	Speed (MHz)		Operating Temperature ²	
		Nominal	Max. ³ (f_{MAX})	Min. (T_L)	Max. (T_H)
MPC5553MVR132	MPC5553 416 package Lead-free (Pb-free)	132	132	-40° C	125° C
MPC5553MVR112		112	114		
MPC5553MVR80		80	82		
MPC5553MVZ132	MPC5553 324 package Lead-free (Pb-free)	132	132	-40° C	125° C
MPC5553MVZ112		112	114		
MPC5553MVZ80		80	82		
MPC5553MVM132	MPC5553 208 package Lead-free (Pb-free)	132	132	-40° C	125° C
MPC5553MVM112		112	114		
MPC5553MVM80		80	82		
MPC5553MZP132	MPC5553 416 package Leaded (SnPb)	132	132	-40° C	125° C
MPC5553MZP112		112	114		
MPC5553MZP80		80	82		
MPC5553MZQ132	MPC5553 324 package Leaded (SnPb)	132	132	-40° C	125° C
MPC5553MZQ112		112	114		
MPC5553MZQ80		80	82		

Electrical Characteristics
Table 1. Orderable Part Numbers (continued)

Freescale Part Number ¹	Package Description	Speed (MHz)		Operating Temperature ²	
		Nominal	Max. ³ (f _{MAX})	Min. (T _L)	Max. (T _H)
MPC5553MVF132	MPC5553 208 package Leaded (SnPb)	132	132	-40° C	125° C
MPC5553MVF112		112	114		
MPC5553MVF80		80	82		

¹ All devices are PPC5553, rather than MPC5553 or SPC5553, until product qualifications are complete. Not all configurations are available in the PPC parts.

² The lowest ambient operating temperature is referenced by T_L; the highest ambient operating temperature is referenced by T_H.

³ Speed is the nominal maximum frequency. Max. speed is the maximum speed allowed including frequency modulation (FM). 82 MHz parts allow for 80 MHz system clock + 2% FM; 114 MHz parts allow for 112 MHz system clock + 2% FM; and 132 MHz parts allow for 128 MHz system clock + 2% FM.

3 Electrical Characteristics

This section contains detailed information on power considerations, DC/AC electrical characteristics, and AC timing specifications for the MCU.

3.1 Maximum Ratings

Table 2. Absolute Maximum Ratings¹

Spec	Characteristic	Symbol	Min.	Max.	Unit
1	1.5 V core supply voltage ²	V _{DD}	-0.3	1.7	V
2	Flash program/erase voltage	V _{PP}	-0.3	6.5	V
4	Flash read voltage	V _{FLASH}	-0.3	4.6	V
5	SRAM standby voltage	V _{STBY}	-0.3	1.7	V
6	Clock synthesizer voltage	V _{DDSYN}	-0.3	4.6	V
7	3.3 V I/O buffer voltage	V _{DD33}	-0.3	4.6	V
8	Voltage regulator control input voltage	V _{RC33}	-0.3	4.6	V
9	Analog supply voltage (reference to V _{SSA})	V _{DDA}	-0.3	5.5	V
10	I/O supply voltage (fast I/O pads) ³	V _{DDE}	-0.3	4.6	V
11	I/O supply voltage (slow and medium I/O pads) ³	V _{DDEH}	-0.3	6.5	V
12	DC input voltage ⁴ V _{DDEH} powered I/O pads V _{DDE} powered I/O pads	V _{IN}	-1.0 ⁵ -1.0 ⁵	6.5 ⁶ 4.6 ⁷	V
13	Analog reference high voltage (reference to V _{RL})	V _{RH}	-0.3	5.5	V
14	V _{SS} to V _{SSA} differential voltage	V _{SS} - V _{SSA}	-0.1	0.1	V
15	V _{DD} to V _{DDA} differential voltage	V _{DD} - V _{DDA}	-V _{DDA}	V _{DD}	V
16	V _{REF} differential voltage	V _{RH} - V _{RL}	-0.3	5.5	V
17	V _{RH} to V _{DDA} differential voltage	V _{RH} - V _{DDA}	-5.5	5.5	V
18	V _{RL} to V _{SSA} differential voltage	V _{RL} - V _{SSA}	-0.3	0.3	V

Table 2. Absolute Maximum Ratings ¹ (continued)

Spec	Characteristic	Symbol	Min.	Max.	Unit
19	V_{DDEH} to V_{DDA} differential voltage	$V_{DDEH} - V_{DDA}$	$-V_{DDA}$	V_{DDEH}	V
20	V_{DDF} to V_{DD} differential voltage	$V_{DDF} - V_{DD}$	-0.3	0.3	V
21	V_{RC33} to V_{DDSYN} differential voltage spec has been moved to Table 9 DC Electrical Specifications, Spec 43a .				
22	V_{SSSYN} to V_{SS} differential voltage	$V_{SSSYN} - V_{SS}$	-0.1	0.1	V
23	V_{RCVSS} to V_{SS} differential voltage	$V_{RCVSS} - V_{SS}$	-0.1	0.1	V
24	Maximum DC digital input current ⁸ (per pin, applies to all digital pins) ⁴	I_{MAXD}	-2	2	mA
25	Maximum DC analog input current ⁹ (per pin, applies to all analog pins)	I_{MAXA}	-3	3	mA
26	Maximum operating temperature range ¹⁰ Die junction temperature	T_J	T_L	150.0	°C
27	Storage temperature range	T_{STG}	-55.0	150.0	°C
28	Maximum solder temperature ¹¹ Lead free (Pb-free) Leaded (SnPb)	T_{SDR}	— —	260.0 245.0	°C
29	Moisture sensitivity level ¹²	MSL	—	3	

¹ Functional operating conditions are given in the DC electrical specifications. Absolute maximum ratings are stress ratings only, and functional operation at the maxima is not guaranteed. Stress beyond any of the listed maxima can affect device reliability or cause permanent damage to the device.

² 1.5 V \pm 10% for proper operation. This parameter is specified at a maximum junction temperature of 150 °C.

³ All functional non-supply I/O pins are clamped to V_{SS} and V_{DDE} , or V_{DDEH} .

⁴ AC signal overshoot and undershoot of up to ± 2.0 V of the input voltages is permitted for an accumulative duration of 60 hours over the complete lifetime of the device (injection current not limited for this duration).

⁵ Internal structures hold the voltage greater than -1.0 V if the injection current limit of 2 mA is met. Keep the negative DC voltage greater than -0.6 V on SINB during the internal power-on reset (POR) state.

⁶ Internal structures hold the input voltage less than the maximum voltage on all pads powered by V_{DDEH} supplies, if the maximum injection current specification is met (2 mA for all pins) and V_{DDEH} is within the operating voltage specifications.

⁷ Internal structures hold the input voltage less than the maximum voltage on all pads powered by V_{DDE} supplies, if the maximum injection current specification is met (2 mA for all pins) and V_{DDE} is within the operating voltage specifications.

⁸ Total injection current for all pins (including both digital and analog) must not exceed 25 mA.

⁹ Total injection current for all analog input pins must not exceed 15 mA.

¹⁰ Lifetime operation at these specification limits is not guaranteed.

¹¹ Moisture sensitivity profile per IPC/JEDEC J-STD-020D.

¹² Moisture sensitivity per JEDEC test method A112.

Electrical Characteristics

3.2 Thermal Characteristics

The shaded rows in the following table indicate information specific to a four-layer board.

Table 3. MPC5553 Thermal Characteristics

Spec	MPC5553 Thermal Characteristic	Symbol	Packages			Unit
			208 MAPBGA	324 PBGA	416 PBGA	
1	Junction to ambient, natural convection (one-layer board) ^{1, 2}	$R_{\theta JA}$	41	30	29	°C/W
2	Junction to ambient, natural convection ^{1, 3} (four-layer board 2s2p)	$R_{\theta JA}$	25	21	21	°C/W
3	Junction to ambient (@200 ft./min., one-layer board)	$R_{\theta JMA}$	33	24	23	°C/W
4	Junction to ambient (@200 ft./min., four-layer board 2s2p)	$R_{\theta JMA}$	22	17	18	°C/W
5	Junction to board (four-layer board 2s2p) ⁴	$R_{\theta JB}$	15	12	13	°C/W
6	Junction to case ⁵	$R_{\theta JC}$	7	8	9	°C/W
7	Junction to package top, natural convection ⁶	Ψ_{JT}	2	2	2	°C/W

¹ Junction temperature is a function of on-chip power dissipation, package thermal resistance, mounting site (board) temperature, ambient temperature, air flow, power dissipation of other components on the board, and board thermal resistance.

² Per SEMI G38-87 and JEDEC JESD51-2 with the single-layer board horizontal.

³ Per JEDEC JESD51-6 with the board horizontal.

⁴ Thermal resistance between the die and the printed circuit board per JEDEC JESD51-8. Board temperature is measured on the top surface of the board near the package.

⁵ Indicates the average thermal resistance between the die and the case top surface as measured by the cold plate method (MIL SPEC-883 Method 1012.1) with the cold plate temperature used for the case temperature.

⁶ Thermal characterization parameter indicating the temperature difference between package top and the junction temperature per JEDEC JESD51-2.

3.2.1 General Notes for Specifications at Maximum Junction Temperature

An estimation of the device junction temperature, T_J , can be obtained from the equation:

$$T_J = T_A + (R_{\theta JA} \times P_D)$$

where:

T_A = ambient temperature for the package (°C)

$R_{\theta JA}$ = junction to ambient thermal resistance (°C/W)

P_D = power dissipation in the package (W)

The thermal resistance values used are based on the JEDEC JESD51 series of standards to provide consistent values for estimations and comparisons. The difference between the values determined for the single-layer (1s) board compared to a four-layer board that has two signal layers, a power and a ground plane (2s2p), demonstrate that the effective thermal resistance is not a constant. The thermal resistance depends on the:

- Construction of the application board (number of planes)
- Effective size of the board which cools the component
- Quality of the thermal and electrical connections to the planes

- Power dissipated by adjacent components

Connect all the ground and power balls to the respective planes with one via per ball. Using fewer vias to connect the package to the planes reduces the thermal performance. Thinner planes also reduce the thermal performance. When the clearance between the vias leave the planes virtually disconnected, the thermal performance is also greatly reduced.

As a general rule, the value obtained on a single-layer board is within the normal range for the tightly packed printed circuit board. The value obtained on a board with the internal planes is usually within the normal range if the application board has:

- One oz. (35 micron nominal thickness) internal planes
- Components are well separated
- Overall power dissipation on the board is less than 0.02 W/cm^2

The thermal performance of any component depends on the power dissipation of the surrounding components. In addition, the ambient temperature varies widely within the application. For many natural convection and especially closed box applications, the board temperature at the perimeter (edge) of the package is approximately the same as the local air temperature near the device. Specifying the local ambient conditions explicitly as the board temperature provides a more precise description of the local ambient conditions that determine the temperature of the device.

Electrical Characteristics

At a known board temperature, the junction temperature is estimated using the following equation:

$$T_J = T_B + (R_{\theta JB} \times P_D)$$

where:

T_J = junction temperature ($^{\circ}\text{C}$)

T_B = board temperature at the package perimeter ($^{\circ}\text{C/W}$)

$R_{\theta JB}$ = junction-to-board thermal resistance ($^{\circ}\text{C/W}$) per JESD51-8

P_D = power dissipation in the package (W)

When the heat loss from the package case to the air does not factor into the calculation, an acceptable value for the junction temperature is predictable. Ensure the application board is similar to the thermal test condition, with the component soldered to a board with internal planes.

The thermal resistance is expressed as the sum of a junction-to-case thermal resistance plus a case-to-ambient thermal resistance:

$$R_{\theta JA} = R_{\theta JC} + R_{\theta CA}$$

where:

$R_{\theta JA}$ = junction-to-ambient thermal resistance ($^{\circ}\text{C/W}$)

$R_{\theta JC}$ = junction-to-case thermal resistance ($^{\circ}\text{C/W}$)

$R_{\theta CA}$ = case-to-ambient thermal resistance ($^{\circ}\text{C/W}$)

$R_{\theta JC}$ is device related and is not affected by other factors. The thermal environment can be controlled to change the case-to-ambient thermal resistance, $R_{\theta CA}$. For example, change the air flow around the device, add a heat sink, change the mounting arrangement on the printed circuit board, or change the thermal dissipation on the printed circuit board surrounding the device. This description is most useful for packages with heat sinks where 90% of the heat flow is through the case to heat sink to ambient. For most packages, a better model is required.

A more accurate two-resistor thermal model can be constructed from the junction-to-board thermal resistance and the junction-to-case thermal resistance. The junction-to-case thermal resistance describes when using a heat sink or where a substantial amount of heat is dissipated from the top of the package. The junction-to-board thermal resistance describes the thermal performance when most of the heat is conducted to the printed circuit board. This model can be used to generate simple estimations and for computational fluid dynamics (CFD) thermal models.

To determine the junction temperature of the device in the application on a prototype board, use the thermal characterization parameter (Ψ_{JT}) to determine the junction temperature by measuring the temperature at the top center of the package case using the following equation:

$$T_J = T_T + (\Psi_{JT} \times P_D)$$

where:

T_T = thermocouple temperature on top of the package ($^{\circ}\text{C}$)

Ψ_{JT} = thermal characterization parameter ($^{\circ}\text{C/W}$)

P_D = power dissipation in the package (W)

The thermal characterization parameter is measured in compliance with the JESD51-2 specification using a 40-gauge type T thermocouple epoxied to the top center of the package case. Position the thermocouple so that the thermocouple junction rests on the package. Place a small amount of epoxy on the thermocouple junction and approximately 1 mm of wire extending from the junction. Place the thermocouple wire flat against the package case to avoid measurement errors caused by the cooling effects of the thermocouple wire.

References:

Semiconductor Equipment and Materials International
 3081 Zanker Rd.
 San Jose, CA., 95134
 (408) 943-6900

MIL-SPEC and EIA/JESD (JEDEC) specifications are available from Global Engineering Documents at 800-854-7179 or 303-397-7956.

JEDEC specifications are available on the web at <http://www.jedec.org>.

1. C.E. Triplett and B. Joiner, “An Experimental Characterization of a 272 PBGA Within an Automotive Engine Controller Module,” Proceedings of SemiTherm, San Diego, 1998, pp. 47–54.
2. G. Kromann, S. Shidore, and S. Addison, “Thermal Modeling of a PBGA for Air-Cooled Applications,” Electronic Packaging and Production, pp. 53–58, March 1998.
3. B. Joiner and V. Adams, “Measurement and Simulation of Junction to Board Thermal Resistance and Its Application in Thermal Modeling,” Proceedings of SemiTherm, San Diego, 1999, pp. 212–220.

3.3 Package

The MPC5553 is available in packaged form. Read the package options in [Section 2, “Ordering Information.”](#) Refer to [Section 4, “Mechanicals,”](#) for pinouts and package drawings.

3.4 EMI (Electromagnetic Interference) Characteristics

Table 4. EMI Testing Specifications¹

Spec	Characteristic	Minimum	Typical	Maximum	Unit
1	Scan range	0.15	—	1000	MHz
2	Operating frequency	—	—	f _{MAX}	MHz
3	V _{DD} operating voltages	—	1.5	—	V
4	V _{DDSYN} , V _{RC33} , V _{DD33} , V _{FLASH} , V _{DDE} operating voltages	—	3.3	—	V
5	V _{PP} , V _{DDEH} , V _{DDA} operating voltages	—	5.0	—	V
6	Maximum amplitude	—	—	14 ² 32 ³	dBuV
7	Operating temperature	—	—	25	°C

¹ EMI testing and I/O port waveforms per SAE J1752/3 issued 1995-03. Qualification testing was performed on the MPC5554 and applied to the MPC5500 family as generic EMI performance data.

² Measured with the single-chip EMI program.

³ Measured with the expanded EMI program.

Electrical Characteristics

3.5 ESD (Electromagnetic Static Discharge) Characteristics

Table 5. ESD Ratings^{1, 2}

Characteristic	Symbol	Value	Unit
ESD for human body model (HBM)		2000	V
HBM circuit description	R1	1500	Ω
	C	100	pF
ESD for field induced charge model (FDCM)		500 (all pins)	V
		750 (corner pins)	
Number of pulses per pin:			
Positive pulses (HBM)	—	1	—
Negative pulses (HBM)	—	1	—
Interval of pulses	—	1	second

¹ All ESD testing conforms to CDF-AEC-Q100 Stress Test Qualification for Automotive Grade Integrated Circuits.

² Device failure is defined as: 'If after exposure to ESD pulses, the device does not meet the device specification requirements, which includes the complete DC parametric and functional testing at room temperature and hot temperature.'

3.6 Voltage Regulator Controller (V_{RC}) and Power-On Reset (POR) Electrical Specifications

The following table lists the V_{RC} and POR electrical specifications:

Table 6. V_{RC} and POR Electrical Specifications

Spec	Characteristic		Symbol	Min.	Max.	Units
1	1.5 V (V_{DD}) POR ¹	Negated (ramp up) Asserted (ramp down)	V_{POR15}	1.1 1.1	1.35 1.35	V
2	3.3 V (V_{DDSYN}) POR ¹	Asserted (ramp up) Negated (ramp up) Asserted (ramp down) Negated (ramp down)	V_{POR33}	0.0 2.0 2.0 0.0	0.30 2.85 2.85 0.30	V
3	\overline{RESET} pin supply (V_{DDEH6}) POR ^{1,2}	Negated (ramp up) Asserted (ramp down)	V_{POR5}	2.0 2.0	2.85 2.85	V
4	V_{RC33} voltage	Before V_{RC} allows the pass transistor to start turning on	V_{TRANS_START}	1.0	2.0	V
5		When V_{RC} allows the pass transistor to completely turn on ^{3, 4}	V_{TRANS_ON}	2.0	2.85	V
6		When the voltage is greater than the voltage at which the V_{RC} keeps the 1.5 V supply in regulation ^{5, 6}	$V_{VRC33REG}$	3.0	—	V
7	Current can be sourced by V_{RCCTL} at T_j :	−40° C 25° C 150° C	I_{VRCCTL} ⁷	11.0 9.0 7.5	— — —	mA mA mA
8	Voltage differential during power up such that: V_{DD33} can lag V_{DDSYN} or V_{DDEH6} before V_{DDSYN} and V_{DDEH6} reach the V_{POR33} and V_{POR5} minimums respectively.		V_{DD33_LAG}	—	1.0	V

Table 6. V_{RC} and POR Electrical Specifications (continued)

Spec	Characteristic		Symbol	Min.	Max.	Units
9	Absolute value of slew rate on power supply pins		—	—	50	V/ms
10	Required gain at Tj:	– 40° C	BETA ¹⁰	40	—	—
	$I_{DD} \div I_{VRCCTL}$ (@ $f_{sys} = f_{MAX}$)	25° C		45	—	—
	6, 7, 8, 9	150° C		55	500	—

¹ The internal POR signals are V_{POR15} , V_{POR33} , and V_{POR5} . On power up, assert \overline{RESET} before the internal POR negates. \overline{RESET} must remain asserted until the power supplies are within the operating conditions as specified in Table 9 DC Electrical Specifications. On power down, assert \overline{RESET} before any power supplies fall outside the operating conditions and until the internal POR asserts.

² V_{IL_S} (Table 9, Spec15) is guaranteed to scale with V_{DDEH6} down to V_{POR5} .

³ Supply full operating current for the 1.5 V supply when the 3.3 V supply reaches this range.

⁴ It is possible to reach the current limit during ramp up—do not treat this event as short circuit current.

⁵ At peak current for device.

⁶ Requires compliance with Freescale's recommended board requirements and transistor recommendations. Board signal traces/routing from the V_{RCCTL} package signal to the base of the external pass transistor and between the emitter of the pass transistor to the V_{DD} package signals must have a maximum of 100 nH inductance and minimal resistance (less than 1 Ω). V_{RCCTL} must have a nominal 1 μ F phase compensation capacitor to ground. V_{DD} must have a 20 μ F (nominal) bulk capacitor (greater than 4 μ F over all conditions, including lifetime). Place high-frequency bypass capacitors consisting of eight 0.01 μ F, two 0.1 μ F, and one 1 μ F capacitors around the package on the V_{DD} supply signals.

⁷ I_{VRCCTL} is measured at the following conditions: $V_{DD} = 1.35$ V, $V_{RC33} = 3.1$ V, $V_{VRCCTL} = 2.2$ V.

⁸ Refer to Table 1 for the maximum operating frequency.

⁹ Values are based on I_{DD} from high-use applications as explained in the I_{DD} Electrical Specification.

¹⁰ BETA is the worst-case external transistor BETA. It is measured on a per-part basis and calculated as $(I_{DD} \div I_{VRCCTL})$.

3.7 Power-Up/Down Sequencing

Power sequencing between the 1.5 V power supply and V_{DDSYN} or the \overline{RESET} power supplies is required if using an external 1.5 V power supply with V_{RC33} tied to ground (GND). To avoid power-sequencing, V_{RC33} must be powered up within the specified operating range, even if the on-chip voltage regulator controller is not used. Refer to Section 3.7.2, “Power-Up Sequence (VRC33 Grounded),” and Section 3.7.3, “Power-Down Sequence (VRC33 Grounded).”

Power sequencing requires that V_{DD33} must reach a certain voltage where the values are read as ones before the POR signal negates. Refer to Section 3.7.1, “Input Value of Pins During POR Dependent on VDD33.”

Although power sequencing is not required between V_{RC33} and V_{DDSYN} during power up, V_{RC33} must not lead V_{DDSYN} by more than 600 mV or lag by more than 100 mV for the V_{RC} stage turn-on to operate within specification. Higher spikes in the emitter current of the pass transistor occur if V_{RC33} leads or lags V_{DDSYN} by more than these amounts. The value of that higher spike in current depends on the board power supply circuitry and the amount of board level capacitance.

Furthermore, when all of the PORs negate, the system clock starts to toggle, adding another large increase of the current consumed by V_{RC33} . If V_{RC33} lags V_{DDSYN} by more than 100 mV, the increase in current consumed can drop V_{DD} low enough to assert the 1.5 V POR again. Oscillations are possible when the 1.5 V POR asserts and stops the system clock, causing the voltage on V_{DD} to rise until the 1.5 V POR negates again. All oscillations stop when V_{RC33} is powered sufficiently.

Electrical Characteristics

When powering down, V_{RC33} and V_{DDSYN} have no delta requirement to each other, because the bypass capacitors internal and external to the device are already charged. When not powering up or down, no delta between V_{RC33} and V_{DDSYN} is required for the V_{RC} to operate within specification.

There are no power up/down sequencing requirements to prevent issues such as latch-up, excessive current spikes, and so on. Therefore, the state of the I/O pins during power up and power down varies depending on which supplies are powered.

Table 7 gives the pin state for the sequence cases for all pins with pad type pad_fc (fast type).

Table 7. Pin Status for Fast Pads During the Power Sequence

V_{DDE}	V_{DD33}	V_{DD}	POR	Pin Status for Fast Pad Output Driver pad_fc (fast)
Low	—	—	Asserted	Low
V_{DDE}	Low	Low	Asserted	High
V_{DDE}	Low	V_{DD}	Asserted	High
V_{DDE}	V_{DD33}	Low	Asserted	High impedance (Hi-Z)
V_{DDE}	V_{DD33}	V_{DD}	Asserted	Hi-Z
V_{DDE}	V_{DD33}	V_{DD}	Negated	Functional

Table 8 gives the pin state for the sequence cases for all pins with pad type pad_mh (medium type) and pad_sh (slow type).

Table 8. Pin Status for Medium and Slow Pads During the Power Sequence

V_{DDEH}	V_{DD}	POR	Pin Status for Medium and Slow Pad Output Driver pad_mh (medium) pad_sh (slow)
Low	—	Asserted	Low
V_{DDEH}	Low	Asserted	High impedance (Hi-Z)
V_{DDEH}	V_{DD}	Asserted	Hi-Z
V_{DDEH}	V_{DD}	Negated	Functional

The values in Table 7 and Table 8 do not include the effect of the weak-pull devices on the output pins during power up.

Before exiting the internal POR state, the voltage on the pins go to a high-impedance state until POR negates. When the internal POR negates, the functional state of the signal during reset applies and the weak-pull devices

(up or down) are enabled as defined in the device reference manual. If V_{DD} is too low to correctly propagate the logic signals, the weak-pull devices can pull the signals to V_{DDE} and V_{DDEH} .

To avoid this condition, minimize the ramp time of the V_{DD} supply to a time period less than the time required to enable the external circuitry connected to the device outputs.

During initial power ramp-up, when V_{stby} is 0.6v or above. a typical current of 1-3mA and maximum of 4mA may be seen until V_{DD} is applied. This current will not reoccur until V_{stby} is lowered below V_{stby} min. specification.

Figure 2 shows an approximate interpolation of the I_{STBY} worst-case specification to estimate values at different voltages and temperatures. The vertical lines shown at 25 °C, 60 °C, and 150 °C in Figure 2 are the actual I_{DD_STBY} specifications (27d) listed in Table 9.

Figure 2. I_{STBY} Worst-case Specifications

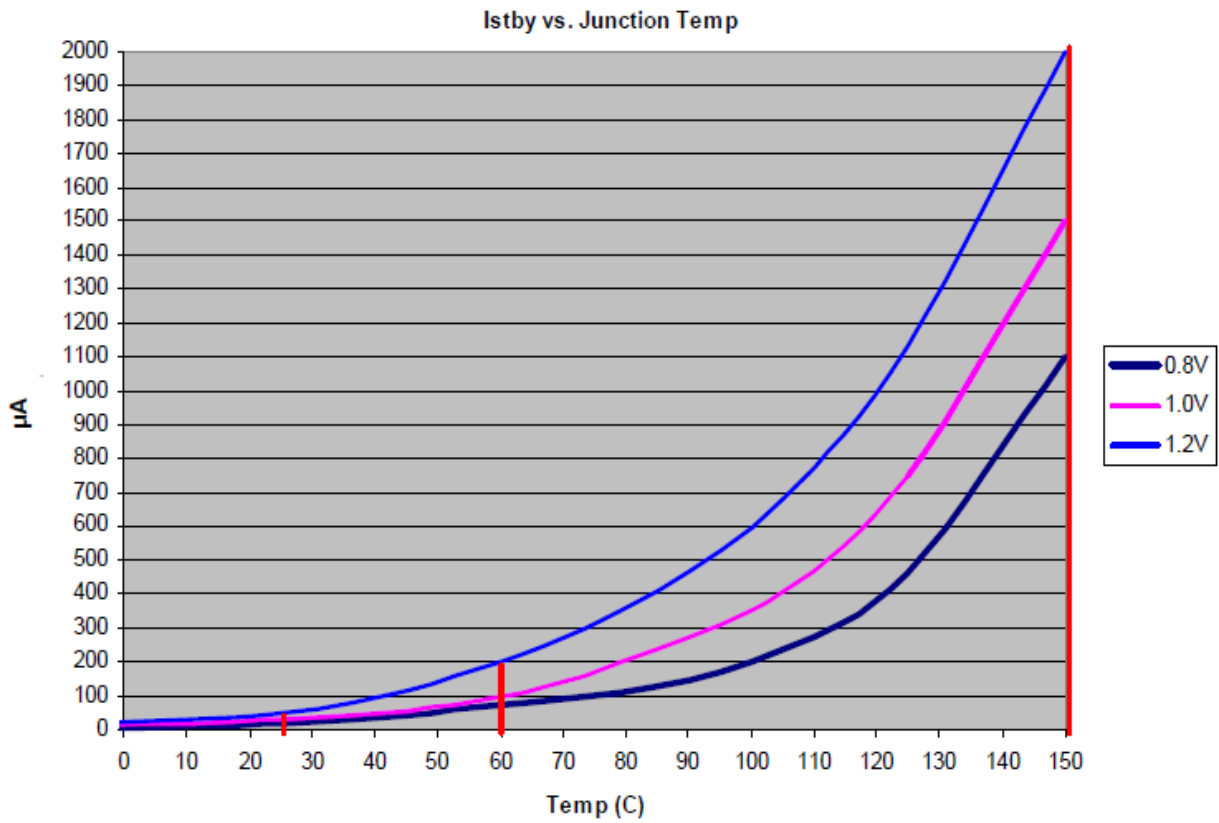

Electrical Characteristics

3.7.1 Input Value of Pins During POR Dependent on V_{DD33}

When powering up the device, V_{DD33} must not lag the latest V_{DDSYN} or $\overline{\text{RESET}}$ power pin (V_{DDEH6}) by more than the V_{DD33} lag specification listed in Table 6, spec 8. This avoids accidentally selecting the bypass clock mode because the internal versions of PLLCFG[0:1] and $\overline{\text{RSTCFG}}$ are not powered and therefore cannot read the default state when POR negates. V_{DD33} can lag V_{DDSYN} or the $\overline{\text{RESET}}$ power pin (V_{DDEH6}), but cannot lag both by more than the V_{DD33} lag specification. This V_{DD33} lag specification applies during power up only. V_{DD33} has no lead or lag requirements when powering down.

3.7.2 Power-Up Sequence (V_{RC33} Grounded)

The 1.5 V V_{DD} power supply must rise to 1.35 V before the 3.3 V V_{DDSYN} power supply and the $\overline{\text{RESET}}$ power supply rises above 2.0 V. This ensures that digital logic in the PLL for the 1.5 V power supply does not begin to operate below the specified operation range lower limit of 1.35 V. Because the internal 1.5 V POR is disabled, the internal 3.3 V POR or the $\overline{\text{RESET}}$ power POR must hold the device in reset. Since they can negate as low as 2.0 V, V_{DD} must be within specification before the 3.3 V POR and the $\overline{\text{RESET}}$ POR negate.

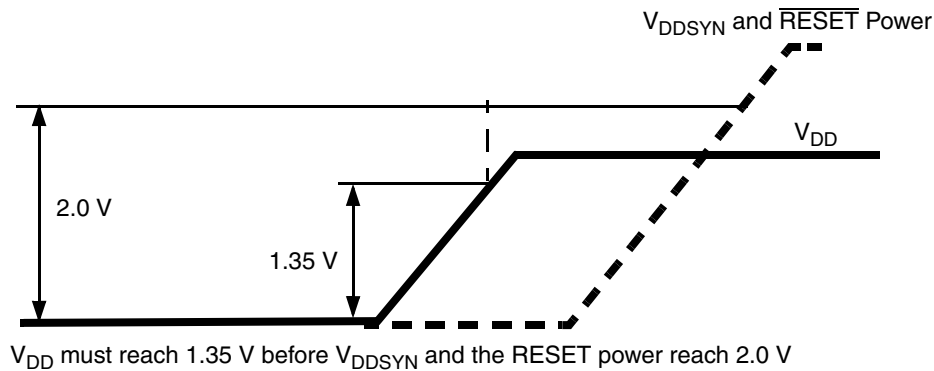

Figure 3. Power-Up Sequence (V_{RC33} Grounded)

3.7.3 Power-Down Sequence (V_{RC33} Grounded)

The only requirement for the power-down sequence with V_{RC33} grounded is if V_{DD} decreases to less than its operating range, V_{DDSYN} or the $\overline{\text{RESET}}$ power must decrease to less than 2.0 V before the V_{DD} power increases to its operating range. This ensures that the digital 1.5 V logic, which is reset only by an ORed POR and can cause the 1.5 V supply to decrease less than its specification value, resets correctly. See Table 6, footnote 1.

3.8 DC Electrical Specifications

Table 9. DC Electrical Specifications ($T_A = T_L$ to T_H)

Spec	Characteristic	Symbol	Min	Max.	Unit
1	Core supply voltage (average DC RMS voltage)	V_{DD}	1.35	1.65	V
2	Input/output supply voltage (fast input/output) ¹	V_{DDE}	1.62	3.6	V
3	Input/output supply voltage (slow and medium input/output)	V_{DDEH}	3.0	5.25	V
4	3.3 V input/output buffer voltage	V_{DD33}	3.0	3.6	V
5	Voltage regulator control input voltage	V_{RC33}	3.0	3.6	V
6	Analog supply voltage ²	V_{DDA}	4.5	5.25	V
8	Flash programming voltage ³	V_{PP}	4.5	5.25	V
9	Flash read voltage	V_{FLASH}	3.0	3.6	V
10	SRAM standby voltage ⁴	V_{STBY}	0.8	1.2	V
11	Clock synthesizer operating voltage	V_{DDSYN}	3.0	3.6	V
12	Fast I/O input high voltage	V_{IH_F}	$0.65 \times V_{DDE}$	$V_{DDE} + 0.3$	V
13	Fast I/O input low voltage	V_{IL_F}	$V_{SS} - 0.3$	$0.35 \times V_{DDE}$	V
14	Medium and slow I/O input high voltage	V_{IH_S}	$0.65 \times V_{DDEH}$	$V_{DDEH} + 0.3$	V
15	Medium and slow I/O input low voltage	V_{IL_S}	$V_{SS} - 0.3$	$0.35 \times V_{DDEH}$	V
16	Fast input hysteresis	V_{HYS_F}	$0.1 \times V_{DDE}$		V
17	Medium and slow I/O input hysteresis	V_{HYS_S}	$0.1 \times V_{DDEH}$		V
18	Analog input voltage	V_{INDC}	$V_{SSA} - 0.3$	$V_{DDA} + 0.3$	V
19	Fast output high voltage ($I_{OH_F} = -2.0$ mA)	V_{OH_F}	$0.8 \times V_{DDE}$	—	V
20	Slow and medium output high voltage $I_{OH_S} = -2.0$ mA $I_{OH_S} = -1.0$ mA	V_{OH_S}	$0.80 \times V_{DDEH}$ $0.85 \times V_{DDEH}$	—	V
21	Fast output low voltage ($I_{OL_F} = 2.0$ mA)	V_{OL_F}	—	$0.2 \times V_{DDE}$	V
22	Slow and medium output low voltage $I_{OL_S} = 2.0$ mA $I_{OL_S} = 1.0$ mA	V_{OL_S}	—	$0.20 \times V_{DDEH}$ $0.15 \times V_{DDEH}$	V
23	Load capacitance (fast I/O) ⁵ DSC (SIU_PCR[8:9]) = 0b00 = 0b01 = 0b10 = 0b11	C_L	— — — —	10 20 30 50	pF pF pF pF
24	Input capacitance (digital pins)	C_{IN}	—	7	pF
25	Input capacitance (analog pins)	C_{IN_A}	—	10	pF
26	Input capacitance: (Shared digital and analog pins AN[12]_MA[0]_SDS, AN[13]_MA[1]_SDO, AN[14]_MA[2]_SDI, and AN[15]_FCK)	C_{IN_M}	—	12	pF

Electrical Characteristics
Table 9. DC Electrical Specifications ($T_A = T_L$ to T_H) (continued)

Spec	Characteristic	Symbol	Min	Max.	Unit
27a	Operating current 1.5 V supplies @ 132 MHz: ⁶				
	V_{DD} (including V_{DDF} max current) @ 1.65 V typical use ^{7, 8}	I_{DD}	—	460	mA
	V_{DD} (including V_{DDF} max current) @ 1.35 V typical use ^{7, 8}	I_{DD}	—	360	mA
	V_{DD} (including V_{DDF} max current) @ 1.65 V high use ^{8, 9}	I_{DD}	—	510	mA
27b	Operating current 1.5 V supplies @ 114 MHz: ⁶				
	V_{DD} (including V_{DDF} max current) @ 1.65 V typical use ^{7, 8}	I_{DD}	—	410	mA
	V_{DD} (including V_{DDF} max current) @ 1.35 V typical use ^{7, 8}	I_{DD}	—	310	mA
	V_{DD} (including V_{DDF} max current) @ 1.65 V high use ^{8, 9}	I_{DD}	—	460	mA
27c	Operating current 1.5 V supplies @ 82 MHz: ⁶				
	V_{DD} (including V_{DDF} max current) @ 1.65 V typical use ^{7, 8}	I_{DD}	—	330	mA
	V_{DD} (including V_{DDF} max current) @ 1.35 V typical use ^{7, 8}	I_{DD}	—	225	mA
	V_{DD} (including V_{DDF} max current) @ 1.65 V high use ^{8, 9}	I_{DD}	—	385	mA
27d	RAM standby current. ¹⁰				
	I_{DD_STBY} @ 25° C				
	V_{STBY} @ 0.8 V	I_{DD_STBY}	—	20	μA
	V_{STBY} @ 1.0 V	I_{DD_STBY}	—	30	μA
	V_{STBY} @ 1.2 V	I_{DD_STBY}	—	50	μA
	I_{DD_STBY} @ 60° C				
	V_{STBY} @ 0.8 V	I_{DD_STBY}	—	70	μA
	V_{STBY} @ 1.0 V	I_{DD_STBY}	—	100	μA
	V_{STBY} @ 1.2 V	I_{DD_STBY}	—	200	μA
	I_{DD_STBY} @ 150° C (Tj)				
	V_{STBY} @ 0.8 V	I_{DD_STBY}	—	1200	μA
	V_{STBY} @ 1.0 V	I_{DD_STBY}	—	1500	μA
V_{STBY} @ 1.2 V	I_{DD_STBY}	—	2000	μA	
28	Operating current 3.3 V supplies @ f_{MAX} MHz				
	V_{DD33} ¹¹	I_{DD_33}	—	2 + (values derived from procedure of footnote ¹¹)	mA
	V_{FLASH}	I_{VFLASH}	—	10	mA
	V_{DDSYN}	I_{DDSYN}	—	15	mA
29	Operating current 5.0 V supplies (12 MHz ADCLK):				
	V_{DDA} ($V_{DDA0} + V_{DDA1}$)	I_{DD_A}	—	20.0	mA
	Analog reference supply current (V_{RH} , V_{RL})	I_{REF}	—	1.0	mA
	V_{PP}	I_{PP}	—	25.0	mA

Table 9. DC Electrical Specifications ($T_A = T_L$ to T_H) (continued)

Spec	Characteristic	Symbol	Min	Max.	Unit
30	Operating current V_{DDE} supplies: ¹²				
	V_{DDEH1}	I_{DD1}	—	Refer to footnote ¹²	mA
	V_{DDE2}	I_{DD2}	—		mA
	V_{DDE3}	I_{DD3}	—		mA
	V_{DDEH4}	I_{DD4}	—		mA
	V_{DDE5}	I_{DD5}	—		mA
	V_{DDEH6}	I_{DD6}	—		mA
	V_{DDE7}	I_{DD7}	—		mA
	V_{DDEH8}	I_{DD8}	—		mA
V_{DDEH9}	I_{DD9}	—	mA		
31	Fast I/O weak pullup current ¹³ 1.62–1.98 V 2.25–2.75 V 3.00–3.60 V	I_{ACT_F}	10 20 20	110 130 170	μ A μ A μ A
	Fast I/O weak pulldown current ¹³ 1.62–1.98 V 2.25–2.75 V 3.00–3.60 V		10 20 20	100 130 170	μ A μ A μ A
32	Slow and medium I/O weak pullup/down current ¹³ 3.0–3.6 V 4.5–5.5 V	I_{ACT_S}	10 20	150 170	μ A μ A
33	I/O input leakage current ¹⁴	I_{INACT_D}	–2.5	2.5	μ A
34	DC injection current (per pin)	I_{IC}	–2.0	2.0	mA
35	Analog input current, channel off ¹⁵	I_{INACT_A}	–150	150	nA
35a	Analog input current, shared analog / digital pins (AN[12], AN[13], AN[14], AN[15])	I_{INACT_AD}	–2.5	2.5	μ A
36	V_{SS} to V_{SSA} differential voltage ¹⁶	$V_{SS} - V_{SSA}$	–100	100	mV
37	Analog reference low voltage	V_{RL}	$V_{SSA} - 0.1$	$V_{SSA} + 0.1$	V
38	V_{RL} differential voltage	$V_{RL} - V_{SSA}$	–100	100	mV
39	Analog reference high voltage	V_{RH}	$V_{DDA} - 0.1$	$V_{DDA} + 0.1$	V
40	V_{REF} differential voltage	$V_{RH} - V_{RL}$	4.5	5.25	V
41	V_{SSSYN} to V_{SS} differential voltage	$V_{SSSYN} - V_{SS}$	–50	50	mV
42	V_{RCVSS} to V_{SS} differential voltage	$V_{RCVSS} - V_{SS}$	–50	50	mV
43	V_{DDF} to V_{DD} differential voltage	$V_{DDF} - V_{DD}$	–100	100	mV
43a	V_{RC33} to V_{DDSYN} differential voltage	$V_{RC33} - V_{DDSYN}$	–0.1	0.1 ¹⁷	V
44	Analog input differential signal range (with common mode 2.5 V)	V_{IDIFF}	–2.5	2.5	V
45	Operating temperature range, ambient (packaged)	$T_A = (T_L \text{ to } T_H)$	T_L	T_H	°C
46	Slew rate on power-supply pins	—	—	50	V/ms

¹ V_{DDE2} and V_{DDE3} are limited to 2.25–3.6 V only if SIU_ECCR[EBTS] = 0; V_{DDE2} and V_{DDE3} have a range of 1.6–3.6 V if SIU_ECCR[EBTS] = 1.

Electrical Characteristics

- ² $|V_{DDA0} - V_{DDA1}|$ must be < 0.1 V.
- ³ V_{PP} can drop to 3.0 V during read operations.
- ⁴ If standby operation is not required, connect V_{STBY} to ground.
- ⁵ Applies to CLKOUT, external bus pins, and Nexus pins.
- ⁶ Maximum average RMS DC current.
- ⁷ Average current measured on Automotive benchmark.
- ⁸ Peak currents can be higher on specialized code.
- ⁹ High use current measured while running optimized SPE assembly code with all code and data 100% locked in cache (0% miss rate) with all channels of the eMIOS and eTPU running autonomously, plus the eDMA transferring data continuously from SRAM to SRAM. Higher currents are possible if an idle loop that crosses cache lines is run from cache. Design and write code to avoid this condition.
- ¹⁰ The current specification relates to average standby operation after SRAM has been loaded with data. For power up current see [Section 3.7, "Power-Up/Down Sequencing"](#), [Figure 2](#).
- ¹¹ Power requirements for the V_{DD33} supply depend on the frequency of operation, load of all I/O pins, and the voltages on the I/O segments. Refer to [Table 11](#) for values to calculate the power dissipation for a specific operation.
- ¹² Power requirements for each I/O segment are dependent on the frequency of operation and load of the I/O pins on a particular I/O segment, and the voltage of the I/O segment. Refer to [Table 10](#) for values to calculate power dissipation for specific operation. The total power consumption of an I/O segment is the sum of the individual power consumptions for each pin on the segment.
- ¹³ Absolute value of current, measured at V_{IL} and V_{IH} .
- ¹⁴ Weak pullup/down inactive. Measured at $V_{DDE} = 3.6$ V and $V_{DDEH} = 5.25$ V. Applies to pad types: pad_fc, pad_sh, and pad_mh.
- ¹⁵ Maximum leakage occurs at maximum operating temperature. Leakage current decreases by approximately one-half for each 8 °C to 12 °C, in the ambient temperature range of 50 °C to 125 °C. Applies to pad types: pad_a and pad_ae.
- ¹⁶ V_{SSA} refers to both V_{SSA0} and V_{SSA1} . $|V_{SSA0} - V_{SSA1}|$ must be < 0.1 V.
- ¹⁷ Up to 0.6 V during power up and power down.

3.8.1 I/O Pad Current Specifications

The power consumption of an I/O segment depends on the usage of the pins on a particular segment. The power consumption is the sum of all output pin currents for a segment. The output pin current can be calculated from [Table 10](#) based on the voltage, frequency, and load on the pin. Use linear scaling to calculate pin currents for voltage, frequency, and load parameters that fall outside the values given in [Table 10](#).

Table 10. I/O Pad Average DC Current ($T_A = T_L$ to T_H)¹

Spec	Pad Type	Symbol	Frequency (MHz)	Load ² (pF)	Voltage (V)	Drive Select / Slew Rate Control Setting	Current (mA)
1	Slow	I_{DRV_SH}	25	50	5.25	11	8.0
2			10	50	5.25	01	3.2
3			2	50	5.25	00	0.7
4			2	200	5.25	00	2.4
5	Medium	I_{DRV_MH}	50	50	5.25	11	17.3
6			20	50	5.25	01	6.5
7			3.33	50	5.25	00	1.1
8			3.33	200	5.25	00	3.9
9	Fast	I_{DRV_FC}	66	10	3.6	00	2.8
10			66	20	3.6	01	5.2
11			66	30	3.6	10	8.5
12			66	50	3.6	11	11.0
13			66	10	1.98	00	1.6
14			66	20	1.98	01	2.9
15			66	30	1.98	10	4.2
16			66	50	1.98	11	6.7
17			56	10	3.6	00	2.4
18			56	20	3.6	01	4.4
19			56	30	3.6	10	7.2
20			56	50	3.6	11	9.3
21			56	10	1.98	00	1.3
22			56	20	1.98	01	2.5
23			56	30	1.98	10	3.5
24			56	50	1.98	11	5.7
25			40	10	3.6	00	1.7
26			40	20	3.6	01	3.1
27			40	30	3.6	10	5.1
28			40	50	3.6	11	6.6
29			40	10	1.98	00	1.0
30			40	20	1.98	01	1.8
31			40	30	1.98	10	2.5
32			40	50	1.98	11	4.0

¹ These values are estimates from simulation and are not tested. Currents apply to output pins only.

² All loads are lumped.

Electrical Characteristics
3.8.2 I/O Pad V_{DD33} Current Specifications

The power consumption of the V_{DD33} supply depends on the usage of the pins on all I/O segments. The power consumption is the sum of all input and output pin V_{DD33} currents for all I/O segments. The output pin V_{DD33} current can be calculated from Table 11 based on the voltage, frequency, and load on all fast (pad_fc) pins. The input pin V_{DD33} current can be calculated from Table 11 based on the voltage, frequency, and load on all pad_sh and pad_mh pins. Use linear scaling to calculate pin currents for voltage, frequency, and load parameters that fall outside the values given in Table 11.

Table 11. V_{DD33} Pad Average DC Current ($T_A = T_L$ to T_H)¹

Spec	Pad Type	Symbol	Frequency (MHz)	Load ² (pF)	V_{DD33} (V)	V_{DDE} (V)	Drive Select	Current (mA)
Inputs								
1	Slow	I_{33_SH}	66	0.5	3.6	5.5	NA	0.003
2	Medium	I_{33_MH}	66	0.5	3.6	5.5	NA	0.003
Outputs								
3	Fast	I_{33_FC}	66	10	3.6	3.6	00	0.35
4			66	20	3.6	3.6	01	0.53
5			66	30	3.6	3.6	10	0.62
6			66	50	3.6	3.6	11	0.79
7			66	10	3.6	1.98	00	0.35
8			66	20	3.6	1.98	01	0.44
9			66	30	3.6	1.98	10	0.53
10			66	50	3.6	1.98	11	0.70
11			56	10	3.6	3.6	00	0.30
12			56	20	3.6	3.6	01	0.45
13			56	30	3.6	3.6	10	0.52
14			56	50	3.6	3.6	11	0.67
15			56	10	3.6	1.98	00	0.30
16			56	20	3.6	1.98	01	0.37
17			56	30	3.6	1.98	10	0.45
18			56	50	3.6	1.98	11	0.60
19			40	10	3.6	3.6	00	0.21
20			40	20	3.6	3.6	01	0.31
21			40	30	3.6	3.6	10	0.37
22			40	50	3.6	3.6	11	0.48
23			40	10	3.6	1.98	00	0.21
24			40	20	3.6	1.98	01	0.27
25			40	30	3.6	1.98	10	0.32
26			40	50	3.6	1.98	11	0.42

¹ These values are estimated from simulation and not tested. Currents apply to output pins for the fast pads only and to input pins for the slow and medium pads only.

² All loads are lumped.

3.9 Oscillator and FMPLL Electrical Characteristics

Table 12. FMPLL Electrical Specifications
 ($V_{DDSYN} = 3.0\text{--}3.6\text{ V}$; $V_{SS} = V_{SSSYN} = 0.0\text{ V}$; $T_A = T_L$ to T_H)

Spec	Characteristic	Symbol	Minimum	Maximum	Unit
1	PLL reference frequency range: ¹ Crystal reference External reference Dual controller (1:1 mode)	$f_{ref_crystal}$ f_{ref_ext} $f_{ref_1:1}$	8 8 24	20 20 $f_{sys} \div 2$	MHz
2	System frequency ²	f_{sys}	$f_{ICO(MIN)} \div 2^{RFD}$	f_{MAX} ³	MHz
3	System clock period	t_{CYC}	—	$1 \div f_{sys}$	ns
4	Loss of reference frequency ⁴	f_{LOR}	100	1000	kHz
5	Self-clocked mode (SCM) frequency ⁵	f_{SCM}	7.4	17.5	MHz
6	EXTAL input high voltage crystal mode ⁶ All other modes [dual controller (1:1), bypass, external reference]	V_{IHEXT}	$V_{XTAL} + 0.4\text{ V}$	—	V
		V_{IHEXT}	$(V_{DDE5} \div 2) + 0.4\text{ V}$	—	V
7	EXTAL input low voltage crystal mode ⁷ All other modes [dual controller (1:1), bypass, external reference]	V_{ILEXT}	—	$V_{XTAL} - 0.4\text{ V}$	V
		V_{ILEXT}	—	$(V_{DDE5} \div 2) - 0.4\text{ V}$	V
8	XTAL current ⁸	I_{XTAL}	0.8	3	mA
9	Total on-chip stray capacitance on XTAL	C_{S_XTAL}	—	1.5	pF
10	Total on-chip stray capacitance on EXTAL	C_{S_EXTAL}	—	1.5	pF
11	Crystal manufacturer's recommended capacitive load	C_L	Refer to crystal specification	Refer to crystal specification	pF
12	Discrete load capacitance to connect to EXTAL	C_{L_EXTAL}	—	$(2 \times C_L) - C_{S_EXTAL} - C_{PCB_EXTAL}$ ⁹	pF
13	Discrete load capacitance to connect to XTAL	C_{L_XTAL}	—	$(2 \times C_L) - C_{S_XTAL} - C_{PCB_XTAL}$ ⁹	pF
14	PLL lock time ¹⁰	t_{pll}	—	750	μs
15	Dual controller (1:1) clock skew (between CLKOUT and EXTAL) ^{11, 12}	t_{skew}	-2	2	ns
16	Duty cycle of reference	t_{DC}	40	60	%
17	Frequency unLOCK range	f_{UL}	-4.0	4.0	% f_{sys}
18	Frequency LOCK range	f_{LCK}	-2.0	2.0	% f_{sys}

Electrical Characteristics
Table 12. FMPLL Electrical Specifications (continued)
 $(V_{DDSYN} = 3.0\text{--}3.6\text{ V}; V_{SS} = V_{SSSYN} = 0.0\text{ V}; T_A = T_L \text{ to } T_H)$

Spec	Characteristic	Symbol	Minimum	Maximum	Unit
19	CLKOUT period jitter, measured at f_{SYS} max: ^{13, 14} Peak-to-peak jitter (clock edge to clock edge) Long term jitter (averaged over a 2 ms interval)	C_{JITTER}	— —	5.0 0.01	% f_{CLKOUT}
20	Frequency modulation range limit ¹⁵ (do not exceed f_{SYS} maximum)	C_{MOD}	0.8	2.4	% f_{SYS}
21	ICO frequency $f_{ICO} = [f_{ref_crystal} \times (MFD + 4)] \div (PREDIV + 1)$ ¹⁶ $f_{ICO} = [f_{ref_ext} \times (MFD + 4)] \div (PREDIV + 1)$	f_{ICO}	48	f_{MAX}	MHz
22	Predivider output frequency (to PLL)	f_{PREDIV}	4	20 ¹⁷	MHz

¹ Nominal crystal and external reference values are worst-case not more than 1%. The device operates correctly if the frequency remains within $\pm 5\%$ of the specification limit. This tolerance range allows for a slight frequency drift of the crystals over time. The designer must thoroughly understand the drift margin of the source clock.

² All internal registers retain data at 0 Hz.

³ Up to the maximum frequency rating of the device (refer to [Table 1](#)).

⁴ Loss of reference frequency is defined as the reference frequency detected internally, which transitions the PLL into self-clocked mode.

⁵ The PLL operates at self-clocked mode (SCM) frequency when the reference frequency falls below f_{LOR} . SCM frequency is measured on the CLKOUT ball with the divider set to divide-by-two of the system clock.
NOTE: In SCM, the MFD and PREDIV have no effect and the RFD is bypassed.

⁶ Use the EXTAL input high voltage parameter when using the FlexCAN oscillator in crystal mode (no quartz crystals or resonators). $(V_{extal} - V_{xtal})$ must be ≥ 400 mV for the oscillator's comparator to produce the output clock.

⁷ Use the EXTAL input low voltage parameter when using the FlexCAN oscillator in crystal mode (no quartz crystals or resonators). $(V_{xtal} - V_{extal})$ must be ≥ 400 mV for the oscillator's comparator to produce the output clock.

⁸ I_{xtal} is the oscillator bias current out of the XTAL pin with both EXTAL and XTAL pins grounded.

⁹ C_{PCB_EXTAL} and C_{PCB_XTAL} are the measured PCB stray capacitances on EXTAL and XTAL, respectively.

¹⁰ This specification applies to the period required for the PLL to relock after changing the MFD frequency control bits in the synthesizer control register (SYNCR). From power up with crystal oscillator reference, the lock time also includes the crystal startup time.

¹¹ PLL is operating in 1:1 PLL mode.

¹² $V_{DDE} = 3.0\text{--}3.6\text{ V}$.

¹³ Jitter is the average deviation from the programmed frequency measured over the specified interval at maximum f_{SYS} . Measurements are made with the device powered by filtered supplies and clocked by a stable external clock signal. Noise injected into the PLL circuitry via V_{DDSYN} and V_{SSSYN} and variation in crystal oscillator frequency increase the jitter percentage for a given interval. CLKOUT divider is set to divide-by-two.

¹⁴ Values are with frequency modulation disabled. If frequency modulation is enabled, jitter is the sum of (jitter + Cmod).

¹⁵ Modulation depth selected must not result in f_{SYS} value greater than the f_{SYS} maximum specified value.

¹⁶ $f_{SYS} = f_{ICO} \div (2^{RFD})$.

¹⁷ Maximum value for dual controller (1:1) mode is $(f_{MAX} \div 2)$ with the predivider set to 1 (FMPLL_SYNCR[PREDIV] = 0b001).

3.10 eQADC Electrical Characteristics

Table 13. eQADC Conversion Specifications ($T_A = T_L$ to T_H)

Spec	Characteristic	Symbol	Minimum	Maximum	Unit
1	ADC clock (ADCLK) frequency ¹	F_{ADCLK}	1	12	MHz
2	Conversion cycles Differential Single ended	CC	13 + 2 (15) 14 + 2 (16)	13 + 128 (141) 14 + 128 (142)	ADCLK cycles
3	Stop mode recovery time ²	T_{SR}	10	—	μ s
4	Resolution ³	—	1.25	—	mV
5	INL: 6 MHz ADC clock	INL6	-4	4	Counts ³
6	INL: 12 MHz ADC clock	INL12	-8	8	Counts
7	DNL: 6 MHz ADC clock	DNL6	-3 ⁴	3 ⁴	Counts
8	DNL: 12 MHz ADC clock	DNL12	-6 ⁴	6 ⁴	Counts
9	Offset error with calibration	OFFWC	-4 ⁵	4 ⁵	Counts
10	Full-scale gain error with calibration	GAINWC	-8 ⁶	8 ⁶	Counts
11	Disruptive input injection current ^{7, 8, 9, 10}	I_{INJ}	-1	1	mA
12	Incremental error due to injection current. All channels are $10\text{ k}\Omega < R_s < 100\text{ k}\Omega$ Channel under test has $R_s = 10\text{ k}\Omega$, $I_{INJ} = I_{INJMAX}, I_{INJMIN}$	E_{INJ}	-4	4	Counts
13	Total unadjusted error (TUE) for single ended conversions with calibration ^{11, 12, 13, 14, 15}	TUE	-4	4	Counts

¹ Conversion characteristics vary with F_{ADCLK} rate. Reduced conversion accuracy occurs at maximum F_{ADCLK} rate. The maximum value is based on 800 KS/s and the minimum value is based on 20 MHz oscillator clock frequency divided by a maximum 16 factor.

² Stop mode recovery time begins when the ADC control register enable bits are set until the ADC is ready to perform conversions.

³ At $V_{RH} - V_{RL} = 5.12\text{ V}$, one least significant bit (LSB) = 1.25, mV = one count.

⁴ Guaranteed 10-bit mono tonicity.

⁵ The absolute value of the offset error without calibration ≤ 100 counts.

⁶ The absolute value of the full scale gain error without calibration ≤ 120 counts.

⁷ Below disruptive current conditions, the channel being stressed has conversion values of: 0x3FF for analog inputs greater than V_{RH} , and 0x000 for values less than V_{RL} . This assumes that $V_{RH} \leq V_{DDA}$ and $V_{RL} \geq V_{SSA}$ due to the presence of the sample amplifier. Other channels are not affected by non-disruptive conditions.

⁸ Exceeding the limit can cause a conversion error on both stressed and unstressed channels. Transitions within the limit do not affect device reliability or cause permanent damage.

⁹ Input must be current limited to the value specified. To determine the value of the required current-limiting resistor, calculate resistance values using $V_{POSCLAMP} = V_{DDA} + 0.5\text{ V}$ and $V_{NEGCLAMP} = -0.3\text{ V}$, then use the larger of the calculated values.

¹⁰ This condition applies to two adjacent pads on the internal pad.

¹¹ The TUE specification is always less than the sum of the INL, DNL, offset, and gain errors due to canceling errors.

¹² TUE does not apply to differential conversions.

¹³ Measured at 6 MHz ADC clock. TUE with a 12 MHz ADC clock is: $-16\text{ counts} < \text{TUE} < 16\text{ counts}$.

¹⁴ TUE includes all internal device errors such as internal reference variation (75% Ref, 25% Ref).

¹⁵ Depending on the input impedance, the analog input leakage current (Table 9. DC Electrical Specifications, spec 35a) can affect the actual TUE measured on analog channels AN[12], AN[13], AN[14], AN[15].

Electrical Characteristics

3.11 H7Fa Flash Memory Electrical Characteristics

Table 14. Flash Program and Erase Specifications ($T_A = T_L$ to T_H)

Spec	Flash Program Characteristic	Symbol	Min.	Typical ¹	Initial Max. ²	Max. ³	Unit
3	Doubleword (64 bits) program time ⁴	$T_{dwprogram}$	—	10	—	500	μ s
4	Page program time ⁴	$T_{pprogram}$	—	22	44 ⁵	500	μ s
7	16 KB block pre-program and erase time	$T_{16kpperase}$	—	265	400	5000	ms
9	48 KB block pre-program and erase time	$T_{48kpperase}$	—	345	400	5000	ms
10	64 KB block pre-program and erase time	$T_{64kpperase}$	—	415	500	5000	ms
8	128 KB block pre-program and erase time	$T_{128kpperase}$	—	500	1250	7500	ms
11	Minimum operating frequency for program and erase operations ⁶	—	25	—	—	—	MHz

¹ Typical program and erase times are calculated at 25 °C operating temperature using nominal supply values.

² Initial factory condition: ≤ 100 program/erase cycles, 25 °C, using a typical supply voltage measured at a minimum system frequency of 80 MHz.

³ The maximum erase time occurs after the specified number of program/erase cycles. This maximum value is characterized but not guaranteed.

⁴ Actual hardware programming times. This does not include software overhead.

⁵ Page size is 256 bits (8 words).

⁶ The read frequency of the flash can range up to the maximum operating frequency. There is no minimum read frequency condition.

Table 15. Flash EEPROM Module Life ($T_A = T_L$ to T_H)

Spec	Characteristic	Symbol	Min.	Typical ¹	Unit
1a	Number of program/erase cycles per block for 16 KB, 48 KB, and 64 KB blocks over the operating temperature range (T_J)	P/E	100,000	—	cycles
1b	Number of program/erase cycles per block for 128 KB blocks over the operating temperature range (T_J)	P/E	1000	100,000	cycles
2	Data retention Blocks with 0–1,000 P/E cycles Blocks with 1,001–100,000 P/E cycles	Retention	20 5	— —	years

¹ Typical endurance is evaluated at 25° C. Product qualification is performed to the minimum specification. For additional information on the Freescale definition of typical endurance, refer to engineering bulletin EB619 Typical Endurance for Nonvolatile Memory.

Table 16 shows the FLASH_BIU settings versus frequency of operation. Refer to the device reference manual for definitions of these bit fields.

Table 16. FLASH_BIU Settings vs. Frequency of Operation ¹

Maximum Frequency (MHz)	APC	RWSC	WWSC	DPFEN ²	IPFEN ²	PFLIM ³	BFEN ⁴
Up to and including 82 MHz ⁵	0b001	0b001	0b01	0b00 0b01 0b11	0b00 0b01 0b11	0b000 to 0b110	0b0 0b1
Up to and including 102 MHz ⁶	0b001	0b010	0b01	0b00 0b01 0b11	0b00 0b01 0b11	0b000 to 0b110	0b0 0b1
Up to and including 132 MHz ⁷	0b010	0b011	0b01	0b00 0b01 0b11	0b00 0b01 0b11	0b000 to 0b110	0b0 0b1
Default setting after reset	0b111	0b111	0b11	0b00	0b00	0b000	0b0

¹ Illegal combinations exist. Use entries from the same row in this table.

² For maximum flash performance, set to 0b11.

³ For maximum flash performance, set to 0b110.

⁴ For maximum flash performance, set to 0b1.

⁵ 82 MHz parts allow for 80 MHz system clock + 2% frequency modulation (FM).

⁶ 102 MHz parts allow for 100 MHz system clock + 2% FM.

⁷ 132 MHz parts allow for 128 MHz system clock + 2% FM.

3.12 AC Specifications

3.12.1 Pad AC Specifications

Table 17. Pad AC Specifications ($V_{DDEH} = 5.0\text{ V}$, $V_{DDE} = 1.8\text{ V}$) ¹

Spec	Pad	SRC / DSC (binary)	Out Delay (ns) ^{2, 3, 4}	Rise / Fall (ns) ^{4, 5}	Load Drive (pF)
1	Slow high voltage (SH)	11	26	15	50
			82	60	200
		01	75	40	50
			137	80	200
		00	377	200	50
			476	260	200
2	Medium high voltage (MH)	11	16	8	50
			43	30	200
		01	34	15	50
			61	35	200
		00	192	100	50
			239	125	200

Electrical Characteristics
Table 17. Pad AC Specifications ($V_{DDEH} = 5.0\text{ V}$, $V_{DDE} = 1.8\text{ V}$)¹ (continued)

Spec	Pad	SRC / DSC (binary)	Out Delay ^{2, 3, 4} (ns)	Rise / Fall ^{4, 5} (ns)	Load Drive (pF)
3	Fast	00	3.1	2.7	10
		01		2.5	20
		10		2.4	30
		11		2.3	50
4	Pullup/down (3.6 V max)	—	—	7500	50
5	Pullup/down (5.5 V max)	—	—	9000	50

¹ These are worst-case values that are estimated from simulation (not tested). The values in the table are simulated at: $V_{DD} = 1.35\text{--}1.65\text{ V}$; $V_{DDE} = 1.62\text{--}1.98\text{ V}$; $V_{DDEH} = 4.5\text{--}5.25\text{ V}$; V_{DD33} and $V_{DDSYN} = 3.0\text{--}3.6\text{ V}$; and $T_A = T_L$ to T_H .

² This parameter is supplied for reference and is guaranteed by design (not tested).

³ The output delay is shown in [Figure 4](#). To calculate the output delay with respect to the system clock, add a maximum of one system clock to the output delay.

⁴ The output delay and rise and fall are measured to 20% or 80% of the respective signal.

⁵ This parameter is guaranteed by characterization rather than 100% tested.

Table 18. Derated Pad AC Specifications ($V_{DDEH} = 3.3\text{ V}$, $V_{DDE} = 3.3\text{ V}$)¹

Spec	Pad	SRC/DSC (binary)	Out Delay ^{2, 3, 4} (ns)	Rise / Fall ^{3, 5} (ns)	Load Drive (pF)
1	Slow high voltage (SH)	11	39	23	50
			120	87	200
		01	101	52	50
			188	111	200
		00	507	248	50
			597	312	200
2	Medium high voltage (MH)	11	23	12	50
			64	44	200
		01	50	22	50
			90	50	200
		00	261	123	50
			305	156	200
3	Fast	3.2	3.2	2.4	10
				2.2	20
				2.1	30
				2.1	50
4	Pullup/down (3.6 V max)	—	—	7500	50
5	Pullup/down (5.5 V max)	—	—	9500	50

¹ These are worst-case values that are estimated from simulation (not tested). The values in the table are simulated at: $V_{DD} = 1.35\text{--}1.65\text{ V}$; $V_{DDE} = 3.0\text{--}3.6\text{ V}$; $V_{DDEH} = 3.0\text{--}3.6\text{ V}$; V_{DD33} and $V_{DDSYN} = 3.0\text{--}3.6\text{ V}$; and $T_A = T_L$ to T_H .

² This parameter is supplied for reference and guaranteed by design (not tested).

- ³ The output delay, and the rise and fall, are calculated to 20% or 80% of the respective signal.
- ⁴ The output delay is shown in Figure 4. To calculate the output delay with respect to the system clock, add a maximum of one system clock to the output delay.
- ⁵ This parameter is guaranteed by characterization rather than 100% tested.

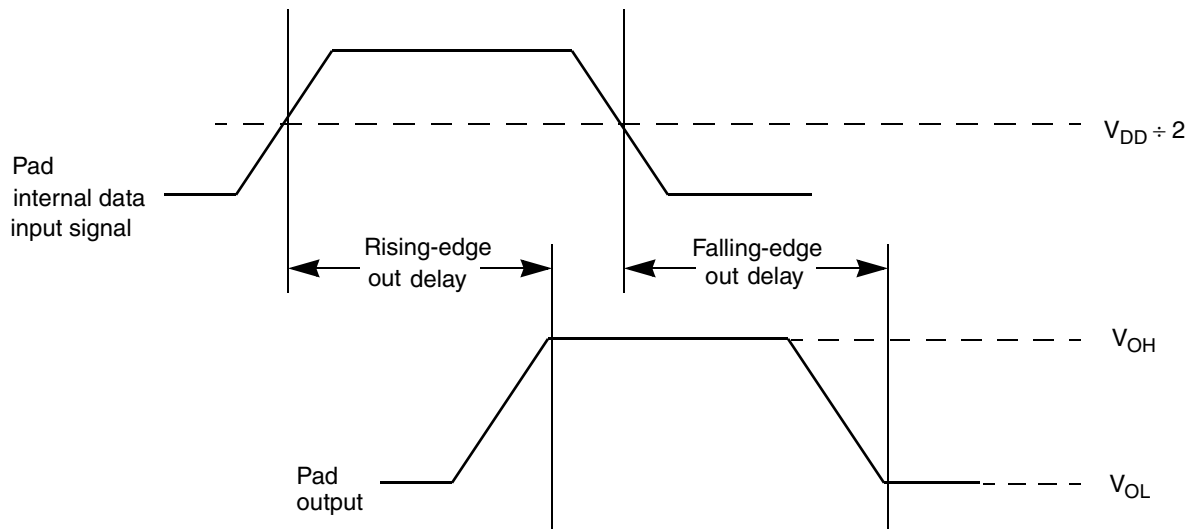

Figure 4. Pad Output Delay

3.13 AC Timing

3.13.1 Reset and Configuration Pin Timing

 Table 19. Reset and Configuration Pin Timing ¹

Spec	Characteristic	Symbol	Min.	Max.	Unit
1	$\overline{\text{RESET}}$ pulse width	t_{RPW}	10	—	t_{CYC}
2	$\overline{\text{RESET}}$ glitch detect pulse width	t_{GPW}	2	—	t_{CYC}
3	PLLCFG, BOOTCFG, WKPCFG, $\overline{\text{RSTCFG}}$ setup time to $\overline{\text{RSTOUT}}$ valid	t_{RCSU}	10	—	t_{CYC}
4	PLLCFG, BOOTCFG, WKPCFG, $\overline{\text{RSTCFG}}$ hold time from $\overline{\text{RSTOUT}}$ valid	t_{RCH}	0	—	t_{CYC}

¹ Reset timing specified at: $V_{\text{DDEH}} = 3.0\text{--}5.25\text{ V}$ and $T_{\text{A}} = T_{\text{L}}$ to T_{H} .

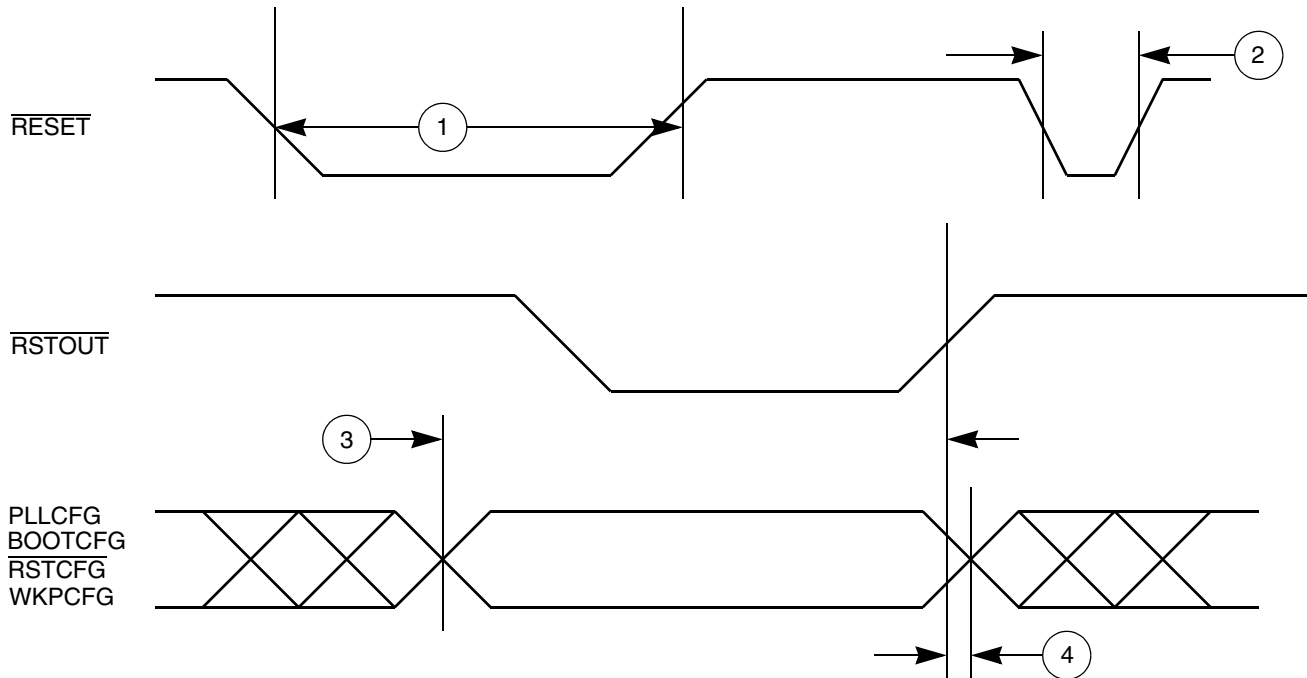
Electrical Characteristics

Figure 5. Reset and Configuration Pin Timing
3.13.2 IEEE 1149.1 Interface Timing
Table 20. JTAG Pin AC Electrical Characteristics ¹

Spec	Characteristic	Symbol	Min.	Max.	Unit
1	TCK cycle time	t_{JCYC}	100	—	ns
2	TCK clock pulse width (measured at $V_{DDE} \div 2$)	t_{JDC}	40	60	ns
3	TCK rise and fall times (40% to 70%)	$t_{TCKRISE}$	—	3	ns
4	TMS, TDI data setup time	t_{TMSS}, t_{TDIS}	5	—	ns
5	TMS, TDI data hold time	t_{TMSH}, t_{TDIH}	25	—	ns
6	TCK low to TDO data valid	t_{TDOV}	—	20	ns
7	TCK low to TDO data invalid	t_{TDOI}	0	—	ns
8	TCK low to TDO high impedance	t_{TDOHZ}	—	20	ns
9	JCOMP assertion time	t_{JCMPPW}	100	—	ns
10	JCOMP setup time to TCK low	t_{JCMPS}	40	—	ns
11	TCK falling-edge to output valid	t_{BSDV}	—	50	ns
12	TCK falling-edge to output valid out of high impedance	t_{BSDVZ}	—	50	ns
13	TCK falling-edge to output high impedance (Hi-Z)	t_{BSDHZ}	—	50	ns
14	Boundary scan input valid to TCK rising-edge	t_{BSDST}	50	—	ns
15	TCK rising-edge to boundary scan input invalid	t_{BSDHT}	50	—	ns

¹ These specifications apply to JTAG boundary scan only. JTAG timing specified at: $V_{DDE} = 3.0\text{--}3.6\text{ V}$ and $T_A = T_L$ to T_H . Refer to [Table 21](#) for Nexus specifications.

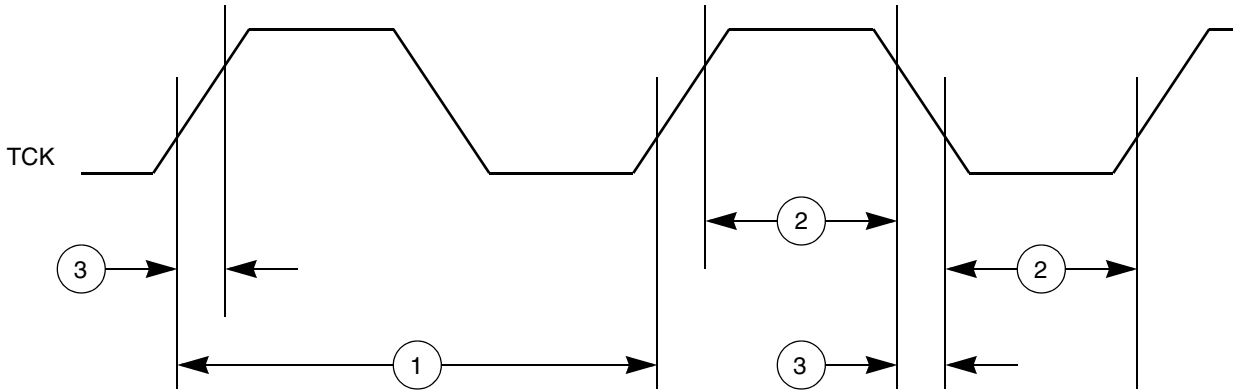

Figure 6. JTAG Test Clock Input Timing

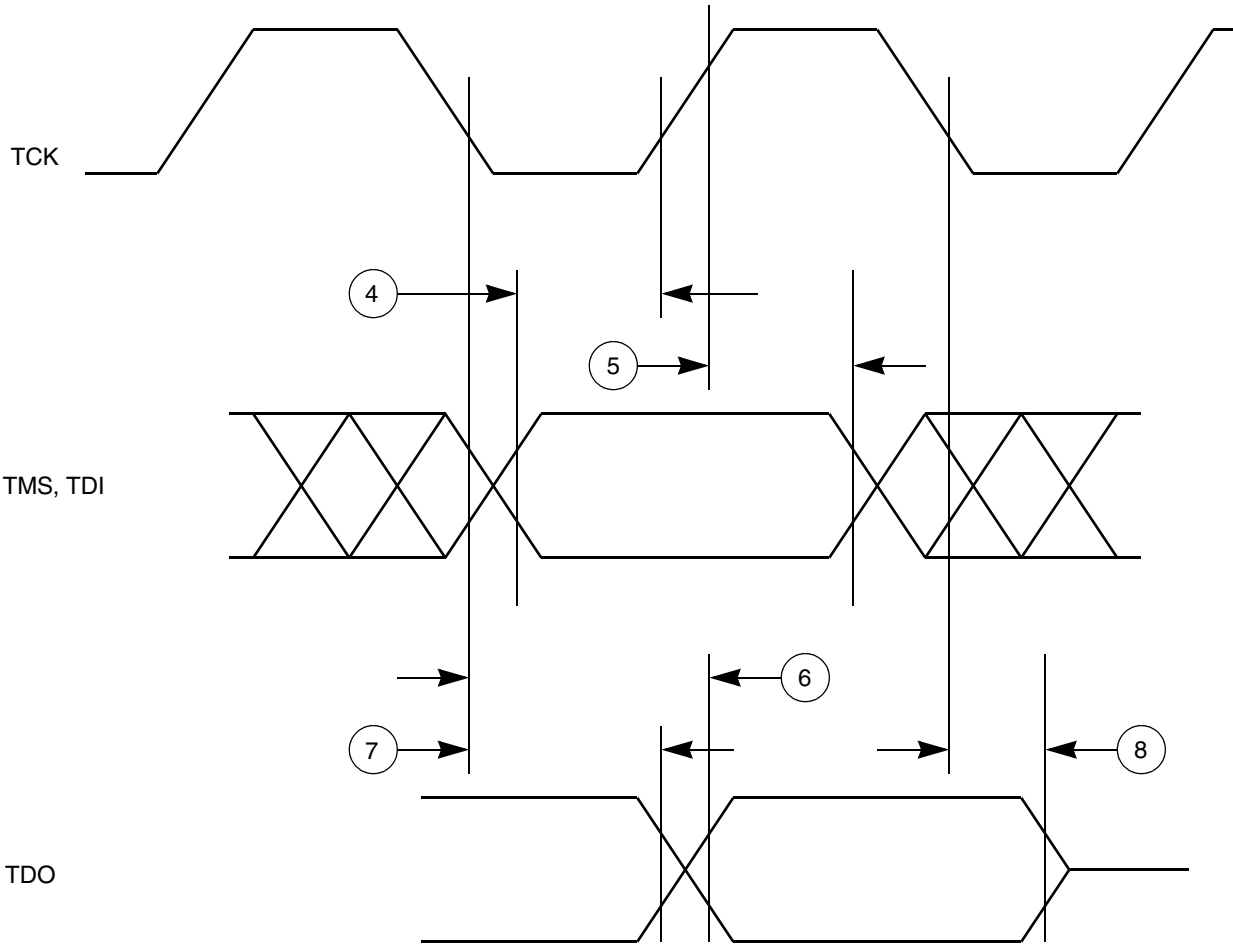

Figure 7. JTAG Test Access Port Timing

Electrical Characteristics

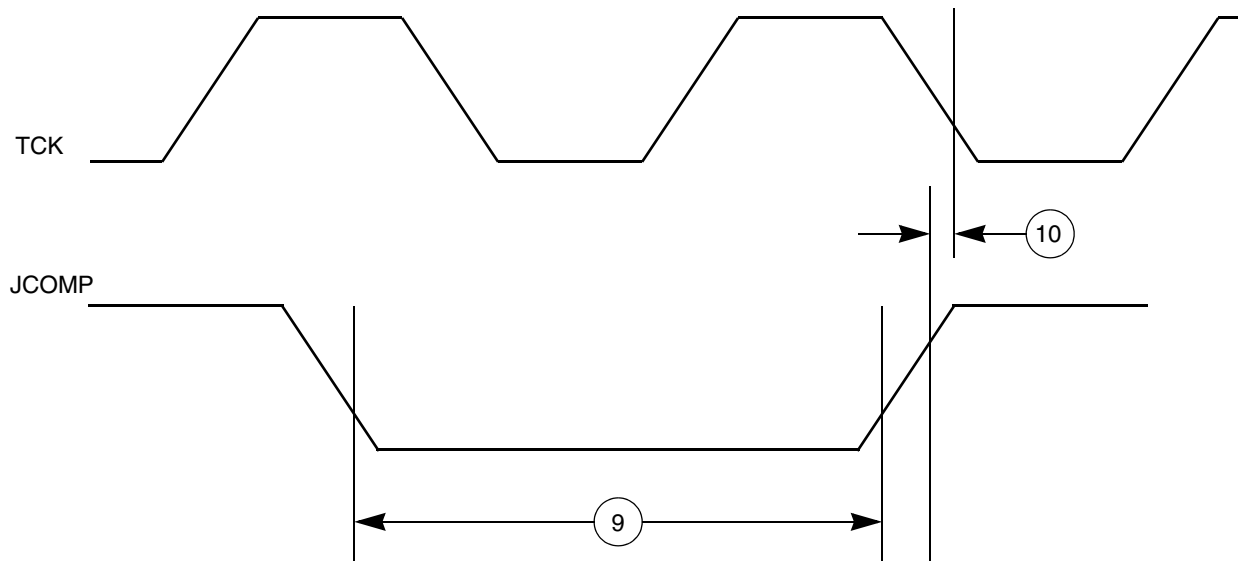

Figure 8. JTAG JCOMP Timing

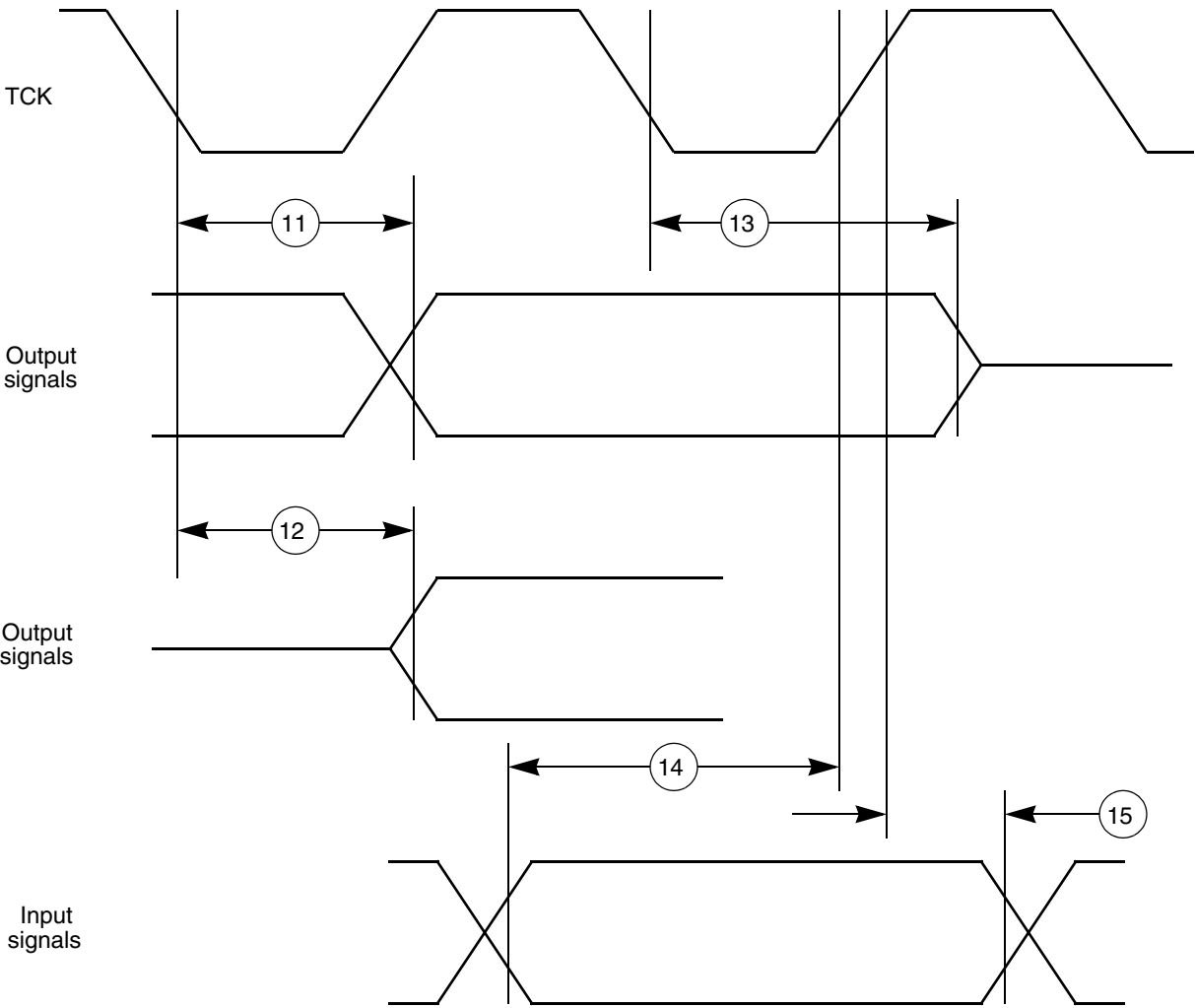

Figure 9. JTAG Boundary Scan Timing

Electrical Characteristics

3.13.3 Nexus Timing

 Table 21. Nexus Debug Port Timing ¹

Spec	Characteristic	Symbol	Min.	Max.	Unit
1	MCKO cycle time	t_{MICYC}	1 ²	8	t_{CYC}
2	MCKO duty cycle	t_{MDC}	40	60	%
3	MCKO low to MDO data valid ³	t_{MDOV}	-1.5	3.0	ns
4	MCKO low to \overline{MSEO} data valid ³	t_{MSEOV}	-1.5	3.0	ns
5	MCKO low to \overline{EVTO} data valid ³	t_{EVTOV}	-1.5	3.0	ns
6	\overline{EVTI} pulse width	t_{EVTIPW}	4.0	—	t_{TCYC}
7	\overline{EVTO} pulse width	t_{EVTOPW}	1	—	t_{MICYC}
8	TCK cycle time	t_{TCYC}	4 ⁴	—	t_{CYC}
9	TCK duty cycle	t_{TDC}	40	60	%
10	TDI, TMS data setup time	t_{NTDIS}, t_{NTMSS}	8	—	ns
11	TDI, TMS data hold time	t_{NTDIH}, t_{NTMSH}	5	—	ns
12	TCK low to TDO data valid	t_{JOV}	0	12	ns
	$V_{DDE} = 2.25\text{--}3.0\text{ V}$		0	10	ns
	$V_{DDE} = 3.0\text{--}3.6\text{ V}$				
13	\overline{RDY} valid to MCKO ⁵	—	—	—	—

¹ JTAG specifications apply when used for debug functionality. All Nexus timing relative to MCKO is measured from 50% of MCKO and 50% of the respective signal. Nexus timing specified at $V_{DD} = 1.35\text{--}1.65\text{ V}$, $V_{DDE} = 2.25\text{--}3.6\text{ V}$, V_{DD33} and $V_{DDSYN} = 3.0\text{--}3.6\text{ V}$, $T_A = T_L$ to T_H , and $CL = 30\text{ pF}$ with $DSC = 0b10$.

² The Nexus AUX port runs up to 82 MHz. Set `NPC_PCR[MCKO_DIV]` to divide-by-two if the system frequency is greater than 82 MHz.

³ MDO, \overline{MSEO} , and \overline{EVTO} data is held valid until the next MCKO low cycle occurs.

⁴ Limit the maximum frequency to approximately 16 MHz ($V_{DDE} = 2.25\text{--}3.0\text{ V}$) or 20 MHz ($V_{DDE} = 3.0\text{--}3.6\text{ V}$) to meet the timing specification for t_{JOV} of $[0.2 \times t_{JCYC}]$ as outlined in the IEEE-ISTO 5001-2003 specification.

⁵ The \overline{RDY} pin timing is asynchronous to MCKO and is guaranteed by design to function correctly.

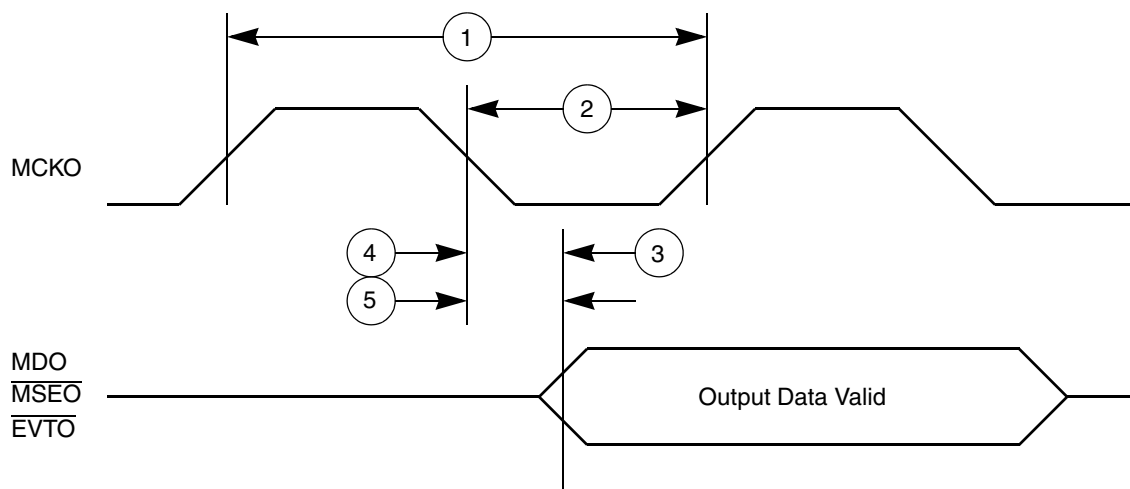

Figure 10. Nexus Output Timing

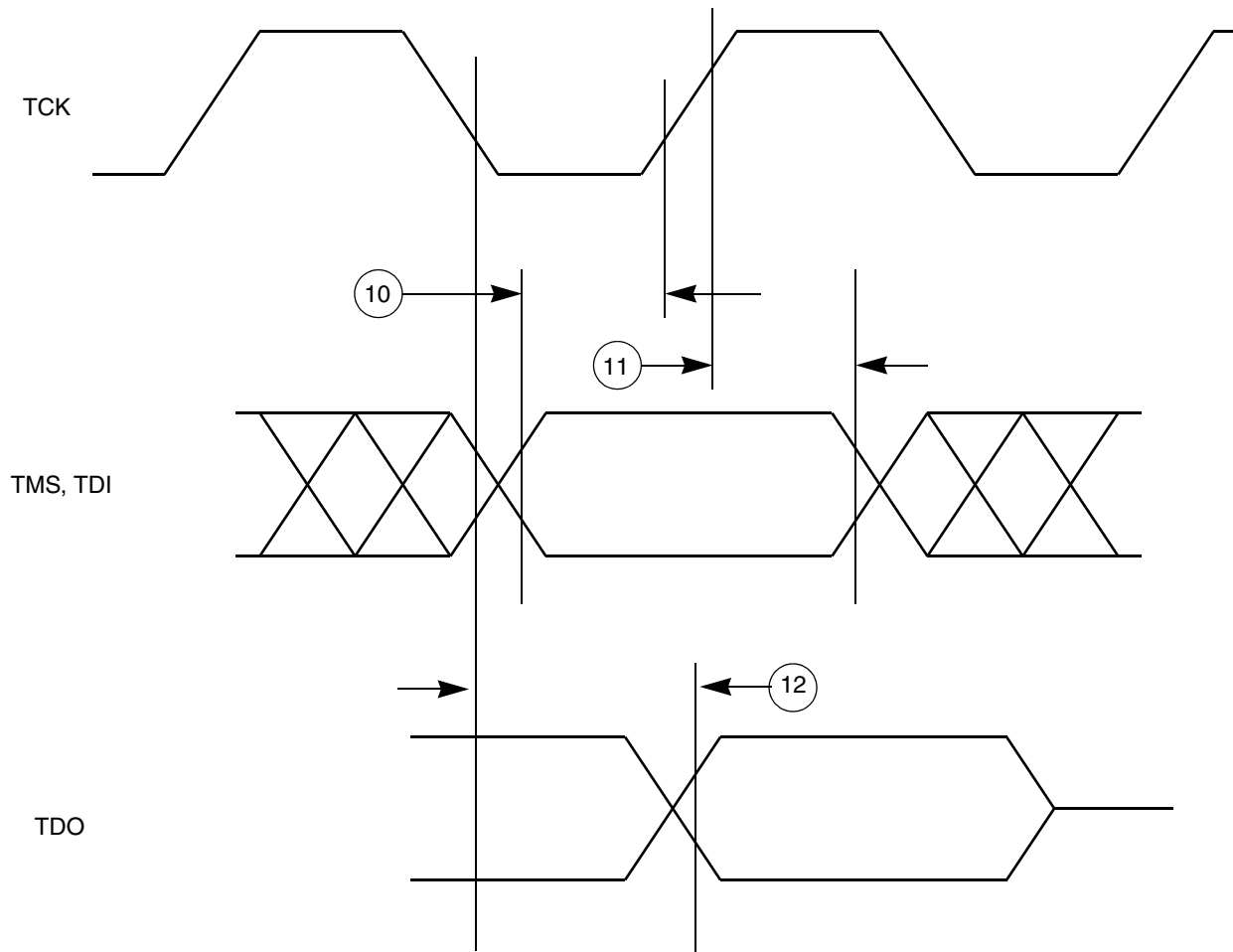

Figure 11. Nexus TDI, TMS, TDO Timing

Electrical Characteristics

3.13.4 External Bus Interface (EBI) Timing

Table 22 lists the timing information for the external bus interface (EBI).

Table 22. Bus Operation Timing¹

Spec	Characteristic and Description	Symbol	External Bus Frequency ^{2, 3}						Unit	Notes
			40 MHz		56 MHz		66 MHz			
			Min.	Max.	Min.	Max.	Min.	Max.		
1	CLKOUT period	T_C	24.4	—	17.5	—	15.2	—	ns	Signals are measured at 50% V_{DDE} .
2	CLKOUT duty cycle	t_{CDC}	45%	55%	45%	55%	45%	55%	T_C	
3	CLKOUT rise time	t_{CRT}	—	— ⁴	—	— ⁴	—	— ⁴	ns	
4	CLKOUT fall time	t_{CFT}	—	— ⁴	—	— ⁴	—	— ⁴	ns	
5	CLKOUT positive edge to output signal <i>invalid</i> or Hi-Z (hold time)	t_{COH}	1.0 ⁸	—	1.0 ⁸	—	1.0 ⁸	—	ns	EBTS = 0 EBTS = 1 Hold time selectable via SIU_ECCR [EBTS] bit.
	External bus interface $\overline{CS}[0:3]$ ADDR[8:31] DATA[0:31] ⁵ \overline{BDIP} \overline{OE} $\overline{RD_WR}$ \overline{TA} TEA ⁶ \overline{TS} $\overline{WE/BE}[0:3]$ ⁷		1.5	—	1.5	—	1.5	—		
	CLKOUT positive edge to output signal <i>invalid</i> or Hi-Z (hold time)	t_{CCOH}	1.0 ⁸	—	1.0 ⁸	—	1.0 ⁸	—	ns	EBTS = 0 EBTS = 1 Hold time selectable via SIU_ECCR [EBTS] bit.
	Calibration bus interface CAL_ $\overline{CS}[0, 2:3]$ CAL_ADDR[10:11, 27:30] CAL_DATA[0:15] CAL_ $\overline{WE/BE}[0:1]$		1.5	—	1.5	—	1.5	—		
6	CLKOUT positive edge to output signal <i>valid</i> (output delay)	t_{COV}	—	10.0 ⁸	—	7.5 ⁸	—	6.0 ⁸	ns	EBTS = 0 EBTS = 1 Output valid time selectable via SIU_ECCR [EBTS] bit.
	External bus interface $\overline{CS}[0:3]$ ADDR[8:31] DATA[0:31] ⁵ \overline{BDIP} \overline{OE} $\overline{RD_WR}$ \overline{TA} TEA ⁶ \overline{TS} $\overline{WE/BE}[0:3]$ ⁷		—	11.0	—	8.5	—	7.0		

Table 22. Bus Operation Timing¹ (continued)

Spec	Characteristic and Description	Symbol	External Bus Frequency ^{2, 3}						Unit	Notes
			40 MHz		56 MHz		66 MHz			
			Min.	Max.	Min.	Max.	Min.	Max.		
6a	CLKOUT positive edge to output signal valid (output delay)	t_{CCOV}	—	11.0 ⁸	—	8.5 ⁸	—	7.0 ⁸	ns	EBTS = 0 EBTS = 1 Output valid time selectable via SIU_ECCR [EBTS] bit.
	Calibration bus interface CAL_CS[0, 2:3] CAL_ADDR[10:11, 27:30] CAL_DATA[0:15] CAL_WE/BE[0:1]			12.0		9.5		8.0		
7	Input signal <i>valid</i> to CLKOUT positive edge (setup time)	t_{CIS}	10.0	—	7.0	—	5.0	—	ns	
	External bus interface ADDR[8:31] DATA[0:31] ⁵ RD_WR \overline{TA} \overline{TEA} ⁶ \overline{TS}									
	Input signal valid to CLKOUT positive edge (setup time)	t_{CCIS}	11.0	—	8.0	—	6.0	—	ns	
	Calibration bus interface CAL_ADDR[10:11, 27:30] CAL_DATA[0:15]									
8	CLKOUT positive edge to input signal <i>invalid</i> (hold time)	t_{CIH}	1.0	—	1.0	—	1.0	—	ns	
	External bus interface ADDR[8:31] DATA[0:31] ⁵ RD_WR \overline{TA} \overline{TEA} ⁶ \overline{TS}									
	Calibration bus interface CAL_ADDR[10:11, 27:30] CAL_DATA[0:15]	t_{CCH}	1.0	—	1.0	—	1.0	—	ns	

¹ EBI timing specified at: $V_{DDE} = 1.6\text{--}3.6$ V (unless stated otherwise); $T_A = T_L$ to T_H ; and $CL = 30$ pF with DSC = 0b10.

² Speed is the nominal maximum frequency. Max. speed is the maximum speed allowed including frequency modulation (FM). 82 MHz parts allow for 80 MHz system clock + 2% FM; 114 MHz parts allow for 112 MHz system clock + 2% FM; and 132 MHz parts allow for 128 MHz system clock + 2% FM.

³ The external bus is limited to half the speed of the internal bus.

⁴ Refer to fast pad timing in Table 17 and Table 18 (different values for 1.8 V and 3.3 V).

⁵ Due to pin limitations, the DATA[16:31] signals are not available on the 324 package.

Electrical Characteristics

- ⁶ Due to pin limitations, the \overline{TEA} signal is not available on the 324 package.
- ⁷ Due to pin limitations, the $\overline{WE/BE}[2:3]$ signals are not available on the 324 package.
- ⁸ $SIU_ECCR[EBTS] = 0$ timings are tested and valid at $V_{DDE} = 2.25\text{--}3.6\text{ V}$ only; $SIU_ECCR[EBTS] = 1$ timings are tested and valid at $V_{DDE} = 1.6\text{--}3.6\text{ V}$.

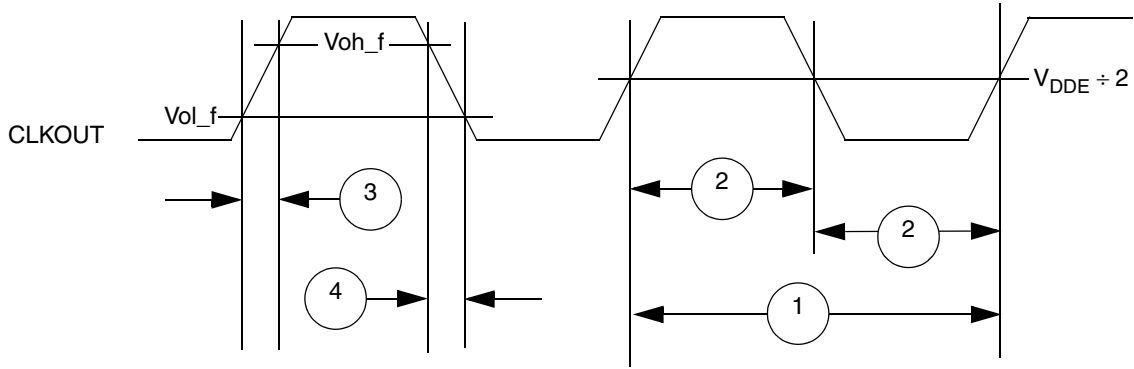

Figure 12. CLKOUT Timing

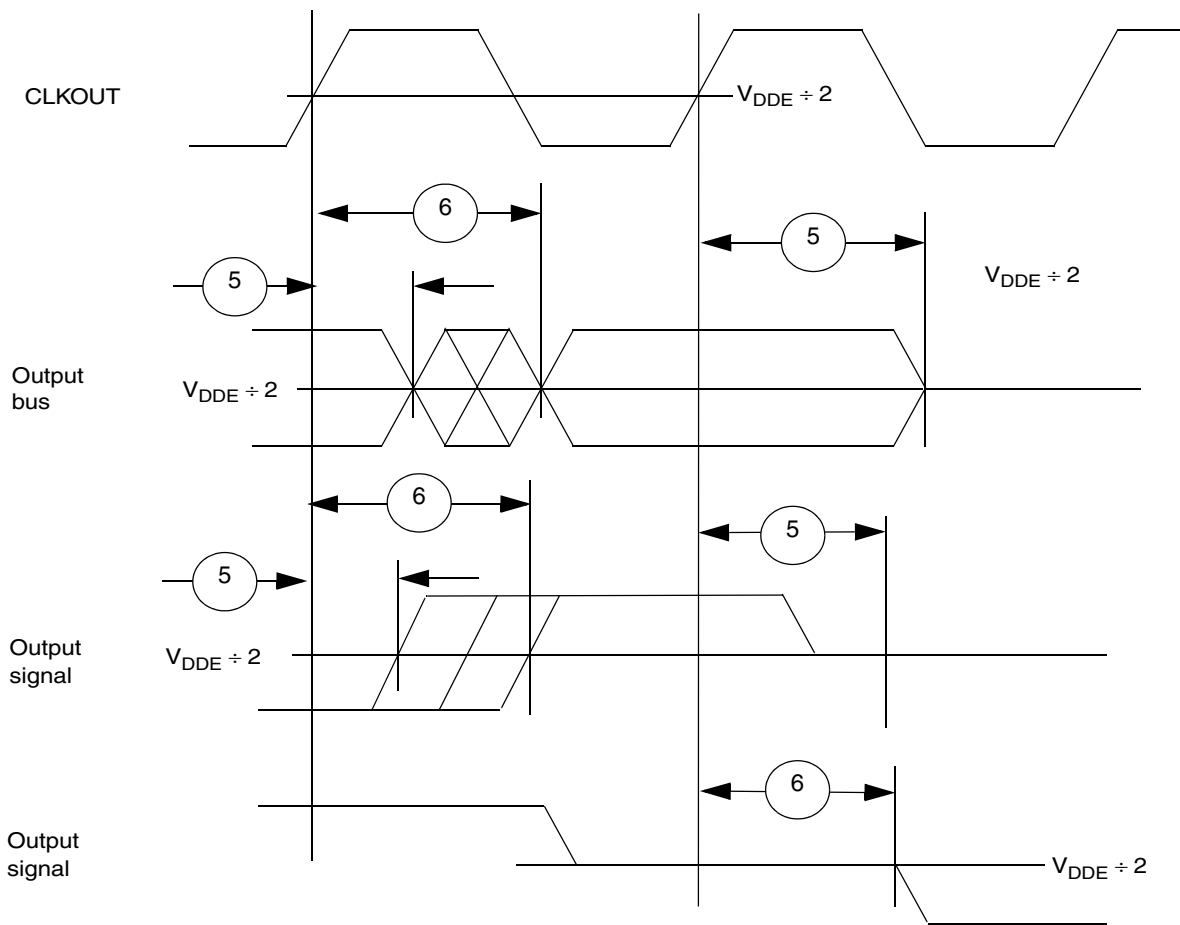

Figure 13. Synchronous Output Timing

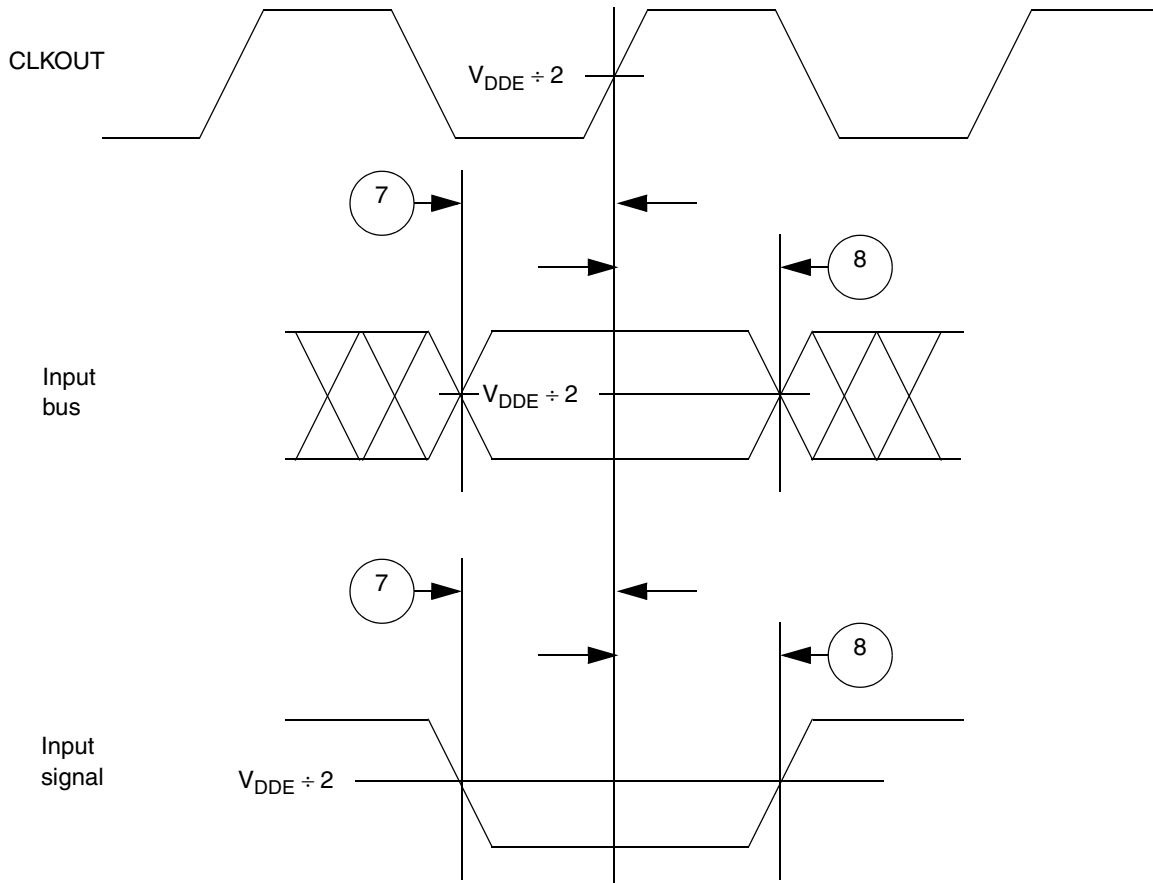

Figure 14. Synchronous Input Timing

3.13.5 External Interrupt Timing (IRQ Signals)

 Table 23. External Interrupt Timing ¹

Spec	Characteristic	Symbol	Min.	Max.	Unit
1	IRQ pulse-width low	t_{IPWL}	3	—	t_{CYC}
2	IRQ pulse-width high	T_{IPWH}	3	—	t_{CYC}
3	IRQ edge-to-edge time ²	t_{ICYC}	6	—	t_{CYC}

¹ IRQ timing specified at: $V_{DDEH} = 3.0\text{--}5.25\text{ V}$ and $T_A = T_L$ to T_H .

² Applies when IRQ signals are configured for rising-edge or falling-edge events, but not both.

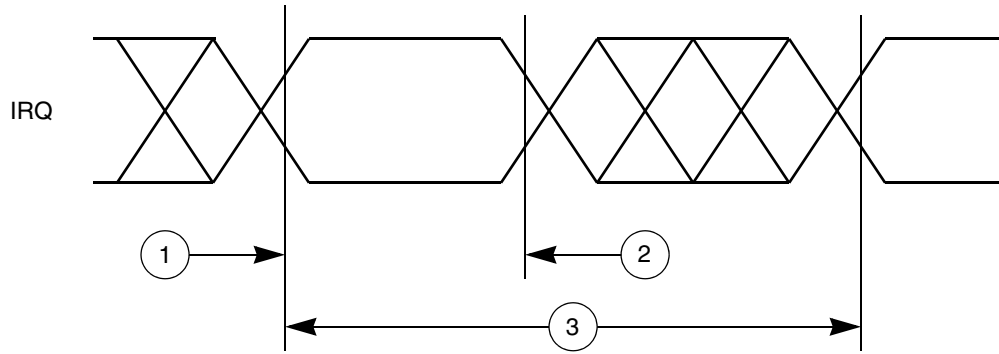
Electrical Characteristics

Figure 15. External Interrupt Timing
3.13.6 eTPU Timing
Table 24. eTPU Timing ¹

Spec	Characteristic	Symbol	Min.	Max	Unit
1	eTPU input channel pulse width	t_{ICPW}	4	—	t_{CYC}
2	eTPU output channel pulse width	t_{OCPW}	2 ²	—	t_{CYC}

¹ eTPU timing specified at: $V_{DDEH} = 3.0\text{--}5.25\text{ V}$ and $T_A = T_L$ to T_H .

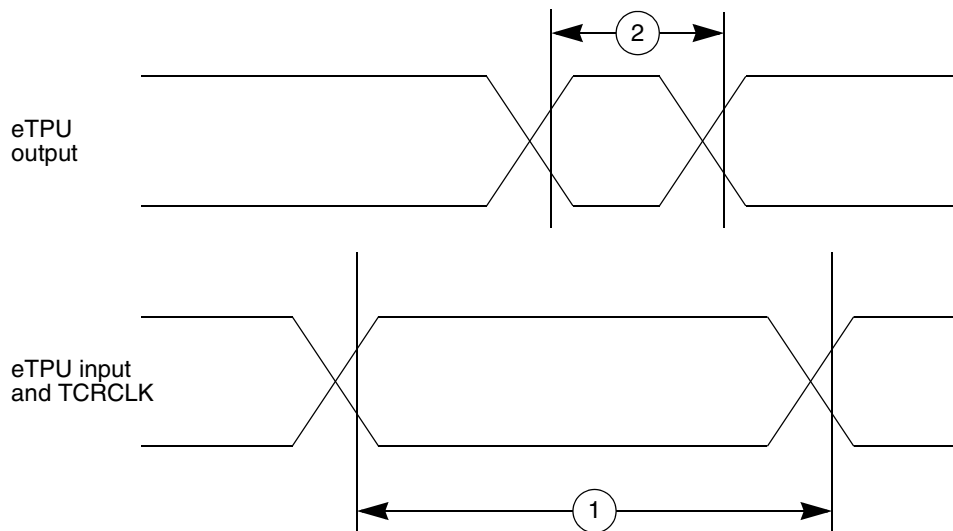
² This specification does not include the rise and fall times. When calculating the minimum eTPU pulse width, include the rise and fall times defined in the slew rate control fields (SRC) of the pad configuration registers (PCR).

Figure 16. eTPU Timing

3.13.7 eMIOS Timing

Table 25. eMIOS Timing ¹

Spec	Characteristic	Symbol	Min.	Max.	Unit
1	eMIOS input pulse width	t_{MIPW}	4	—	t_{CYC}
2	eMIOS output pulse width	t_{MOPW}	1 ²	—	t_{CYC}

¹ eMIOS timing specified at: $V_{DDEH} = 3.0\text{--}5.25\text{ V}$ and $T_A = T_L$ to T_H .

² This specification does not include the rise and fall times. When calculating the minimum eMIOS pulse width, include the rise and fall times defined in the slew rate control field (SRC) in the pad configuration register (PCR).

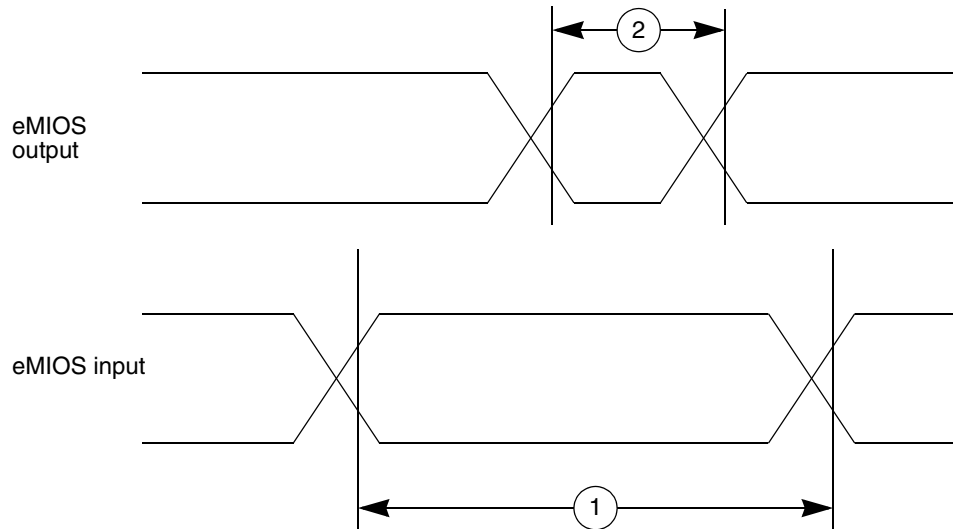
Figure 17. eMIOS Timing

3.13.8 DSPI Timing

Table 26. DSPI Timing^{1, 2}

Spec	Characteristic	Symbol	80 MHz		112 MHz		132 MHz		Unit
			Min.	Max.	Min.	Max.	Min.	Max.	
1	SCK cycle time ^{3, 4}	t_{SCK}	24.4 ns	2.9 ms	17.5 ns	2.1 ms	15.2 ns	1.7 ms	—
2	PCS to SCK delay ⁵	t_{CSC}	23	—	15	—	13	—	ns
3	After SCK delay ⁶	t_{ASC}	22	—	14	—	12	—	ns
4	SCK duty cycle	t_{SDC}	$(t_{SCK} \div 2) - 2\text{ ns}$	$(t_{SCK} \div 2) + 2\text{ ns}$	$(t_{SCK} \div 2) - 2\text{ ns}$	$(t_{SCK} \div 2) + 2\text{ ns}$	$(t_{SCK} \div 2) - 2\text{ ns}$	$(t_{SCK} \div 2) + 2\text{ ns}$	ns
5	Slave access time (\overline{SS} active to SOUT driven)	t_A	—	25	—	25	—	25	ns
6	Slave SOUT disable time (\overline{SS} inactive to SOUT Hi-Z, or invalid)	t_{DIS}	—	25	—	25	—	25	ns
7	PCSx to \overline{PCSS} time	t_{PCSC}	4	—	4	—	4	—	ns
8	\overline{PCSS} to PCSx time	t_{PASC}	5	—	5	—	5	—	ns

Electrical Characteristics
Table 26. DSPI Timing^{1, 2} (continued)

Spec	Characteristic	Symbol	80 MHz		112 MHz		132 MHz		Unit
			Min.	Max.	Min.	Max.	Min.	Max.	
9	Data setup time for inputs	t_{SUI}							
	Master (MTFE = 0)		20	—	20	—	20	—	ns
	Slave		2	—	2	—	2	—	ns
	Master (MTFE = 1, CPHA = 0) ⁷		—4	—	3	—	6	—	ns
	Master (MTFE = 1, CPHA = 1)		20	—	20	—	20	—	ns
10	Data hold time for inputs	t_{HI}							
	Master (MTFE = 0)		—4	—	—4	—	—4	—	ns
	Slave		7	—	7	—	7	—	ns
	Master (MTFE = 1, CPHA = 0) ⁷		21	—	14	—	12	—	ns
	Master (MTFE = 1, CPHA = 1)		—4	—	—4	—	—4	—	ns
11	Data valid (after SCK edge)	t_{SUO}							
	Master (MTFE = 0)		—	5	—	5	—	5	ns
	Slave		—	25	—	25	—	25	ns
	Master (MTFE = 1, CPHA = 0)		—	18	—	14	—	13	ns
	Master (MTFE = 1, CPHA = 1)		—	5	—	5	—	5	ns
12	Data hold time for outputs	t_{HO}							
	Master (MTFE = 0)		—5	—	—5	—	—5	—	ns
	Slave		5.5	—	5.5	—	5.5	—	ns
	Master (MTFE = 1, CPHA = 0)		8	—	4	—	3	—	ns
	Master (MTFE = 1, CPHA = 1)		—5	—	—5	—	—5	—	ns

¹ All DSPI timing specifications use the fastest slew rate (SRC = 0b11) on pad type M or MH. DSPI signals using pad types of S or SH have an additional delay based on the slew rate. DSPI timing is specified at: $V_{DDEH} = 3.0\text{--}5.25\text{ V}$; $T_A = T_L$ to T_H ; and $CL = 50\text{ pF}$ with SRC = 0b11.

² Speed is the nominal maximum frequency. Max. speed is the maximum speed allowed including frequency modulation (FM). 82 MHz parts allow for 80 MHz system clock + 2% FM; 114 MHz parts allow for 112 MHz system clock + 2% FM; and 132 MHz parts allow for 128 MHz system clock + 2% FM.

³ The minimum SCK cycle time restricts the baud rate selection for the given system clock rate. These numbers are calculated based on two MPC55xx devices communicating over a DSPI link.

⁴ The actual minimum SCK cycle time is limited by pad performance.

⁵ The maximum value is programmable in DSPI_CTARx[PSSCK] and DSPI_CTARx[CSSCK].

⁶ The maximum value is programmable in DSPI_CTARx[PASC] and DSPI_CTARx[ASC].

⁷ This number is calculated using the SMPL_PT field in DSPI_MCR set to 0b10.

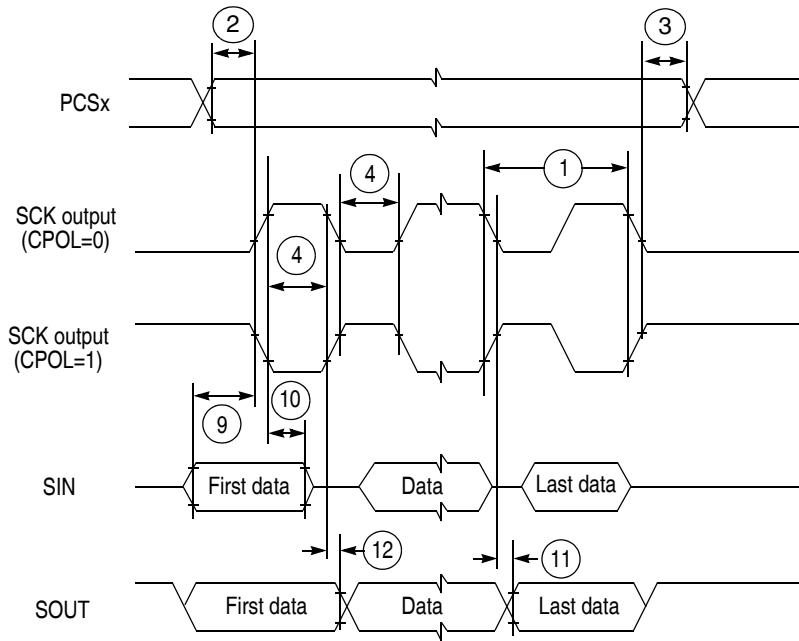

Figure 18. DSPI Classic SPI Timing—Master, CPHA = 0

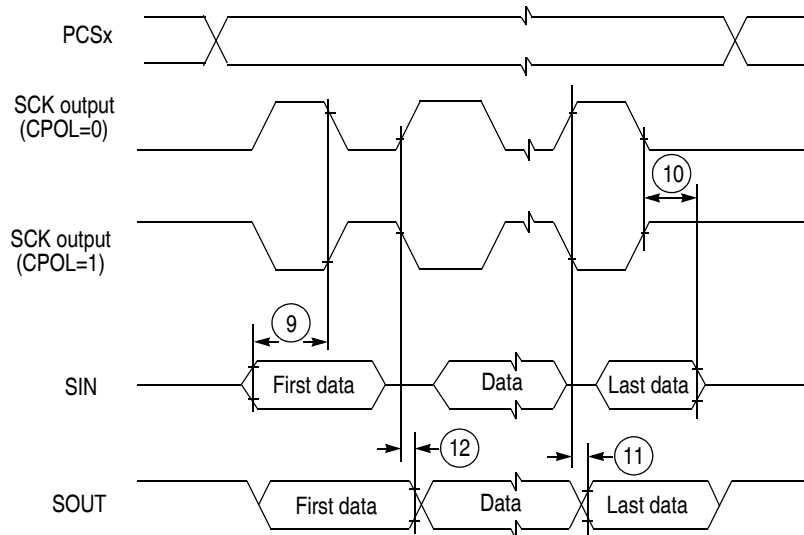
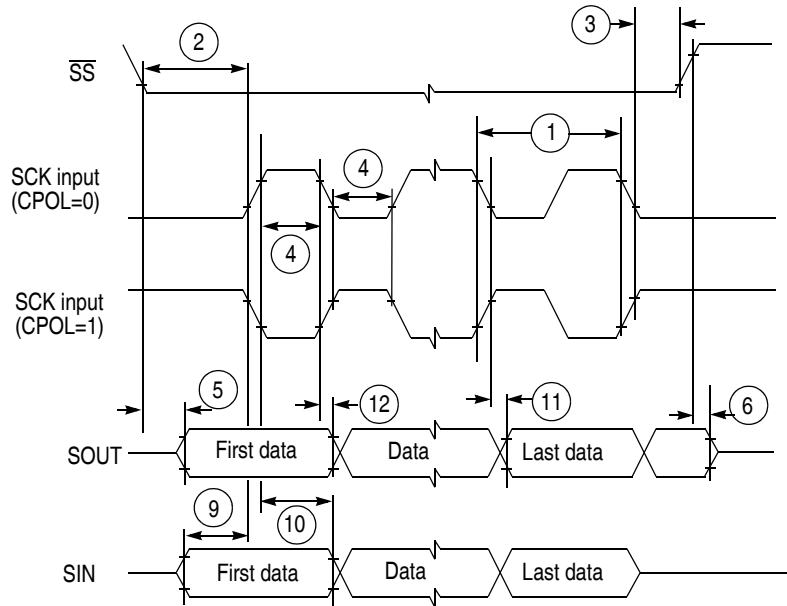
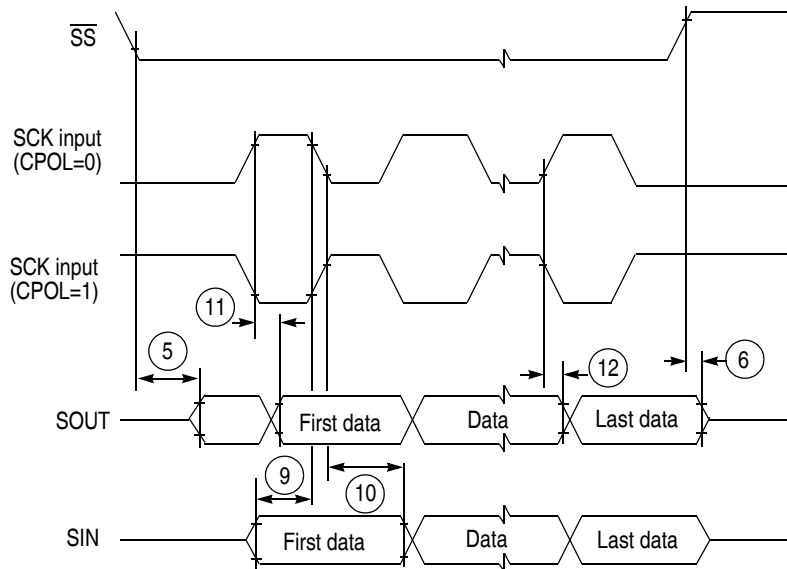

Figure 19. DSPI Classic SPI Timing—Master, CPHA = 1

Electrical Characteristics

Figure 20. DSPI Classic SPI Timing—Slave, CPHA = 0

Figure 21. DSPI Classic SPI Timing—Slave, CPHA = 1

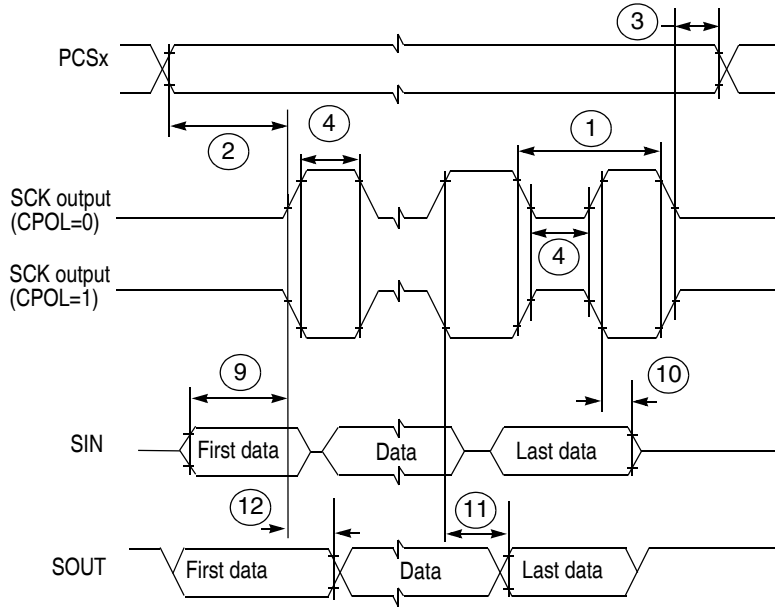

Figure 22. DSPI Modified Transfer Format Timing—Master, CPHA = 0

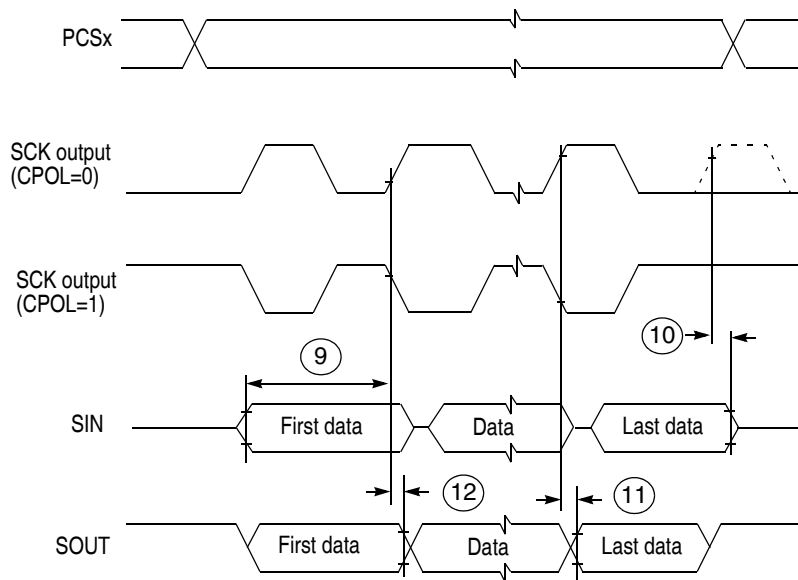
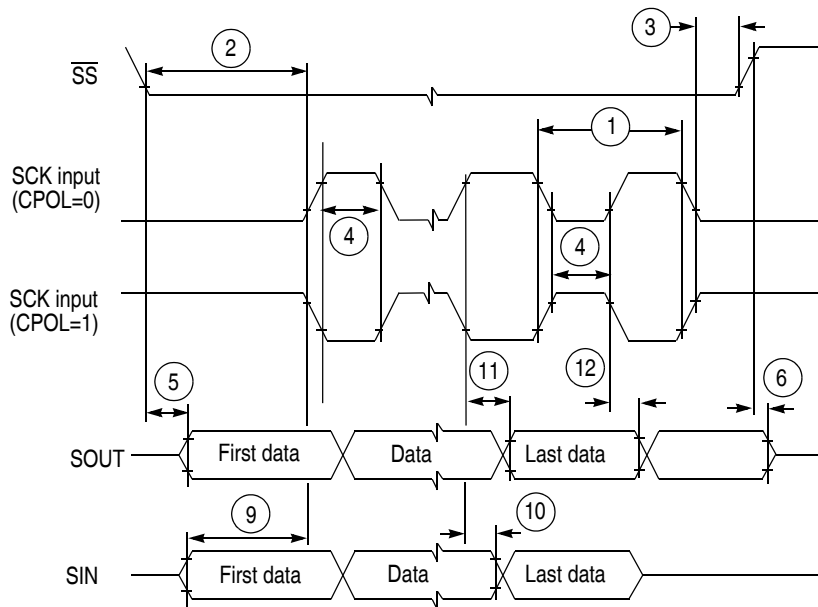
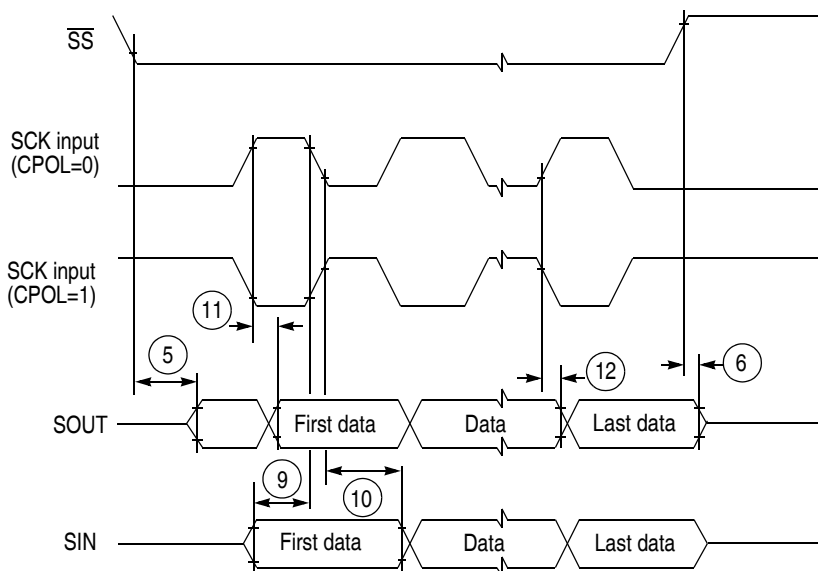
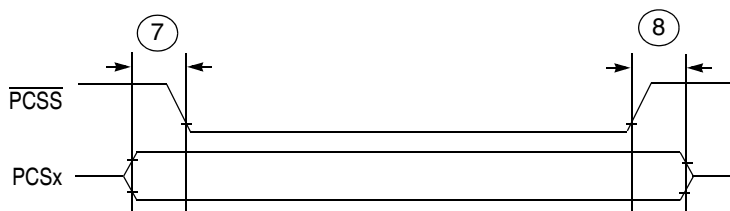

Figure 23. DSPI Modified Transfer Format Timing—Master, CPHA = 1

Electrical Characteristics

Figure 24. DSPI Modified Transfer Format Timing—Slave, CPHA = 0

Figure 25. DSPI Modified Transfer Format Timing—Slave, CPHA = 1

Figure 26. DSPI PCS Strobe ($\overline{\text{PCSS}}$) Timing

3.13.9 eQADC SSI Timing

Table 27. EQADC SSI Timing Characteristics

Spec	Rating	Symbol	Minimum	Typical	Maximum	Unit
2	FCK period ($t_{FCK} = 1 \div f_{FCK}$) ^{1, 2}	t_{FCK}	2	—	17	t_{SYS_CLK}
3	Clock (FCK) high time	t_{FCKHT}	$t_{SYS_CLK} - 6.5$	—	$9 \times (t_{SYS_CLK} + 6.5)$	ns
4	Clock (FCK) low time	t_{FCKLT}	$t_{SYS_CLK} - 6.5$	—	$8 \times (t_{SYS_CLK} + 6.5)$	ns
5	SDS lead / lag time	t_{SDS_LL}	-7.5	—	+7.5	ns
6	SDO lead / lag time	t_{SDO_LL}	-7.5	—	+7.5	ns
7	EQADC data setup time (inputs)	t_{EQ_SU}	22	—	—	ns
8	EQADC data hold time (inputs)	t_{EQ_HO}	1	—	—	ns

¹ SS timing specified at $V_{DDEH} = 3.0\text{--}5.25\text{ V}$, $T_A = T_L$ to T_H , and $CL = 25\text{ pF}$ with $SRC = 0b11$. Maximum operating frequency varies depending on track delays, master pad delays, and slave pad delays.

² FCK duty cycle is not 50% when it is generated through the division of the system clock by an odd number.

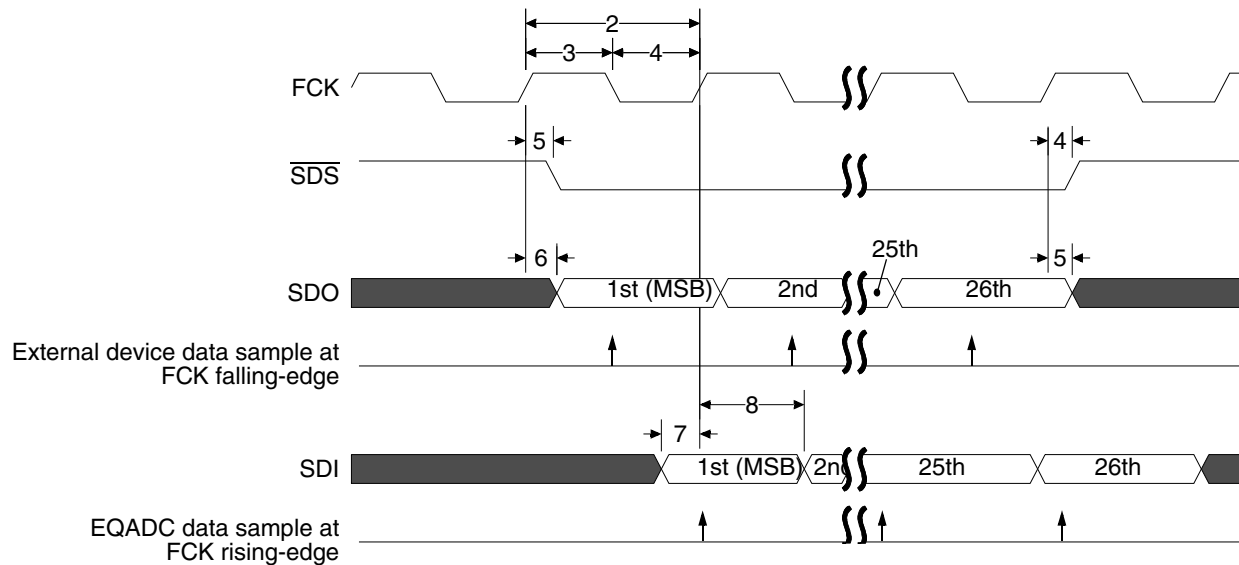
Figure 27. EQADC SSI Timing

Electrical Characteristics

3.14 Fast Ethernet AC Timing Specifications

Media Independent Interface (MII) Fast Ethernet Controller (FEC) signals use transistor-to-transistor logic (TTL) signal levels compatible with devices operating at 3.3 V. The timing specifications for the MII FEC signals are independent of the system clock frequency (part speed designation).

3.14.1 MII FEC Receive Signal Timing FEC_RXD[3:0], FEC_RX_DV, FEC_RX_ER, and FEC_RX_CLK

The receive functions correctly up to an FEC_RX_CLK maximum frequency of 25 MHz plus one percent. There is no minimum frequency requirement. The processor clock frequency must exceed four times the FEC_RX_CLK frequency.

Table 28 lists MII FEC receive channel timings.

Table 28. MII FEC Receive Signal Timing

Spec	Characteristic	Min.	Max	Unit
1	FEC_RXD[3:0], FEC_RX_DV, FEC_RX_ER to FEC_RX_CLK setup	5	—	ns
2	FEC_RX_CLK to FEC_RXD[3:0], FEC_RX_DV, FEC_RX_ER hold	5	—	ns
3	FEC_RX_CLK pulse-width high	35%	65%	FEC_RX_CLK period
4	FEC_RX_CLK pulse-width low	35%	65%	FEC_RX_CLK period

Figure 28 shows MII FEC receive signal timings listed in Table 28.

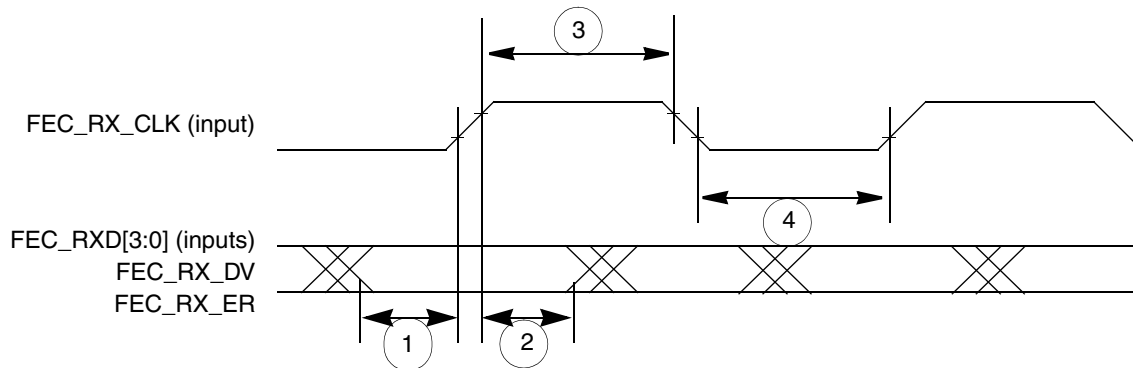

Figure 28. MII FEC Receive Signal Timing Diagram

3.14.2 MII FEC Transmit Signal Timing FEC_TXD[3:0], FEC_TX_EN, FEC_TX_ER, FEC_TX_CLK

The transmitter functions correctly up to the FEC_TX_CLK maximum frequency of 25 MHz plus one percent. There is no minimum frequency requirement. In addition, the processor clock frequency must exceed twice the FEC_TX_CLK frequency.

The transmit outputs (FEC_TXD[3:0], FEC_TX_EN, FEC_TX_ER) can be programmed to transition from either the rising- or falling-edge of TX_CLK, and the timing is the same in either case. These options allow the use of non-compliant MII PHYs.

Refer to the Fast Ethernet Controller (FEC) chapter of the device reference manual for details of this option and how to enable it.

Table 29 lists MII FEC transmit channel timings.

Table 29. MII FEC Transmit Signal Timing

Spec	Characteristic	Min.	Max	Unit
5	FEC_TX_CLK to FEC_TXD[3:0], FEC_TX_EN, FEC_TX_ER invalid	5	—	ns
6	FEC_TX_CLK to FEC_TXD[3:0], FEC_TX_EN, FEC_TX_ER valid	—	25	ns
7	FEC_TX_CLK pulse-width high	35%	65%	FEC_TX_CLK period
8	FEC_TX_CLK pulse-width low	35%	65%	FEC_TX_CLK period

Figure 29 shows MII FEC transmit signal timings listed in Table 29.

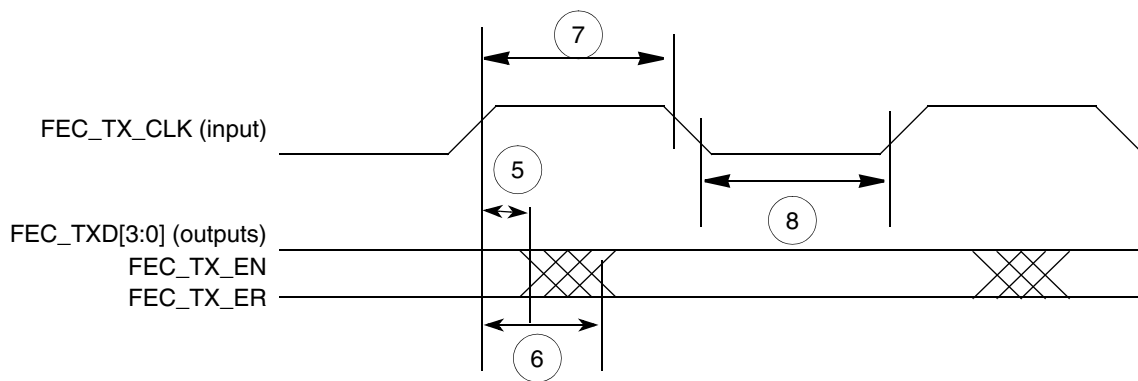

Figure 29. MII FEC Transmit Signal Timing Diagram

Electrical Characteristics

3.14.3 MII FEC Asynchronous Inputs Signal Timing FEC_CRIS and FEC_COL

Table 30 lists MII FEC asynchronous input signal timing.

Table 30. MII FEC Asynchronous Inputs Signal Timing

Spec	Characteristic	Min.	Max	Unit
9	FEC_CRIS, FEC_COL minimum pulse width	1.5	—	FEC_TX_CLK period

Figure 30 shows MII FEC asynchronous input timing listed in Table 30.

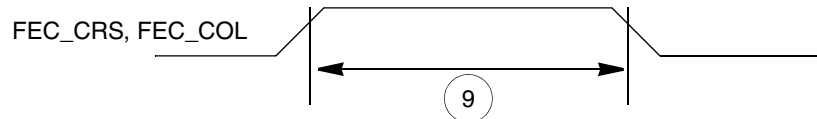

Figure 30. MII FEC Asynchronous Inputs Timing Diagram

3.14.4 MII FEC Serial Management Channel Timing FEC_MDIO and FEC_MDC

Table 31 lists MII FEC serial management channel timing. The FEC functions correctly with a maximum FEC_MDC frequency of 2.5 MHz.

Table 31. MII FEC Serial Management Channel Timing

Spec	Characteristic	Min.	Max	Unit
10	FEC_MDC falling-edge to FEC_MDIO output invalid (minimum propagation delay)	0	—	ns
11	FEC_MDC falling-edge to FEC_MDIO output valid (maximum propagation delay)	—	25	ns
12	FEC_MDIO (input) to FEC_MDC rising-edge setup	10	—	ns
13	FEC_MDIO (input) to FEC_MDC rising-edge hold	0	—	ns
14	FEC_MDC pulse-width high	40%	60%	FEC_MDC period
15	FEC_MDC pulse-width low	40%	60%	FEC_MDC period

Figure 31 shows MII FEC serial management channel timing listed in Table 31.

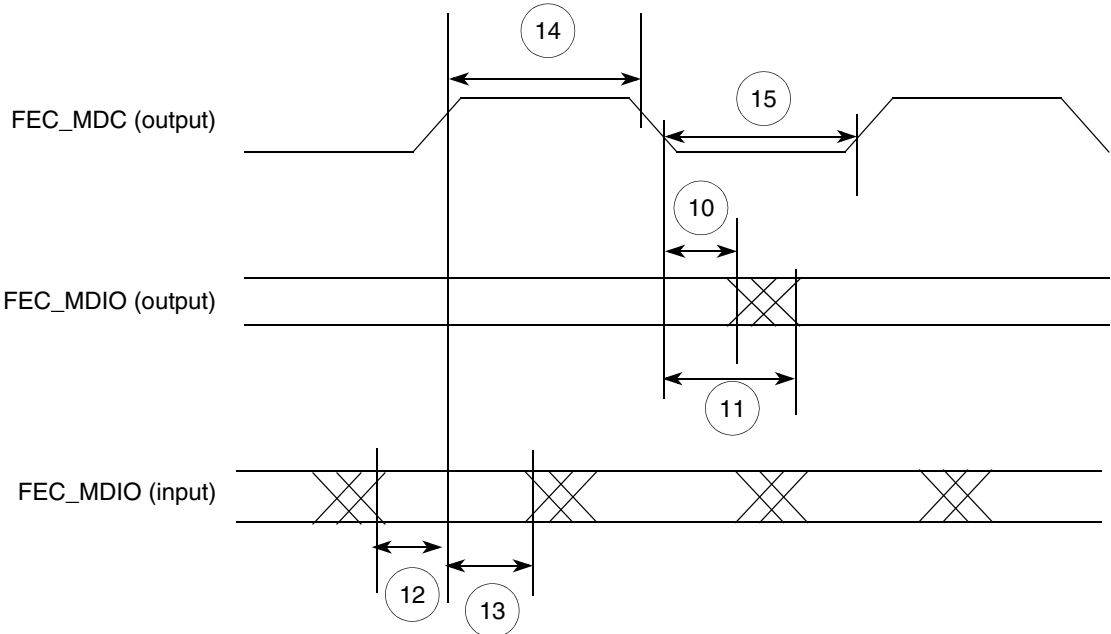

Figure 31. MII FEC Serial Management Channel Timing Diagram

Mechanicals

4 Mechanicals

4.1 MPC5553 208 MAP BGA Pinout

Figure 32 is a pinout for the MPC5553 208 MAP BGA package.

NOTE.

V_{DDEH10} and V_{DDEH6} are connected internally on the 208-ball package and are listed as V_{DDEH6} .

	1	2	3	4	5	6	7	8	9	10	11	12	13	14	15	16	
A	VSS	AN9	AN11	VDDA1	VSSA1	AN1	AN5	VRH	VRL	AN27	VSSA0	AN12	MDO2	MDO0	VDD33	VSS	A
B	VDD	VSS	AN38	AN21	AN0	AN4	REF BYPC	AN22	AN25	AN28	VDDA0	AN13	MDO3	MDO1	VSS	VDD	B
C	VSTBY	VDD	VSS	AN17	AN34	AN16	AN3	AN7	AN23	AN32	AN33	AN14	AN15	VSS	MSEO0	TCK	C
D	VDD33	AN39	VDD	VSS	AN18	AN2	AN6	AN24	AN30	AN31	AN35	VDDEH9	VSS	TMS	EVTO	TEST	D
E	ETPUA30	ETPUA31	AN37	VDD									VDDE7	TDI	EVTI	MSEO1	E
F	ETPUA28	ETPUA29	ETPUA26	AN36									VDDEH6	TDO	MCKO	JCOMP	F
G	ETPUA24	ETPUA27	ETPUA25	ETPUA21			VSS	VSS	VSS	VSS			SOUTB	PCSB3	SINB	PCSB0	G
H	ETPUA23	ETPUA22	ETPUA17	ETPUA18			VSS	VSS	VSS	VSS			PCSA3	PCSB4	PCSB2	PCSB1	H
J	ETPUA20	ETPUA19	ETPUA14	ETPUA13			VSS	VSS	VSS	VSS			PCSB5	TXDA	PCSA2	SCKB	J
K	ETPUA16	ETPUA15	ETPUA7	VDDEH1			VSS	VSS	VSS	VSS			CNTXC	RXDA	RSTOUT	VPP	K
L	ETPUA12	ETPUA11	ETPUA6	TCRCLKA									TXDB	CNRXC	WKP CFG	RESET	L
M	ETPUA10	ETPUA9	ETPUA1	ETPUA5									RXDB	PLL CFG0	BOOT CFG1	VSS SYN	M
N	ETPUA8	ETPUA4	ETPUA0	VSS	VDD	VDD33	EMIOS2	EMIOS10	VDDEH4	EMIOS12	EMIOS21	VDD33	VSS	VRC CTL	PLL CFG1	EXTAL	N
P	ETPUA3	ETPUA2	VSS	VDD	GPIO207	VDDE2	EMIOS6	EMIOS8	EMIOS16	EMIOS17	EMIOS22	CNTXA	VDD	VSS	VRC33	XTAL	P
R	CS0	VSS	VDD	GPIO206	EMIOS4	EMIOS3	EMIOS9	EMIOS11	EMIOS14	EMIOS19	EMIOS23	CNRXA	CNRXB	VDD	VSS	VDD SYN	R
T	VSS	VDD	OE	EMIOS0	EMIOS1	EMIOS5	EMIOS7	EMIOS13	EMIOS15	EMIOS18	EMIOS20	CNTXB	VDDE5	ENG CLK	VDD	VSS	T

Figure 32. MPC5553 208 Package

4.2 MPC5553 324 PBGA Pinouts

Figure 33 is a pinout for the MPC5553 324 PBGA package.

	1	2	3	4	5	6	7	8	9	10	11	12	13	14	15	16	17	18	19	20	21	22			
A	VSS	VDD	VSTBY	AN37	AN11	VDDA1	VSSA1	AN1	AN5	VRH	VRL	AN27	AN28	AN35	VSSA0	AN12	MDO11	MDO10	MDO8	VDD	VDD33	VSS	A		
B	VDD33	VSS	VDD	AN36	AN39	AN19	AN16	AN0	AN4	REF BYPC	AN23	AN26	AN31	AN32	VSSA0	AN13	MDO9	MDO7	MDO4	MDO0	VSS	VDDE7	B		
C	ETPUA 30	ETPUA 31	VSS	VDD	AN8	AN17	AN20	AN21	AN3	AN7	AN22	AN25	AN30	AN33	VDDA0	AN14	MDO5	MDO2	MDO1	VSS	VDDE7	VDD	C		
D	ETPUA 28	ETPUA 29	ETPUA 26	VSS	VDD	AN38	AN9	AN10	AN18	AN2	AN6	AN24	AN29	AN34	VDDEH 9	AN15	MDO6	MDO3	VSS	VDDE7	TCK	TDI	D		
E	ETPUA 24	ETPUA 27	ETPUA 25	ETPUA 21																VDDE7	TMS	TDO	TEST	E	
F	ETPUA 23	ETPUA 22	ETPUA 17	ETPUA 18																VDDE7	JCOMP	EVTI	EVTO	F	
G	ETPUA 20	ETPUA 19	ETPUA 14	ETPUA 13																RDY	MCKO	MSE00	MSE01	G	
H	ETPUA 16	ETPUA 15	ETPUA 10	VDDEH 1																VDDEH 10	GPIO 203	GPIO 204	SINB	H	
J	ETPUA 12	ETPUA 11	ETPUA 6	ETPUA 9					VSS	VSS	VSS	VSS	VSS	VSS	VDDE7					SOUTB	PCSB3	PCSB0	PCSB1	J	
K	ETPUA 8	ETPUA 7	ETPUA 2	ETPUA 5					VSS	VSS	VSS	VSS	VSS	VSS							PCSA3	PCSB4	SCKB	PCSB2	K
L	ETPUA 4	ETPUA 3	ETPUA 0	ETPUA 1					VSS	VSS	VSS	VSS	VSS	VSS							PCSB5	SOUTA	SINA	SCKA	L
M	BDIP	TCRCLK A	CS1	CS0					VDDE2	VDDE2	VSS	VSS	VSS	VSS							PCSA1	PCSA0	PCSA2	VPP	M
N	CS3	CS2	WE1	WE0					VSS	VSS	VDDE2	VSS	VSS	VSS							PCSA4	TXDA	PCSA5	VFLASH	N
P	ADDR 16	ADDR 17	RD_WR	VDD33					VSS	VSS	VDDE2	VSS	VSS	VSS							CNTXC	RXDA	RSTOUT	RST CFG	P
R	ADDR 18	ADDR 19	VDDE2	TA																	WKP CFG	CNRXC	TXDB	RESET	R
T	ADDR 20	ADDR 21	ADDR 12	TS																	RXDB	BOOT CFG1	PLL CFG2	VSS SYN	T
U	ADDR 22	ADDR 23	ADDR 13	ADDR 14																	VDDEH 6	PLL CFG1	BOOT CFG0	EXTAL	U
V	ADDR 24	ADDR 25	ADDR 15	ADDR 31																	VDD	VRC CTL	PLL CFG0	XTAL	V
W	ADDR 26	VDDE2	ADDR 30	VSS	VDD	VDDE2	VDD33	VDDE2	DATA 11	DATA 12	DATA 14	EMIOS 2	EMIOS 8	VDDEH 4	EMIOS 12	EMIOS 21	VDDE5	NC	VSS	VDD	VRC33	VDD SYN	W		
Y	ADDR 28	ADDR 27	VSS	VDD	VDDE2	DATA 8	DATA 9	DATA 10	GPIO 207	DATA 13	DATA 15	EMIOS 6	EMIOS 10	EMIOS 15	EMIOS 17	EMIOS 22	CNTXA	VDDE5	NC	VSS	VDD	VDD33	Y		
AA	ADDR 29	VSS	VDD	VDDE2	DATA 1	VDDE2	GPIO 206	DATA 5	DATA 7	VDDE2	EMIOS 3	EMIOS 5	EMIOS 9	EMIOS 13	EMIOS 16	EMIOS 19	EMIOS 23	CNRXA	VDDE5	CLKOUT	VSS	VDD	AA		
AB	VSS	VDD	VDDE2	DATA 0	DATA 2	DATA 3	DATA 4	DATA 6	OE	EMIOS 0	EMIOS 1	EMIOS 4	EMIOS 7	EMIOS 11	EMIOS 14	EMIOS 18	EMIOS 20	CNTXB	CNRXB	VDDE5	ENG CLK	VSS	AB		

Note: NC No connect. Reserved (W18 & Y19 are shorted to each other)

Figure 33. MPC5553 324 Package

4.3 MPC5553 416 PBGA Pinout

Figure 34, Figure 35, and Figure 36 show the pinout for the MPC5553 416 PBGA package. The alternate Fast Ethernet Controller (FEC) signals are multiplexed with the data calibration bus signals.

NOTE

The MPC5500 devices are pin compatible for software portability and use the primary function names to label the pins in the BGA diagram. Although some devices do not support all the primary functions shown in the BGA diagram, the muxed and GPIO signals on those pins remain available. See the signals chapter in the device reference manual for the signal muxing.

Mechanicals

	1	2	3	4	5	6	7	8	9	10	11	12	13	14	15	16	17	18	19	20	21	22	23	24	25	26		
A	VSS	VSTBY	AN37	AN11	VDDA1	AN16	AN1	AN5	VRH	AN23	AN27	AN28	AN35	VSSA0	AN15	ETRIG1	ETPUB18	ETPUB20	ETPUB24	ETPUB27	GPIO205	MDO11	MDO8	VDD	VDD33	VSS	A	
B	VDD	VSS	AN36	AN39	AN19	AN20	AN0	AN4	REFBYPC	AN22	AN26	AN31	AN32	VSSA0	AN14	ETRIG0	ETPUB21	ETPUB25	ETPUB28	ETPUB31	MDO10	MDO7	MDO4	MDO0	VSS	VDDE7	B	
C	VDD33	VDD	VSS	AN8	AN17	VSSA1	AN21	AN3	AN7	VRL	AN25	AN30	AN33	VDDA0	AN13	ETPUB19	ETPUB22	ETPUB26	ETPUB30	MDO9	MDO6	MDO3	MDO1	VSS	VDDE7	VDD	C	
D	ETPUA30	ETPUA31	VDD	VSS	AN38	AN9	AN10	AN18	AN2	AN6	AN24	AN29	AN34	VDDEH9	AN12	ETPUB16	ETPUB17	ETPUB23	ETPUB29	MDO5	MDO2	VDDEH8	VSS	VDDE7	TCK	TDI	D	
E	ETPUA28	ETPUA29	VDDEH1	VDD																			VDDE7	TMS	TDO	TEST	E	
F	ETPUA24	ETPUA27	ETPUA26	VDDEH1																			MSE00	JCOMP	EVTI	EVTO	F	
G	ETPUA23	ETPUA22	ETPUA25	ETPUA21																			MSE01	MCKO	GPIO204	ETPUB15	G	
H	ETPUA20	ETPUA19	ETPUA18	ETPUA17																			RDY	GPIO203	ETPUB14	ETPUB13	H	
J	ETPUA16	ETPUA15	ETPUA14	ETPUA13																			VDDEH6	ETPUB12	ETPUB11	ETPUB9	J	
K	ETPUA12	ETPUA11	ETPUA10	ETPUA9																			ETPUB10	ETPUB8	ETPUB7	ETPUB5	K	
L	ETPUA8	ETPUA7	ETPUA6	ETPUA5																			ETPUB6	ETPUB4	ETPUB3	ETPUB2	L	
M	ETPUA4	ETPUA3	ETPUA2	ETPUA1																			TCRCLKB	ETPUB1	ETPUB0	SINB	M	
N	BDIP	TEA	ETPUA0	TORCLKA																			SOUTB	PCSB3	PCSB0	PCSB1	N	
P	CS3	CS2	CS1	CS0																			PCSA3	PCSB4	SCKB	PCSB2	P	
R	WE3	WE2	WE1	WE0																			PCSB5	SOUTA	SINA	SCKA	R	
T	VDDE2	TSIZ0	RD_WR	VDDE2																			PCSA1	PCSA0	PCSA2	VPP	T	
U	ADDR16	TSIZ1	TA	VDD33																			PCSA4	TXDA	PCSA5	VFLASH	U	
V	ADDR18	ADDR17	TS	ADDR8																			CNTXC	RXDA	RSTOUT	RSTCFG	V	
W	ADDR20	ADDR19	ADDR9	ADDR10																				RXDB	CNRXC	TXDB	RESET	W
Y	ADDR22	ADDR21	ADDR11	VDDE2																				WKP_CFG	BOOT_CFG1	VRC_VSS	VSS_SYN	Y
AA	ADDR24	ADDR23	ADDR13	ADDR12																				VDDEH6	PLL_CFG1	BOOT_CFG0	EXTAL	AA
AB	VDDE2	ADDR25	ADDR15	ADDR14																				VDD	VRC_CTL	PLL_CFG0	XTAL	AB
AC	ADDR26	ADDR27	ADDR31	VSS	VDD	DATA26	DATA28	VDDE2	DATA30	DATA31	DATA8	DATA10	VDDE2	DATA12	DATA14	EMIOS2	EMIOS8	EMIOS12	EMIOS21	VDDEH4	VDDE5	NC	VSS	VDD	VRC33	VDD_SYN	AC	
AD	ADDR28	ADDR30	VSS	VDD	DATA24	DATA25	DATA27	DATA29	VDD33	GPIO207	DATA9	DATA11	DATA13	DATA15	EMIOS3	EMIOS6	EMIOS10	EMIOS15	EMIOS17	EMIOS22	CNTXA	VDDE5	NC	VSS	VDD	VDD33	AD	
AE	ADDR29	VSS	VDD	DATA17	DATA19	DATA21	DATA23	DATA0	DATA2	DATA4	DATA6	OE	BR	BG	EMIOS1	EMIOS5	EMIOS9	EMIOS13	EMIOS16	EMIOS19	EMIOS23	CNRXA	VDDE5	CLKOUT	VSS	VDD	AE	
AF	VSS	VDD	DATA16	DATA18	VDDE2	DATA20	DATA22	GPIO206	DATA1	DATA3	VDDE2	DATA5	DATA7	BB	EMIOS0	EMIOS4	EMIOS7	EMIOS11	EMIOS14	EMIOS18	EMIOS20	CNTXB	CNRXB	VDDE5	ENG_CLK	VSS	AF	

Note: NC No connect. AC22 & AD23 reserved

Figure 34. MPC5553 416 Package

	1	2	3	4	5	6	7	8	9	10	11	12	13
A	VSS	VSTBY	AN37	AN11	VDDA1	AN16	AN1	AN5	VRH	AN23	AN27	AN28	AN35
B	VDD	VSS	AN36	AN39	AN19	AN20	AN0	AN4	REF BYPC	AN22	AN26	AN31	AN32
C	VDD33	VDD	VSS	AN8	AN17	VSSA1	AN21	AN3	AN7	VRL	AN25	AN30	AN33
D	ETPUA 30	ETPUA 31	VDD	VSS	AN38	AN9	AN10	AN18	AN2	AN6	AN24	AN29	AN34
E	ETPUA 28	ETPUA 29	VDDEH 1	VDD									
F	ETPUA 24	ETPUA 27	ETPUA 26	VDDEH 1									
G	ETPUA 23	ETPUA 22	ETPUA 25	ETPUA 21									
H	ETPUA 20	ETPUA 19	ETPUA 18	ETPUA 17									
J	ETPUA 16	ETPUA 15	ETPUA 14	ETPUA 13									
K	ETPUA 12	ETPUA 11	ETPUA 10	ETPUA 9						VSS	VSS	VSS	VSS
L	ETPUA 8	ETPUA 7	ETPUA 6	ETPUA 5						VSS	VSS	VSS	VSS
M	ETPUA 4	ETPUA 3	ETPUA 2	ETPUA 1						VDDE2	VDDE2	VSS	VSS
N	BDIP	TEA	ETPUA 0	TCRCLK A						VDDE2	VDDE2	VSS	VSS
P	CS3	CS2	CS1	CS0						VDDE2	VDDE2	VSS	VSS
R	WE3	WE2	WE1	WE0						VDDE2	VDDE2	VSS	VSS
T	VDDE2	TSIZ0	RD_WR	VDDE2						VDDE2	VSS	VDDE2	VDDE2
U	ADDR 16	TSIZ1	TA	VDD33						VSS	VDDE2	VDDE2	VDDE2
V	ADDR 18	ADDR 17	TS	ADDR 8									
W	ADDR 20	ADDR 19	ADDR 9	ADDR 10									
Y	ADDR 22	ADDR 21	ADDR 11	VDDE2									
AA	ADDR 24	ADDR 23	ADDR 13	ADDR 12									
AB	VDDE2	ADDR 25	ADDR 15	ADDR 14									
AC	ADDR 26	ADDR 27	ADDR 31	VSS	VDD	DATA 26	DATA 28	VDDE2	DATA 30	DATA 31	DATA 8	DATA 10	VDDE2
AD	ADDR 28	ADDR 30	VSS	VDD	DATA 24	DATA 25	DATA 27	DATA 29	VDD33	GPIO 207	DATA 9	DATA 11	DATA 13
AE	ADDR 29	VSS	VDD	DATA 17	DATA 19	DATA 21	DATA 23	DATA 0	DATA 2	DATA 4	DATA 6	OE	BR
AF	VSS	VDD	DATA 16	DATA 18	VDDE2	DATA 20	DATA 22	GPIO 206	DATA 1	DATA 3	VDDE2	DATA 5	DATA 7

Figure 35. MPC5553 416 Package Left Side (view 1 of 2)

Mechanicals

14	15	16	17	18	19	20	21	22	23	24	25	26	
VSSA0	AN15	ETRIG 1	ETPUB 18	ETPUB 20	ETPUB 24	ETPUB 27	GPIO 205	MDO11	MDO8	VDD	VDD33	VSS	A
VSSA0	AN14	ETRIG 0	ETPUB 21	ETPUB 25	ETPUB 28	ETPUB 31	MDO10	MDO7	MDO4	MDO0	VSS	VDDE7	B
VDDA0	AN13	ETPUB 19	ETPUB 22	ETPUB 26	ETPUB 30	MDO9	MDO6	MDO3	MDO1	VSS	VDDE7	VDD	C
VDDEH 9	AN12	ETPUB 16	ETPUB 17	ETPUB 23	ETPUB 29	MDO5	MDO2	VDDEH 8	VSS	VDDE7	TCK	TDI	D
									VDDE7	TMS	TDO	TEST	E
									MSE00	JCOMP	EVTI	EVTO	F
									MSE01	MCKO	GPIO 204	ETPUB 15	G
									RDY	GPIO 203	ETPUB 14	ETPUB 13	H
									VDDEH 6	ETPUB 12	ETPUB 11	ETPUB 9	J
VDDE7	VDDE7	VDDE7	VDDE7						ETPUB 10	ETPUB 8	ETPUB 7	ETPUB 5	K
VSS	VSS	VSS	VDDE7						ETPUB 6	ETPUB 4	ETPUB 3	ETPUB 2	L
VSS	VSS	VSS	VDDE7						TCRCLK B	ETPUB 1	ETPUB 0	SINB	M
VSS	VSS	VSS	VDDE7						SOUTB	PCSB3	PCSB0	PCSB1	N
VSS	VSS	VSS	VSS						PCSA3	PCSB4	SCKB	PCSB2	P
VSS	VSS	VSS	VSS						PCSB5	SOUTA	SINA	SCKA	R
VDDE2	VDDE2	VSS	VSS						PCSA1	PCSA0	PCSA2	VPP	T
VDDE2	VDDE2	VSS	VSS						PCSA4	TXDA	PCSA5	VFLASH	U
									CNTXC	RXDA	RSTOUT	RST CFG	V
									RXDB	CNRXC	TXDB	RESET	W
									WKP CFG	BOOT CFG1	VRC VSS	VSS SYN	Y
									VDDEH 6	PLL CFG1	BOOT CFG0	EXTAL	AA
									VDD	VRC CTL	PLL CFG0	XTAL	AB
DATA 12	DATA 14	EMIOS 2	EMIOS 8	EMIOS 12	EMIOS 21	VDDEH 4	VDDE5	NC	VSS	VDD	VRC33	VDD SYN	AC
DATA 15	EMIOS 3	EMIOS 6	EMIOS 10	EMIOS 15	EMIOS 17	EMIOS 22	CNTXA	VDDE5	NC	VSS	VDD	VDD33	AD
BG	EMIOS 1	EMIOS 5	EMIOS 9	EMIOS 13	EMIOS 16	EMIOS 19	EMIOS 23	CNRXA	VDDE5	CLKOUT	VSS	VDD	AE
BB	EMIOS 0	EMIOS 4	EMIOS 7	EMIOS 11	EMIOS 14	EMIOS 18	EMIOS 20	CNTXB	CNRXB	VDDE5	ENG CLK	VSS	AF
14	15	16	17	18	19	20	21	22	23	24	25	26	

Note: NC No connect. AC22 & AD23 reserved

Figure 36. MPC5553 416 Package Right Side (view 2 of 2)

4.4 MPC5553 208-Pin Package Dimensions

The package drawings of the MPC5553 208-pin MAP BGA are shown in Figure 37.

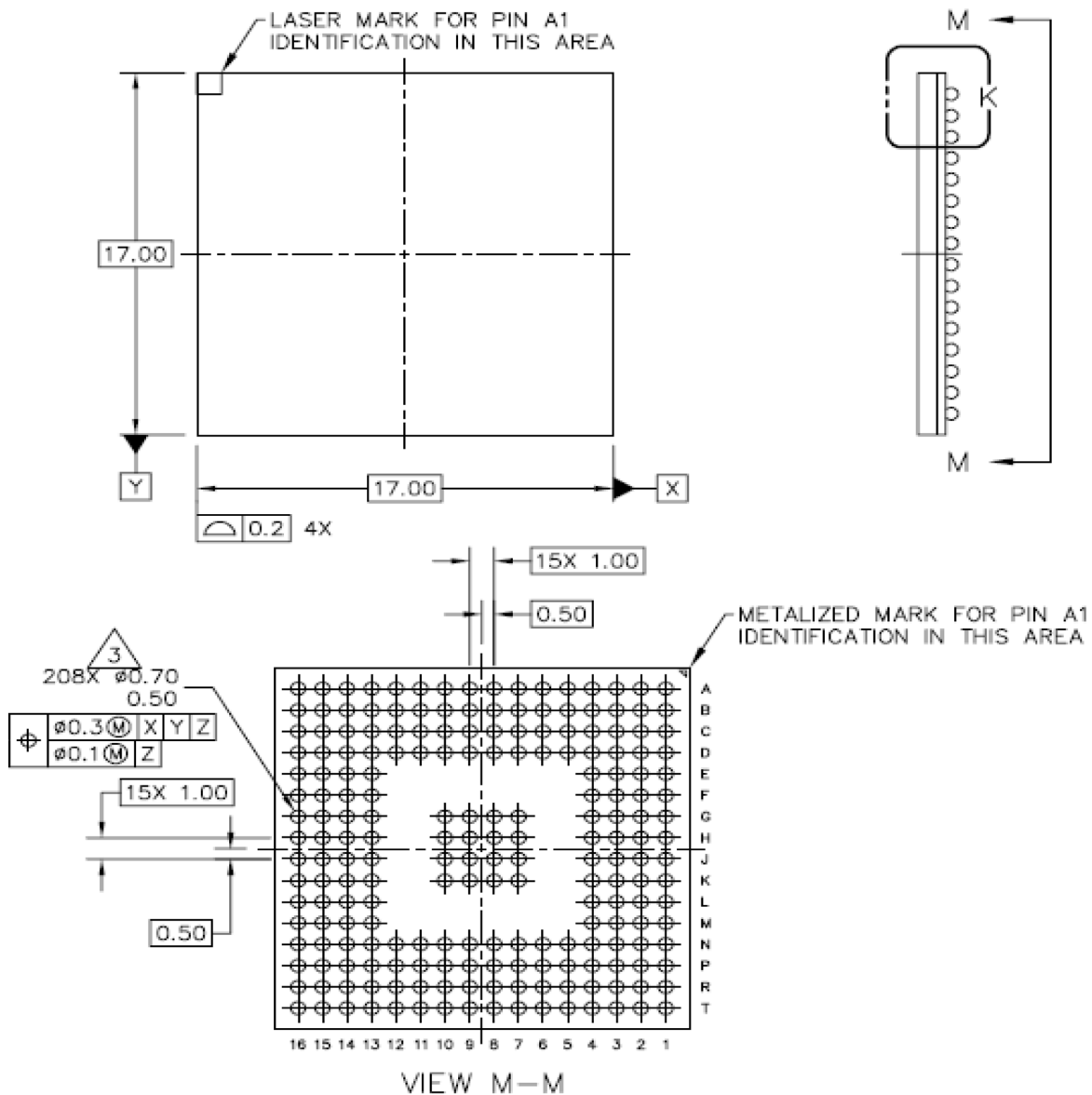

© FREESCALE SEMICONDUCTOR, INC. ALL RIGHTS RESERVED.	MECHANICAL OUTLINE	PRINT VERSION NOT TO SCALE	
TITLE: 208 I/O MAP BGA, 17 X 17 PKG, 1-MM PITCH	DOCUMENT NO: 98ARS23882W		REV: D
	CASE NUMBER: 1159A-01		02 AUG 2005
	STANDARD: JEDEC MO-151 AAF-1		

Figure 37. MPC5553 208-Pin Package

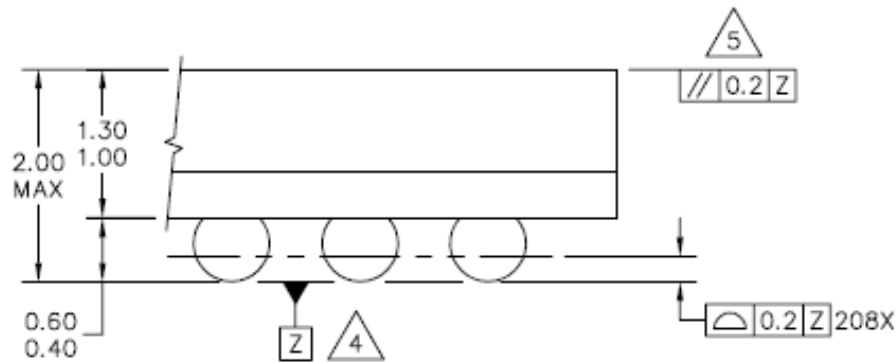
Mechanicals

DETAIL K
(ROTATED 90° CLOCKWISE)

NOTES:

1. ALL DIMENSIONS ARE IN MILLIMETERS.
2. INTERPRET DIMENSIONS AND TOLERANCES PER ASME Y14.5M-1994.
3. DIMENSION *b* IS MEASURED AT THE MAXIMUM SOLDER BALL DIAMETER, PARALLEL TO DATUM PLANE Z.
4. DATUM Z (SEATING PLANE) IS DEFINED BY THE SPHERICAL CROWNS OF THE SOLDER BALLS.
5. PARALLELISM MEASUREMENT SHALL EXCLUDE ANY EFFECT OF MARK ON TOP SURFACE OF PACKAGE.

© FREESCALE SEMICONDUCTOR, INC. ALL RIGHTS RESERVED.	MECHANICAL OUTLINE	PRINT VERSION NOT TO SCALE	
TITLE: 208 I/O MAP BGA, 17 X 17 PKG, 1-MM PITCH	DOCUMENT NO: 98ARS23882W	REV: D	
	CASE NUMBER: 1159A-01	02 AUG 2005	
	STANDARD: JEDEC MO-151 AAF-1		

Figure 37. MPC5553 208 MAP BGA Package (continued)

Mechanicals

NOTES:

1. ALL DIMENSIONS IN MILLIMETERS.
2. DIMENSIONING AND TOLERANCING PER ASME Y14.5M-1994.
3. MAXIMUM SOLDER BALL DIAMETER MEASURED PARALLEL TO DATUM A.
4. DATUM A, THE SEATING PLANE, IS DETERMINED BY THE SPHERICAL CROWNS OF THE SOLDER BALLS.
5. PARALLELISM MEASUREMENT SHALL EXCLUDE ANY EFFECT OF MARK ON TOP SURFACE OF PACKAGE.

© FREESCALE SEMICONDUCTOR, INC. ALL RIGHTS RESERVED.	MECHANICAL OUTLINE	PRINT VERSION NOT TO SCALE	
TITLE: PBGA, 324 I/O, 23 X 23 PKG, 1 MM PITCH (OMPAC)	DOCUMENT NO: 98ASS23840W	REV: D	
	CASE NUMBER: 1158-03	26 APR 2006	
	STANDARD: JEDEC MS-034 AAJ-1		

Figure 38. MPC5553 324 TEPBGA Package (continued)

4.6 MPC5553 416-Pin Package Dimensions

The package drawings of the MPC5553 416 pin TEPBGA package are shown in Figure 39.

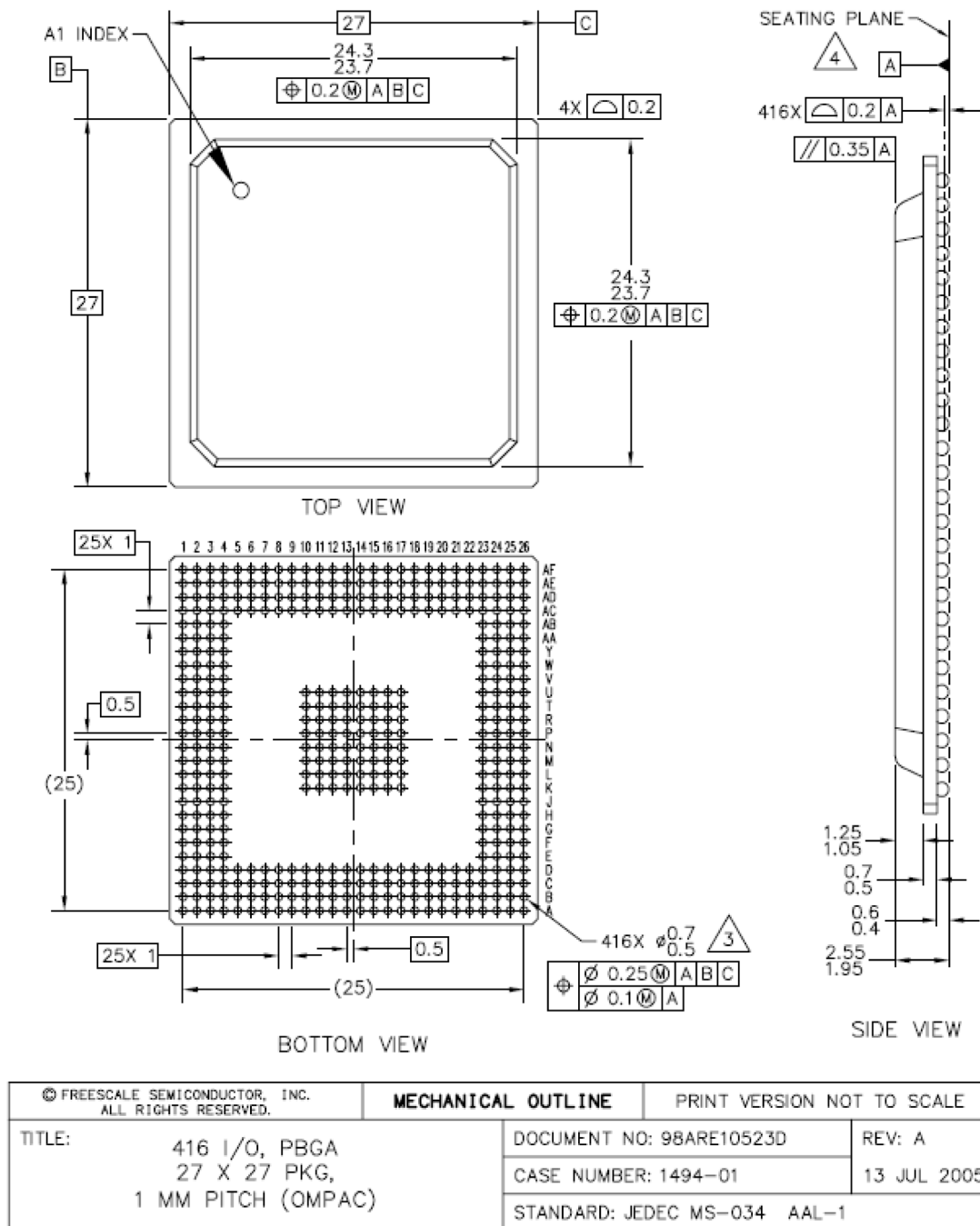



Figure 39. MPC5553 416 TEPBGA Package

Mechanicals

NOTES:

1. ALL DIMENSIONS IN MILLIMETERS.
2. DIMENSIONING AND TOLERANCING PER ASME Y14.5M-1994.
3.  MAXIMUM SOLDER BALL DIAMETER MEASURED PARALLEL TO DATUM A.
4.  DATUM A, THE SEATING PLANE, IS DETERMINED BY THE SPHERICAL CROWNS OF THE SOLDER BALLS.

© FREESCALE SEMICONDUCTOR, INC. ALL RIGHTS RESERVED.		MECHANICAL OUTLINE		PRINT VERSION NOT TO SCALE	
TITLE: 416 I/O, PBGA 27 X 27 PKG, 1 MM PITCH (OMPAC)	DOCUMENT NO: 98ARE10523D		REV: A		
	CASE NUMBER: 1494-01		13 JUL 2005		
	STANDARD: JEDEC MS-034 AAL-1				

Figure 39. MPC5553 416 TEPBGA Package (continued)

5 Revision History for the MPC5553 Data Sheet

The history of revisions made to this data sheet are described in this section. The changes are divided into each revision of this document.

The substantive changes incorporated in MPC5553 Data Sheet Rev. 3.0 to produce Rev. 4.0 are:

- Global and text changes
- Table and figure changes

Within each group, the changes are listed in sequential page number order.

5.1 Information Changed Between Revisions 3.0 and 4.0

Section 3.7, “Power-Up/Down Sequencing	<p>Added the following paragraph in Section 3.7, “Power-Up/Down Sequencing. “During initial power ramp-up, when V_{stby} is 0.6v or above, a typical current of 1-3mA and maximum of 4mA may be seen until VDD is applied. This current will not reoccur until V_{stby} is lowered below V_{stby} min specification”.</p> <p>Moved Figure 2 (f1STBY Worst-case Specifications) “ISTBY Worst-case Specifications” to Section 3.7, “Power-Up/Down Sequencing</p>
Section 3.8, “DC Electrical Specifications	<p>Removed the footnote “Figure 3 shows an illustration of the IDD_STBY values interpolated for these temperature values”.</p> <p>Modified the footnote attached to “the footnote attached to IDD_STBY” to “The current specification relates to average standby operation after SRAM has been loaded with data. For power up current see Section 3.7, “Power-Up/Down Sequencing”, Figure 2 (f1STBY Worst-case Specifications).”</p> <p>In Table 9 (DC Electrical Specifications ($T_A = T_L$ to T_H)) parameter 27d changed “Refer to Figure 2 for an interpolation of this data” to “RAM standby current”.</p>

5.2 Information Changed Between Revisions 2.0 and 3.0

The following table lists the global changes incorporated throughout the document, and substantive text changes made to paragraphs.

Table 32. Global and Text Changes Between Rev. 2.0 and 3.0

Location	Description of Change
<i>Global Changes</i>	
	<p>Starting at the third paragraph and throughout the document, replaced:</p> <ul style="list-style-type: none"> • kilobytes with KB • megabytes with MB • Changed $\overline{WE}[0:1]/\overline{BE}[0:1]$ to $\overline{WE}/\overline{BE}[0:1]$. • First paragraph, text changed from “based on the PowerPC Book E architecture” to “built on the Power Architecture embedded technology.” • Second paragraph: Changed terminology from PowerPC Book E architecture to Power Architecture terminology. • Put overbars on the following signals: \overline{BDIP}, \overline{OE}, \overline{TA}, \overline{TS}, \overline{TEA}

Revision History for the MPC5553 Data Sheet

Table 32. Global and Text Changes Between Rev. 2.0 and 3.0 (continued)

Location	Description of Change
Section 1, "Overview":	<ul style="list-style-type: none"> Added the sentence directly preceding Table 1: 'Unless noted in this data sheet, all specifications apply from T_L to T_H.' First paragraph, text changed from "based on the PowerPC Book E architecture" to "built on the Power Architecture embedded technology." Second paragraph: Changed terminology from PowerPC Book E architecture to Power Architecture terminology.
3.7.1, 3.7.2 and 3.7.3: Reordered sections resulting in the following order and section renumbering:	<ul style="list-style-type: none"> Section 3.7.1, "Input Value of Pins During POR Dependent on VDD33," then Section 3.7.2, "Power-Up Sequence (VRC33 Grounded)," then Section 3.7.3, "Power-Down Sequence (VRC33 Grounded)."
Section 3.7.1, "Input Value of Pins During POR Dependent on VDD33," changed:	<p>From:</p> <p>'To avoid accidentally selecting the bypass clock because PLLCFG[0:1] and RSTCFG are not treated as ones (1s) when POR negates, V_{DD33} must not lag V_{DDSYN} and the \overline{RESET} pin power (V_{DDEH6}) when powering the device by more than the V_{DD33} lag specification in Table 6 (V_{RC} and POR Electrical Specifications). V_{DD33} individually can lag either V_{DDSYN} or the \overline{RESET} power pin (V_{DDEH6}) by more than the V_{DD33} lag specification. V_{DD33} can lag one of the V_{DDSYN} or V_{DDEH6} supplies, but cannot lag both by more than the V_{DD33} lag specification. This V_{DD33} lag specification only applies during power up. V_{DD33} has no lead or lag requirements when powering down.'</p> <p>To:</p> <p>'When powering the device, V_{DD33} must not lag V_{DDSYN} and the \overline{RESET} power pin (V_{DDEH6}) by more than the V_{DD33} lag specification listed in Table 6 (V_{RC} and POR Electrical Specifications). This avoids accidentally selecting the bypass clock mode because the internal versions of PLLCFG[0:1] and RSTCFG are not powered and therefore cannot read the default state when POR negates. V_{DD33} can lag V_{DDSYN} or the \overline{RESET} power pin (V_{DDEH6}), but cannot lag both by more than the V_{DD33} lag specification. This V_{DD33} lag specification only applies during power up. V_{DD33} has no lead or lag requirements when powering down.'</p> <p>Added the following text directly before this section and after Table 8 (Pin Status for Medium and Slow Pads During the Power Sequence) <i>Pin Status for Medium / Slow Pads During the Power-on Sequence</i>:</p> <p>'The values in Table 7 (Pin Status for Fast Pads During the Power Sequence) and Table 8 (Pin Status for Medium and Slow Pads During the Power Sequence) do not include the effect of the weak pull devices on the output pins during power up.</p> <p>Before exiting the internal POR state, the voltage on the pins goes to high-impedance until POR negates. When the internal POR negates, the functional state of the signal during reset applies and the weak pull devices (up or down) are enabled as defined in the device <i>Reference Manual</i>. If V_{DD} is too low to correctly propagate the logic signals, the weak-pull devices can pull the signals to V_{DDE} and V_{DDEH}.</p> <p>To avoid this condition, minimize the ramp time of the V_{DD} supply to a time period less than the time required to enable the external circuitry connected to the device outputs.'</p>

The following table describes the changes made to information in tables and figures, and is presented in sequential page number order.

Table 33. Table and Figure Changes Between Rev. 2.0 and 3.0

Location	Description of Changes						
<i>Figure 1 MPC5500 Family Part Numbers:</i>							
	<ul style="list-style-type: none"> Removed the 2 in the tape and reel designator in both the graphic and in the Tape and Reel Status text. Changed Qualification Status by adding ‘, general market flow’ to the M designator, and added an ‘S’ designator with the description of ‘Fully spec. qualified, automotive flow.’ 						
<i>Table 1 (Orderable Part Numbers) Orderable Part Numbers:</i>							
	<ul style="list-style-type: none"> Moved the ‘Lead-free’ or ‘Lead’ in the Package Description column to a second line and added ‘Pb-free’ and ‘SnPb’ respectively. Changed Lead to Leaded. Footnote 2 changed to read: ‘The lowest ambient operating temperature is referenced by T_L; the highest ambient operating temperature is referenced by T_H.’ Footnote 3 changed to read: ‘Speed is the nominal maximum frequency. Max speed is the maximum speed allowed including frequency modulation (FM): 82 MHz parts allow for 80 MHz system clock + 2% FM; 114 MHz parts allow for 112 MHz system clock + 2% FM; and 132 MHz parts allow for 128 MHz system clock + 2% FM.’ 						
<i>Table 2 (Absolute Maximum Ratings) Absolute Maximum Ratings:</i>							
	<ul style="list-style-type: none"> Deleted Spec 3, “Flash core voltage.” Spec 21, Added the name of the spec, ‘V_{RC33} to V_{DDSYN} differential voltage,’ as well as the name and cross reference to Table 9, DC Electrical Specifications, to which the Spec was moved. Spec 28 “Maximum Solder Temperature”: Added two lines: Lead-free (Pb-free) and Leaded (SnPb) with maximum values of 260 C and 245 C respectively. Footnote 1, added: ‘any of’ between ‘beyond’ and ‘the listed maxima.’ Deleted footnote 2: ‘Absolute maximum voltages are currently maximum burn-in voltages. Absolute maximum specifications for device stress have not yet been determined.’ Footnote 6 (now footnote 5): Changed to the following sentence to the end, “Internal structures hold the input voltage greater than -1.0 V if the injection current limit of 2 mA is met. Keep the negative DC voltage greater than -0.6 V on eTPU[15] and on SINB during the internal power-on reset (POR) state.” 						
<i>Table 4 (EMI Testing Specifications) EMI Testing Specifications:</i> Changed the maximum operating frequency to from 132 to f_{MAX} .							
<i>Table 5 (ESD Ratings) ESD Characteristics:</i> Added (Electromagnetic Static Discharge) in the section title.							
<i>Table 6 (V_{RC} and POR Electrical Specifications), VCR/POR Electrical Specifications:</i>							
	<ul style="list-style-type: none"> Subscript all symbol names that appear after the first underscore character. Removed ‘Tj’ after ‘150 C’ in the last line, second column: Characteristic. Reformatted columns. Added footnote 1 to specs 1, 2, and 3 that reads: On power up, assert \overline{RESET} before V_{POR15}, V_{POR33}, and V_{POR5} negate (internal POR). RESET must remain asserted until the power supplies are within the operating conditions as specified in Table 9 (DC Electrical Specifications ($T_A = T_L$ to T_H)) DC Electrical Specifications. On power down, assert RESET before any power supplies fall outside the operating conditions and until the internal POR asserts. Added to Spec 2: <table style="margin-left: 20px; border-collapse: collapse;"> <tr> <td style="padding-right: 20px;">3.3 V (V_{DDSYN}) POR negated (ramp down)</td> <td style="padding-right: 20px;">Min. 0.0</td> <td>Max 0.30 V</td> </tr> <tr> <td>3.3 V (V_{DDSYN}) POR asserted (ramp up)</td> <td>Min. 0.0</td> <td>Max 0.30 V</td> </tr> </table> Specs 7 and 10: added ‘at Tj’ at the end of the first line in the second column: Characteristic. Spec 10: <ul style="list-style-type: none"> Changed the minimum values of: -40 C = 40; 25 C = 45; 150 C = 55. Added cross-reference to footnote 6: ‘I_{VRCCTL} is measured at the following conditions: $V_{DD} = 1.35$ V, $V_{RC33} = 3.1$ V, $V_{VRCCTL} = 2.2$ V.’ Changed ‘(@ $V_{DD} = 1.35$ V, $f_{SYS} = f_{MAX}$)’ to ‘(@ $f_{SYS} = f_{MAX}$)’. Added a new footnote 7, ‘Refer to Table 1 (Orderable Part Numbers) for the maximum operating frequency.’ Rewrote old footnote 8 (new footnote 9) to read: Represents the worst-case external transistor BETA. It is measured on a per-part basis and calculated as $(I_{DD} \div I_{VRCCTL})$. Deleted old footnote 9: ‘Preliminary value. Final specification pending characterization.’ 	3.3 V (V_{DDSYN}) POR negated (ramp down)	Min. 0.0	Max 0.30 V	3.3 V (V_{DDSYN}) POR asserted (ramp up)	Min. 0.0	Max 0.30 V
3.3 V (V_{DDSYN}) POR negated (ramp down)	Min. 0.0	Max 0.30 V					
3.3 V (V_{DDSYN}) POR asserted (ramp up)	Min. 0.0	Max 0.30 V					

Revision History for the MPC5553 Data Sheet

Table 33. Table and Figure Changes Between Rev. 2.0 and 3.0 (continued)

Location	Description of Changes
Table 7 (Pin Status for Fast Pads During the Power Sequence) <i>Power Sequence Pin Status for Fast Pads</i>	<ul style="list-style-type: none"> • Changed title to <i>Pin Status for Fast Pads During the Power Sequence</i> • Changed preceding paragraph <p style="margin-left: 20px;">From: Although there are no power up/down sequencing requirements to prevent issues like latch-up, excessive current spikes, etc., the state of the I/O pins during power up/down varies depending on power. Prior to exiting POR, the pads are in a high impedance state (Hi-Z).</p> <p style="margin-left: 20px;">To: There are no power up/down sequencing requirements to prevent issues such as latch-up, excessive current spikes, and so on. Therefore, the state of the I/O pins during power up/down varies depending on which supplies are powered.</p>
Table 8 (Pin Status for Medium and Slow Pads During the Power Sequence) <i>Power Sequence Pin Status for Medium/Slow Pads:</i>	<ul style="list-style-type: none"> • Changed title to <i>Pin Status for Medium and Slow Pads During the Power Sequence</i> • Updated preceding paragraph.
Table 9 (DC Electrical Specifications ($T_A = T_L$ to T_H)) <i>DC Electrical Specifications:</i>	<ul style="list-style-type: none"> • Spelled the slash '/' as 'and' as well as 'I/O' as 'input/output.' Still very confusing. Deleted 'input/output'. • Added footnote that reads: V_{DDE2} and V_{DDE3} are limited to 2.25–3.6 V only if EBTS = 0; V_{DDE2} and V_{DDE3} have a range of 1.6–3.6 V if EBTS = 1. • Spec 20, column 2, <i>Characteristics</i>, 'Slow and medium output high voltage ($I_{OH_S} = -2.0$ mA):' Created a left-justified second line and moved '$I_{OH_S} = -2.0$ mA' from the 1st line to the second line and deleted the parentheses. Created a left-justified third line that reads '$I_{OH_S} = -1.0$ mA.' • Spec 20, column 4, <i>Min.</i>: Added a blank line before and after '$0.80 \times V_{DDEH}$' and put '$0.85 \times V_{DDEH}$' on the last line. • Spec 22, column 2, 'Slow and medium output low voltage ($I_{OL_S} = 2.0$ mA):' Created a left-justified second line and moved '$I_{OL_S} = 2.0$ mA.' from the 1st line to the second line and deleted the parentheses. Created a left-justified third line that reads '$I_{OL_S} = 1.0$ mA.' Column 5, <i>Max</i>: Added a blank line before and after '$0.20 \times V_{DDEH}$' and put '$0.15 \times V_{DDEH}$' on the last line. • Spec 26: Changed 'AN[12]_MA[1]_SDO' to 'AN[13]_MA[1]_SDO'. • Spec 27a: Operating current 1.5 V supplies @ 132 MHz changed to: <ul style="list-style-type: none"> 1.65 typical = 460 1.35 typical = 360 1.65 high = 510 1.35 high = 410 • Spec 27b, Operating current 1.5 V supplies @ 114 MHz changed to: <ul style="list-style-type: none"> 1.65 typical = 410 1.35 typical = 310 1.65 high = 460 1.35 high = 370 • Spec 27c, Operating current 1.5 V supplies @ 82 MHz changed to: <ul style="list-style-type: none"> 1.65 typical = 330 1.35 typical = 225 1.65 high = 385 1.35 high = 290 • Spec 28: Changed 132 MHz to f_{MAX} MHz. • Footnote 3 changed to read: If standby operation is not required, connect V_{STBY} to ground. • Footnote 6 is now: Figure 3 (Power-Up Sequence (VRC33 Grounded)) shows an illustration of the IDD_STBY values interpolated for these temperature values. • Deleted footnote 9: 'Preliminary. Final specification pending characterization.' • Deleted duplicate footnote: 'Absolute value of current, measured at V_{IL} and V_{IH}.'

Table 33. Table and Figure Changes Between Rev. 2.0 and 3.0 (continued)

Location	Description of Changes
Table 10 (I/O Pad Average DC Current ($T_A = T_L$ to T_H))	I/O Pad Average DC Current : Added ($T_A = T_L - T_H$)
Table 11 (VDD33 Pad Average DC Current ($T_A = T_L$ to T_H))	VDD33 Pad Average DC Current : Added ($T_A = T_L - T_H$)
Table 12 (FMPLL Electrical Specifications)	FMPLL Electrical Characteristics : <ul style="list-style-type: none"> • Spec 1, footnote 1 in column 2: ‘PLL reference frequency range’: Added that reads ‘Nominal crystal and external reference values are worst-case not more than 1%. The device operates correctly if the frequency remains within $\pm 5\%$ of the specification limit. This tolerance range allows for a slight frequency drift of the crystals over time. The designer must thoroughly understand the drift margin of the source clock.’ • Spec 21, column 2: Changed $f_{ref_crystal}$ to f_{ref} in ICO frequency equation, and added the same equation but substituted f_{ref_ext} for f_{ref} for the external reference clock, giving: $f_{ico} = [f_{ref_crystal} \times (MFD + 4)] \div (PREDIV + 1)$ $f_{ico} = [f_{ref_ext} \times (MFD + 4)] \div (PREDIV + 1)$ • Spec 21: Changed column 5 from ‘f_{SYS} MHz’ to: ‘f_{MAX}’. • Spec 22: Changed column 4, <i>Max Value</i> from f_{MAX} to 20, and added footnote 17 to read, ‘Maximum value for dual controller (1:1) mode is ($f_{MAX} \div 2$) and the predivider set to 1 (FMPLL_SYNCR[PREDIV] = 0b001).’
Table 13 (eQADC Conversion Specifications ($T_A = T_L$ to T_H))	eQADC Conversion Specifications : Added ($T_A = T_L - T_H$) to the table title.
Table 14 (Flash Program and Erase Specifications ($T_A = T_L$ to T_H))	Flash Program and Erase Specifications : <ul style="list-style-type: none"> • Added ($T_A = T_L - T_H$) to the table title. • Specs 9 and 10: Changed typical values for the H7Fa Flash pre-program and erase times: <ul style="list-style-type: none"> -- 48 KB: from 435 to 345 -- 64 KB: from 525 to 415 • Spec 8, 128KB block pre-program and erase time: <ul style="list-style-type: none"> -- Typical column values from 675 to 500. -- Initial Max column from 1800 to 1250. -- Max column values from 15,000 to 7,500. • Moved footnote 1 from the table title to directly after the ‘Typical’ in the column 5 header. • Footnote 2: Changed from: ‘Initial factory condition: ≤ 100 program/erase cycles, 25 °C, typical supply voltage, 80 MHz minimum system frequency.’ To: ‘Initial factory condition: ≤ 100 program/erase cycles, 25 °C, using a typical supply voltage measured at a minimum system frequency of 80 MHz.’
Table 15 (Flash EEPROM Module Life ($T_A = T_L$ to T_H))	Flash EEPROM Module Life : <ul style="list-style-type: none"> • Replaced (Full Temperature Range) with ($T_A = T_L - T_H$) in the table title. • Spec 1b, Min. column value changed from 10,000 to 1,000.
Table 16 (FLASH_BIU Settings vs. Frequency of Operation)	FLASH_BIU Settings vs. Frequency of Operations : <ul style="list-style-type: none"> • ‘Added footnote 1 to the end of the table title, The footnote reads: ‘Illegal combinations exist. Use entries from the same row in this table.’ • Moved footnote 2: ‘For maximum flash performance, set to 0b11’ to the ‘DPFEN’ column header. • Deleted the x-refs in the ‘DPFEN’ column for the rows. • Created a x-ref for footnote 2 and inserted in the ‘IPFEN’ column header. • Deleted the x-refs in the ‘IPFEN’ column for the rows. • Moved footnote 3: ‘For maximum flash performance, set to 0b110’ to the ‘PFLIM’ column header. • Deleted the x-refs in the ‘PFLIM’ column for the rows. • Moved footnote 4: ‘For maximum flash performance, set to 0b1’ to the ‘BFEN’ column header. • Deleted the x-refs in the ‘BFEN’ column for the rows. • Changed footnotes 1, 5, and 6 to become footnotes 5, 6, and 7 <ul style="list-style-type: none"> -- footnote 5 82 MHz parts allow for 80 MHz system clock + 2% frequency modulation (FM). -- footnote 6 102 MHz parts allow for 100 MHz system clock + 2% FM. -- footnote 7 132 MHz parts allow for 128 MHz system clock + 2% FM.

Revision History for the MPC5553 Data Sheet

Table 33. Table and Figure Changes Between Rev. 2.0 and 3.0 (continued)

Location	Description of Changes
<p><i>Table 17 (Pad AC Specifications (VDDEH = 5.0 V, VDDE = 1.8 V)) Pad AC Specifications and Table 18 (Derated Pad AC Specifications (VDDEH = 3.3 V, VDDE = 3.3 V)) Derated Pad AC Specifications:</i> The changes are identical in the tables.</p>	<ul style="list-style-type: none"> • Table 17 Pad AC Specifications ONLY: Footnote 1, changed 'V_{DDEH} = 4.5–5.5;' to 'V_{DDEH} = 4.5–5.25;' • Footnote 1, deleted 'F_{SYS} = 132 MHz.' • Footnote 2, changed from 'tested' to '(not tested).' • Footnote 3, changed from 'Out delay' to 'The output delay', • Changed from 'Add a maximum of one system clock to the output delay to get the output delay with respect to the system clock'to 'To calculate the output delay with respect to the system clock, add a maximum of one system clock to the output delay.' • Footnote 4: changed 'Delay' to 'The output delay.' • Footnote 5: deleted 'before qualification.' Changed from 'This parameter is supplied for reference and is not guaranteed by design and not tested' to 'This parameter is supplied for reference and is guaranteed by design and tested.' • Changed from 'This parameter is supplied for reference and is not guaranteed by design and not tested' to 'This parameter is supplied for reference and is guaranteed by design and tested.'
<p><i>Table 19 (Reset and Configuration Pin Timing) Reset and Configuration Pin Timing:</i> Footnote 1, deleted 'F_{SYS} = 132 MHz.'</p>	
<p><i>Table 20 (JTAG Pin AC Electrical Characteristics) JTAG Pin AC Electrical Characteristics:</i></p>	<p>Footnote 1, deleted: 'and CL = 30 pF with DSC = 0b10, SRC = 0b11,' changed 'functional' to 'Nexus.'</p>
<p><i>Table 21 (Nexus Debug Port Timing) Nexus Debug Port Timing.</i></p>	<p>Changed Spec 12, TCK Low to TDO Data Valid: Changed 'VDDE = 3.0 to 3.6 volts' maximum value in column 4 from 9 to 10. Now reads 'V_{DDE} = 3.0–3.6 V' with a max value of 10.</p>
<p><i>Table 22 (Bus Operation Timing) Bus Operation Timing:</i></p>	<ul style="list-style-type: none"> • External Bus Frequency in the table heading: Added footnote that reads: Speed is the nominal maximum frequency. Max speed is the maximum speed allowed including frequency modulation (FM). 82 MHz parts allow for 80 MHz system clock + 2% FM; 114 MHz parts allow for 112 MHz system clock + 2% FM, and 132 MHz parts allow for 128 MHz system clock + 2% FM. • Spec 1: Changed the values in Min. columns: 40 MHz from 25 to 24.4; 56 MHz from 17.9 to 17.5 • Specs 7 and 8: Removed from external bus interface: $\overline{\text{BDIP}}$, $\overline{\text{OE}}$, $\overline{\text{WE}}/\overline{\text{BE}}[0:1]$; removed from the calibration bus interface $\overline{\text{CS}}[0, 2:3]$, $\overline{\text{CAL_WE}}/\overline{\text{BE}}[0:1]$. • Deleted duplicate footnote: The EBTS = 0 timings are tested and valid at V_{DDE} = 2.25–3.6 V only, whereas EBTS = 1 timings are tested and valid at V_{DDE} = 1.6–3.6 V. • Added a footnote each for the DATA[0:31], TEA, and $\overline{\text{WE}}/\overline{\text{BE}}[0:3]$ signals in the table: Due to pin limitations, the DATA[16:31], $\overline{\text{TEA}}$, and $\overline{\text{WE}}/\overline{\text{BE}}[2:3]$ signals are not available on the 324 package.
<p><i>Table 23 (External Interrupt Timing) External Interrupt Timing:</i></p>	<ul style="list-style-type: none"> • Footnote 1, changed 'V_{DDEH} = 4.5–5.5;' to 'V_{DDEH} = 4.5–5.25;' • Footnote 1: Deleted 'F_{SYS} = 132 MHz.', 'V_{DD} = 1.35–1.65 V', 'V_{DD33} and V_{DDSYN} = 3.0–3.6 V' and 'and CL = 200 pF with SRC = 0b11.' • Deleted second figure after table 'External Interrupt Setup Timing.'
<p><i>Table 24 (eTPU Timing) eTPU Timing</i></p>	<ul style="list-style-type: none"> • Footnote 1, changed 'V_{DDEH} = 4.5–5.5;' to 'V_{DDEH} = 4.5–5.25;' • Footnote 1: Deleted 'F_{SYS} = 132 MHz.', 'V_{DD} = 1.35–1.65 V', 'V_{DD33} and V_{DDSYN} = 3.0–3.6' and 'and CL = 200 pF with SRC = 0b11.' • Deleted second figure, 'eTPU Input/Output Timing' after this table. • Added Footnote 2: 'This specification does not include the rise and fall times. When calculating the minimum eTPU pulse width, include the rise and fall times defined in the slew rate control fields (SRC) of the pad configuration registers (PCR).'

Table 33. Table and Figure Changes Between Rev. 2.0 and 3.0 (continued)

Location	Description of Changes
<i>Table 25 (eMIOS Timing) eMIOS Timing:</i>	<ul style="list-style-type: none"> Deleted (MTS) from the heading, table, and footnotes. Footnote 1, changed 'V_{DDEH} = 4.5–5.5;' to 'V_{DDEH} = 4.5–5.25;' Footnote 1: Deleted 'F_{SYS} = 132 MHz', 'V_{DD} = 1.35–1.65 V', 'V_{DD33} and V_{DDSYN} = 3.0–3.6 V' and 'and CL = 200 pF with SRC = 0b11.' Added Footnote 2: 'This specification does not include the rise and fall times. When calculating the minimum eMIOS pulse width, include the rise and fall times defined in the slew rate control fields (SRC) of the pad configuration registers (PCR).'
<i>Figure 17 (eMIOS Timing) Added eMIOS Timing figure.</i>	
<i>Table 26 (DSPI Timing) DSPI Timing:</i>	<ul style="list-style-type: none"> Footnote 1, changed 'V_{DDEH} = 4.5–5.5;' to 'V_{DDEH} = 4.5–5.25;' Table Title: Added footnote that reads: Speed is the nominal maximum frequency. Max speed is the maximum speed allowed including frequency modulation (FM). 82 MHz parts allow for 80 MHz system clock + 2% FM; 114 MHz parts allow for 112 MHz system clock + 2% FM, and 132 MHz parts allow for 128 MHz system clock + 2% FM. Spec 1: SCK cycle time; Changed 80 MHz = 24.4, and 112 MHz = 17.5. Footnote 1: Changed to read: 'All DSPI timing specifications use the fastest slew rate (SRC = 0b11) on pad type M or MH. DSPI signals using pad types of S or SH have an additional delay based on the slew rate.' Deleted 'V_{DD} = 1.35–1.65 V' and 'V_{DD33} and V_{DDSYN} = 3.0–3.6 V.'
<i>Table 27 (EQADC SSI Timing Characteristics) EQADC SSI Timing Characteristics:</i>	<ul style="list-style-type: none"> Footnote 1, changed 'V_{DDEH} = 4.5–5.5;' to 'V_{DDEH} = 4.5–5.25;' Deleted from table title '(Pads at 3.3 V or 5.0 V)' Deleted 1st line in table 'CLOAD = 25 pF on all outputs. Pad drive strength set to maximum.' Spec 1: FCK frequency -- removed. Combined footnotes 1 and 2, and moved the new footnote to Spec 2. Moved old footnote 3 that is now footnote 2 to Spec 2. Footnote 1, deleted 'V_{DD} = 1.35–1.65 V' and 'V_{DD33} and V_{DDSYN} = 3.0–3.6V.' Changed 'CL = 50 pF' to 'CL = 25 pF.' Footnote 2: added 'cycle' after 'duty' to read: FCK duty cycle is not 50% when. . . .
<i>Section 3.14, "Fast Ethernet AC Timing Specifications": Figure 28 (MII FEC Receive Signal Timing Diagram), Figure 29 (MII FEC Transmit Signal Timing Diagram), Figure 30 (MII FEC Asynchronous Inputs Timing Diagram), and Figure 31 (MII FEC Serial Management Channel Timing Diagram).</i>	Removed the 'M' in the diagram labels that refer to the specification numbers.
<i>Figure 37 (MPC5553 208-Pin Package)MPC5553 208 Package:</i>	Deleted the version number and date.
<i>Figure 38 (MPC5553 324 TEPBGA Package)MPC5553 324 Package:</i>	Deleted the version number and date.
<i>Figure 39 (MPC5553 416 TEPBGA Package) and Figure 39 (MPC5553 416 TEPBGA Package (continued))MPC5553 416 Package:</i>	Deleted the version number and date.

How to Reach Us:**Home Page:**

www.freescale.com

Web Support:

<http://www.freescale.com/support>

USA/Europe or Locations Not Listed:

Freescale Semiconductor, Inc.
Technical Information Center, EL516
2100 East Elliot Road
Tempe, Arizona 85284
+1-800-521-6274 or +1-480-768-2130
www.freescale.com/support

Europe, Middle East, and Africa:

Freescale Halbleiter Deutschland GmbH
Technical Information Center
Schatzbogen 7
81829 Muenchen, Germany
+44 1296 380 456 (English)
+46 8 52200080 (English)
+49 89 92103 559 (German)
+33 1 69 35 48 48 (French)
www.freescale.com/support

Japan:

Freescale Semiconductor Japan Ltd.
Headquarters
ARCO Tower 15F
1-8-1, Shimo-Meguro, Meguro-ku,
Tokyo 153-0064
Japan
0120 191014 or +81 3 5437 9125
support.japan@freescale.com

Asia/Pacific:

Freescale Semiconductor China Ltd.
Exchange Building 23F
No. 118 Jianguo Road
Chaoyang District
Beijing 100022
China
+86 10 5879 8000
support.asia@freescale.com

For Literature Requests Only:

Freescale Semiconductor Literature Distribution Center
1-800-441-2447 or 303-675-2140
Fax: 303-675-2150
LDCForFreescaleSemiconductor@hibbertgroup.com

Information in this document is provided solely to enable system and software implementers to use Freescale Semiconductor products. There are no express or implied copyright licenses granted hereunder to design or fabricate any integrated circuits or integrated circuits based on the information in this document.

Freescale Semiconductor reserves the right to make changes without further notice to any products herein. Freescale Semiconductor makes no warranty, representation or guarantee regarding the suitability of its products for any particular purpose, nor does Freescale Semiconductor assume any liability arising out of the application or use of any product or circuit, and specifically disclaims any and all liability, including without limitation consequential or incidental damages. "Typical" parameters that may be provided in Freescale Semiconductor data sheets and/or specifications can and do vary in different applications and actual performance may vary over time. All operating parameters, including "Typicals", must be validated for each customer application by customer's technical experts. Freescale Semiconductor does not convey any license under its patent rights nor the rights of others. Freescale Semiconductor products are not designed, intended, or authorized for use as components in systems intended for surgical implant into the body, or other applications intended to support or sustain life, or for any other application in which the failure of the Freescale Semiconductor product could create a situation where personal injury or death may occur. Should Buyer purchase or use Freescale Semiconductor products for any such unintended or unauthorized application, Buyer shall indemnify and hold Freescale Semiconductor and its officers, employees, subsidiaries, affiliates, and distributors harmless against all claims, costs, damages, and expenses, and reasonable attorney fees arising out of, directly or indirectly, any claim of personal injury or death associated with such unintended or unauthorized use, even if such claim alleges that Freescale Semiconductor was negligent regarding the design or manufacture of the part.

Freescale™ and the Freescale logo are trademarks of Freescale Semiconductor, Inc. All other product or service names are the property of their respective owners.

© Freescale Semiconductor, Inc. 2008-2012. All rights reserved.

RoHS-compliant and/or Pb-free versions of Freescale products have the functionality and electrical characteristics as their non-RoHS-compliant and/or non-Pb-free counterparts. For further information, see <http://www.freescale.com> or contact your Freescale sales representative.

For information on Freescale's Environmental Products program, go to <http://www.freescale.com/epp>.

OUR CERTIFICATE

DiGi provide top-quality products and perfect service for customer worldwide through standardization, technological innovation and continuous improvement. DiGi through third-party certification, we stricly control the quality of products and services. Welcome your RFQ to

Email: Info@DiGi-Electronics.com



Tel: +00 852-30501935

RFQ Email: Info@DiGi-Electronics.com

DiGi is a global authorized distributor of electronic components.