

EE-SX1103 Datasheet

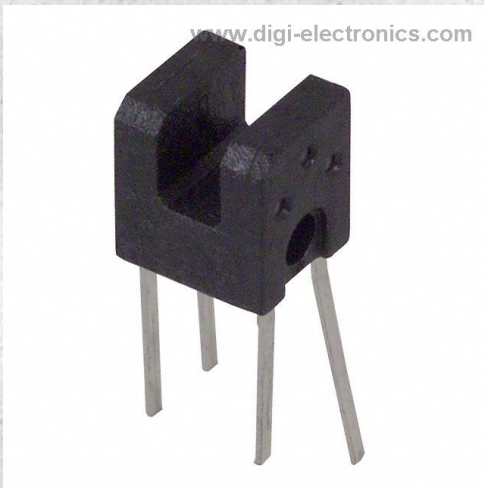

<https://www.DiGi-Electronics.com>

DiGi Electronics Part Number	EE-SX1103-DG
Manufacturer	Omron Electronics Inc-EMC Div
Manufacturer Product Number	EE-SX1103
Description	SENSOR OPT SLOT PHOTOTRAN PCB MT
Detailed Description	Optical Sensor Through-Beam 0.079" (2mm) Photo transistor PCB Mount

This model EE-SX1103 is available at DiGi Electronics.

DiGi Electronics offers a global database of semiconductor and electronic component datasheets.

We welcome your inquiries regarding pricing, lead time, or other product-related questions.

 [Request a Quote](#)

 [Datasheet Search](#)



Tel: +00 852-30501935

RFQ Email: Info@DiGi-Electronics.com

DiGi is a global authorized distributor of electronic components.

Purchase and inquiry

Manufacturer Product Number:

EE-SX1103

Series:

-

Sensing Distance:

0.079" (2mm)

Output Configuration:

Phototransistor

Current - Collector (Ic) (Max):

30 mA

Response Time:

10µs, 10µs

Mounting Type:

Through Hole

Type:

Unamplified

Manufacturer:

Omron Electronics Inc-EMC Div

Product Status:

Active

Sensing Method:

Through-Beam

Current - DC Forward (If) (Max):

50 mA

Voltage - Collector Emitter Breakdown (Max):

30 V

Operating Temperature:

-25°C ~ 85°C

Package / Case:

PCB Mount

Environmental & Export classification

RoHS Status:

ROHS3 Compliant

REACH Status:

REACH Unaffected

HTSUS:

8541.49.8000

Moisture Sensitivity Level (MSL):

Not Applicable

ECCN:

EAR99

Photomicrosensor (Transmissive)

EE-SX1103

Compact Slot/Terminal Type
(Slot Width: 2 mm)

- Low profile (Height: 5.2 mm) type
- Terminal for PCB mounting



⚠ Be sure to read *Safety Precautions* on Page 3.

RoHS Compliant

Ordering Information

Photomicrosensor

Appearance	Sensing method	Connecting method	Sensing distance	Aperture size (H × W) (mm)	Output type	Model	Minimum packing unit (Unit: pcs)
	Transmissive (slot type)	Terminal for PCB mounting	2 mm (Slot width)	Both emitting side and detecting side 1.2 × 0.4	Phototransistor	EE-SX1103	1

Note: Order in multiples of minimum packing unit.

Ratings, Characteristics and Exterior Specifications

Absolute Maximum Ratings (Ta = 25°C)

Item	Symbol	Rated value	Unit
Emitter			
Forward current	I _F	50*1	mA
Pulse forward current	I _{FP}	—	A
Reverse voltage	V _R	5	V
Detector			
Collector-Emitter voltage	V _{CEO}	30	V
Emitter-Collector voltage	V _{ECO}	4.5	V
Collector current	I _C	30	mA
Collector dissipation	P _C	80*1	mW
Operating temperature	T _{opr}	-25 to 85	°C
Storage temperature	T _{stg}	-30 to 100	°C
Soldering temperature	T _{sol}	260*2	°C

*1. Refer to the temperature rating chart if the ambient temperature exceeds 25°C.

*2. Complete soldering within 3 seconds.

Exterior Specifications

Connecting method	Weight (g)	Material	
		Case	Lens
Terminal for PCB mounting	0.2	PPS	Epoxy resin

Electrical and Optical Characteristics (Ta = 25°C)

Item	Symbol	Value			Unit	Condition
		MIN.	TYP.	MAX.		
Emitter						
Forward voltage	V _F	—	1.3	1.6	V	I _F = 50 mA
Reverse current	I _R	—	—	10	μA	V _R = 5 V
Peak emission wavelength	λ _P	—	950	—	nm	I _F = 50 mA
Detector						
Light current	I _L	0.5	—	—	mA	I _F = 20 mA, V _{CE} = 5 V
Dark current	I _D	—	—	500	nA	V _{CE} = 10 V, 0 lx
Leakage current	I _{LEAK}	—	—	—	μA	—
Collector-Emitter saturated voltage	V _{CE (sat)}	—	—	0.4	V	I _F = 20 mA, I _L = 0.3 mA
Peak spectral sensitivity wavelength	λ _P	—	800	—	nm	V _{CE} = 5 V
Rising time	t _r	—	10	—	μs	V _{CC} = 5 V, R _L = 100 Ω, I _F = 20 mA
Falling time	t _f	—	10	—	μs	V _{CC} = 5 V, R _L = 100 Ω, I _F = 20 mA

Engineering Data (Reference Value)

Fig 1. Forward Current vs. Collector Dissipation Temperature Rating

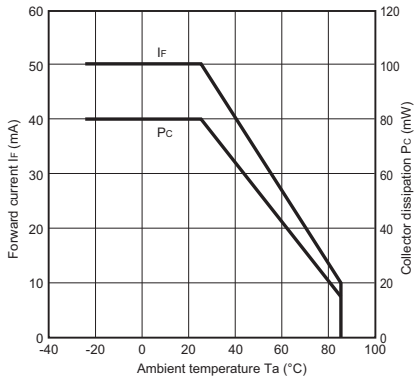

Fig 2. Forward Current vs. Forward Voltage Characteristics (Typical)

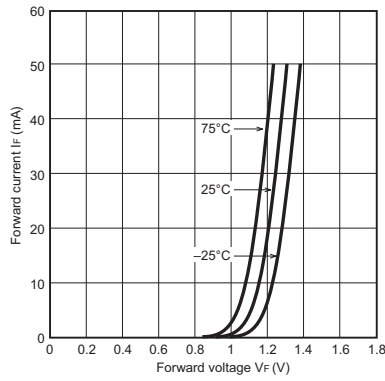

Fig 3. Light Current vs. Forward Current Characteristics (Typical)

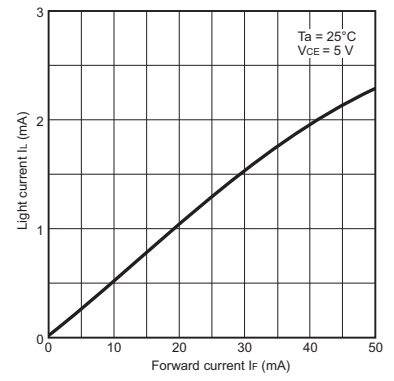

Fig 4. Light Current vs. Collector-Emitter Voltage Characteristics (Typical)

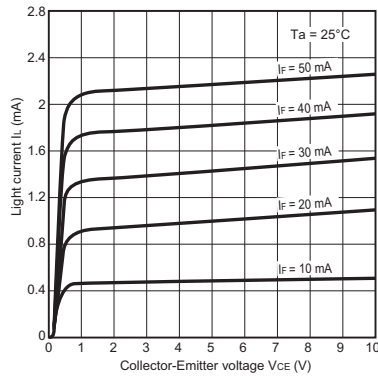

Fig 5. Relative Light Current vs. Ambient Temperature Characteristics (Typical)

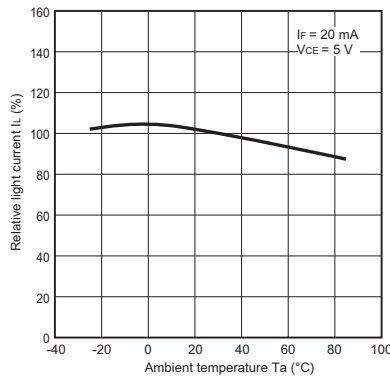

Fig 6. Dark Current vs. Ambient Temperature Characteristics (Typical)

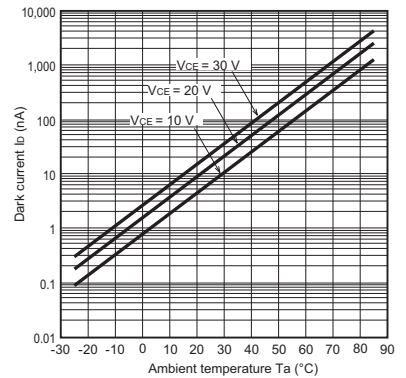

Fig 7. Response Time vs. Light Current Characteristics (Typical)

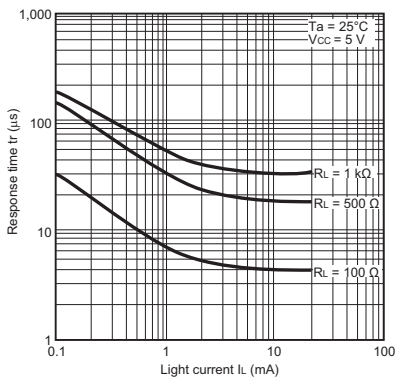

Fig 8. Sensing Position Characteristics (Typical)

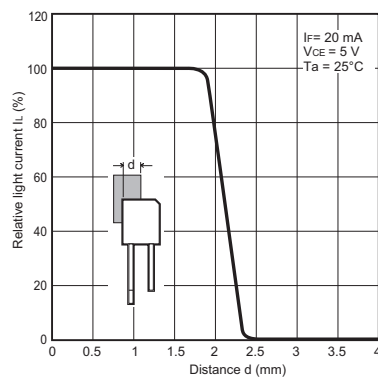

Fig 9. Sensing Position Characteristics (Typical)

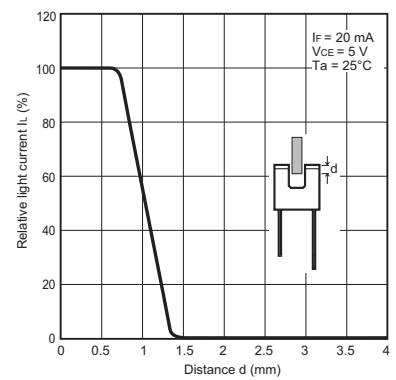
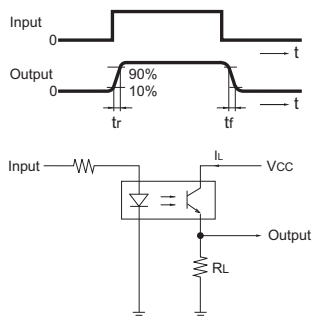

Fig 10. Response Time Measurement Circuit



Safety Precautions

To ensure safe operation, be sure to read and follow the Instruction Manual provided with the Sensor.

CAUTION

This product is not designed or rated for ensuring safety of persons either directly or indirectly. Do not use it for such purposes.



Precautions for Correct Use

Do not use the product in atmospheres or environments that exceed product ratings.

Precautions for Safe Use

Do not use the product with a voltage or current that exceeds the rated range.

Applying a voltage or current that is higher than the rated range may result in explosion or fire.

Do not miswire such as the polarity of the power supply voltage.

Otherwise the product may be damaged or it may burn.

This product does not resist water. Do not use the product in places where water or oil may be sprayed onto the product.

Dimensions and Internal Circuit

(Unit: mm)

Photomicrosensor

EE-SX1103



Aperture size (H x W)

Emitter	Detector
1.2 x 0.4	1.2 x 0.4

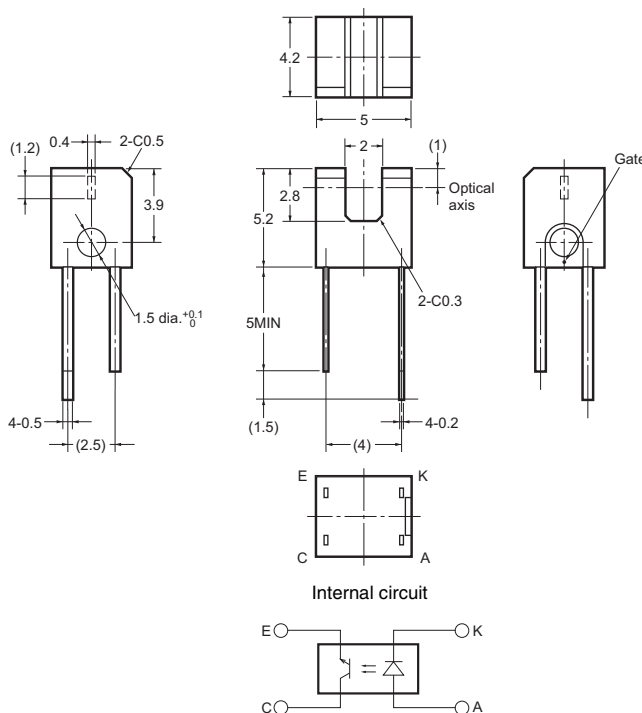

Terminal No.	Name
A	Anode
K	Cathode
C	Collector
E	Emitter

Note: 1. Unless otherwise specified, the tolerances are ±0.2 mm.
 2. Dimensions in parentheses are for reference only.
 3. Dimensions of the slit are those of the primary mold.

Please check each region's Terms & Conditions by region website.

OMRON Corporation

Electronic and Mechanical Components Company

Regional Contact

Americas

<https://www.components.omron.com/>

Asia-Pacific

<https://ecb.omron.com.sg/>

Korea

<https://www.omron-ecb.co.kr/>

Europe

<http://components.omron.eu/>

China

<https://www.ecb.omron.com.cn/>

Japan

<https://www.omron.co.jp/ecb/>

OUR CERTIFICATE

DiGi provide top-quality products and perfect service for customer worldwide through standardization, technological innovation and continuous improvement. DiGi through third-party certification, we stricly control the quality of products and services. Welcome your RFQ to

Email: Info@DiGi-Electronics.com



Tel: +00 852-30501935

RFQ Email: Info@DiGi-Electronics.com

DiGi is a global authorized distributor of electronic components.