

ELT-3KN032C Datasheet



DiGi Electronics Part Number	ELT-3KN032C-DG
Manufacturer	Panasonic Electronic Components
Manufacturer Product Number	ELT-3KN032C
Description	FIXED IND 25MH 10MA 185OHM SMD
Detailed Description	25 mH Unshielded Drum Core, Wirewound Inductor 10 mA 185Ohm Nonstandard

<https://www.DiGi-Electronics.com>

This model ELT-3KN032C is available at DiGi Electronics.

DiGi Electronics offers a global database of semiconductor and electronic component datasheets.

We welcome your inquiries regarding pricing, lead time, or other product-related questions.

 [Request a Quote](#)

 [Datasheet Search](#)



Tel: +00 852-30501935

RFQ Email: Info@DiGi-Electronics.com

DiGi is a global authorized distributor of electronic components.

Purchase and inquiry

Manufacturer Product Number:

ELT-3KN032C

Series:

ELT3KN

Type:

Drum Core, Wirewound

Inductance:

25 mH

Current Rating (Amps):

10 mA

Shielding:

Unshielded

Q @ Freq:

-

Ratings:

-

Features:

-

Package / Case:

Nonstandard

Size / Dimension:

0.130" L x 0.130" W (3.30mm x 3.30mm)

Base Product Number:

ELT-3KN

Manufacturer:

Panasonic Electronic Components

Product Status:

Last Time Buy

Material - Core:

Ferrite

Tolerance:

±40%

Current - Saturation (Isat):

-

DC Resistance (DCR):

1850hm

Frequency - Self Resonant:

-

Operating Temperature:

-20°C ~ 105°C

Mounting Type:

Surface Mount

Supplier Device Package:

-

Height - Seated (Max):

0.087" (2.20mm)

Environmental & Export classification

ECCN:

EAR99

HTSUS:

8504.50.8000

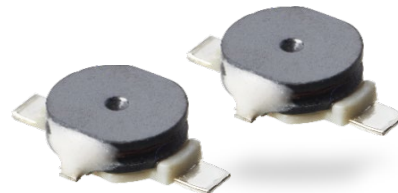

Voltage Step-up Coils

Chip type

ELT3KN series

High inductance Voltage Step-up coil chip series for piezoelectric buzzers and DC/DC circuitry of EL panels

Features

- Small and thin
- High inductance
- RoHS compliant

Recommended applications

- Piezoelectric buzzer, Booster circuit for EL backlight (Watch, Electric thermometer, Portable device)

Standard packing quantity (Minimum quantity/Packing unit)

- 1,000 pcs or 5,000 pcs / reel

Explanation of part numbers

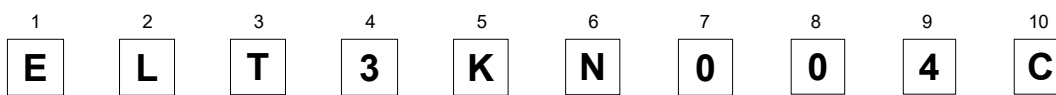

Product code

Outer size

Construction

Design No.

Packaging

Code	Packaging
B	ø 180 Reel
C	ø370 Reel

Dimensions in mm (not to scale)

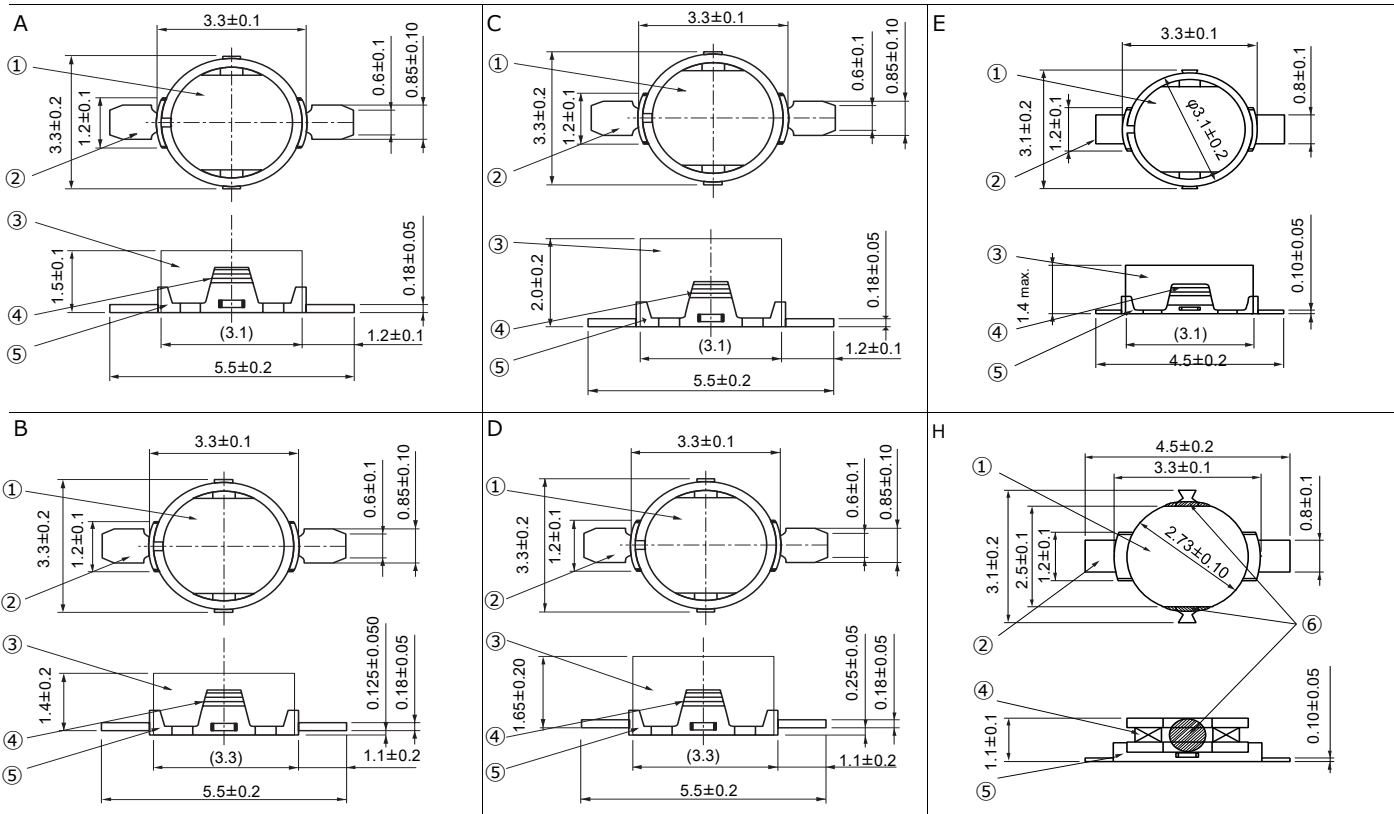

Part Name: ①Core ②Terminal ③Ring ④Coil ⑤Terminal board ⑥Adhesive

Voltage Step-up Coils (Chip type)

Standard parts

Part No.	Inductance		DC resistance		DC current (mA) max.	Dimensions	Magnetic composition			
	(mH)	Tolerance(%)	(Ω)	Tolerance(%)						
ELT3KN004	14.00	±40	125	±10	1.7	A	Permalloy ring			
ELT3KN007	20.00		170		1.4					
ELT3KN113	1.00	±10	34	±15	25.0		Brass ring			
ELT3KN126	1.50		49		29.0					
ELT3KN142	0.82		24		30.0					
ELT3KN019	14.00	±40	125	±10	1.7	B	Permalloy ring			
ELT3KN109	3.80	±10	115	±20	15.0		Brass ring			
ELT3KN114	2.50		83	±15	15.0					
ELT3KN014	30.00	±40	150	±10	1.9	C	Permalloy ring			
ELT3KN018	35.00		235		1.9					
ELT3KN028	50.00	±35	250	±15	1.4					
ELT3KN032	25.00	±40	185	±15	10.0					
ELT3KN101	10.00	±10	285	±15	1.4	Brass ring				
ELT3KN104	1.00		35		30.0					
ELT3KN118	2.50		64		20.0					
ELT3KN121	1.00		22.5		40.0					
ELT3KN122	2.00		44		20.0					
ELT3KN123	1.00		25		30.0					
ELT3KN124	4.00		85		15.0					
ELT3KN127	0.47		14		50.0					
ELT3KN128	0.56		15		45.0					
ELT3KN129	0.68		17		34.0					
ELT3KN130	2.30		51		23.0					
ELT3KN131	2.00		44		20.0					
ELT3KN020	30.00		±30		150		±10	2.5	D	Permalloy ring
ELT3KN111	7.50		±10		177		±10	10.0		Brass ring
ELT3KN125	4.00	85		±10	15.0					
ELT3KN041	14.00	±40	125	±10	1.7	Permalloy ring				
ELT3KN042	20.00		175		1.4					
ELT3KN043	12.00		117		1.7					
ELT3KN139	0.68	±10	19	±15	40.0	E	Brass ring			
ELT3KN140	0.82		22		30.0					
ELT3KN135	1.10		32		30.0					
ELT3KN136	2.00		55		20.0					
ELT3KN137	4.00		117		±10			15.0		
ELT3KN149	0.33		11		±15			60.0		
ELT3KN151	0.56		17		±15			50.0		
ELT3KN152	0.47		14		±15			50.0		
ELT3KN155	1.10		38		±10			25.0	H	Ring less
ELT3KN162	4.00		117		±10			15.0	E	Brass ring
ELT3KN163	1.10	32	±15	30.0						

"□" shows the packaging specifications.

Applied diagram examples

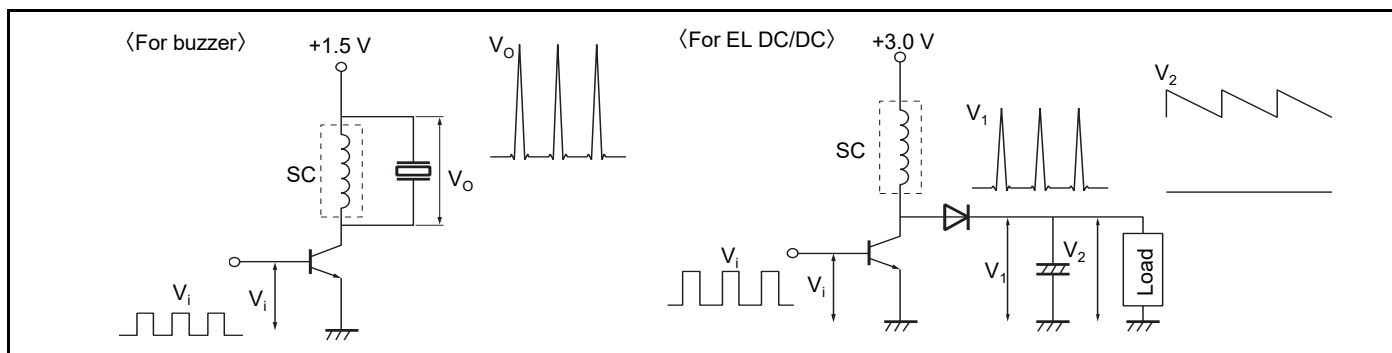

Voltage Step-up Coils (Chip type)

Reflow soldering conditions

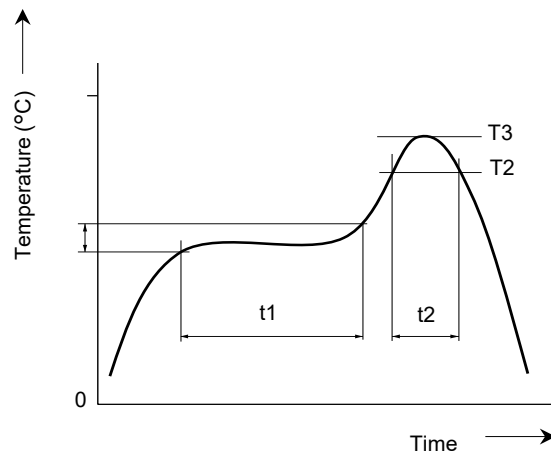

● Pb free solder recommended temperature profile

Voltage Step-up Coils

Part No.	Preheat		Soldering		Peak temperature		Time of reflow
	T1 [°C]	t1 [s]	T2 [°C]	t2 [s]	T3	T3 Limit	
ELT3KN	150 to 170	60 to 120	230 °C	30 max.	245 °C, 10 s	260 °C, 10 s	2 times max.

Voltage Step-up Coils (Chip type)

Packaging methods (Taping)

- Embossed carrier tape dimensions in mm (not to scale)

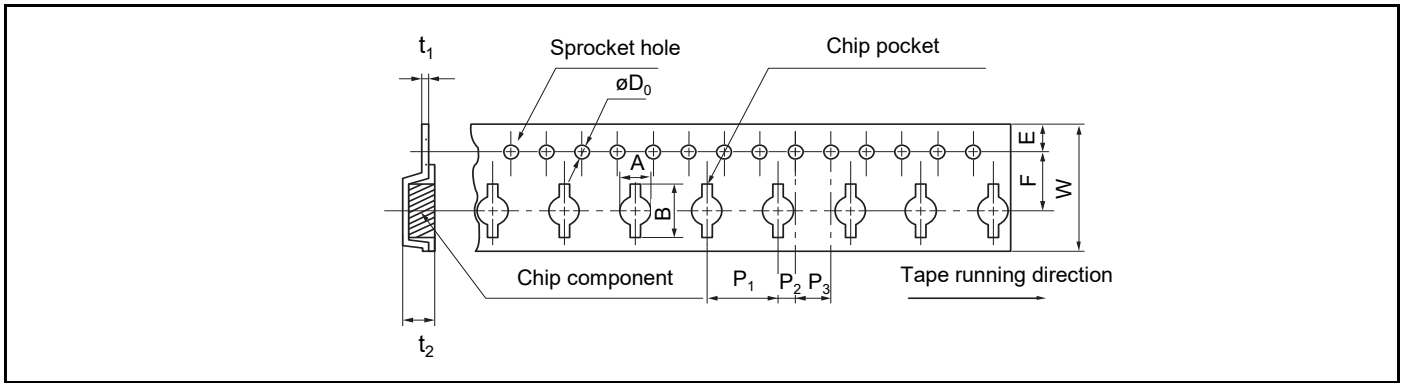

Unit : mm

Part No.	A	B	W	E	F	P ₁	P ₂	P ₀	øD ₀	t ₁	t ₂
ELT3KN	3.7	6.4	12.0	1.75	5.5	8.0	2.0	4.0	1.5	0.3	2.6

- Reel dimensions in mm (not to scale)

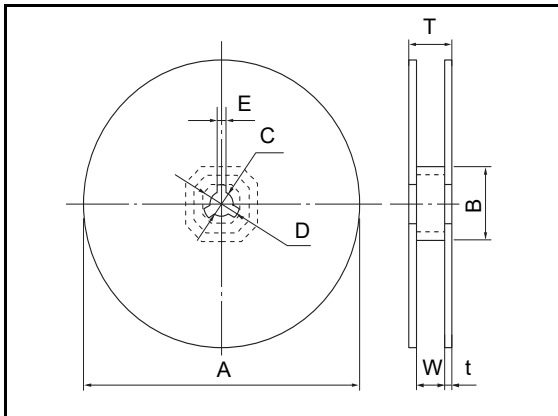

Unit : mm

Packaging	A	B	C	D	E	W	t	T
B	180	60	13	21	2	13	1.1	15.2
C	370	60	13	21	2	14	2.0	18.0

- Leader Part, Vacant Position

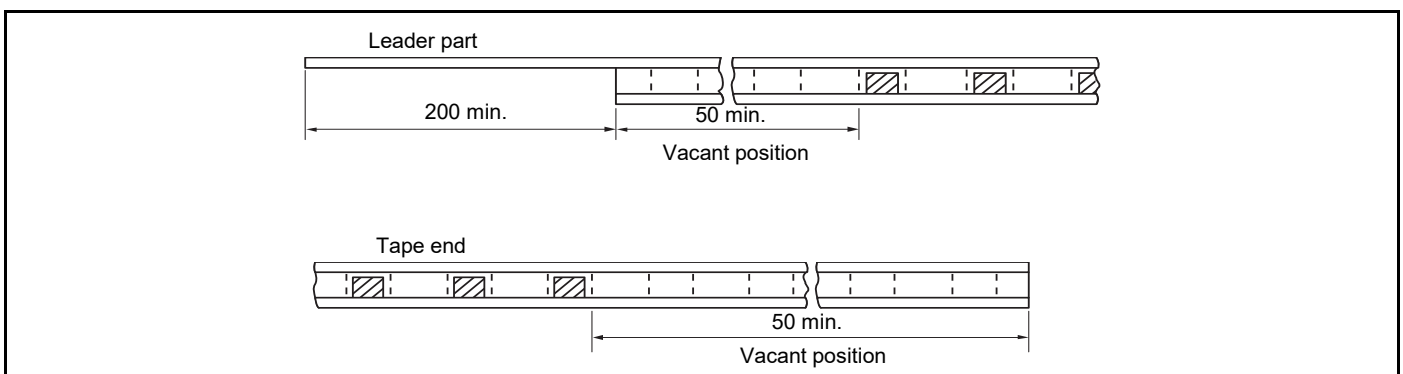

Standard packing quantity

Packaging	Quantity per reel	Kind of taping
B	1,000 pcs	B 1,000 pcs. Embossed carrier
C	5,000 pcs	Embossed carrier taping

Safety and Legal Matters to Be Observed

Product specifications and applications

- Please be advised that this product and product specifications are subject to change without notice for improvement purposes. Therefore, please request and confirm the latest delivery specifications that explain the specifications in detail before the final design, or purchase or use of the product, regardless of the application. In addition, do not use this product in any way that deviates from the contents of the company's delivery specifications.
- Unless otherwise specified in this catalog or the product specifications, this product is intended for use in general electronic equipment (AV products, home appliances, commercial equipment, office equipment, information and communication equipment, etc.).
When this product is used for the following special cases, the specification document suited to each application shall be signed/sealed (with Panasonic Industry and the user) in advance..These include applications requiring special quality and reliability, wherein their failures or malfunctions may directly threaten human life or cause harm to the human body (e.g.: space/aircraft equipment, transportation/traffic equipment, combustion equipment, medical equipment, disaster prevention/crime prevention equipment, safety equipment, etc.).

Safety design and product evaluation

- Please ensure safety through protection circuits, redundant circuits, etc., in the customer's system design so that a defect in our company's product will not endanger human life or cause other serious damage.
- This catalog shows the quality and performance of individual parts. The durability of parts varies depending on the usage environment and conditions. Therefore, please ensure to evaluate and confirm the state of each part after it has been mounted in your product in the actual operating environment before use.
If you have any doubts about the safety of this product, then please notify us immediately, and be sure to conduct a technical review including the above protection circuits and redundant circuits at your company.

Laws / Regulations / Intellectual property

- The transportation of dangerous goods as designated by UN numbers, UN classifications, etc., does not apply to this product. In addition, when exporting products, product specifications, and technical information described in this catalog, please comply with the laws and regulations of the countries to which the products are exported, especially those concerning security export control.
- Each model of this product complies with the RoHS Directive (Restriction of the use of hazardous substances in electrical and electronic equipment) (2011/65/EU and (EU) 2015/863). The date of compliance with the RoHS Directive and REACH Regulation varies depending on the product model.
Further, if you are using product models in stock and are not sure whether or not they comply with the RoHS Directive or REACH Regulation, please contact us by selecting "Sales Inquiry" from the inquiry form.
- During the manufacturing process of this product and any of its components and materials to be used, Panasonic Industry does not intentionally use ozone-depleting substances stipulated in the Montreal Protocol and specific bromine-based flame retardants such as PBBs (Poly-Brominated Biphenyls) / PBDEs (Poly-Brominated Diphenyl Ethers). In addition, the materials used in this product are all listed as existing chemical substances based on the Act on the Regulation of Manufacture and Evaluation of Chemical Substances.
- With regard to the disposal of this product, please confirm the disposal method in each country and region where it is incorporated into your company's product and used.
- The technical information contained in this catalog is intended to show only typical operation and application circuit examples of this product. This catalog does not guarantee that such information does not infringe upon the intellectual property rights of Panasonic Industry or any third party, nor imply that the license of such rights has been granted.
- Design, materials, or process related to technical owned by Panasonic Industry are subject to change without notice.

Panasonic Industry will assume no liability whatsoever if the use of our company's products deviates from the contents of this catalog or does not comply with the precautions. Please be advised of these restrictions.

⚠ Application Guidelines

1. Safety precautions

- Make sure to exchange product specifications before using this product, regardless of the intended use. The design and specifications in this catalog are subject to change without prior notice.
- Do not use the products beyond the specifications described in this catalog.
- This catalog explains the quality and performance of the products as individual components. Before use, check and evaluate their operations when installed in your products.
- If a malfunction of this product may result in the loss of human life or other serious damage in transportation equipment (trains, automobiles, ships, etc.), signaling equipment, medical equipment, aerospace equipment, electric heating equipment, combustion and gas equipment, rotating equipment, disaster prevention and security equipment, and other equipment, ensure safety by implementing a fail-safe design with the following system.
 - * Systems equipped with a protection circuit and a protection device.
 - * Systems equipped with a redundant circuit or other system to prevent an unsafe status in the event of a single fault.

2. Precautions for use

2-1. Operation range and environments

- ① These products are designed and manufactured for general and standard use in general electronic equipment (e.g. AV equipment, home electric appliances, office equipment, information and communication equipment)
- ② These products are not designed for the use in the following special conditions. Before using the products, carefully check the effects on their quality and performance, and determine whether or not they can be used.
 - In liquid, such as water, oil, chemicals, or organic solvent
 - In direct sunlight, outdoors, or in dust
 - In salty air or air with a high concentration of corrosive gas, such as Cl_2 , H_2S , NH_3 , SO_2 , or NOx
 - In an environment where these products cause dew condensation

2-2. Handling

- ① Do not bring magnets or magnetized materials close to the product. The influence of their magnetic field can change the inductance value.
- ② Do not apply strong mechanical shocks by either dropping or collision with other parts. Excessive shock can damage the part.

2-3. Resoldering with a soldering iron

- ① Resoldering should be done within 3 seconds by soldering iron, the temperature with 350 °C or less and should be cooling down after ward. Both side of terminals shall be fixed closely to PWB. And terminals shall not be pressed in heating.

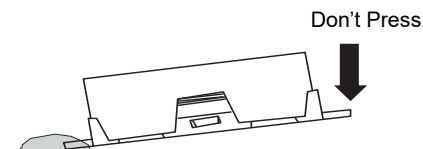

- ② The wiring tab shall not be held by sharp-edged tool.

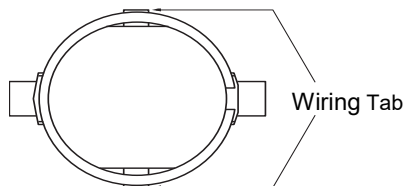

- ③ Iron shall not be put to the component itself.

2-4. Mounting side

- ① External force must be less than 4.9N while mounting.
- ② The wiring tab is expose the terminal, so please be careful when you design PWB pattern of coil circumference.

2-5. Cleaning

If ultrasonic cleaning is used, check the product with your equipment.

2-6. Storage conditions

Normal temperature (-5 to 35 °C), normal humidity (85 %RH max.), shall not be exposed to direct sunlight and harmful gases and care should be taken so as not to cause dew.

<Package markings>

Package markings include the product number, quantity, and country of origin.

In principle, the country of origin should be indicated in English.

OUR CERTIFICATE

DiGi provide top-quality products and perfect service for customer worldwide through standardization, technological innovation and continuous improvement. DiGi through third-party certification, we stricly control the quality of products and services. Welcome your RFQ to

Email: Info@DiGi-Electronics.com



Tel: +00 852-30501935

RFQ Email: Info@DiGi-Electronics.com

DiGi is a global authorized distributor of electronic components.