

PE-53681NLT Datasheet



DiGi Electronics Part Number	PE-53681NLT-DG
Manufacturer	Pulse Electronics
Manufacturer Product Number	PE-53681NLT
Description	FIXED IND 2.5UH 11.4A 5.4MOHM SM
Detailed Description	2.5 μ H Unshielded Toroidal Inductor 11.4 A 5.4mOhm Max Nonstandard

<https://www.DiGi-Electronics.com>



Tel: +00 852-30501935

RFQ Email: Info@DiGi-Electronics.com

DiGi is a global authorized distributor of electronic components.

Purchase and inquiry

Manufacturer Product Number:

PE-53681NLT

Series:

SLIC

Type:

Toroidal

Inductance:

2.5 μ H

Current Rating (Amps):

11.4 A

Shielding:

Unshielded

Q @ Freq:

-

Ratings:

-

Features:

-

Package / Case:

Nonstandard

Size / Dimension:

0.670" L x 0.670" W (17.02mm x 17.02mm)

Manufacturer:

Pulse Electronics

Product Status:

Active

Material - Core:

-

Tolerance:

-

Current - Saturation (Isat):

-

DC Resistance (DCR):

5.4mOhm Max

Frequency - Self Resonant:

-

Operating Temperature:

-40°C ~ 130°C

Mounting Type:

Surface Mount

Supplier Device Package:

-

Height - Seated (Max):

0.390" (9.91mm)

Environmental & Export classification

RoHS Status:

ROHS3 Compliant

REACH Status:

REACH Unaffected

HTSUS:

8504.50.4000

Moisture Sensitivity Level (MSL):

1 (Unlimited)

ECCN:

EAR99

SMT POWER INDUCTORS

Toroid - SLIC Series



Fifteen package sizes



Current Rating: up to 23.8ADC



Frequency Range: up to 1MHz



Pulse

A TECHNITROL COMPANY

Electrical Specifications @ 25°C — Operating Temperature -40°C to +130°C⁶

Pulse ^{4,5} Part Number	Inductance @ Irated (µH)	Irated (A)	DCR (mΩ)		Inductance @ 0Adc (µH)	Reference ET (Volt-µsec)	Flux Density Factor (K1)	Core Loss Factor (K2)	Temp. Rise Factor (K3)
			TYP	MAX					
LCI-20									
PE-53630NL	1.01	3.40	9.35	11	1.1	0.53	5.43	3.29E-11	323.9
PE-53600NL	6.2	1.40	59.5	70	7	1.33	2.17	3.29E-11	323.9
PE-53601NL	17.6	1.00	106.25	125	22.7	2.4	1.21	3.29E-11	323.9
LCI-30									
PE-53650NL	3.8	4.80	14.705	17.3	5.2	1.76	1.28	1.39E-10	148.0
PE-53631NL	9.4	2.80	36.89	43.4	12.3	2.7	0.83	1.39E-10	148.0
PE-53602NL	29.7	1.40	141.1	166	35.3	4.6	0.49	1.39E-10	148.0
PE-53606NL	114	0.94	365	405	167	10	0.23	1.39E-10	148.0
LCI-37									
PE-53661NL	2.5	8.00	7.055	8.3	3.8	1.77	1.30	1.87E-10	114.2
PE-53651NL	5.1	5.40	15.045	17.7	7.5	2.51	0.92	1.87E-10	114.2
PE-53632NL	16.2	2.70	63	72	21.9	4.29	0.54	1.87E-10	114.2
PE-53604NL	58.1	1.30	246.5	290	73	7.83	0.29	1.87E-10	114.2
PE-53608NL	192	0.90	476	560	292	15.7	0.15	1.87E-10	114.2
PE-53611NL	383	0.72	732.7	862	672	23.5	0.10	1.87E-10	114.2
LCCI-37									
PE-53717NL	43.6	1.1	247.2	309	77	7.83	0.295	1.87E-10	114.23
LCI-44									
PE-53662NL	4.9	7.80	10.54	12.4	7.9	3.04	0.67	3.35E-10	85.7
PE-53652NL	9	5.50	25	28	14	4.06	0.51	3.35E-10	85.7
PE-53633NL	29.1	2.70	85	100	40.5	6.9	0.30	3.35E-10	85.7
PE-53613NL	645	0.74	1062.5	1250	1134	36.5	0.06	3.35E-10	85.7
HCI-37									
PE-53690NL	0.81	14.30	2.125	2.5	1.25	1.035	2.23	1.87E-10	114.2
PE-53680NL	1.32	11.50	3.4	4.0	2.1	1.33	1.74	1.87E-10	114.2
LCCI-44									
PE-53718NL	21.9	2.7	72.4	90.5	39.5	6.9	0.297	3.35E-10	85.71
HCI-44									
PE-53691*NL	1.68	13.90	3.06	3.6	2.8	1.83	1.12	3.35E-10	85.7
PE-53681NL	2.5	11.40	4.59	5.4	4.2	2.23	0.92	3.35E-10	85.7
LCI-50									
PE-53663NL	9.3	7.20	15.895	18.7	16	4.92	0.41	4.52E-10	67.9
PE-53653NL	16.1	5.10	27.2	32.0	25.9	6.27	0.32	4.52E-10	67.9
PE-53634NL	50	2.60	113.05	133	72.9	10.5	0.19	4.52E-10	67.9
PE-53614NL	1070	0.71	1445	1700	1950	54.4	0.04	4.52E-10	67.9
LCCI-50									
PE-53719NL	4.025	6.4	18.4	23	6.575	3.135	0.638	4.52E-10	67.89
HCI-50									
PE-53692*NL	3.5	12.40	5.61	6.6	6.5	3.1	0.64	4.52E-10	67.9
PE-53682NL	4.7	10.40	7.055	8.3	8.4	3.58	0.56	4.52E-10	67.9
HCCI-44									
PE-53361NL	0.53	23.8	1.0	3	0.88	1	2.020	3.35E-10	85.71
HCCI-50									
PE-53362NL	1.1	21	1.7	2.5	2.1	1.75	1.116	4.52E-10	67.89
HCI-68									
PE-53700*NL	5.2	15.40	5.27	6.2	10.5	5.21	0.35	9.58E-10	44.6
PE-53683NL	9.4	10.90	10.455	12.3	17.6	6.84	0.27	9.58E-10	44.6
HCCI-68									
PE-53363NL	2.1	22.4	2.5	3.4	4	3.25	0.559	9.58E-10	44.56

NOTES:

- Reference values are for an inductor with a 55°C temperature rise. The core loss is 10% of the copper loss at the ET listed and 500kHz.
- Core does not saturate abruptly. The ET and DC current are limited by the desired inductance and temperature rise.
- In high volt-time applications, additional heating in the component can occur due to core losses in the inductor which may necessitate derating the current in order to limit the temperature rise of the component. In order to determine the approximate total losses (or temperature rise) for a given application, both copper and core losses should be taken into account.

Estimated Temperature Rise:

$$Trise = K3 * (Coreloss(W) + Copperloss(W))^{0.33} (C)$$

$$CopperLoss = Irms^2 * DCR_Typical (m\Omega) / 1000$$

$$CoreLoss = K2 * (Freq_kHz)^{1.26} * (\Delta B)^{2.11}$$

$$\Delta B = K1 * Volt\text{-}\mu\text{sec} * 100$$

- Optional Tape & Reel packaging can be ordered by adding a "T" suffix to the part number (i.e. PE-53600NL becomes PE-53600NLT). Pulse complies to industry standard tape and reel specification EIA481.
- The "NL" suffix indicates an RoHS-compliant part number. Non-NL suffixed parts are not necessarily RoHS compliant, but are electrically and mechanically equivalent to NL versions. If a part number does not have the "NL" suffix, but an RoHS compliant version is required, please contact Pulse for availability.
- The temperature of the component (ambient plus temperature rise) must be within the stated operating temperature range.

SMT POWER INDUCTORS

Toroid - SLIC Series



Mechanicals

High Current Inductors (HCI)

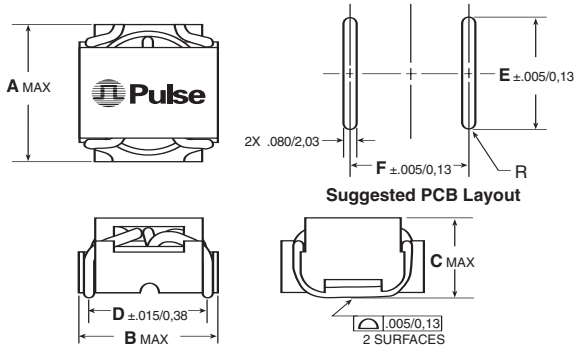

Low Current Inductors (LCI)

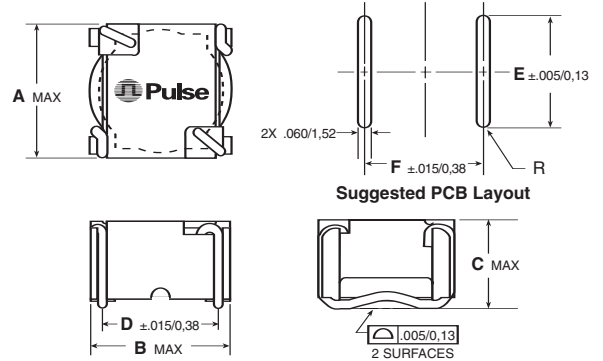

* Dimension "C" is .400/10,16 for the marked models because of heavier wire gage.

PKG	A	B	C	D	E	F
HCI-37	.620	.605	.370	.500	.440	.500
	15,75	15,37	9,40	12,70	11,18	12,70
HCI-44	.670	.670	.390*	.560	.490	.570
	17,02	17,02	9,91	14,22	12,45	14,48
HCI-50	.740	.740	.390*	.630	.560	.640
	18,80	18,80	9,91	16,00	14,22	16,26
HCI-68	.940	.940	.390*	.820	.700	.830
	23,88	23,88	9,91	20,83	17,78	21,08

Dimensions: $\frac{\text{Inches}}{\text{mm}}$

PKG	A	B	C	D	E	F
LCI-20	.340	.340	.270	.260	.300	.270
	8,64	8,64	6,86	6,60	7,62	6,86
LCI-30	.435	.440	.360	.350	.400	.360
	11,05	11,18	9,14	8,89	10,16	9,14
LCI-37	.565	.570	.360	.450	.520	.460
	14,35	14,48	9,14	11,43	13,21	11,68
LCI-44	.600	.620	.390	.500	.550	.500
	15,24	15,75	9,91	12,70	13,97	12,70
LCI-50	.670	.700	.390	.580	.620	.590
	17,02	17,78	9,91	14,73	15,75	14,99

High Current Coupled Inductors (HCCI)

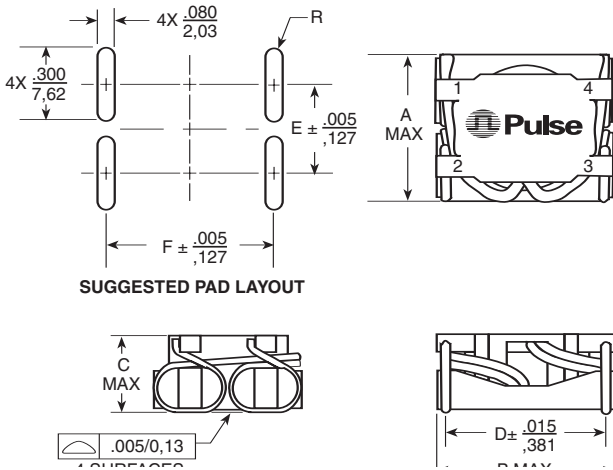

Low Current Coupled Inductors (LCCI)

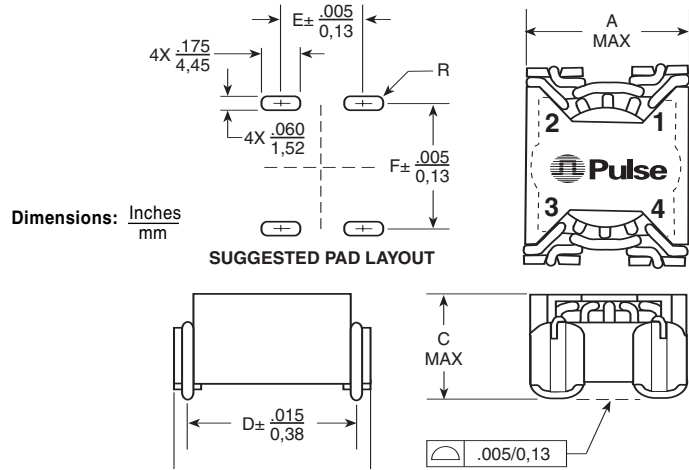

Schematic

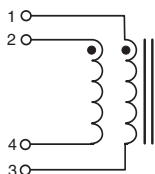

Size Codes

	HCCI-44	HCCI-50	HCCI-68	LCCI-37	LCCI-44	LCCI-50
A	.715/18,16	.800/20,32	1.000/25,40	.560/14,22	.590/14,99	.670/17,02
B	.865/21,97	.910/23,11	1.110/28,19	.645/16,38	.715/18,16	.770/19,56
C	.390/9,91	.390/9,91	.390/9,91	.350/8,89	.390/9,91	.390/9,91
D	.760/10,30	.800/20,32	1.000/25,40	.520/13,21	.600/15,24	.650/16,51
E	.360/9,14	.440/11,18	.620/15,75	.340/8,64	.370/9,40	.445/11,30
F	.770/19,56	.810/20,57	1.010/25,65	.530/13,46	.610/15,49	.660/16,76

Schematic

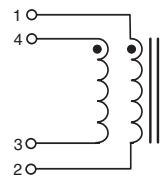

Dimensions: $\frac{\text{Inches}}{\text{mm}}$

OUR CERTIFICATE

DiGi provide top-quality products and perfect service for customer worldwide through standardization, technological innovation and continuous improvement. DiGi through third-party certification, we stricly control the quality of products and services. Welcome your RFQ to

Email: Info@DiGi-Electronics.com



Tel: +00 852-30501935

RFQ Email: Info@DiGi-Electronics.com

DiGi is a global authorized distributor of electronic components.