

932SQL456AKLF Datasheet

www.digi-electronics.com

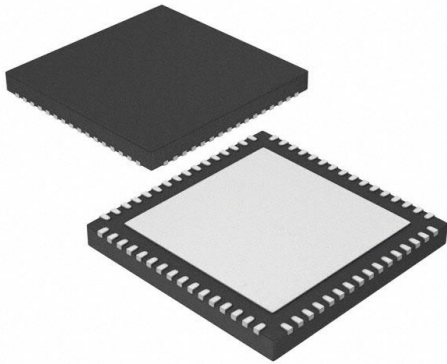

<https://www.DiGi-Electronics.com>

DiGi Electronics Part Number	932SQL456AKLF-DG
Manufacturer	Renesas Electronics Corporation
Manufacturer Product Number	932SQL456AKLF
Description	VFQFPN 9.00X9.00X0.90 MM, 0.50MM
Detailed Description	PCI Express (PCIe) IC 100MHz 1 Output 64-VFQFPN (9x9)



Tel: +00 852-30501935

RFQ Email: Info@DiGi-Electronics.com

DiGi is a global authorized distributor of electronic components.

Purchase and inquiry

Manufacturer Product Number:

932SQL456AKLF

Series:

-

DiGi-Electronics Programmable:

Not Verified

Main Purpose:

PCI Express (PCIe)

Output:

LP-HCSL

Ratio - Input:Output:

1:11

Frequency - Max:

100MHz

Operating Temperature:

0°C ~ 70°C (TA)

Package / Case:

64-VFQFN Exposed Pad

Base Product Number:

932SQL456

Manufacturer:

Renesas Electronics Corporation

Product Status:

Obsolete

PLL:

Yes

Input:

Crystal

Number of Circuits:

1

Differential - Input:Output:

No/Yes

Voltage - Supply:

3.135V ~ 3.465V

Mounting Type:

Surface Mount

Supplier Device Package:

64-VFQFPN (9x9)

Environmental & Export classification

RoHS Status:

ROHS3 Compliant

REACH Status:

REACH Unaffected

Moisture Sensitivity Level (MSL):

3 (168 Hours)

ECCN:

OBSOLETE



Low-Power CK420BQ Derivative for PCIe Separate Clock Architectures

932SQL456

DATASHEET

General Description

The 932SQL456 is a low power version of the CK420BQ synthesizer for Intel-based server platforms. It has 85 ohm Low-Power (LP) HCSL outputs that save 48 resistors and reduce power consumption by 50% compared to the standard CK420BQ. The 932SQL456 is driven with a 25MHz crystal for maximum performance. It generates CPU outputs of 100MHz. This device meets Separate- Reference-no-Spread (SRnS) PCIe requirements making it ideal for use in systems that need to communicate “outside the box”.

Recommended Application

Low-Power CK420BQ for SRnS PCIe Applications

Key Specifications

- CPU, SRC, NS_SRC and NS_SAS cycle-cycle jitter <50ps
- Output to output skew <50ps
- Phase jitter: PCIe Gen2 SRnS <2.2ps rms
- Phase jitter: PCIe Gen3 SRnS <0.7ps rms
- Phase jitter: QPI <0.3ps rms
- Phase jitter: NS-SAS <1.3ps rms using long period phase jitter method

Pin Configurations

SMBCLK	1	64	SMBDAT
GND14	2	63	VDDCPU
AVDD14	3	62	CPU3_Z85T
VDD14	4	61	CPU3_Z85C
vREF14_2x/TEST_SELLY	5	60	CPU2_Z85T
GND14	6	59	CPU2_Z85C
GNDXTAL	7	58	GNDCPU
X1_25	8	57	VDDCPU
X2_25	9	56	CPU1_Z85T
VDDXTAL	10	55	CPU1_Z85C
GNDPCI	11	54	CPU0_Z85T
VDDPCI	12	53	CPU0_Z85C
PCI4_2x	13	52	GNDNS
PCI3_2x	14	51	AVDD_NS_SAS
PCI2_2x	15	50	NS_SAS1_Z85T
PCI1_2x	16	49	NS_SAS1_Z85C
PCI0_2x	17	48	NS_SAS0_Z85T
GNDPCI	18	47	NS_SAS0_Z85C
VDDPCI	19	46	GNDNS
VDD48	20	45	VDDNS
48M_2x	21	44	NS_SRC1_Z85T
GND48	22	43	NS_SRC1_Z85C
GND96	23	42	NS_SRC0_Z85T
DOT96_Z85T	24	41	NS_SRC0_Z85C
DOT96_Z85C	25	40	NC
AVDD96	26	39	GNDSRC
TEST_MODE	27	38	AVDD_SRC
CKPWRGD#/PD	28	37	VDDSRC
VDDSRC	29	36	SRC2_Z85T
SRC0_Z85T	30	35	SRC2_Z85C
SRC0_Z85C	31	34	SRC1_Z85T
GNDSRC	32	33	SRC1_Z85C

64-TSSOP

Note: Pins with ^ prefix have internal 120K pullup
Pins with v prefix have internal 120K pulldown

Features/Benefits

- Integrated 85-ohm differential terminations; saves 48 resistors compared to CK420BQ
- LP-HCSL outputs; up to 50% power savings compared to standard CK420BQ
- 64-pin TSSOP and VFQFPN packages; smallest board footprint
- Available in -40° to +85°C industrial temperature range version; supports demanding operating environments

Output Features

- Differential outputs are LP-HCSL with integrated 85Ω terminations
- 11 – *non-spreading* interchangeable 100MHz differential outputs
 - 4 – “CPU” outputs
 - 2 – “NS_SAS” outputs
 - 2 – “NS_SRC” outputs
 - 3 – “SRC” outputs
- 1 – DOT96 96MHz output
- 1 – 3.3V 48M output
- 5 – 3.3V PCI outputs
- 1 – 3.3V 14.318M output

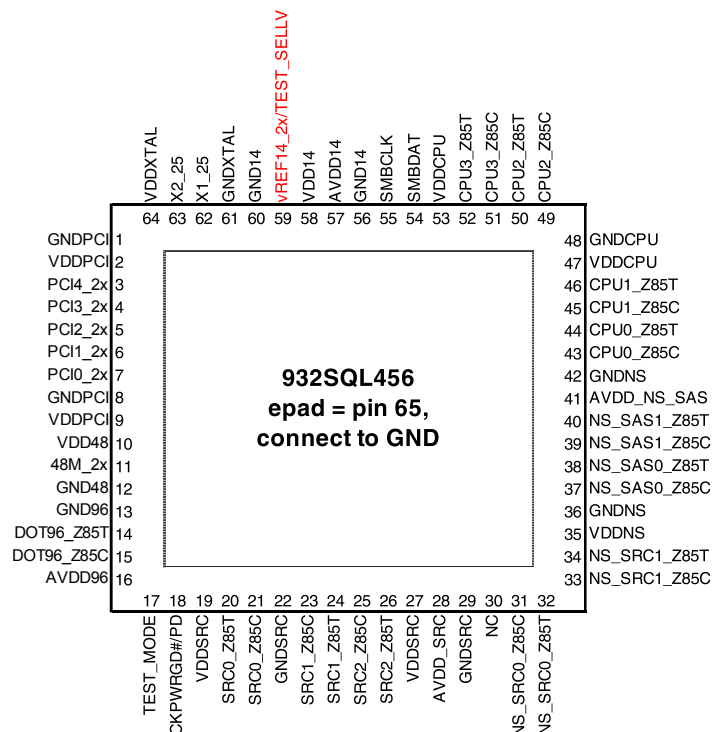

64-Pin VFQFPN

Note: Pins with ^ prefix have internal 120K pullup
Pins with v prefix have internal 120K pulldown

64TSSOP Pin Descriptions

PIN #	PIN NAME	TYPE	DESCRIPTION
1	SMBCLK	IN	Clock pin of SMBUS circuitry, 5V tolerant
2	GND14	PWR	Ground pin for 14MHz output and logic.
3	AVDD14	PWR	Analog power pin for 14MHz PLL
4	VDD14	PWR	Power pin for 14MHz output and logic
5	vREF14_2x/TEST_SELLV	I/O	14.318 MHz reference clock capable of driving 2 loads/ TEST_SEL latched input to enable test mode. The TEST_SEL input is a low threshold input. See the Electrical Tables and the Test Clarification Table. This pin has a weak (~120Kohm) internal pull down.
6	GND14	PWR	Ground pin for 14MHz output and logic.
7	GNDXTAL	PWR	Ground pin for Crystal Oscillator.
8	X1_25	IN	Crystal input, Nominally 25.00MHz.
9	X2_25	OUT	Crystal output, Nominally 25.00MHz.
10	VDDXTAL	PWR	3.3V power for the crystal oscillator.
11	GNDPCI	PWR	Ground pin for PCI outputs and logic.
12	VDDPCI	PWR	3.3V power for the PCI outputs and logic
13	PCI4_2x	OUT	3.3V PCI clock output
14	PCI3_2x	OUT	3.3V PCI clock output
15	PCI2_2x	OUT	3.3V PCI clock output
16	PCI1_2x	OUT	3.3V PCI clock output
17	PCI0_2x	OUT	3.3V PCI clock output
18	GNDPCI	PWR	Ground pin for PCI outputs and logic.
19	VDDPCI	PWR	3.3V power for the PCI outputs and logic
20	VDD48	PWR	3.3V power for the 48MHz output and logic
21	48M_2x	OUT	3.3V 48MHz output
22	GND48	PWR	Ground pin for 48MHz output and logic.
23	GND96	PWR	Ground pin for DOT96 output and logic.
24	DOT96_Z85T	OUT	True clock of low-power push-pull differential 96MHz output. Internally terminated to drive 85ohm transmission lines with no external components.
25	DOT96_Z85C	OUT	Complementary clock of low-power push-pull differential 96MHz output. Internally terminated to drive 85ohm transmission lines with no external components.
26	AVDD96	PWR	3.3V power for the 48/96MHz PLL and the 96MHz output and logic
27	TEST_MODE	IN	TEST_MODE is a real time input to select between Hi-Z and REF/N divider mode while in test mode. Refer to Test Clarification Table.
28	CKPWRGD#/PD	IN	CKPWRGD# is an active low input used to sample latched inputs and allow the device to Power Up. PD is an asynchronous active high input pin used to put the device into a low power state. The internal clocks and PLLs are stopped.
29	VDDSRC	PWR	3.3V power for the SRC outputs and logic
30	SRC0_Z85T	OUT	True clock of low-power push-pull differential SRC output. Internally terminated to drive 85ohm transmission lines with no external components.
31	SRC0_Z85C	OUT	Complementary clock of low-power push-pull differential SRC output. Internally terminated to drive 85ohm transmission lines with no external components.
32	GNDSRC	PWR	Ground pin for SRC outputs and logic.
33	SRC1_Z85C	OUT	Complementary clock of low-power push-pull differential SRC output. Internally terminated to drive 85ohm transmission lines with no external components.
34	SRC1_Z85T	OUT	True clock of low-power push-pull differential SRC output. Internally terminated to drive 85ohm transmission lines with no external components.
35	SRC2_Z85C	OUT	Complementary clock of low-power push-pull differential SRC output. Internally terminated to drive 85ohm transmission lines with no external components.
36	SRC2_Z85T	OUT	True clock of low-power push-pull differential SRC output. Internally terminated to drive 85ohm transmission lines with no external components.
37	VDDSRC	PWR	3.3V power for the SRC outputs and logic
38	AVDD_SRC	PWR	3.3V power for the SRC PLL analog circuits
39	GNDSRC	PWR	Ground pin for SRC outputs and logic.
40	NC	N/A	No Connection.

64TSSOP Pin Descriptions (cont.)

PIN #	PIN NAME	TYPE	DESCRIPTION
41	NS_SRC0_Z85C	OUT	Complementary clock of low-power push-pull differential non-spreading SRC output. Internally terminated to drive 85ohm transmission lines with no external components.
42	NS_SRC0_Z85T	OUT	True clock of low-power push-pull differential non-spreading SRC output. Internally terminated to drive 85ohm transmission lines with no external components.
43	NS_SRC1_Z85C	OUT	Complementary clock of low-power push-pull differential non-spreading SRC output. Internally terminated to drive 85ohm transmission lines with no external components.
44	NS_SRC1_Z85T	OUT	True clock of low-power push-pull differential non-spreading SRC output. Internally terminated to drive 85ohm transmission lines with no external components.
45	VDDNS	PWR	3.3V power for the Non-Spreading differential outputs outputs and logic
46	GNDNS	PWR	Ground pin for non-spreading differential outputs and logic.
47	NS_SAS0_Z85C	OUT	Complementary clock of low-power push-pull differential non-spreading SAS output. Internally terminated to drive 85ohm transmission lines with no external components.
48	NS_SAS0_Z85T	OUT	True clock of low-power push-pull differential non-spreading SAS output. Internally terminated to drive 85ohm transmission lines with no external components.
49	NS_SAS1_Z85C	OUT	Complementary clock of low-power push-pull differential non-spreading SAS output. Internally terminated to drive 85ohm transmission lines with no external components.
50	NS_SAS1_Z85T	OUT	True clock of low-power push-pull differential non-spreading SAS output. Internally terminated to drive 85ohm transmission lines with no external components.
51	AVDD_NS_SAS	PWR	3.3V power for the non-spreading SAS/SRC PLL analog circuits.
52	GNDNS	PWR	Ground pin for non-spreading differential outputs and logic.
53	CPU0_Z85C	OUT	Complementary clock of low-power push-pull differential CPU output. Internally terminated to drive 85ohm transmission lines with no external components.
54	CPU0_Z85T	OUT	True clock of low-power push-pull differential CPU output. Internally terminated to drive 85ohm transmission lines with no external components.
55	CPU1_Z85C	OUT	Complementary clock of low-power push-pull differential CPU output. Internally terminated to drive 85ohm transmission lines with no external components.
56	CPU1_Z85T	OUT	True clock of low-power push-pull differential CPU output. Internally terminated to drive 85ohm transmission lines with no external components.
57	VDDCPU	PWR	3.3V power for the CPU outputs and logic
58	GNDCPU	PWR	Ground pin for CPU outputs and logic.
59	CPU2_Z85C	OUT	Complementary clock of low-power push-pull differential CPU output. Internally terminated to drive 85ohm transmission lines with no external components.
60	CPU2_Z85T	OUT	True clock of low-power push-pull differential CPU output. Internally terminated to drive 85ohm transmission lines with no external components.
61	CPU3_Z85C	OUT	Complementary clock of low-power push-pull differential CPU output. Internally terminated to drive 85ohm transmission lines with no external components.
62	CPU3_Z85T	OUT	True clock of low-power push-pull differential CPU output. Internally terminated to drive 85ohm transmission lines with no external components.
63	VDDCPU	PWR	3.3V power for the CPU outputs and logic
64	SMBDAT	I/O	Data pin of SMBUS circuitry, 5V tolerant

64VFQFPN Pin Descriptions

PIN #	PIN NAME	TYPE	DESCRIPTION
1	GNDPCI	PWR	Ground pin for PCI outputs and logic.
2	VDDPCI	PWR	3.3V power for the PCI outputs and logic
3	PCI4_2x	OUT	3.3V PCI clock output
4	PCI3_2x	OUT	3.3V PCI clock output
5	PCI2_2x	OUT	3.3V PCI clock output
6	PCI1_2x	OUT	3.3V PCI clock output
7	PCI0_2x	OUT	3.3V PCI clock output
8	GNDPCI	PWR	Ground pin for PCI outputs and logic.
9	VDDPCI	PWR	3.3V power for the PCI outputs and logic
10	VDD48	PWR	3.3V power for the 48MHz output and logic
11	48M_2x	OUT	3.3V 48MHz output
12	GND48	PWR	Ground pin for 48MHz output and logic.
13	GND96	PWR	Ground pin for DOT96 output and logic.
14	DOT96_Z85T	OUT	True clock of low-power push-pull differential 96MHz output. Internally terminated to drive 85ohm transmission lines with no external components.
15	DOT96_Z85C	OUT	Complementary clock of low-power push-pull differential 96MHz output. Internally terminated to drive 85ohm transmission lines with no external components.
16	AVDD96	PWR	3.3V power for the 48/96MHz PLL and the 96MHz output and logic
17	TEST_MODE	IN	TEST_MODE is a real time input to select between Hi-Z and REF/N divider mode while in test mode. Refer to Test Clarification Table.
18	CKPWRGD#/PD	IN	CKPWRGD# is an active low input used to sample latched inputs and allow the device to Power Up. PD is an asynchronous active high input pin used to put the device into a low power state. The internal clocks and PLLs are stopped.
19	VDDSRC	PWR	3.3V power for the SRC outputs and logic
20	SRC0_Z85T	OUT	True clock of low-power push-pull differential SRC output. Internally terminated to drive 85ohm transmission lines with no external components.
21	SRC0_Z85C	OUT	Complementary clock of low-power push-pull differential SRC output. Internally terminated to drive 85ohm transmission lines with no external components.
22	GNDSRC	PWR	Ground pin for SRC outputs and logic.
23	SRC1_Z85C	OUT	Complementary clock of low-power push-pull differential SRC output. Internally terminated to drive 85ohm transmission lines with no external components.
24	SRC1_Z85T	OUT	True clock of low-power push-pull differential SRC output. Internally terminated to drive 85ohm transmission lines with no external components.
25	SRC2_Z85C	OUT	Complementary clock of low-power push-pull differential SRC output. Internally terminated to drive 85ohm transmission lines with no external components.
26	SRC2_Z85T	OUT	True clock of low-power push-pull differential SRC output. Internally terminated to drive 85ohm transmission lines with no external components.
27	VDDSRC	PWR	3.3V power for the SRC outputs and logic
28	AVDD_SRC	PWR	3.3V power for the SRC PLL analog circuits
29	GNDSRC	PWR	Ground pin for SRC outputs and logic.
30	NC	N/A	No Connection.
31	NS_SRC0_Z85C	OUT	Complementary clock of low-power push-pull differential non-spreading SRC output. Internally terminated to drive 85ohm transmission lines with no external components.
32	NS_SRC0_Z85T	OUT	True clock of low-power push-pull differential non-spreading SRC output. Internally terminated to drive 85ohm transmission lines with no external components.
33	NS_SRC1_Z85C	OUT	Complementary clock of low-power push-pull differential non-spreading SRC output. Internally terminated to drive 85ohm transmission lines with no external components.
34	NS_SRC1_Z85T	OUT	True clock of low-power push-pull differential non-spreading SRC output. Internally terminated to drive 85ohm transmission lines with no external components.
35	VDDNS	PWR	3.3V power for the Non-Spreading differential outputs and logic
36	GNDNS	PWR	Ground pin for non-spreading differential outputs and logic.
37	NS_SAS0_Z85C	OUT	Complementary clock of low-power push-pull differential non-spreading SAS output. Internally terminated to drive 85ohm transmission lines with no external components.
38	NS_SAS0_Z85T	OUT	True clock of low-power push-pull differential non-spreading SAS output. Internally terminated to drive 85ohm transmission lines with no external components.

64VFQFPN Pin Descriptions (cont.)

PIN #	PIN NAME	TYPE	DESCRIPTION
39	NS_SAS1_Z85C	OUT	Complementary clock of low-power push-pull differential non-spreading SAS output. Internally terminated to drive 85ohm transmission lines with no external components.
40	NS_SAS1_Z85T	OUT	True clock of low-power push-pull differential non-spreading SAS output. Internally terminated to drive 85ohm transmission lines with no external components.
41	AVDD_NS_SAS	PWR	3.3V power for the non-spreading SAS/SRC PLL analog circuits.
42	GNDNS	PWR	Ground pin for non-spreading differential outputs and logic.
43	CPU0_Z85C	OUT	Complementary clock of low-power push-pull differential CPU output. Internally terminated to drive 85ohm transmission lines with no external components.
44	CPU0_Z85T	OUT	True clock of low-power push-pull differential CPU output. Internally terminated to drive 85ohm transmission lines with no external components.
45	CPU1_Z85C	OUT	Complementary clock of low-power push-pull differential CPU output. Internally terminated to drive 85ohm transmission lines with no external components.
46	CPU1_Z85T	OUT	True clock of low-power push-pull differential CPU output. Internally terminated to drive 85ohm transmission lines with no external components.
47	VDDCPU	PWR	3.3V power for the CPU outputs and logic
48	GNDCPU	PWR	Ground pin for CPU outputs and logic.
49	CPU2_Z85C	OUT	Complementary clock of low-power push-pull differential CPU output. Internally terminated to drive 85ohm transmission lines with no external components.
50	CPU2_Z85T	OUT	True clock of low-power push-pull differential CPU output. Internally terminated to drive 85ohm transmission lines with no external components.
51	CPU3_Z85C	OUT	Complementary clock of low-power push-pull differential CPU output. Internally terminated to drive 85ohm transmission lines with no external components.
52	CPU3_Z85T	OUT	True clock of low-power push-pull differential CPU output. Internally terminated to drive 85ohm transmission lines with no external components.
53	VDDCPU	PWR	3.3V power for the CPU outputs and logic
54	SMBDAT	I/O	Data pin of SMBUS circuitry, 5V tolerant
55	SMBCLK	IN	Clock pin of SMBUS circuitry, 5V tolerant
56	GND14	PWR	Ground pin for 14MHz output and logic.
57	AVDD14	PWR	Analog power pin for 14MHz PLL
58	VDD14	PWR	Power pin for 14MHz output and logic
59	vREF14_2x/TEST_SELLV	I/O	14.318 MHz reference clock capable of driving 2 loads/ TEST_SEL latched input to enable test mode. The TEST_SEL input is a low threshold input. See the Electrical Tables and the Test Clarification Table. This pin has a weak (~120Kohm) internal pull down.
60	GND14	PWR	Ground pin for 14MHz output and logic.
61	GNDXTAL	PWR	Ground pin for Crystal Oscillator.
62	X1_25	IN	Crystal input, Nominally 25.00MHz.
63	X2_25	OUT	Crystal output, Nominally 25.00MHz.
64	VDDXTAL	PWR	3.3V power for the crystal oscillator.
65	EPAD	GND	Epad should be connected to ground.

Block Diagram

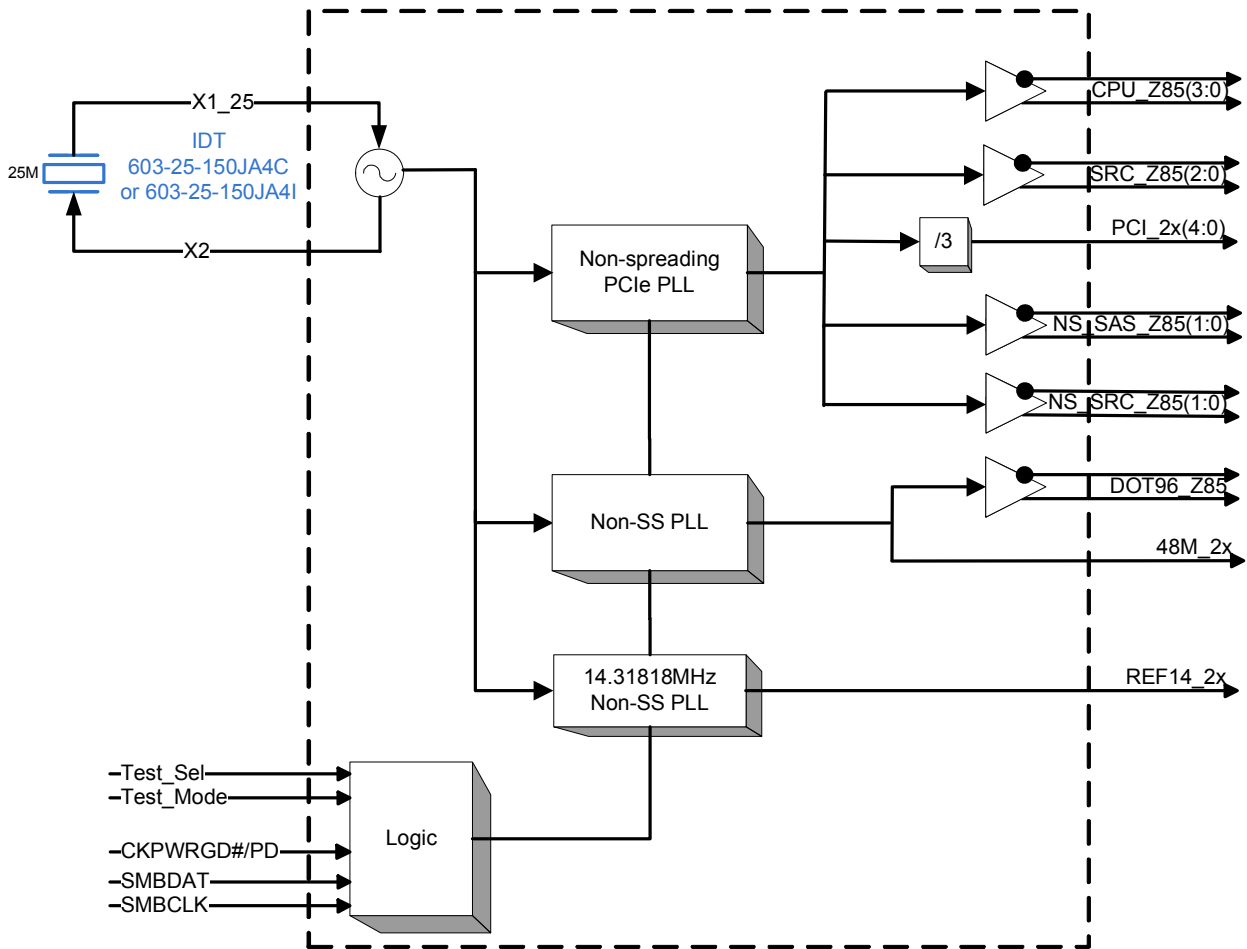

Power Supply and Test Loads

Power Group Pin Numbers

VFQFPN		TSSOP		Description
VDD	GND	VDD	GND	
57	56	3	2	14MHz PLL Analog
58	60	4	6	REF14M Output and Logic
64	61	10	7	25MHz XTAL
2, 9	1, 8	12, 19	11, 18	PCI Outputs and Logic
10	12	20	22	48MHz Output and Logic
16	13	26	23	96MHz PLL Analog, Output and Logic
19, 27	22	29, 37	32	SRC Outputs and Logic
28	29	38	39	SRC PLL Analog
35	36	45	46	Non-Spreading Differential Outputs & Logic
41	42	51	52	NS-SAS/SRC PLL Analog
47, 53	48	57,63	58	CPU Outputs and Logic

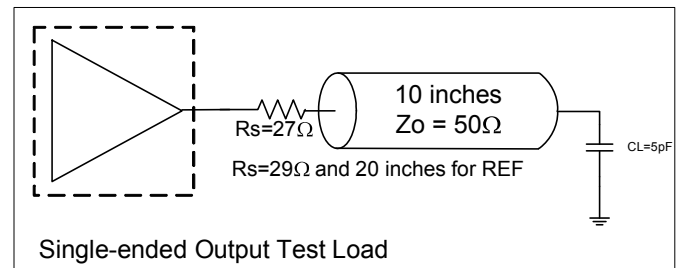
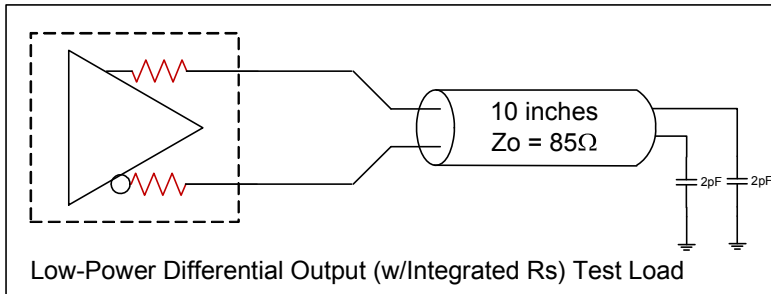

Alternate Terminations

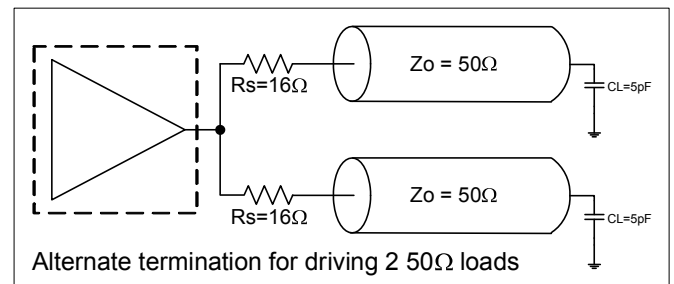
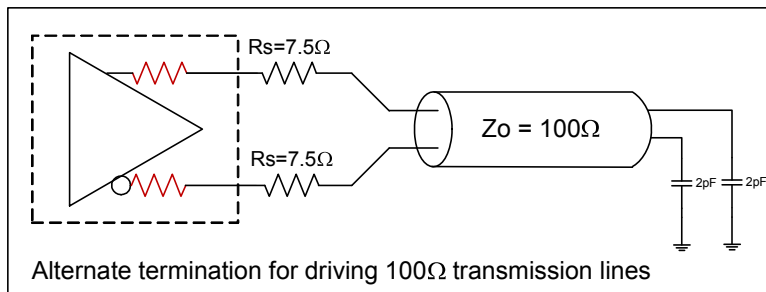

The 932SQL456 can also drive other logic levels such as LVPECL, LVDS, and CML. See [“AN-891 Driving LVPECL, LVDS, and CML Logic with IDT’s “Universal” Low-Power HCSL Outputs”](#) for details.

Functionality Tables

932SQL456 Functionality

CPU	SRC	PCI	REF	NS_SAS NS_SRC	DOT96	USB	
100	100	33.33	14.318	100.00	96.00	48.00	MHz

932SQL456 Power Down Functionality

CKPWRGD#/PD	Differential Outputs	Single-ended Outputs	Single-ended Outputs w/Latch
1	Low/Low	Low	Low ¹
0	Running		

1. Single-ended outputs with a Latch will be Hi-Z until the first application of CKPWRGD#.

Clock AC Tolerances

	CPU, SRC	NS_SAS, NS_SRC	PCI	DOT96	48MHz	REF	
PPM tolerance	100	100	100	100	100	100	ppm
Cycle to Cycle Jitter	50	50	250	50	250	250	ps
Spread	0.00%	0.00%	0.00%	0	0.00%	0.00%	%

Clock Periods–Outputs

SSC OFF	Center Freq. MHz	Measurement Window							Units	Notes
		1 Clock	1us	0.1s	0.1s	0.1s	1us	1 Clock		
		-c2c jitter AbsPer Min	-SSC Short-Term Average Min	- ppm Long-Term Average Min	0 ppm Period Nominal	+ ppm Long-Term Average Max	+SSC Short-Term Average Max	+c2c jitter AbsPer Max		
SRC, NS_SAS, NS_SRC	100.000	9.94900		9.99900	10.00000	10.00100		10.05100	ns	1,2
PCI	33.333	29.74700		29.99700	30.00000	30.00300		30.25300	ns	1,2
DOT96	96.000	10.36563		10.41563	10.41667	10.41771		10.46771	ns	1,2
48MHz	48.000	20.58125		20.83125	20.83333	20.83542		21.08542	ns	1,2
REF	14.318	69.78429		69.83429	69.84128	69.84826		69.89826	ns	1,2

¹Guaranteed by design and characterization, not 100% tested in production.

²All Long Term Accuracy specifications are guaranteed with the assumption that the REF output is tuned to exactly 14.31818MHz.

Absolute Maximum Ratings

Stresses above the ratings listed below can cause permanent damage to the 932SQL456. These ratings, which are standard values for IDT commercially rated parts, are stress ratings only. Functional operation of the device at these or any other conditions above those indicated in the operational sections of the specifications is not implied. Exposure to absolute maximum rating conditions for extended periods can affect product reliability. Electrical parameters are guaranteed only over the recommended operating temperature range.

PARAMETER	SYMBOL	CONDITIONS	MIN	TYP	MAX	UNITS	NOTES
3.3V Core Supply Voltage	VDDA				4.6	V	1,2
3.3V Logic Supply Voltage	VDD				4.6	V	1,2
Input Low Voltage	V _{IL}		GND-0.5			V	1
Input High Voltage	V _{IH}	Except for SMBus interface			V _{DD} +0.5V	V	1
Input High Voltage	V _{IHSMB}	SMBus clock and data pins			5.5V	V	1
Storage Temperature	T _s		-65		150	°C	1
Junction Temperature	T _j				125	°C	1
Case Temperature	T _c				110	°C	1
Input ESD protection	ESD prot	Human Body Model	2000			V	1

¹Guaranteed by design and characterization, not 100% tested in production.

²Operation under these conditions is neither implied nor guaranteed.

Electrical Characteristics—Current Consumption

T_A = T_{AMB}; Supply Voltage VDDx = 3.3 V +/-5%

PARAMETER	SYMBOL	CONDITIONS	MIN	TYP	MAX	UNITS	NOTES
Operating Supply Current	I _{DD3.3OP}	All outputs active @100MHz, C _L = Full load;		217	250	mA	1
Powerdown Current	I _{DD3.3PDZ}			4.3	8	mA	1

¹Guaranteed by design and characterization, not 100% tested in production.

AC Electrical Characteristics—CPU, SRC, NS_SAS, NS_SRC, DOT96 LP-HCSL Outputs

T_A = T_{AMB}; Supply Voltage VDDx = 3.3 V +/-5%

PARAMETER	SYMBOL	CONDITIONS	MIN	TYP	MAX	UNITS	NOTES
Duty Cycle	t _{DC}	Measured differentially, PLL Mode	45	49.6%	55	%	
Skew, Output to Output	t _{sk3SRC}	Across all SRC outputs, V _T = 50%		23	50	ps	1
Skew, Output to Output	t _{sk3CPU}	Across all CPU outputs, V _T = 50%		24	50	ps	1
Jitter, Cycle to cycle	t _{jcyc-cyc}	CPU, SRC, NS_SAS outputs		6	50	ps	1,3
		DOT96 output		5	50	ps	1,3

¹Guaranteed by design and characterization, not 100% tested in production.

²Z_o=85Ω (differential impedance).

³Measured from differential waveform

Electrical Characteristics–Input/Supply/Common Parameters

TA = T_{AMB}; Supply Voltage VDDx = 3.3 V +/-5%

PARAMETER	SYMBOL	CONDITIONS	MIN	TYP	MAX	UNITS	NOTES
Operating Voltage	V		3.135	3.3	3.465	V	
Ambient Operating Temperature	T _{AMB}	Commercial range	0		70	°C	
		Industrial range	-40		85	°C	
Input High Voltage	V _{IH}	Single-ended inputs, except SMBus, low threshold and tri-level inputs	2		V _{DD} + 0.3	V	
Input Low Voltage	V _{IL}	Single-ended inputs, except SMBus, low threshold and tri-level inputs	GND - 0.3		0.8	V	
Input Current	I _{IN}	Single-ended inputs, V _{IN} = GND, V _{IN} = VDD	-5		5	uA	
	I _{INP}	Single-ended inputs. V _{IN} = 0 V; Inputs with internal pull-up resistors V _{IN} = VDD; Inputs with internal pull-down resistors	-200		200	uA	
Low Threshold Input-High Voltage	V _{IH_FS}	3.3 V +/-5%	0.7		V _{DD} + 0.3	V	
Low Threshold Input-Low Voltage	V _{IL_FS}	3.3 V +/-5%	V _{SS} - 0.3		0.35	V	
Input Frequency	F _i			25.00		MHz	2
Pin Inductance	L _{pin}				7	nH	1
Capacitance	C _{IN}	Logic Inputs			5	pF	1
	C _{OUT}	Output pin capacitance			5	pF	1
	C _{INX}	X1 & X2 pins			5	pF	1
Clk Stabilization	T _{STAB}	From V _{DD} Power-Up and after input clock stabilization or de-assertion of PD# to 1st clock			1.8	ms	2
Tdrive_PD#	t _{DRVPD}	Differential output enable after PD# de-assertion			300	us	1,3
Tfall	t _F	Fall time of control inputs			5	ns	1,2
Trise	t _R	Rise time of control inputs			5	ns	1,2
SMBus Input Low Voltage	V _{ILSMB}				0.8	V	
SMBus Input High Voltage	V _{IHSMB}		2.1		V _{DD} SMB	V	
SMBus Output Low Voltage	V _{OLSMB}	@ I _{PULLUP}			0.4	V	
SMBus Sink Current	I _{PULLUP}	@ V _{OL}	4			mA	
Nominal Bus Voltage	V _{DD} SMB	3V to 5V +/- 10%	2.7		5.5	V	1
SCLK/SDATA Rise Time	t _{RSMB}	(Max V _{IL} - 0.15) to (Min V _{IH} + 0.15)			1000	ns	1
SCLK/SDATA Fall Time	t _{FSMB}	(Min V _{IH} + 0.15) to (Max V _{IL} - 0.15)			300	ns	1
SMBus Operating Frequency	f _{SMB}	SMBus operating frequency	400			kHz	

¹Guaranteed by design and characterization, not 100% tested in production.

²Control input must be monotonic from 20% to 80% of input swing.

³Time from deassertion until outputs are >200 mV

DC Electrical Characteristics—CPU, SRC, NS_SAS, NS_SRC, DOT96 LP-HCSL Outputs

TA = T_{AMB}; Supply Voltage VDDx = 3.3 V +/-5%

PARAMETER	SYMBOL	CONDITIONS	MIN	TYP	MAX	UNITS	NOTES
Slew rate	dV/dt	Scope averaging on	2	3.3	4.5	V/ns	1, 2, 3
Slew rate matching	Δ dV/dt	Slew rate matching, Scope averaging on		11.1	20	%	1, 2, 4
Rise/Fall Time Matching	Δ Trf	Rise/fall matching, Scope averaging off		9.0	125	ps	1, 8, 9
Voltage High	VHigh	Statistical measurement on single-ended signal using oscilloscope math function. (Scope averaging on)	660	845	850	mV	
Voltage Low	VLow		-150	122	150		
Max Voltage	Vmax	Measurement on single ended signal using absolute value.		1026	1150	mV	1, 7
Min Voltage	Vmin		-300	-22			1, 7
Crossing Voltage (abs)	Vcross_abs	Scope averaging off	250	482	550	mV	1, 5
Crossing Voltage (var)	Δ -Vcross	Scope averaging off		22	140	mV	1, 6

¹Guaranteed by design and characterization, not 100% tested in production. Z_O=85 Ω (differential impedance).

² Measured from differential waveform

³ Slew rate is measured through the Vswing voltage range centered around differential 0V. This results in a +/-150mV window around differential 0V.

⁴ Matching applies to rising edge rate for Clock and falling edge rate for Clock#. It is measured using a +/-75mV window centered on the average cross point where Clock rising meets Clock# falling. The median cross point is used to calculate the voltage thresholds the oscilloscope is to use for the edge rate calculations.

⁵ Vcross is defined as voltage where Clock = Clock# measured on a component test board and only applies to the differential rising edge (i.e. Clock rising and Clock# falling).

⁶ The total variation of all Vcross measurements in any particular system. Note that this is a subset of V_cross_min/max (V_cross absolute) allowed. The intent is to limit Vcross induced modulation by setting V_cross_delta to be smaller than

⁷ Includes overshoot and undershoot.

⁸ Measured from single-ended waveform

⁹ Measured with scope averaging off, using statistics function. Variation is difference between min and max.

Electrical Characteristics—48MHz

TA = T_{AMB}; Supply Voltage VDDx = 3.3 V +/-5%

PARAMETER	SYMBOL	CONDITIONS	MIN	TYP	MAX	UNITS	NOTES
Output High Voltage	V _{OH}	I _{OH} = -1 mA	2.4			V	
Output Low Voltage	V _{OL}	I _{OL} = 1 mA			0.55	V	
Clock High Time	T _{HIGH}	1.5V	8.094		10.036	ns	1
Clock Low Time	T _{LOW}	1.5V	7.694		9.836	ns	1
Edge Rate	t _{slewr/f USB}	Rising/Falling edge rate	1	1.7	2	V/ns	1,2
Duty Cycle	d _{t1}	V _T = 1.5 V	45	50.4	55	%	1
Jitter, Cycle to cycle	t _{jycyc-cyc}	V _T = 1.5 V		29	250	ps	1

See "Power Supply and Test Loads" page for termination circuits

¹Guaranteed by design and characterization, not 100% tested in production.

² Measured between 0.8V and 2.0V

Electrical Characteristics–PCI

TA = T_{AMB}; Supply Voltage VDDx = 3.3 V +/-5%

PARAMETER	SYMBOL	CONDITIONS	MIN	TYP	MAX	UNITS	NOTES
Output High Voltage	V _{OH}	I _{OH} = -1 mA	2.4			V	
Output Low Voltage	V _{OL}	I _{OL} = 1 mA			0.55	V	
Clock High Time	T _{HIGH}	1.5V	12			ns	1
Clock Low Time	T _{LOW}	1.5V	12			ns	1
Edge Rate	t _{slwrf}	Rising/Falling edge rate	1	1.7	4	V/ns	1,2
Duty Cycle	d _{t1}	V _T = 1.5 V	45	50.6	55	%	1
Group Skew	t _{skew}	V _T = 1.5 V		496	550	ps	1
Jitter, Cycle to cycle	t _{jcc-cyc}	V _T = 1.5 V		23	250	ps	1

See "Power Supply and Test Loads" page for termination circuits

¹Guaranteed by design and characterization, not 100% tested in production.

² Measured between 0.8V and 2.0V

Electrical Characteristics–Phase Jitter Parameters

TA = T_{AMB}; Supply Voltage VDDx = 3.3 V +/-5%

PARAMETER	SYMBOL	CONDITIONS	MIN	TYP	MAX	IND. LIMIT	UNITS	Notes	
Phase Jitter	t _{jphPCIeG1}	PCIe Gen 1		24.8	30	86	ps (p-p)	1,2,3,6	
	t _{jphPCIeG2}	PCIe Gen 2 Lo Band 10kHz < f < 1.5MHz		0.54	0.7	3	ps (rms)	1,2,6	
		PCIe Gen 2 High Band 1.5MHz < f < Nyquist (50MHz)		2.2	2.6/3	3.1	ps (rms)	1,2,6	
	t _{jphPCIeG3Com}	PCIe Gen 3 Common Clock (PLL BW of 2-4MHz. CDR = 10MHz)		0.46	0.6	1	ps (rms)	1,2,4,6	
	t _{jphPCIeG3SRns}	PCIe Gen 3 Separate Reference no Spread (SRnS) (PLL BW of 2-4MHz. CDR = 10MHz)		0.46	0.6	0.7	ps (rms)	1,2,4,6	
	t _{jphQPI_SMI}	QPI & SMI (100MHz, 4.8Gb/s, 6.4Gb/s 12UI)			0.24	0.4	0.5	ps (rms)	1,5,6
		QPI & SMI (100MHz, 8.0Gb/s, 12UI)			0.13	0.15	0.3	ps (rms)	1,5,6
		QPI & SMI (100MHz, 9.6Gb/s, 12UI)			0.11	0.13	0.2	ps (rms)	1,5,6
t _{jphSAS12G}	SAS 12G		0.84	1.1/1.2	1.3	ps (rms)	1,5,6		

¹ Guaranteed by design and characterization, not 100% tested in production.

² See <http://www.pcisig.com> for complete specs

³ Sample size of at least 100K cycles. This figures extrapolates to 108ps pk-pk @ 1M cycles for a BER of 1-12.

⁴ Subject to final radification by PCI SIG.

⁵ Calculated from Intel-supplied Clock Jitter Tool v 1.6.6

⁶ Applied to SRC, CPU and NS_SRC, NS_SAS outputs, second figure if present applies to -40C.

Electrical Characteristics–REF14M

TA = T_{AMB}; Supply Voltage VDDx = 3.3 V +/-5%

PARAMETER	SYMBOL	CONDITIONS	MIN	TYP	MAX	UNITS	Notes
Output High Voltage	V _{OH}	I _{OH} = -1 mA	2.4			V	
Output Low Voltage	V _{OL}	I _{OL} = 1 mA			0.55	V	
Clock High Time	T _{HIGH}	1.5V	27.5			ns	1
Clock Low Time	T _{LOW}	1.5V	27.5			ns	1
Edge Rate	t _{slewr/f}	Rising/Falling edge rate	1	1.9	4	V/ns	1,2
Duty Cycle	d _{t1}	V _T = 1.5 V	45	50.2	55	%	1
Jitter, Cycle to cycle	t _{jyc-cyc}	V _T = 1.5 V		19	250	ps	1

See "Power Supply and Test Loads" page for termination circuits

¹Guaranteed by design and characterization, not 100% tested in production.

² Measured between 0.8V and 2.0V

Test Clarification Table

Comments	HW		SW		OUTPUT
	TEST_SEL HW PIN	TEST_MOD E HW PIN	TEST ENTRY BIT B6b6	REF/N or HI-Z B6b7	
	0	X	0	X	NORMAL
Power-up w/ TEST_SEL = 1 (>0.7V) to enter test mode. TEST_SEL is low threshold input . Cycle power to disable test mode.	1	0	X	0	HI-Z
	1	0	X	1	REF/N
	1	1	X	0	REF/N
	1	1	X	1	REF/N
If TEST_SEL HW pin is 0 during power-up, test mode can be selected through B6b6. If test mode is selected by B6b6, then B6b7 is used to select HI-Z or REF/N. FS_B/TEST_Mode pin is not used. Cycle power to disable test mode.	0	X	1	0	HI-Z
	0	X	1	1	REF/N

B6b6: 1= ENTER TEST MODE, Default = 0 (NORMAL OPERATION)

B6b7: 1= REF/N, Default = 0 (HI-Z)

General SMBus Serial Interface Information for 932SQL456

How to Write

- Controller (host) sends a start bit
- Controller (host) sends the write address
- IDT clock will **acknowledge**
- Controller (host) sends the beginning byte location = N
- IDT clock will **acknowledge**
- Controller (host) sends the byte count = X
- IDT clock will **acknowledge**
- Controller (host) starts sending Byte **N through Byte N+X-1**
- IDT clock will **acknowledge** each byte **one at a time**
- Controller (host) sends a Stop bit

Index Block Write Operation			
Controller (Host)		IDT (Slave/Receiver)	
T	starT bit		
Slave Address D2 _(H)			
WR	WRite		
		ACK	
Beginning Byte = N			
		ACK	
Data Byte Count = X			
		ACK	
Beginning Byte N		X Byte	
			ACK
O			O
O			O
O		O	
Byte N + X - 1			
		ACK	
P	stoP bit		

How to Read

- Controller (host) will send a start bit
- Controller (host) sends the write address
- IDT clock will **acknowledge**
- Controller (host) sends the beginning byte location = N
- IDT clock will **acknowledge**
- Controller (host) will send a separate start bit
- Controller (host) sends the read address
- IDT clock will **acknowledge**
- IDT clock will send the data byte count = X
- IDT clock sends Byte **N+X-1**
- IDT clock sends **Byte 0 through Byte X (if X_(H) was written to Byte 8)**
- Controller (host) will need to acknowledge each byte
- Controller (host) will send a not acknowledge bit
- Controller (host) will send a stop bit

Index Block Read Operation		
Controller (Host)		IDT (Slave/Receiver)
T	starT bit	
Slave Address D2 _(H)		
WR	WRite	
		ACK
Beginning Byte = N		
		ACK
RT	Repeat starT	
Slave Address D3 _(H)		
RD	ReaD	
		ACK
		Data Byte Count=X
ACK		
		Beginning Byte N
ACK		
O		O
O		O
O		O
		Byte N + X - 1
N	Not acknowledge	
P	stoP bit	

Read Address	Write Address
D3 _(H)	D2 _(H)

NOTE: Pin numbers refer to TSSOP**SMBus Table: Output Enable Register**

Byte 0	Pin #	Name	Control Function	Type	0	1	Default
Bit 7	24/25	DOT96 Enable	Output Enable	RW	Disable-Low/Low	Enable	1
Bit 6	50/49	NS_SAS1 Enable	Output Enable	RW	Disable-Low/Low	Enable	1
Bit 5	48/47	NS_SAS0 Enable	Output Enable	RW	Disable-Low/Low	Enable	1
Bit 4	44/43	NS_SRC1 Enable	Output Enable	RW	Disable-Low/Low	Enable	1
Bit 3	42/41	NS_SRC0 Enable	Output Enable	RW	Disable-Low/Low	Enable	1
Bit 2	36/35	SRC2 Enable	Output Enable	RW	Disable-Low/Low	Enable	1
Bit 1	34/33	SRC1 Enable	Output Enable	RW	Disable-Low/Low	Enable	1
Bit 0	30/31	SRC0 Enable	Output Enable	RW	Disable-Low/Low	Enable	1

SMBus Table: Output Enable Register

Byte 1	Pin #	Name	Control Function	Type	0	1	Default
Bit 7	5	REF14_2x Enable	Output Enable	RW	Disable-Low	Enable	1
Bit 6		RESERVED					0
Bit 5		RESERVED					0
Bit 4	62/61	CPU3	Output Enable	RW	Disable-Low/Low	Enable	1
Bit 3	60/59	CPU2	Output Enable	RW	Disable-Low/Low	Enable	1
Bit 2	56/55	CPU1	Output Enable	RW	Disable-Low/Low	Enable	1
Bit 1	54/53	CPU0	Output Enable	RW	Disable-Low/Low	Enable	1
Bit 0		RESERVED					0

SMBus Table: Output Enable Register

Byte 2	Pin #	Name	Control Function	Type	0	1	Default
Bit 7		RESERVED					0
Bit 6		RESERVED					0
Bit 5	13	PCI4 Enable	Output Enable	RW	Disable-Low	Enable	1
Bit 4	14	PCI3 Enable	Output Enable	RW	Disable-Low	Enable	1
Bit 3	15	PCI2 Enable	Output Enable	RW	Disable-Low	Enable	1
Bit 2	16	PCI1 Enable	Output Enable	RW	Disable-Low	Enable	1
Bit 1	17	PCI0 Enable	Output Enable	RW	Disable-Low	Enable	1
Bit 0	21	48MHz Enable	Output Enable	RW	Disable-Low	Enable	1

SMBus Table: Differential Amplitude Control

Byte 3	Pin #	Name	Control Function	Type	0	1	Default
Bit 7		CPU AMPLITUDE 1	CPU Vhigh	RW	00 = 700mV	01 = 800mV	0
Bit 6		CPU AMPLITUDE 0		RW	10 = 900mV	11 = 1000mV	1
Bit 5		SRC AMPLITUDE 1	SRC Vhigh	RW	00 = 700mV	01 = 800mV	0
Bit 4		SRC AMPLITUDE 0		RW	10 = 900mV	11 = 1000mV	1
Bit 3		DOT96 AMPLITUDE 1	DOT96 Vhigh	RW	00 = 700mV	01 = 800mV	0
Bit 2		DOT96 AMPLITUDE 0		RW	10 = 900mV	11 = 1000mV	1
Bit 1		NS-SAS/SRC AMPLITUDE 1	NS-SAS/SRC Vhigh	RW	00 = 700mV	01 = 800mV	0
Bit 0		NS-SAS/SRC AMPLITUDE 0		RW	10 = 900mV	11 = 1000mV	1

SMBus Table: Reserved

Byte 4	Pin #	Name	Control Function	Type	0	1	Default
Bit 7		RESERVED					0
Bit 6		RESERVED					0
Bit 5		RESERVED					0
Bit 4		RESERVED					0
Bit 3		RESERVED					0
Bit 2		RESERVED					0
Bit 1		RESERVED					1
Bit 0		RESERVED					1

SMBus Table: Reserved

Byte 5	Pin #	Name	Control Function	Type	0	1	Default
Bit 7			RESERVED				0
Bit 6			RESERVED				0
Bit 5			RESERVED				0
Bit 4			RESERVED				0
Bit 3			RESERVED				0
Bit 2			RESERVED				1
Bit 1			RESERVED				1
Bit 0			RESERVED				1

SMBus Table: Test Mode and CPU/SRC/PCI Frequency Select Register

Byte 6	Pin #	Name	Control Function	Type	0	1	Default
Bit 7	-	Test Mode	Test Mode Type	RW	Hi-Z	REF/N	0
Bit 6	-	Test Select	Select Test Mode	RW	Disable	Enable	0
Bit 5	-		RESERVED				0
Bit 4	-		RESERVED				1
Bit 3	-		RESERVED				0
Bit 2	-		RESERVED				0
Bit 1	-		RESERVED				1
Bit 0	-		RESERVED				1

SMBus Table: Vendor & Revision ID Register

Byte 7	Pin #	Name	Control Function	Type	0	1	Default
Bit 7	-	RID3	REVISION ID (10h for A rev)	R	0 for A rev		0
Bit 6	-	RID2		R			0
Bit 5	-	RID1		R			0
Bit 4	-	RID0		R			0
Bit 3	-	VID3	VENDOR ID	R	0001 for ICS/IDT		0
Bit 2	-	VID2		R			0
Bit 1	-	VID1		R			0
Bit 0	-	VID0		R			1

SMBus Table: Byte Count Register

Byte 8	Pin #	Name	Control Function	Type	0	1	Default
Bit 7	-	BC7	Byte Count Programming b(7:0)	RW	Writing to this register will configure how many bytes will be read back, default is A bytes. (0 to 9)		0
Bit 6	-	BC6		RW			0
Bit 5	-	BC5		RW			0
Bit 4	-	BC4		RW			0
Bit 3	-	BC3		RW			0
Bit 2	-	BC2		RW			0
Bit 1	-	BC1		RW			0
Bit 0	-	BC0		RW			1

SMBus Table: Device ID Register

Byte 9	Pin #	Name	Control Function	Type	0	1	Default
Bit 7		DID7	Device ID (46 hex)	R	-	-	0
Bit 6		DID6		R	-	-	1
Bit 5		DID5		R	-	-	0
Bit 4		DID4		R	-	-	0
Bit 3		DID3		R	-	-	0
Bit 2		DID2		R	-	-	1
Bit 1		DID1		R	-	-	1
Bit 0		DID0		R	-	-	0

Recommended Crystal Characteristics (3225 package)

PARAMETER	VALUE	UNITS	NOTES
Frequency	25	MHz	1
Resonance Mode	Fundamental	-	1
Frequency Tolerance @ 25°C	±20	PPM Max	1
Frequency Stability, ref @ 25°C Over Operating Temperature Range	±20	PPM Max	1
Temperature Range (commercial)	0~70	°C	1
Temperature Range (industrial)	-40~85	°C	2
Equivalent Series Resistance (ESR)	50	Ω Max	1
Shunt Capacitance (C _O)	7	pF Max	1
Load Capacitance (C _L)	8	pF Max	1
Drive Level	0.3	mW Max	1
Aging per year	±5	PPM Max	1

Notes:

1. IDT 603-25-150JA4C or 603-25-150JA4I

Marking Diagrams



64TSSOP

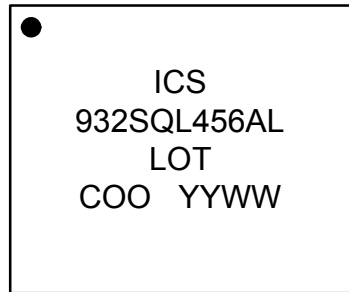

64VFQFPN



64TSSOP

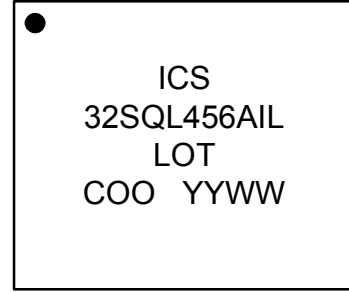

64VFQFPN

Notes:

1. "L" denotes Pb-free, RoHS compliant.
2. "LOT" denotes the lot number.
3. "YYWW" denotes the last two digits and week the part was assembled.
4. "COO" denotes the country of origin.
5. "A" denotes the device revision designator.
6. Bottom marking (TSSOP only): country of origin.

Package Outline and Package Dimensions (64-pin TSSOP)

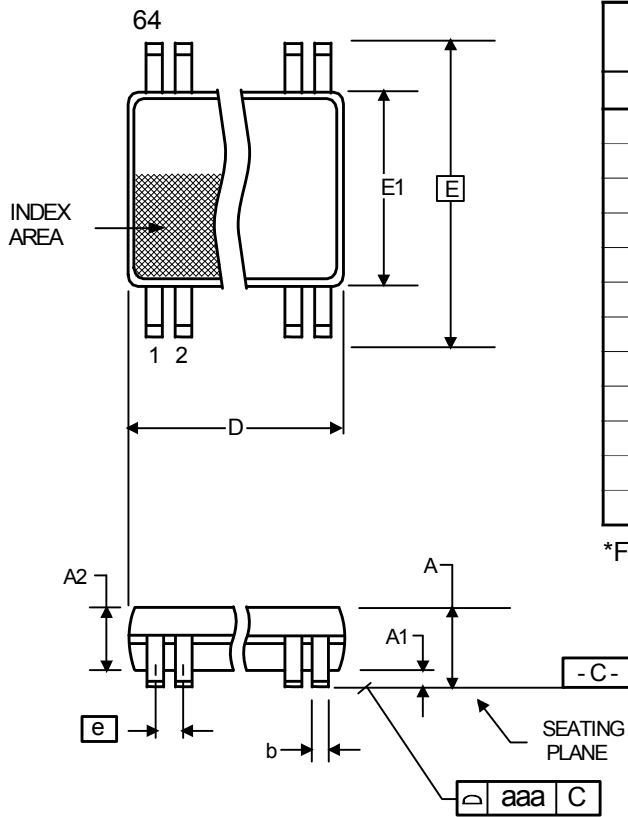

Symbol	Millimeters		Inches*	
	Min	Max	Min	Max
A	–	1.20	–	.047
A1	0.05	0.15	.002	.006
A2	0.80	1.05	0.32	0.41
b	0.17	0.27	.007	.011
c	0.09	0.20	.0035	.008
D	16.90	17.10	.665	.673
E	8.10 BASIC		0.319 BASIC	
E1	6.00	6.20	.236	.244
e	0.50 BASIC		0.020 BASIC	
aaa	–	0.10	–	.004
L	0.45	0.75	.018	.030
a	0°	8°	0°	8°

*For reference only. Controlling dimensions in mm.

NLG64 Package Outline and Package Dimensions, cont. Use Option 2 dimensions table.

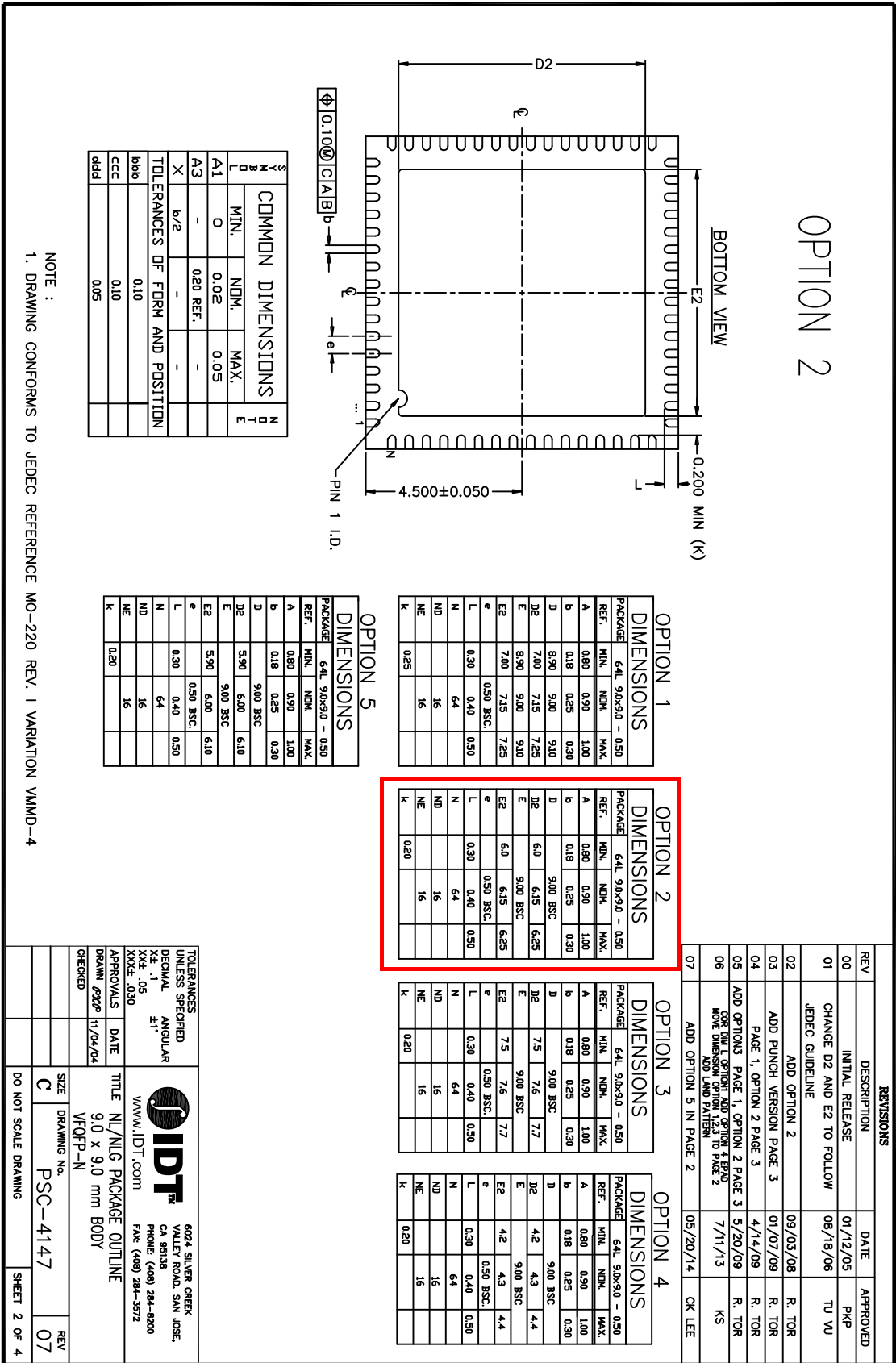

S	M	D	COMMON DIMENSIONS		N	D	T	E
			MIN.	MAX.				
A1	0	0.02	0.05					
A3	-	0.20 REF.	-					
X	b/2	-	-					

PACKAGE	64L 9.0x9.0 - 0.50
REF.	MIN. NOM. MAX.
A	0.80 0.90 1.00
b	0.18 0.25 0.30
D	8.90 9.00 9.10
D2	7.00 7.15 7.25
E	8.90 9.00 9.10
E2	7.00 7.15 7.25
e	0.50 BSC.
L	0.30 0.40 0.50
N	64
ND	16
NE	16
k	0.25

PACKAGE	64L 9.0x9.0 - 0.50
REF.	MIN. NOM. MAX.
A	0.80 0.90 1.00
b	0.18 0.25 0.30
D	8.90 9.00 9.10
D2	7.00 7.15 7.25
E	8.90 9.00 9.10
E2	7.00 7.15 7.25
e	0.50 BSC.
L	0.30 0.40 0.50
N	64
ND	16
NE	16
k	0.25

PACKAGE	64L 9.0x9.0 - 0.50
REF.	MIN. NOM. MAX.
A	0.80 0.90 1.00
b	0.18 0.25 0.30
D	8.90 9.00 9.10
D2	7.00 7.15 7.25
E	8.90 9.00 9.10
E2	7.00 7.15 7.25
e	0.50 BSC.
L	0.30 0.40 0.50
N	64
ND	16
NE	16
k	0.20

PACKAGE	64L 9.0x9.0 - 0.50
REF.	MIN. NOM. MAX.
A	0.80 0.90 1.00
b	0.18 0.25 0.30
D	8.90 9.00 9.10
D2	7.5 7.6 7.7
E	9.00 BSC.
E2	7.5 7.6 7.7
e	0.50 BSC.
L	0.30 0.40 0.50
N	64
ND	16
NE	16
k	0.20

PACKAGE	64L 9.0x9.0 - 0.50
REF.	MIN. NOM. MAX.
A	0.80 0.90 1.00
b	0.18 0.25 0.30
D	8.90 9.00 9.10
D2	4.2 4.3 4.4
E	9.00 BSC.
E2	4.2 4.3 4.4
e	0.50 BSC.
L	0.30 0.40 0.50
N	64
ND	16
NE	16
k	0.20

REVISIONS			
REV	DESCRIPTION	DATE	APPROVED
00	INITIAL RELEASE	01/12/05	PKP
01	CHANGE D2 AND E2 TO FOLLOW JEDEC GUIDELINE	08/18/06	TU VU
02	ADD OPTION 2	09/03/08	R. TOR
03	ADD PUNCH VERSION PAGE 3	01/07/09	R. TOR
04	PAGE 1, OPTION 2 PAGE 3	4/14/09	R. TOR
05	ADD OPTION3 PAGE 1, OPTION 2 PAGE 3	5/20/09	R. TOR
06	ADD DIMENSION OPTION 1, 2, 3 TO PAGE 2 ADD LAND PATTERN	7/11/13	KS
07	ADD OPTION 5 IN PAGE 2	05/20/14	CK LEE

NOTE :
1. DRAWING CONFORMS TO JEDEC REFERENCE MO-220 REV. 1 VARIATION VMMD-4

TOLERANCES UNLESS SPECIFIED	ANGULAR ±1°
DECIMAL XX.X	±0.05
XX.XX	±0.02
XX.XXX	±0.01



6024 SILVER CREEK
VALLEY ROAD, SAN JOSE,
CA 95138
PHONE: (408) 284-8200
FAX: (408) 284-5572

TITLE	NL/NLG PACKAGE OUTLINE
DRAWN	VFQFP-N
CHECKED	
DATE	11/04/04
APPROVALS	
SIZE	DRAWING No. PSC-4147
DO NOT SCALE DRAWING	
REV	07
SHEET	2 OF 4

NLG64 Package Outline and Package Dimensions, cont. Use EPAD 6.15 option

NOTES:

1. ALL DIMENSION ARE IN mm. ANGLES IN DEGREES.
2. TOP DOWN VIEW, AS VIEWED ON PCB.
3. LAND PATTERN IN BLUE, NSMD PATTERN ASSUMED.
4. LAND PATTERN RECOMMENDATION PER IPC-7351B LP CALCULATOR.

REVISIONS		
REV	DESCRIPTION	DATE
00	INITIAL RELEASE	01/12/05
01	CHANGE D2 AND E2 TO FOLLOW JEDEC GUIDELINE	08/18/06
02	ADD OPTION 2	09/03/08
03	ADD PUNCH VERSION PAGE 3	01/07/09
04	PAGE 1, OPTION 2 PAGE 3	4/14/09
05	ADD OPTION 3 PAGE 1, OPTION 2 PAGE 3	5/20/09
06	CORR DIM L OPTION 4 EPAD MOVE DIMENSION OPTION 1,2,3 TO PAGE 2 ADD LAND PATTERN	7/11/13
07	ADD OPTION 5 IN PAGE 2	05/20/14

TOLERANCES UNLESS SPECIFIED DECIMAL ANGULAR XX.X .05 XXXX. 0.30		6024 SILVER CREEK VALLEY ROAD, SAN JOSE, CA 95138 PHONE: (408) 284-8200 FAX: (408) 284-3572 WWW.IDT.COM
APPROVALS DRAWN <i>gkp</i> CHECKED	DATE 11/04/04	TITLE NLG64 PACKAGE OUTLINE 9.0 x 9.0 mm BODY VFQFP-N
SIZE C	DRAWING No. PSC-4147	REV 07
DO NOT SCALE DRAWING		SHEET 4 OF 4

Ordering Information

Part / Order Number	Shipping Packaging	Package	Temperature
932SQL456AGLF	Tubes	64-pin TSSOP	0 to +70° C
932SQL456AGLFT	Tape and Reel	64-pin TSSOP	0 to +70° C
932SQL456AKLF	Tray	64-pin VFQFPN	0 to +70° C
932SQL456AKLFT	Tape and Reel	64-pin VFQFPN	0 to +70° C
932SQL456AGILF	Tubes	64-pin TSSOP	-40 to +85° C
932SQL456AGILFT	Tape and Reel	64-pin TSSOP	-40 to +85° C
932SQL456AKILF	Tray	64-pin VFQFPN	-40 to +85° C
932SQL456AKILFT	Tape and Reel	64-pin VFQFPN	-40 to +85° C

"LF" suffix to the part number denotes Pb-Free configuration, RoHS6.6 compliant.

"A" is the device revision designator (will not correlate with the datasheet revision).

Revision History

Rev.	Issue Date	Who	Description	Page #
A	8/5/2015	RDW	<ol style="list-style-type: none"> 1. Updated front page text and data sheet title. 2. Updated REF14 pin name to reflect 2x drive. 3. Update pin description for REF14 pin. 4. Moved block diagram to page 1 and pinouts to page 2. 5. Updated block diagram to incorporate crystal recommendations. 6. Updated Clock AC tolerance to reflected tightened c2c jitter specs on single ended outputs. 7. Updated Clock periods table accordingly. 8. Updated AC/DC Electrical tables with char data. 9. Updated package drawing to latest format for NLG64. 10. Move to final and release. 	1-14,20
B	9/29/2015	RDW	<ol style="list-style-type: none"> 1. Added I-temp device to data sheet 2. Changed max power down current from 6mA to 8mA 3. Slight updates to PCIe Gen2 Hi-band and SAS12G for -40C 4. Corrected typo in bit name of Byte 1, bit 7. 5. Updated marking diagrams to include I-temp devices 6. Updated ordering information to include I-temp devices. 	1,9,12, 15,17, 22

IMPORTANT NOTICE AND DISCLAIMER

RENESAS ELECTRONICS CORPORATION AND ITS SUBSIDIARIES (“RENESAS”) PROVIDES TECHNICAL SPECIFICATIONS AND RELIABILITY DATA (INCLUDING DATASHEETS), DESIGN RESOURCES (INCLUDING REFERENCE DESIGNS), APPLICATION OR OTHER DESIGN ADVICE, WEB TOOLS, SAFETY INFORMATION, AND OTHER RESOURCES “AS IS” AND WITH ALL FAULTS, AND DISCLAIMS ALL WARRANTIES, EXPRESS OR IMPLIED, INCLUDING, WITHOUT LIMITATION, ANY IMPLIED WARRANTIES OF MERCHANTABILITY, FITNESS FOR A PARTICULAR PURPOSE, OR NON-INFRINGEMENT OF THIRD-PARTY INTELLECTUAL PROPERTY RIGHTS.

These resources are intended for developers who are designing with Renesas products. You are solely responsible for (1) selecting the appropriate products for your application, (2) designing, validating, and testing your application, and (3) ensuring your application meets applicable standards, and any other safety, security, or other requirements. These resources are subject to change without notice. Renesas grants you permission to use these resources only to develop an application that uses Renesas products. Other reproduction or use of these resources is strictly prohibited. No license is granted to any other Renesas intellectual property or to any third-party intellectual property. Renesas disclaims responsibility for, and you will fully indemnify Renesas and its representatives against, any claims, damages, costs, losses, or liabilities arising from your use of these resources. Renesas' products are provided only subject to Renesas' Terms and Conditions of Sale or other applicable terms agreed to in writing. No use of any Renesas resources expands or otherwise alters any applicable warranties or warranty disclaimers for these products.

(Disclaimer Rev.1.01)

Corporate Headquarters

TOYOSU FORESIA, 3-2-24 Toyosu,
Koto-ku, Tokyo 135-0061, Japan
www.renesas.com

Trademarks

Renesas and the Renesas logo are trademarks of Renesas Electronics Corporation. All trademarks and registered trademarks are the property of their respective owners.

Contact Information

For further information on a product, technology, the most up-to-date version of a document, or your nearest sales office, please visit www.renesas.com/contact-us/.

OUR CERTIFICATE

DiGi provide top-quality products and perfect service for customer worldwide through standardization, technological innovation and continuous improvement. DiGi through third-party certification, we strictly control the quality of products and services. Welcome your RFQ to

Email: Info@DiGi-Electronics.com



Tel: +00 852-30501935

RFQ Email: Info@DiGi-Electronics.com

DiGi is a global authorized distributor of electronic components.