

ISL9238CHRTZ-T7A Datasheet

www.digi-electronics.com

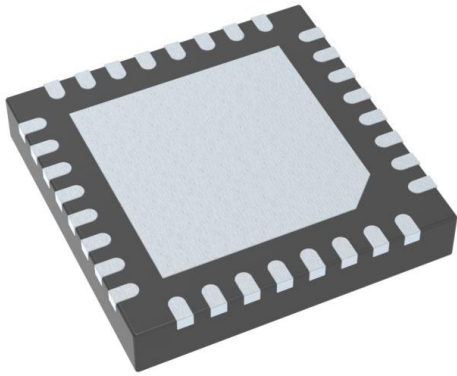

<https://www.DiGi-Electronics.com>

DiGi Electronics Part Number	ISL9238CHRTZ-T7A-DG
Manufacturer	Renesas Electronics Corporation
Manufacturer Product Number	ISL9238CHRTZ-T7A
Description	IC BATT CHG LI-ION 2-4CEL 32TQFN
Detailed Description	Charger IC Lithium Ion/Polymer 32-TQFN (4x4)

This model ISL9238CHRTZ-T7A is available at DiGi Electronics.

DiGi Electronics offers a global database of semiconductor and electronic component datasheets.

We welcome your inquiries regarding pricing, lead time, or other product-related questions.

 [Request a Quote](#)

 [Datasheet Search](#)



Tel: +00 852-30501935

RFQ Email: Info@DiGi-Electronics.com

DiGi is a global authorized distributor of electronic components.

Purchase and inquiry

Manufacturer Product Number:

ISL9238CHRTZ-T7A

Series:

-

Battery Chemistry:

Lithium Ion/Polymer

Current - Charging:

Constant - Programmable

Fault Protection:

Over Current, Over Temperature

Battery Pack Voltage:

2.4V ~ 18.304V

Interface:

I2C, SMBus

Mounting Type:

Surface Mount

Supplier Device Package:

32-TQFN (4x4)

Manufacturer:

Renesas Electronics Corporation

Product Status:

Active

Number of Cells:

2 ~ 4

Programmable Features:

Current

Charge Current - Max:

-

Voltage - Supply (Max):

23.4V

Operating Temperature:

-

Package / Case:

32-WFQFN Exposed Pad

Base Product Number:

ISL9238

Environmental & Export classification

RoHS Status:

ROHS3 Compliant

REACH Status:

REACH Unaffected

HTSUS:

8542.39.0001

Moisture Sensitivity Level (MSL):

3 (168 Hours)

ECCN:

EAR99

ISL9238C

Buck-Boost Narrow VDC Battery Charger with SMBus Interface and USB OTG

The [ISL9238C](#) is a buck-boost Narrow Output Voltage DC (NVDC) charger. The ISL9238C provides NVDC charging, system bus regulation, and protection features for tablets, Ultrabooks, notebooks, power banks, and any USB-C interface platform. The advanced Renesas R3™ technology provides high light-load efficiency and fast transient response.

In Charging mode, the ISL9238C accepts input power from a wide range of DC power sources (such as conventional AC/DC charger adapters, USB PD ports, and travel adapters) and safely charges battery packs with up to 4-series cell Li-ion batteries.

As an NVDC topology charger, the ISL9238C also regulates the system output to a narrow DC range for stable system bus voltage. System power can be provided from the adapter, battery, or a combination of both. The ISL9238C can operate with only a battery, only an adapter, or with both connected. For Intel IMVP8 compliant systems, the ISL9238C includes PSYS (system power monitor) functionality, which provides an analog signal representing total platform power. The PSYS output connects to a wide range of Renesas IMVP8 core regulators to provide an IMVP8 compliant power domain function.

The ISL9238C supports reverse buck, boost, or buck-boost operation to the input port from 2- to 4-cell batteries.

The ISL9238C provides SMBus/I²C serial communication that allows programming of many critical parameters to deliver a customized solution.

Features

- Buck-boost NVDC charger for 2-, 3-, or 4-cell Li-ion batteries
- Input voltage range: 3.9V to 23.4V (no dead zone)
- System output voltage: 2.4V to 18.304V
- Autonomous charging option (automatic completion of charging)
- Pass-Through mode in forward direction
- System power monitor PSYS output, IMVP compliant
- Up to 1MHz switching frequency
- Adapter current and battery current monitor (AMON/BMON)
- PROCHOT# open-drain output, IMVP compliant
- Allows trickle charging of depleted battery
- Ideal diode control in Turbo mode
- Reverse buck, boost, and buck-boost operation from battery
- Two-level adapter current limit available
- 100% 2-FET Buck only mode option
- Battery Ship mode option
- SMBus and auto-increment I²C compatible
- 4x4 32 Ld TQFN package
- UL2367, IEC 62368-1: File No. E520109

Applications

- 2- to 4-cell tablets, Ultrabooks, notebooks, power banks, and any USB-C interface portable device requiring batteries

ISL9238C Short-Form Datasheet

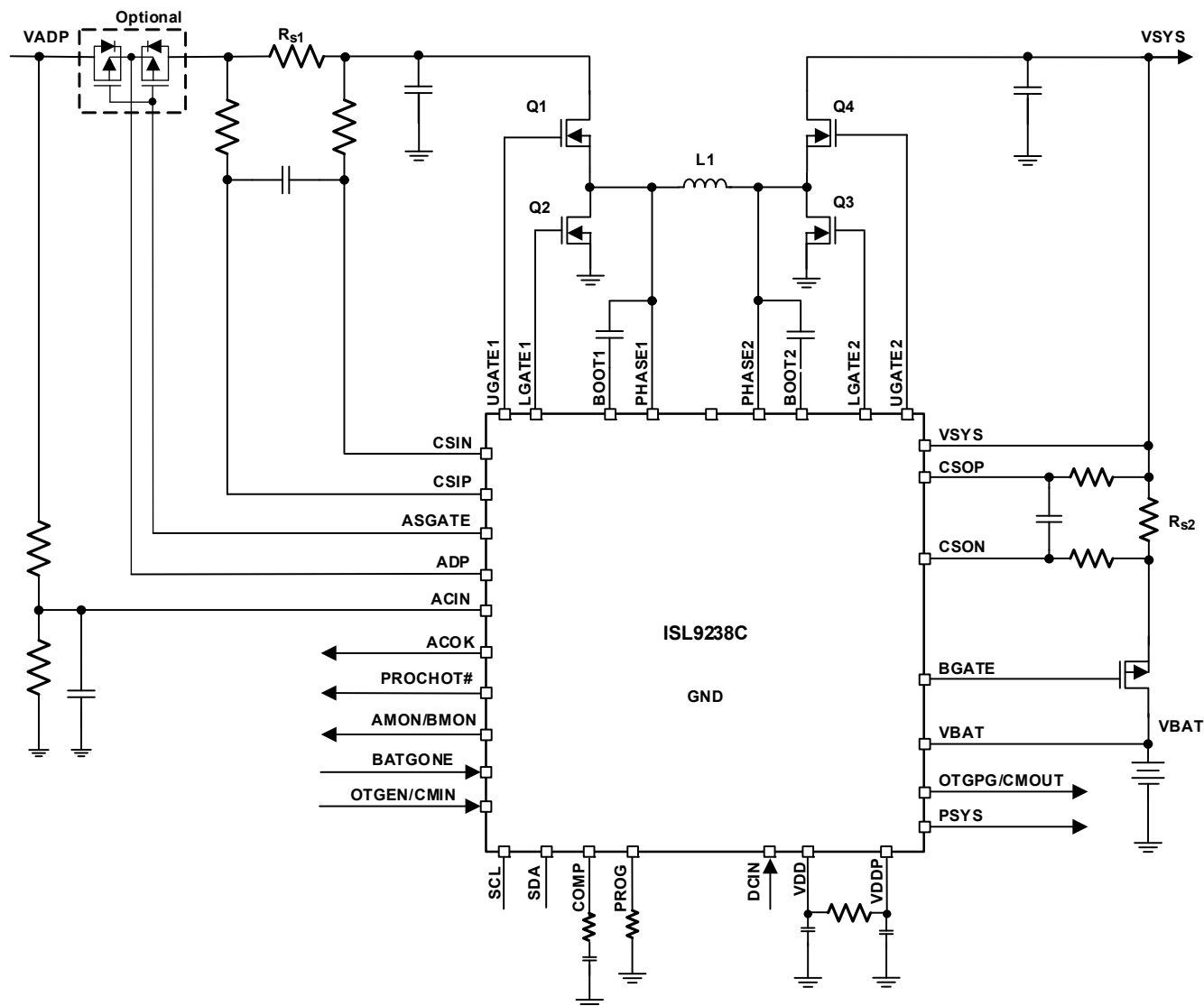

Figure 1. Typical Application Circuit

IMPORTANT NOTICE AND DISCLAIMER

RENESAS ELECTRONICS CORPORATION AND ITS SUBSIDIARIES (“RENESAS”) PROVIDES TECHNICAL SPECIFICATIONS AND RELIABILITY DATA (INCLUDING DATASHEETS), DESIGN RESOURCES (INCLUDING REFERENCE DESIGNS), APPLICATION OR OTHER DESIGN ADVICE, WEB TOOLS, SAFETY INFORMATION, AND OTHER RESOURCES “AS IS” AND WITH ALL FAULTS, AND DISCLAIMS ALL WARRANTIES, EXPRESS OR IMPLIED, INCLUDING, WITHOUT LIMITATION, ANY IMPLIED WARRANTIES OF MERCHANTABILITY, FITNESS FOR A PARTICULAR PURPOSE, OR NON-INFRINGEMENT OF THIRD-PARTY INTELLECTUAL PROPERTY RIGHTS.

These resources are intended for developers who are designing with Renesas products. You are solely responsible for (1) selecting the appropriate products for your application, (2) designing, validating, and testing your application, and (3) ensuring your application meets applicable standards, and any other safety, security, or other requirements. These resources are subject to change without notice. Renesas grants you permission to use these resources only to develop an application that uses Renesas products. Other reproduction or use of these resources is strictly prohibited. No license is granted to any other Renesas intellectual property or to any third-party intellectual property. Renesas disclaims responsibility for, and you will fully indemnify Renesas and its representatives against, any claims, damages, costs, losses, or liabilities arising from your use of these resources. Renesas' products are provided only subject to Renesas' Terms and Conditions of Sale or other applicable terms agreed to in writing. No use of any Renesas resources expands or otherwise alters any applicable warranties or warranty disclaimers for these products.

(Disclaimer Rev.1.01)

Corporate Headquarters

TOYOSU FORESIA, 3-2-24 Toyosu,
Koto-ku, Tokyo 135-0061, Japan
www.renesas.com

Trademarks

Renesas and the Renesas logo are trademarks of Renesas Electronics Corporation. All trademarks and registered trademarks are the property of their respective owners.

Contact Information

For further information on a product, technology, the most up-to-date version of a document, or your nearest sales office, please visit www.renesas.com/contact-us/.

OUR CERTIFICATE

DiGi provide top-quality products and perfect service for customer worldwide through standardization, technological innovation and continuous improvement. DiGi through third-party certification, we stricly control the quality of products and services. Welcome your RFQ to

Email: Info@DiGi-Electronics.com



Tel: +00 852-30501935

RFQ Email: Info@DiGi-Electronics.com

DiGi is a global authorized distributor of electronic components.