

# TW8849AT-LA1-GE Datasheet



DiGi Electronics Part Number	TW8849AT-LA1-GE-DG
Manufacturer	<a href="#">Renesas Electronics Corporation</a>
Manufacturer Product Number	TW8849AT-LA1-GE
Description	VIDEO PROCESSOR WITH LVDS I/O, I
Detailed Description	Video Processor IC I2C 156-LQFP-EP (14x20) Package

<https://www.DiGi-Electronics.com>



Tel: +00 852-30501935

RFQ Email: [Info@DiGi-Electronics.com](mailto:Info@DiGi-Electronics.com)

DiGi is a global authorized distributor of electronic components.



## Purchase and inquiry

Manufacturer Product Number:

TW8849AT-LA1-GE

Series:

-

Function:

Processor

Standards:

-

Voltage - Supply:

1.8V ~ 3.3V

Package / Case:

156-LQFP Exposed Pad

Manufacturer:

Renesas Electronics Corporation

Product Status:

Active

Applications:

Professional Video

Control Interface:

I2C

Mounting Type:

Surface Mount

Supplier Device Package:

156-LQFP-EP (14x20)

## Environmental & Export classification

RoHS Status:

ROHS3 Compliant

Moisture Sensitivity Level (MSL):

3 (168 Hours)

## TW8849

### Video Processor with LVDS Interfaces, Image Enhancement, and Video Integrity Diagnostics

The TW8849 is a highly integrated LCD video processor that incorporates many of the features required to create a multipurpose LCD display system. These features include two LVDS Open LDI input interfaces, two separate high quality scaler and de-interlacer engines, as well as dual channel LVDS Open LDI output interfaces to drive up to 2 LCDs. The TW8849 can support input resolutions up to 1080p and can drive LCD panels at resolutions up to 1920x1080. The TW8849's video processing capability includes 10-bit per color image enhancement processing, arbitrary H/V scaling, panoramic scaling, image mirroring, image adjustment, black and white stretch, Automatic Contrast Adjustment, and smooth input switching. In addition, the TW8849 has image diagnostic capabilities to determine if the input video is corrupted or frozen. The feature set and versatility of this device makes it an ideal solution for all Automotive LCD display applications.

### Applications

- Automotive display
- Industrial/military displays
- Portable/consumer displays

### Related Literature

For a full list of related documents, visit our website:

- [TW8849](#) device page

### Features

#### LVDS Open-LDI Input Support

- Two single-channel LVDS open-LDI inputs, up to 104MHz for each channel
- Dual-channel LVDS open-LDI input, up to 150MHz in Dual mode (75MHz per channel)

#### LVDS Panel Support

- Supports single-channel LVDS panels up to 1920x720 resolution (104MHz)
- Supports dual-channel LVDS up to 1920x1080 resolution (150MHz)

#### Image Processing

- Two high-quality scalers with both up/down scaling support
- Supports programmable cropping of input video and graphics
- Automatic Contrast Adjustment (ACA) on one scaler path
- 10-bit per color processing
- 10-bit image enhancement processing and 10-bit Gamma correction

#### Clock Generation

- Spread spectrum PLL integrated to each scaler path
- Programmable modulation frequency and spread width

#### Miscellaneous

- Fast Mode plus I<sup>2</sup>C interface up to 1.2Mbps with zero hold time
- Up to four 10-bit PWMs
- GPIOs
- Pin swapping (MSB ↔ LSB)
- Two separate input measurement engines with continuous measurement capability
- Smooth input switching using shadow registers
- 1.2V internal operation
- 1.8/3.3V I/O support
- Single 27MHz crystal
- 156 Ld LQFP with exposed thermal pad
- TW8849AT-LA1-GE is [AEC-Q100](#) qualified

TW8849

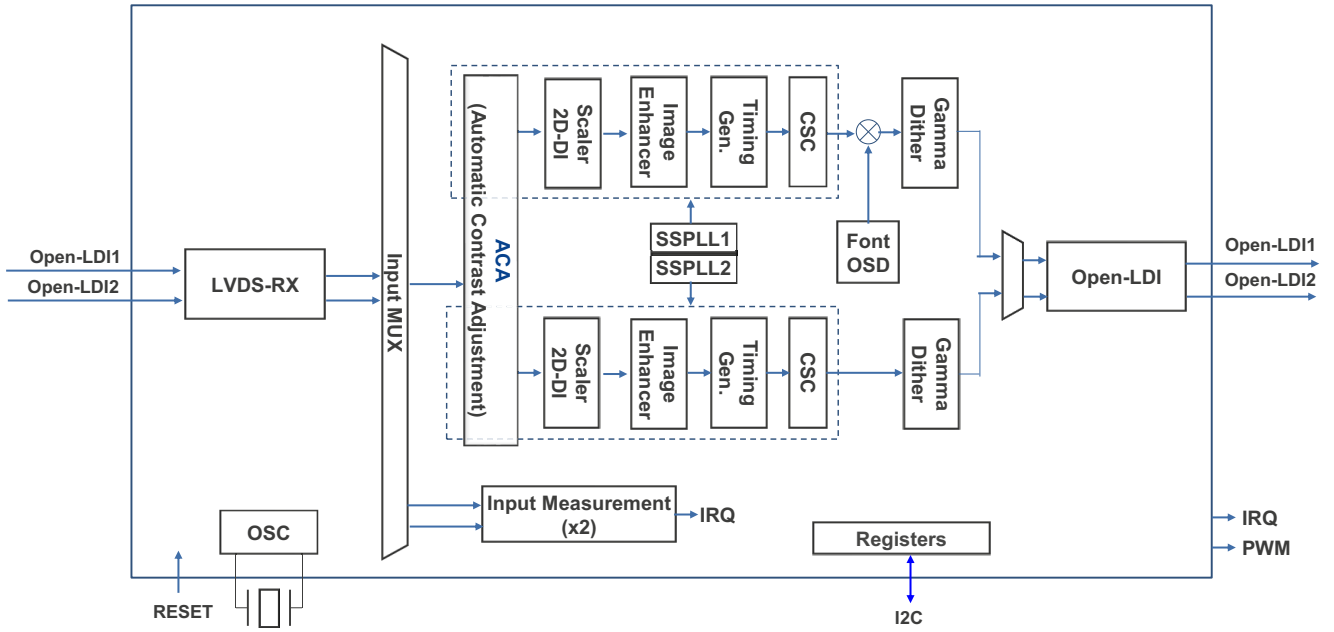

Figure 1. TW8849 Functional Block Diagram

## Notice

1. Descriptions of circuits, software and other related information in this document are provided only to illustrate the operation of semiconductor products and application examples. You are fully responsible for the incorporation or any other use of the circuits, software, and information in the design of your product or system. Renesas Electronics disclaims any and all liability for any losses and damages incurred by you or third parties arising from the use of these circuits, software, or information.
2. Renesas Electronics hereby expressly disclaims any warranties against and liability for infringement or any other claims involving patents, copyrights, or other intellectual property rights of third parties, by or arising from the use of Renesas Electronics products or technical information described in this document, including but not limited to, the product data, drawings, charts, programs, algorithms, and application examples.
3. No license, express, implied or otherwise, is granted hereby under any patents, copyrights or other intellectual property rights of Renesas Electronics or others.
4. You shall not alter, modify, copy, or reverse engineer any Renesas Electronics product, whether in whole or in part. Renesas Electronics disclaims any and all liability for any losses or damages incurred by you or third parties arising from such alteration, modification, copying or reverse engineering.
5. Renesas Electronics products are classified according to the following two quality grades: "Standard" and "High Quality". The intended applications for each Renesas Electronics product depends on the product's quality grade, as indicated below.
  - "Standard": Computers; office equipment; communications equipment; test and measurement equipment; audio and visual equipment; home electronic appliances; machine tools; personal electronic equipment; industrial robots; etc.
  - "High Quality": Transportation equipment (automobiles, trains, ships, etc.); traffic control (traffic lights); large-scale communication equipment; key financial terminal systems; safety control equipment; etc.

Unless expressly designated as a high reliability product or a product for harsh environments in a Renesas Electronics data sheet or other Renesas Electronics document, Renesas Electronics products are not intended or authorized for use in products or systems that may pose a direct threat to human life or bodily injury (artificial life support devices or systems; surgical implantations; etc.), or may cause serious property damage (space system; undersea repeaters; nuclear power control systems; aircraft control systems; key plant systems; military equipment; etc.). Renesas Electronics disclaims any and all liability for any damages or losses incurred by you or any third parties arising from the use of any Renesas Electronics product that is inconsistent with any Renesas Electronics data sheet, user's manual or other Renesas Electronics document.
6. When using Renesas Electronics products, refer to the latest product information (data sheets, user's manuals, application notes, "General Notes for Handling and Using Semiconductor Devices" in the reliability handbook, etc.), and ensure that usage conditions are within the ranges specified by Renesas Electronics with respect to maximum ratings, operating power supply voltage range, heat dissipation characteristics, installation, etc. Renesas Electronics disclaims any and all liability for any malfunctions, failure or accident arising out of the use of Renesas Electronics products outside of such specified ranges.
7. Although Renesas Electronics endeavors to improve the quality and reliability of Renesas Electronics products, semiconductor products have specific characteristics, such as the occurrence of failure at a certain rate and malfunctions under certain use conditions. Unless designated as a high reliability product or a product for harsh environments in a Renesas Electronics data sheet or other Renesas Electronics document, Renesas Electronics products are not subject to radiation resistance design. You are responsible for implementing safety measures to guard against the possibility of bodily injury, injury or damage caused by fire, and/or danger to the public in the event of a failure or malfunction of Renesas Electronics products, such as safety design for hardware and software, including but not limited to redundancy, fire control and malfunction prevention, appropriate treatment for aging degradation or any other appropriate measures. Because the evaluation of microcomputer software alone is very difficult and impractical, you are responsible for evaluating the safety of the final products or systems manufactured by you.
8. Please contact a Renesas Electronics sales office for details as to environmental matters such as the environmental compatibility of each Renesas Electronics product. You are responsible for carefully and sufficiently investigating applicable laws and regulations that regulate the inclusion or use of controlled substances, including without limitation, the EU RoHS Directive, and using Renesas Electronics products in compliance with all these applicable laws and regulations. Renesas Electronics disclaims any and all liability for damages or losses occurring as a result of your noncompliance with applicable laws and regulations.
9. Renesas Electronics products and technologies shall not be used for or incorporated into any products or systems whose manufacture, use, or sale is prohibited under any applicable domestic or foreign laws or regulations. You shall comply with any applicable export control laws and regulations promulgated and administered by the governments of any countries asserting jurisdiction over the parties or transactions.
10. It is the responsibility of the buyer or distributor of Renesas Electronics products, or any other party who distributes, disposes of, or otherwise sells or transfers the product to a third party, to notify such third party in advance of the contents and conditions set forth in this document.
11. This document shall not be reprinted, reproduced or duplicated in any form, in whole or in part, without prior written consent of Renesas Electronics.
12. Please contact a Renesas Electronics sales office if you have any questions regarding the information contained in this document or Renesas Electronics products.

(Note1) "Renesas Electronics" as used in this document means Renesas Electronics Corporation and also includes its directly or indirectly controlled subsidiaries.

(Note2) "Renesas Electronics product(s)" means any product developed or manufactured by or for Renesas Electronics.

(Rev.4.0-1 November 2017)

## Corporate Headquarters

TOYOSU FORESIA, 3-2-24 Toyosu,  
Koto-ku, Tokyo 135-0061, Japan  
[www.renesas.com](http://www.renesas.com)

## Contact Information

For further information on a product, technology, the most up-to-date version of a document, or your nearest sales office, please visit:  
[www.renesas.com/contact/](http://www.renesas.com/contact/)

## Trademarks

Renesas and the Renesas logo are trademarks of Renesas Electronics Corporation. All trademarks and registered trademarks are the property of their respective owners.



## OUR CERTIFICATE

DiGi provide top-quality products and perfect service for customer worldwide through standardization, technological innovation and continuous improvement. DiGi through third-party certification, we stricly control the quality of products and services. Welcome your RFQ to

Email: [Info@DiGi-Electronics.com](mailto:Info@DiGi-Electronics.com)



Tel: +00 852-30501935

RFQ Email: [Info@DiGi-Electronics.com](mailto:Info@DiGi-Electronics.com)

DiGi is a global authorized distributor of electronic components.