

RP109N221D-TR-FE Datasheet

www.digi-electronics.com

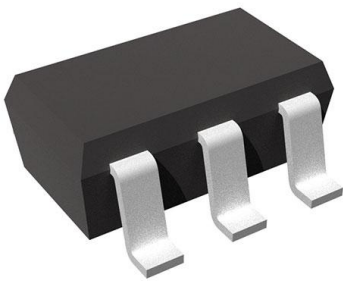

<https://www.DiGi-Electronics.com>

DiGi Electronics Part Number	RP109N221D-TR-FE-DG
Manufacturer	Nisshinbo Micro Devices Inc.
Manufacturer Product Number	RP109N221D-TR-FE
Description	IC REG LINEAR 2.2V 150MA SOT23-5
Detailed Description	Linear Voltage Regulator IC Positive Fixed 1 Output 150mA SOT-23-5



Tel: +00 852-30501935

RFQ Email: Info@DiGi-Electronics.com

DiGi is a global authorized distributor of electronic components.

Purchase and inquiry

Manufacturer Product Number:

RP109N221D-TR-FE

Series:

RP109x

Output Configuration:

Positive

Number of Regulators:

1

Voltage - Output (Min/Fixed):

2.2V

Voltage Dropout (Max):

0.4V @ 150mA

Current - Quiescent (Iq):

70 μ A

Control Features:

Enable

Operating Temperature:

-40°C ~ 85°C (TA)

Package / Case:

SC-74A, SOT-753

Base Product Number:

RP109

Manufacturer:

Nisshinbo Micro Devices Inc.

Product Status:

Active

Output Type:

Fixed

Voltage - Input (Max):

5.25V

Voltage - Output (Max):

-

Current - Output:

150mA

PSRR:

75dB (1kHz)

Protection Features:

Over Current

Mounting Type:

Surface Mount

Supplier Device Package:

SOT-23-5

Environmental & Export classification

RoHS Status:

RoHS Compliant

ECCN:

EAR99

Moisture Sensitivity Level (MSL):

1 (Unlimited)

HTSUS:

8542.39.0001



RP109x SERIES

LOW NOISE 150mA LDO REGULATOR

NO.EA-204-240515

OUTLINE

The RP109x Series are CMOS-based voltage regulator ICs with high output voltage accuracy, extremely low supply current, low ON-resistance, and high ripple rejection. Each of these ICs consists of a voltage reference unit, an error amplifier, a resistor-net for voltage setting, a current limit circuit and a chip enable circuit.

These ICs perform with low dropout voltage and a chip enable function which prolong the battery life.

The line transient response and load transient response of the RP109x Series are excellent, thus these ICs are very suitable for the power supply for hand-held communication equipment. RP109x Series contributes to the downsizing of the hand-held equipment because it can use the 0.1 μ F ceramic capacitor.

In addition to SOT-23-5, SC-88A and DFN1010-4 packages, a 0.8mm square ultra compact DFN(PL)0808-4 package is also available.

FEATURES

- Supply Current Typ. 50 μ A
- Standby Mode Typ. 0.1 μ A
- Dropout Voltage..... Typ. 0.25V ($I_{OUT}=150\text{mA}$, $V_{OUT}=2.5\text{V}$)
- Ripple Rejection Typ. 75dB ($f=1\text{kHz}$, $V_{OUT}=2.5\text{V}$)
- Temperature-Drift Coefficient of Output Voltage Typ. $\pm 100\text{ppm}/^\circ\text{C}$ ($V_{OUT}<1.8\text{V}$)
Typ. $\pm 30\text{ppm}/^\circ\text{C}$ ($V_{OUT}\geq 1.8\text{V}$)
- Line Regulation Typ. 0.02%/V
- Output Voltage Accuracy $\pm 1.0\%$
- Packages..... DFN(PL)0808-4, DFN1010-4, SC-88A, SOT-23-5
- Input Voltage Range..... 1.4V to 5.25V
- Output Voltage Range..... 0.8V to 3.6V (0.1V steps)
(For other voltages, please refer to MARK INFORMATION.)
- Built-in Fold Back Protection Circuit..... Typ. 40mA (Current at short mode)
- Ceramic capacitors are recommended to be used with this IC 0.1 μ F or more

APPLICATIONS

- Power source for portable communication equipment.
- Power source for electrical appliances such as cameras, VCRs and camcorders.
- Power source for battery-powered equipment.
- Power source for home appliances.

BLOCK DIAGRAMS

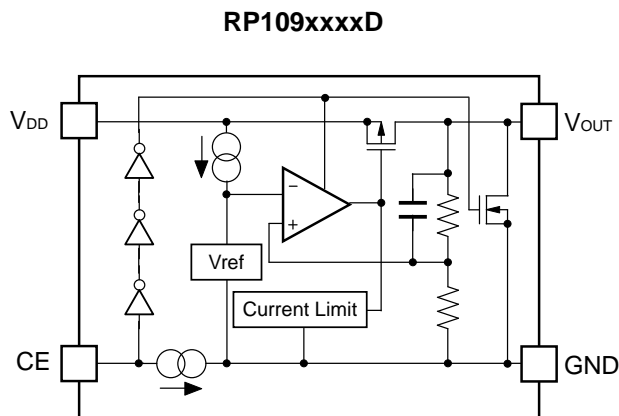
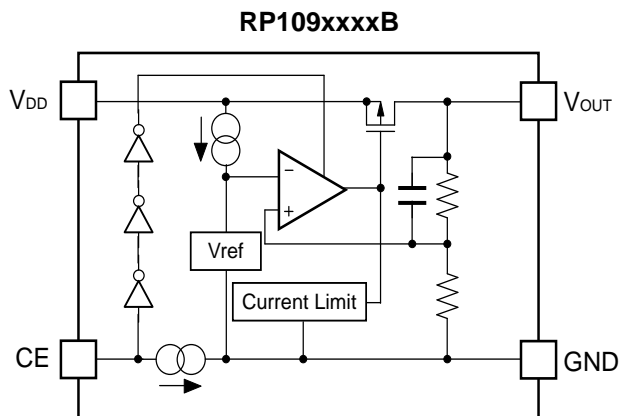

SELECTION GUIDE

The output voltage, auto discharge function, package, and the taping type, etc. for the ICs can be selected at the user's request.

Product Name	Package	Quantity per Reel	Pb Free	Halogen Free
RP109Kxx1*-TR	DFN(PL)0808-4	10,000 pcs	Yes	Yes
RP109Lxx1*-TR	DFN1010-4	10,000 pcs	Yes	Yes
RP109Qxx2*-TR-FE	SC-88A	3,000 pcs	Yes	Yes
RP109Nxx1*-TR-FE	SOT-23-5	3,000 pcs	Yes	Yes

xx: Specify the set output voltage (V_{SET}) within the range of 0.8V to 3.6 in 0.1V steps.

The second decimal point of V_{SET} is described as below.

1.25V: RP109x12x*5

1.85V: RP109x18x*5

2.85V: RP109x28x*5

*: Select the polarity of the CE pin from (B) "H" active without auto-discharge function or (D) "H" active with auto-discharge function.

PIN CONFIGURATIONS

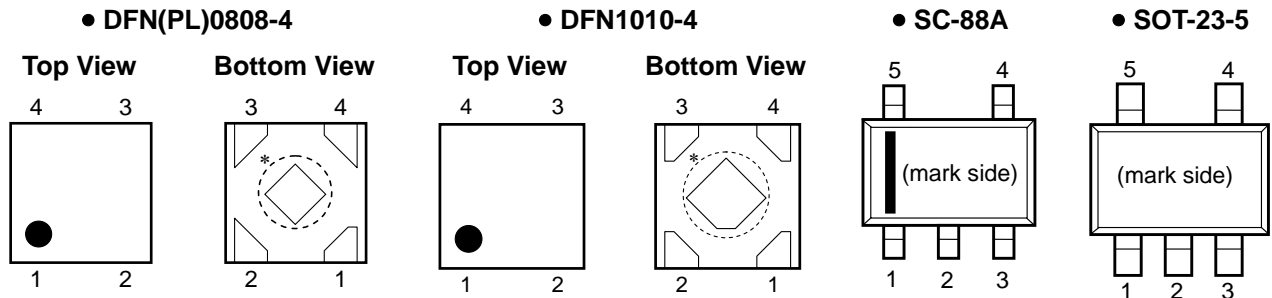

PIN DESCRIPTIONS

• DFN(PL)0808-4 / DFN1010-4

Pin No	Symbol	Pin Description
1	V_{OUT}	Output Pin
2	GND	Ground Pin
3	CE	Chip Enable Pin ("H" Active)
4	V_{DD}	Input Pin

* Tab is GND level. (They are connected to the reverse side of this IC.)

The tab is better to be connected to the GND, but leaving it open is also acceptable.

• SC-88A

Pin No	Symbol	Pin Description
1	CE	Chip Enable Pin ("H" Active)
2 *	NC	No Connection
3	GND	Ground Pin
4	V_{OUT}	Output Pin
5	V_{DD}	Input Pin

* Pin No. 2 is connected to the bottom of the IC. It is recommended that the pin be connected to the ground plane on the board, or otherwise be left floating so that there is no contact with other potentials.

• SOT-23-5

Pin No	Symbol	Pin Description
1	V_{DD}	Input Pin
2	GND	Ground Pin
3	CE	Chip Enable Pin ("H" Active)
4	NC	No Connection
5	V_{OUT}	Output Pin

ABSOLUTE MAXIMUM RATINGS

Symbol	Item	Rating	Unit
V_{IN}	Input Voltage	6.0	V
V_{CE}	Input Voltage (CE Pin)	-0.3 to 6.0	V
V_{OUT}	Output Voltage	-0.3 to $V_{IN}+0.3$	V
I_{OUT}	Output Current	180	mA
P_D	Power Dissipation* (DFN(PL)0808-4)	286	mW
	Power Dissipation* (DFN1010-4)	400	
	Power Dissipation* (SC-88A)	380	
	Power Dissipation* (SOT-23-5)	420	
T_a	Operating Temperature Range	-40 to 85	°C
T_{stg}	Storage Temperature Range	-55 to 125	°C

*) For Power Dissipation, please refer to PACKAGE INFORMATION.

ABSOLUTE MAXIMUM RATINGS

Electronic and mechanical stress momentarily exceeded absolute maximum ratings may cause the permanent damages and may degrade the life time and safety for both device and system using the device in the field.

The functional operation at or over these absolute maximum ratings is not assured.

ELECTRICAL CHARACTERISTICS

• RP109xxxxB/D

$V_{IN}=V_{SET}+1.0V$ ($V_{OUT}>1.5$), $V_{IN}=2.5V$ ($V_{OUT}\leq 1.5V$), $I_{OUT}=1mA$, $C_{IN}=C_{OUT}=0.1\mu F$, unless otherwise noted.

The specifications surrounded by are guaranteed by Design Engineering at $-40^{\circ}C \leq T_a \leq 85^{\circ}C$.

RP109x Series

($T_a=25^{\circ}C$)

Symbol	Item	Conditions	Min.	Typ.	Max.	Unit		
V_{OUT}	Output Voltage	$T_a = 25^{\circ}C$	$V_{SET} \geq 1.8V$	x 0.99		x 1.01	V	
			$V_{SET} < 1.8V$		-18		+18	mV
		$-40^{\circ}C \leq T_a \leq 85^{\circ}C$	$V_{SET} \geq 1.8V$	x 0.985			x 1.015	V
			$V_{SET} < 1.8V$		-50		+50	mV
I_{OUT}	Output Current		150			mA		
$\frac{\Delta V_{OUT}}{\Delta I_{OUT}}$	Load Regulation	$1mA \leq I_{OUT} \leq 150mA$		5	30	mV		
V_{DIF}	Dropout Voltage	Please see <i>Dropout Voltage</i> on the next page.						
I_{SS}	Supply Current	$I_{OUT} = 0mA$		50	70	μA		
$I_{standby}$	Supply Current (Standby Mode)	$V_{CE} = 0V$		0.1	1.0	μA		
$\frac{\Delta V_{OUT}}{\Delta V_{IN}}$	Line Regulation	$V_{SET}+0.5V \leq V_{IN} \leq 5.25V$ $V_{IN} \geq 1.4V$		0.02	0.10	%/V		
RR	Ripple Rejection	$f = 1kHz$ Ripple 0.2Vp-p $V_{IN} = V_{SET} + 1.0V$ $I_{OUT} = 30mA$		75		dB		
V_{IN}	Input Voltage*1		1.4		5.25	V		
$\frac{\Delta V_{OUT}}{\Delta T_a}$	Output Voltage Temperature Coefficient	$-40^{\circ}C \leq T_a \leq 85^{\circ}C$	$V_{SET} \geq 1.8V$		± 30	ppm/ °C		
			$V_{SET} < 1.8V$		± 100			
I_{SC}	Short Current Limit	$V_{OUT} = 0V$		40		mA		
I_{PD}	CE Pull-down Current			0.3	0.6	μA		
V_{CEH}	CE Input Voltage "H"		1.0			V		
V_{CEL}	CE Input Voltage "L"				0.4	V		
en	Output Noise	BW = 10Hz to 100kHz	$V_{SET} \geq 1.8V$		20 x V_{SET}	μV_{rms}		
			$V_{SET} < 1.8V$		40 x V_{SET}			
R_{LOW}	Nch On Resistance for Auto-discharge (D Version Only)	$V_{IN} = 4.0V$ $V_{CE} = 0V$		60		Ω		

All test items listed under *Electrical Characteristics* are done under the pulse load condition ($T_j \approx T_a = 25^{\circ}C$) except Output Noise, Ripple Rejection, and Output Voltage Temperature Coefficient.

*1 Maximum input voltage is 5.25V. If, for any reason the input voltage exceeds 5.25V, it has to be no more than 5.5V, and total operating time should be within 500 hours.

The specifications surrounded by are guaranteed by Design Engineering at $-40^{\circ}\text{C} \leq T_a \leq 85^{\circ}\text{C}$.

Dropout Voltage

(Ta=25°C)

Set Output Voltage V_{SET} (V)	Dropout Voltage V_{DIF} (V)		
	Condition	Typ.	Max.
$V_{\text{SET}} = 0.8$	$I_{\text{OUT}} = 150\text{mA}$	0.70	1.00
$V_{\text{SET}} = 0.85$		0.70	1.00
$V_{\text{SET}} = 0.9$		0.62	0.91
$1.0 \leq V_{\text{SET}} < 1.2$		0.56	0.82
$1.2 \leq V_{\text{SET}} < 1.4$		0.47	0.67
$1.4 \leq V_{\text{SET}} < 1.8$		0.39	0.54
$1.8 \leq V_{\text{SET}} < 2.1$		0.33	0.48
$2.1 \leq V_{\text{SET}} < 2.5$		0.28	0.40
$2.5 \leq V_{\text{SET}} < 3.0$		0.25	0.35
$3.0 \leq V_{\text{SET}} \leq 3.6$		0.23	0.32

RECOMMENDED OPERATING CONDITIONS (ELECTRICAL CHARACTERISTICS)

All of electronic equipment should be designed that the mounted semiconductor devices operate within the recommended operating conditions. The semiconductor devices cannot operate normally over the recommended operating conditions, even if when they are used over such conditions by momentary electronic noise or surge. And the semiconductor devices may receive serious damage when they continue to operate over the recommended operating conditions.

TYPICAL APPLICATION

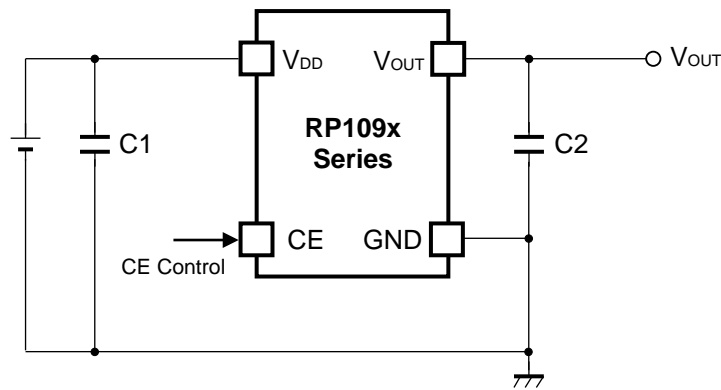

(External Components)

C2 0.1 μ F MURATA: GRM155B31C104KA87B

TECHNICAL NOTES

When using these ICs, consider the following points:

Phase Compensation

In these ICs, phase compensation is made for securing stable operation even if the load current is varied. For this purpose, use a capacitor C2 with 0.1 μ F or more and good ESR (Equivalent Series Resistance).

(Note: If additional ceramic capacitors are connected with parallel to the output pin with an output capacitor for phase compensation, the operation might be unstable. Because of this, test these ICs with as same external components as ones to be used on the PCB.)

PCB Layout

Make V_{DD} and GND lines sufficient. If their impedance is high, noise pickup or unstable operation may result. Connect a capacitor C1 with a capacitance value as much as 0.1 μ F or more between V_{DD} and GND pin, and as close as possible to the pins.

Set external components, especially the output capacitor C2, as close as possible to the ICs, and make wiring as short as possible.

TEST CIRCUITS

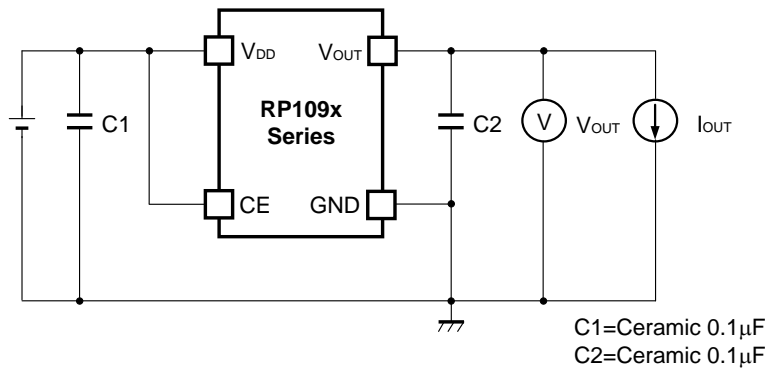

Basic Test Circuit

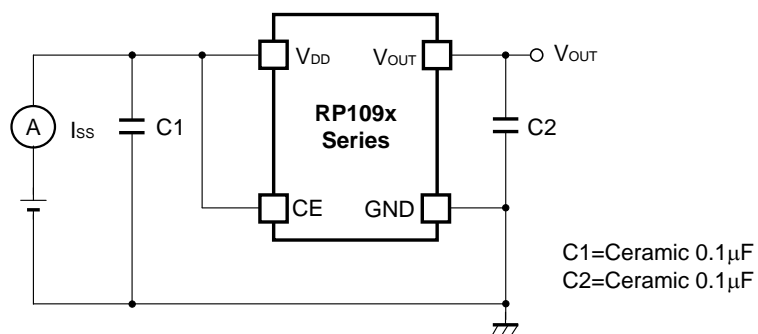

Test Circuit for Supply Current

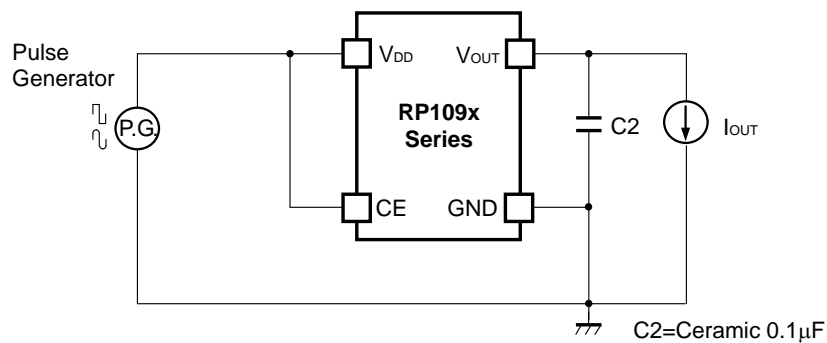

Test Circuit for Ripple Rejection

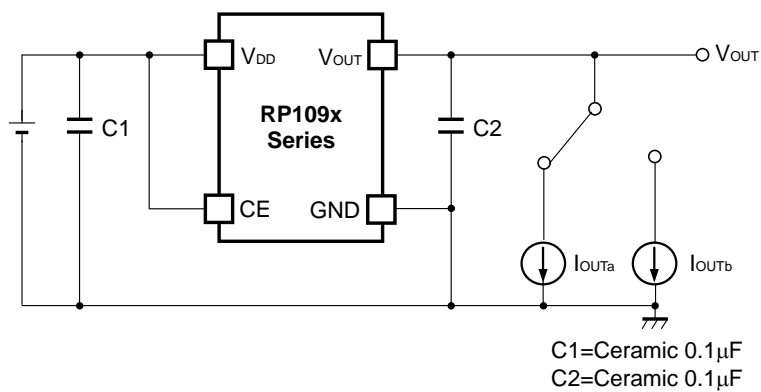

Test Circuit for Load Transient Response

TYPICAL CHARACTERISTICS

1) Output Voltage vs. Output Current (C1=0.1μF, C2=0.1μF, T_{opt}=25°C)

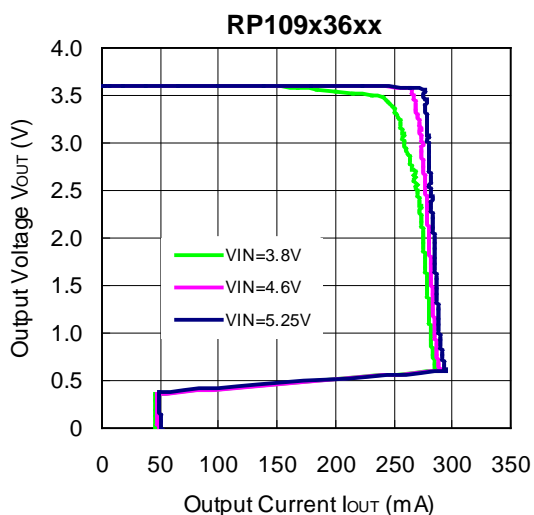
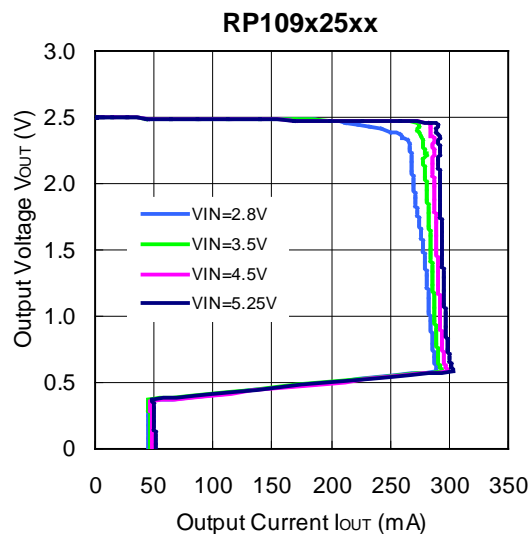
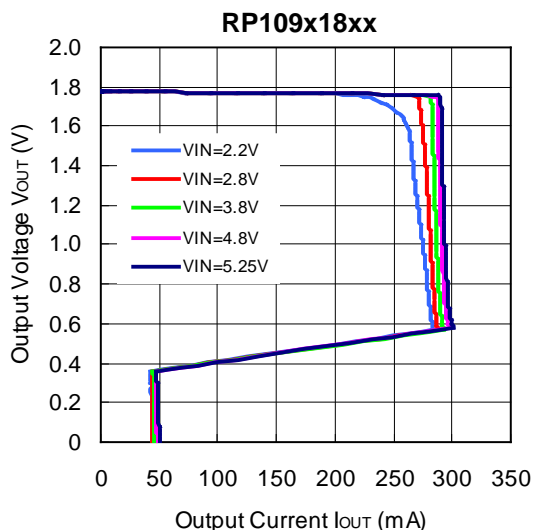
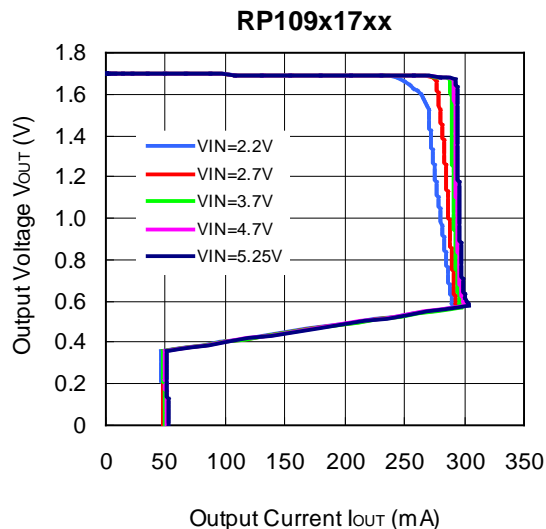
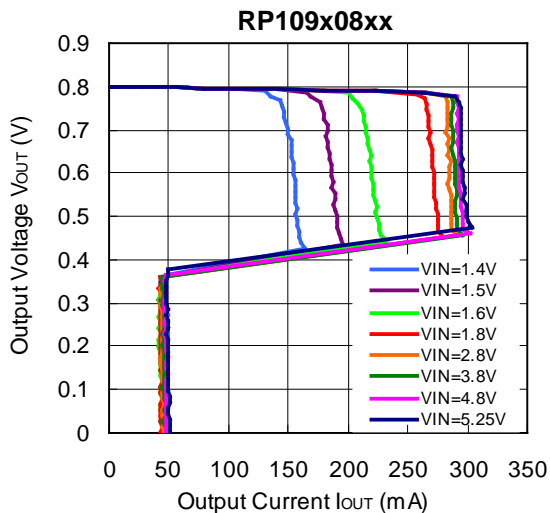

2) Output Voltage vs. Input Voltage (C1=0.1μF, C2=0.1μF, T_{opt}=25°C)

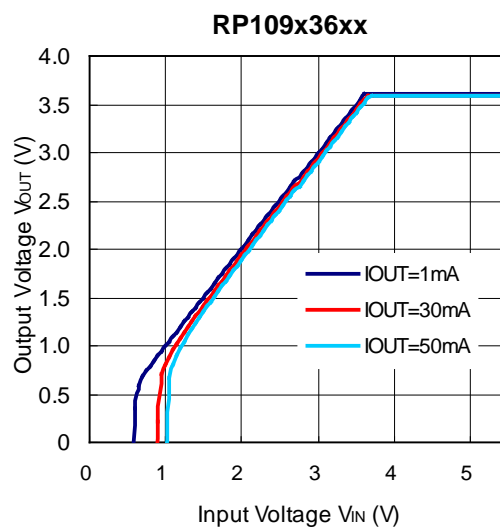
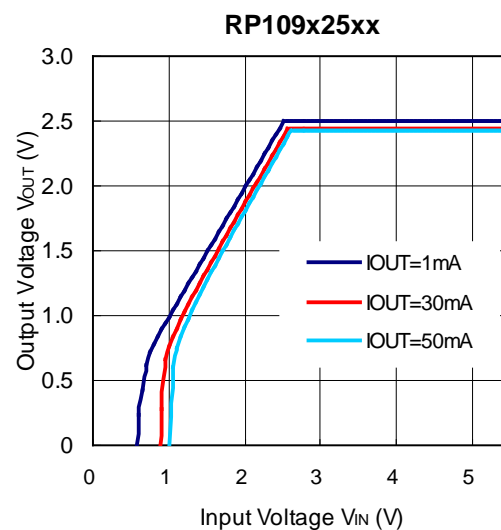
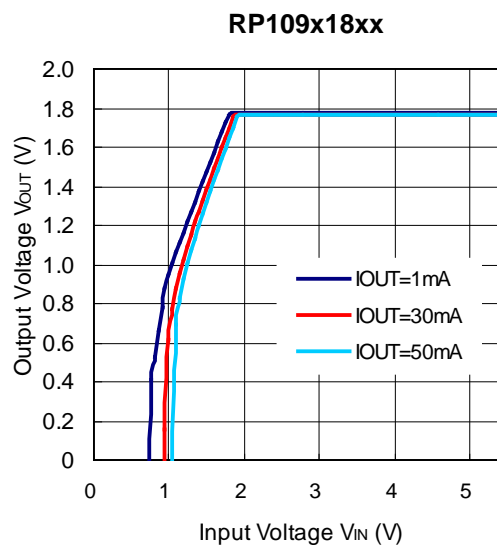
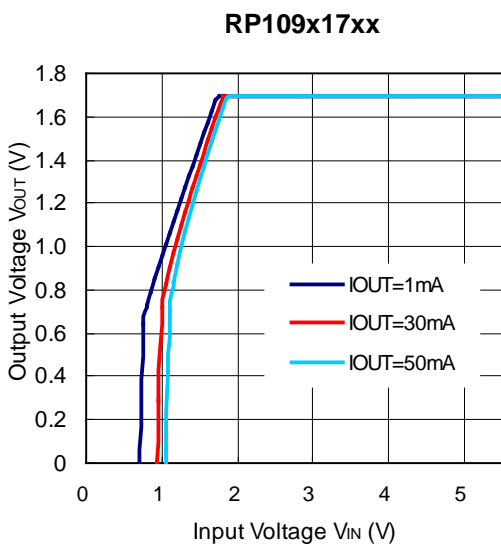
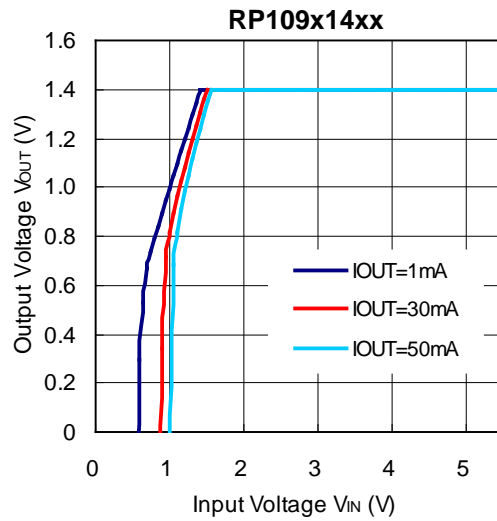
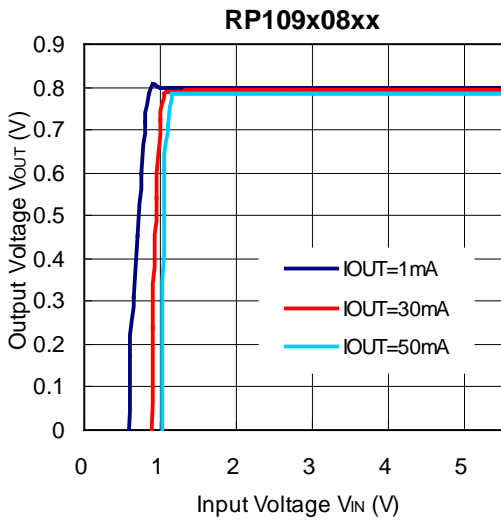

3) Supply Current vs. Input Voltage (C1=0.1μF, C2=0.1μF, T_{opt}=25°C)

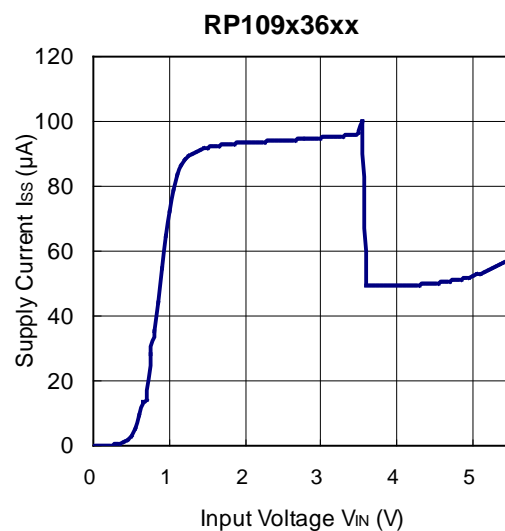
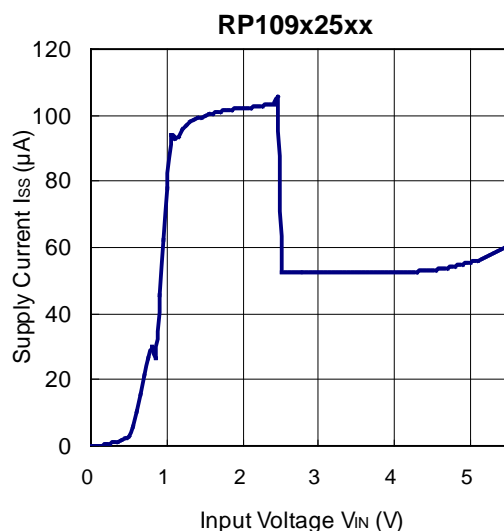
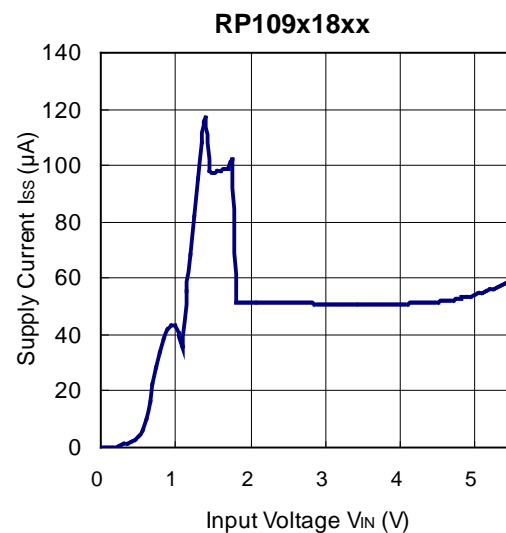
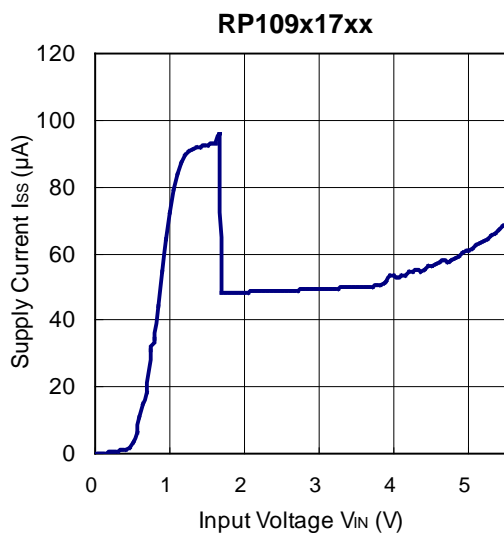
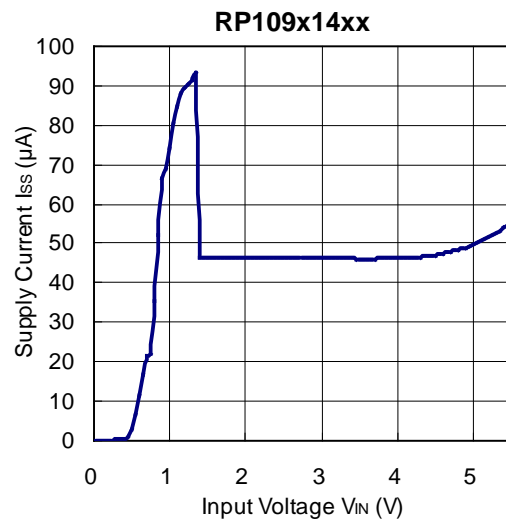
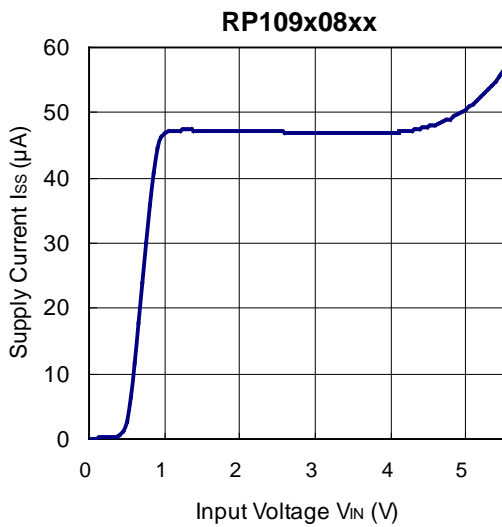

4) Output Voltage vs. Temperature (C1=0.1μF, C2=0.1μF, I_{OUT}=1mA)

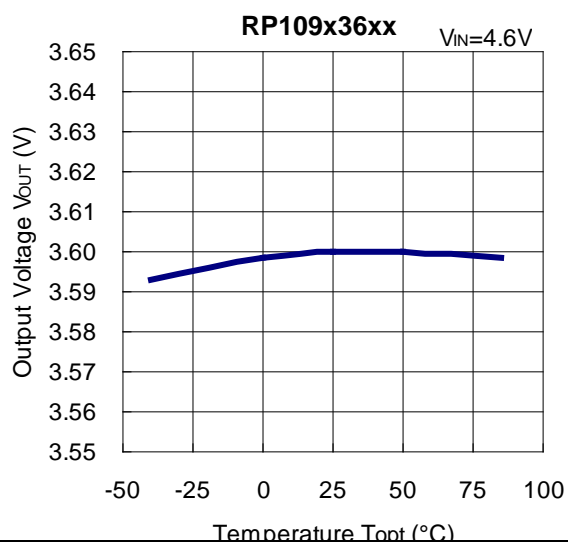
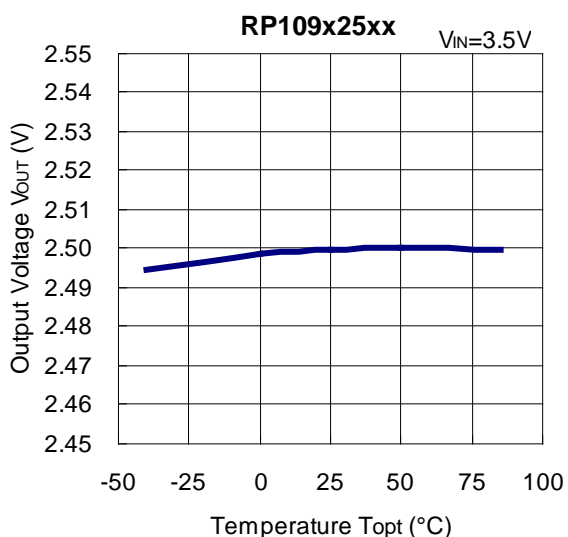
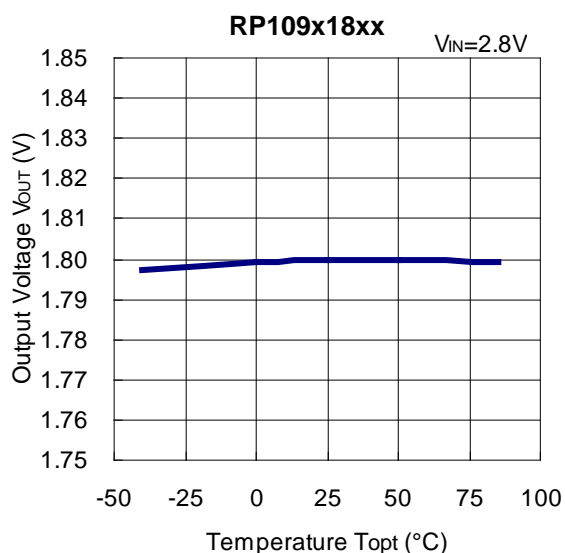
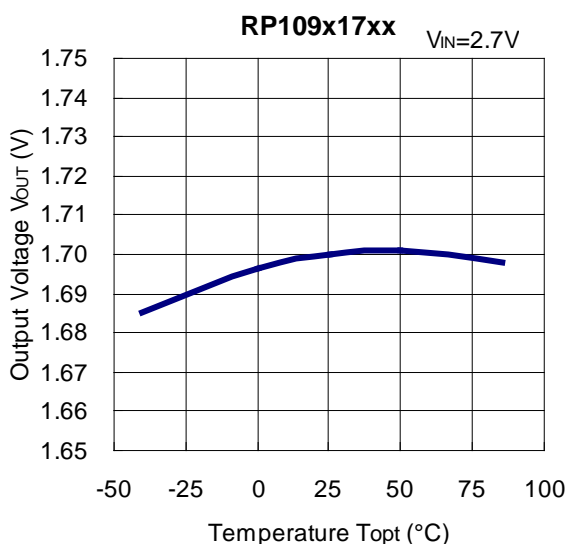
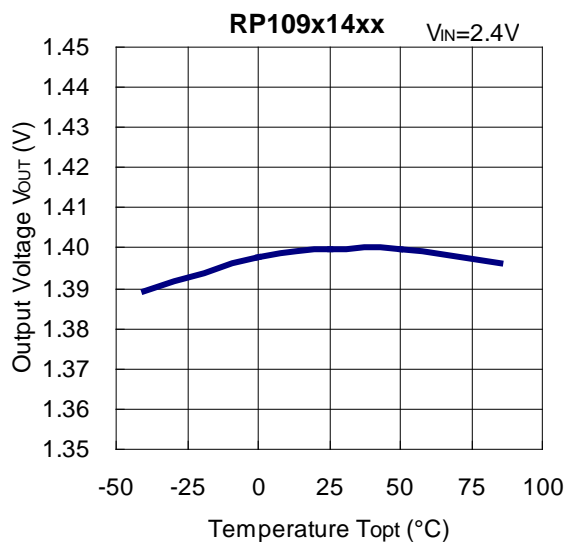
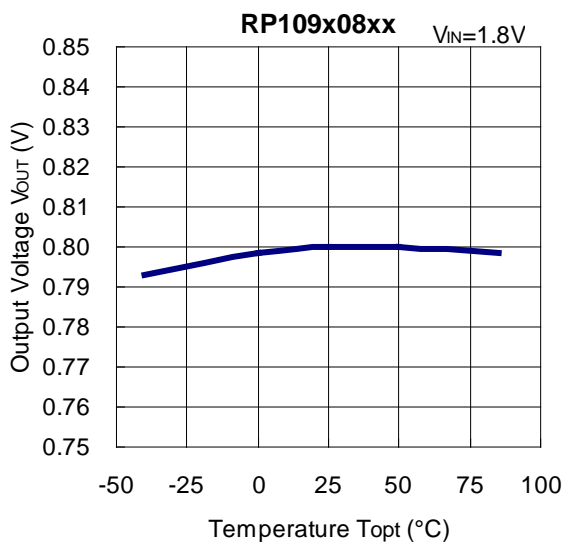

5) Supply Current vs. Temperature (C1=0.1μF, C2=0.1μF, I_{OUT}=0mA)

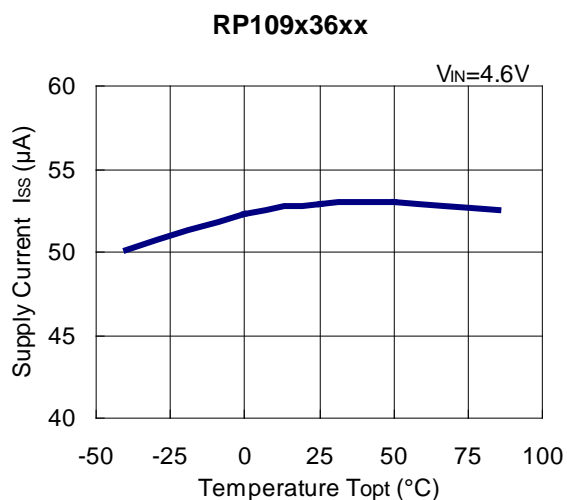
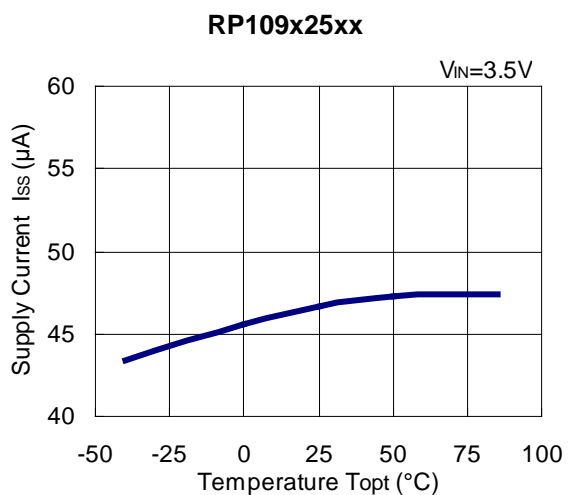
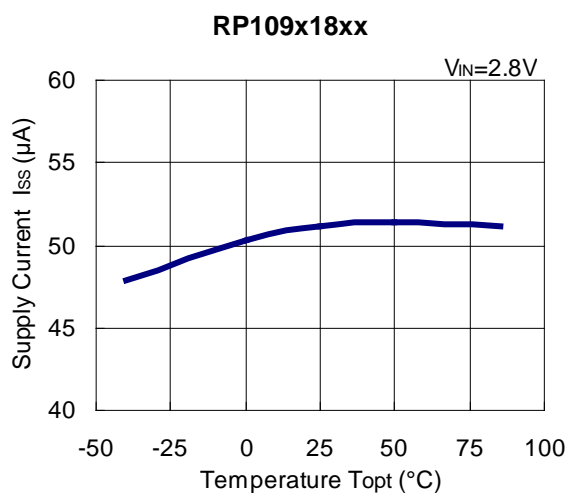
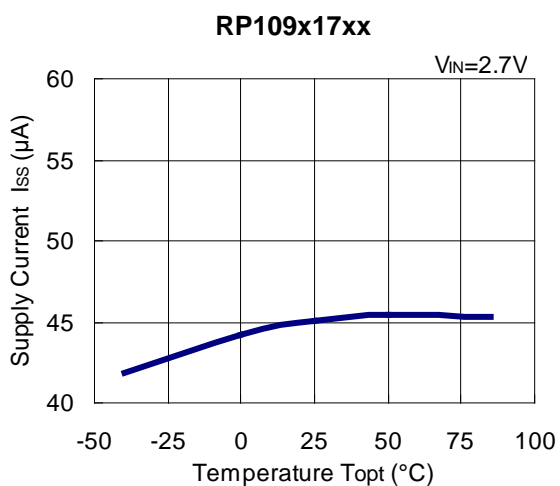
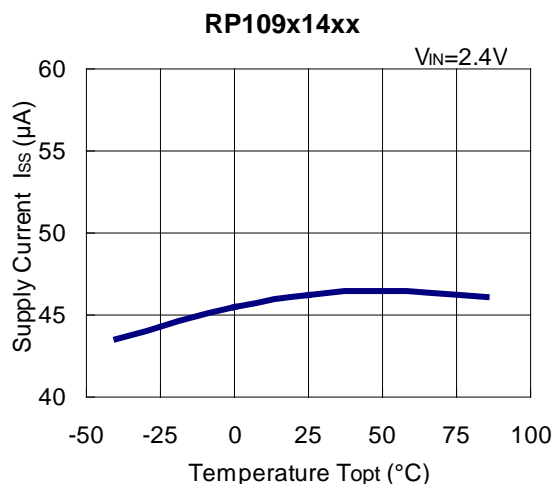
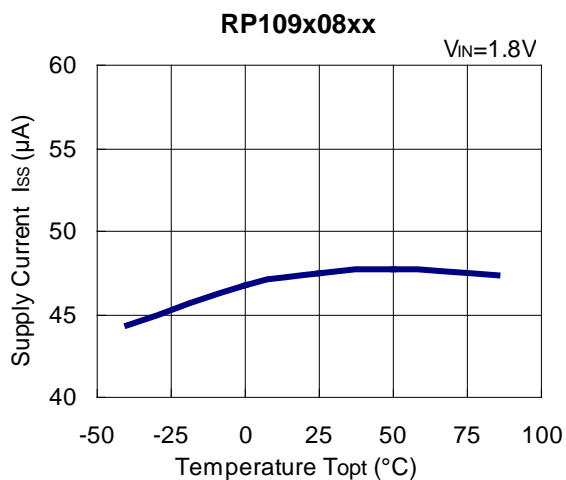

6) Dropout Voltage vs. Output Current (C1=0.1μF, C2=0.1μF)

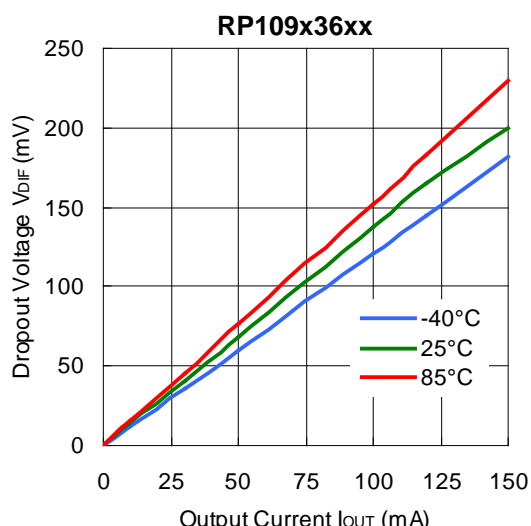
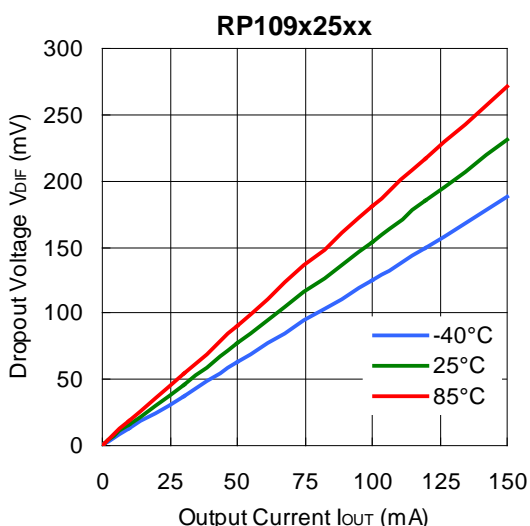
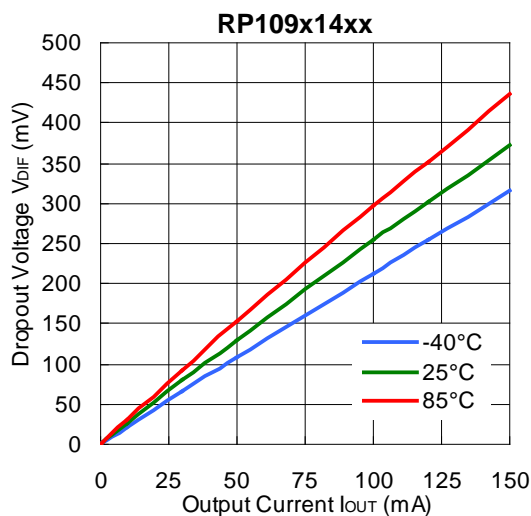
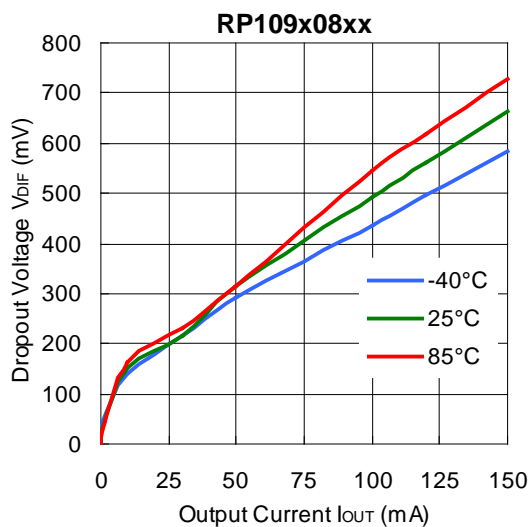

7) Dropout Voltage vs. Set Output Voltage (C1=0.1μF, C2=0.1μF, T_{opt}=25°C)

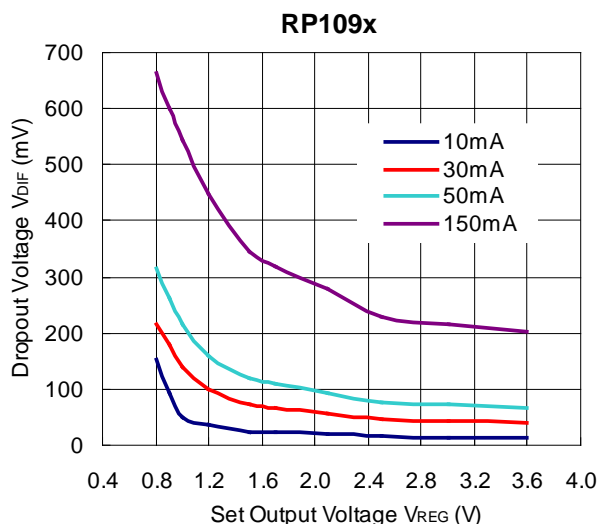

8) Ripple Rejection vs. Input Bias Voltage (C1=none, C2=0.1μF, Ripple=0.2Vp-p, T_{opt}=25°C)

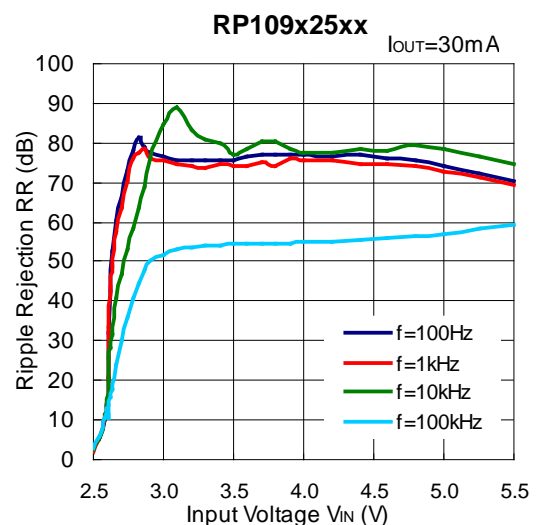
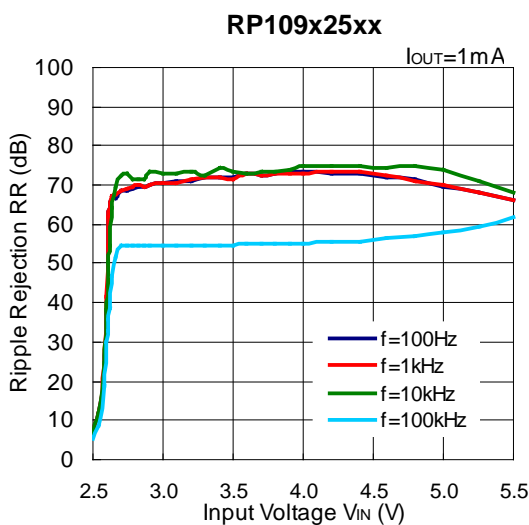
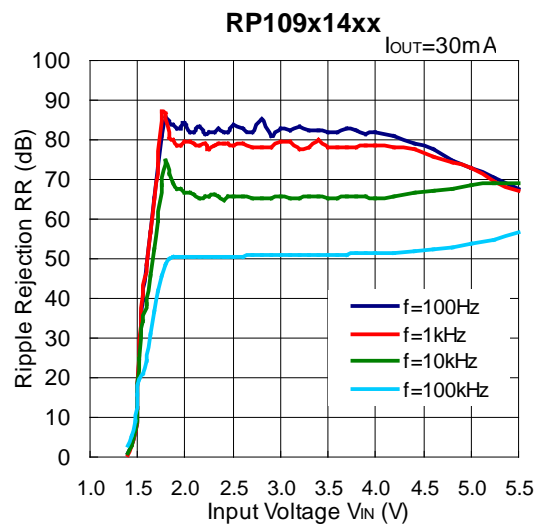
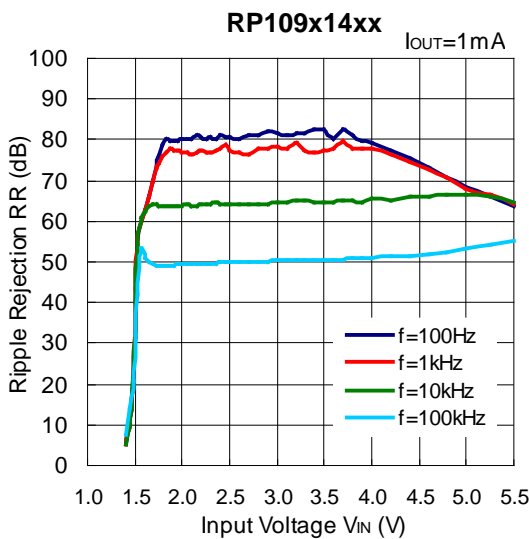
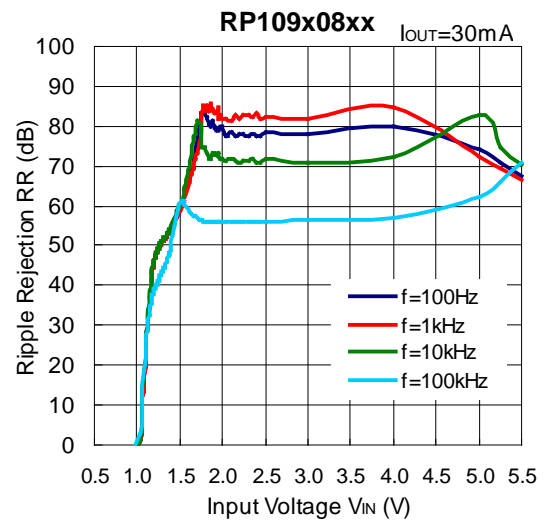
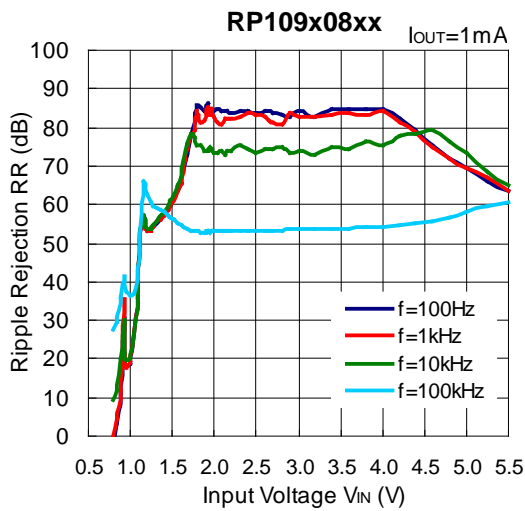

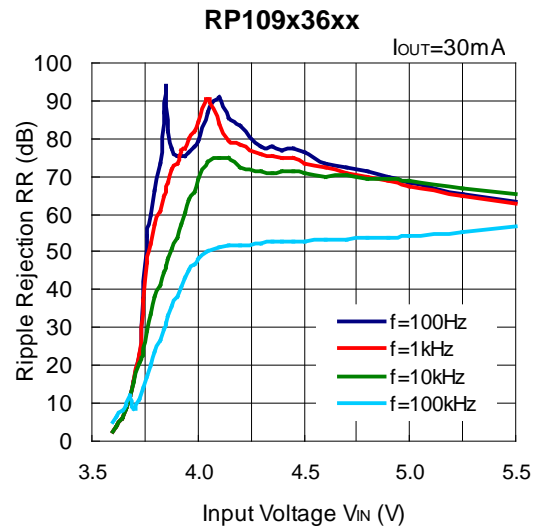
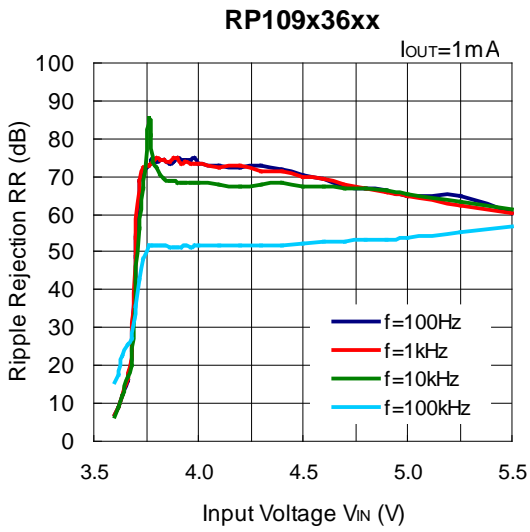

9) Ripple Rejection vs. Frequency (C1=none, C2=0.1 μ F, Ripple=0.2Vp-p)

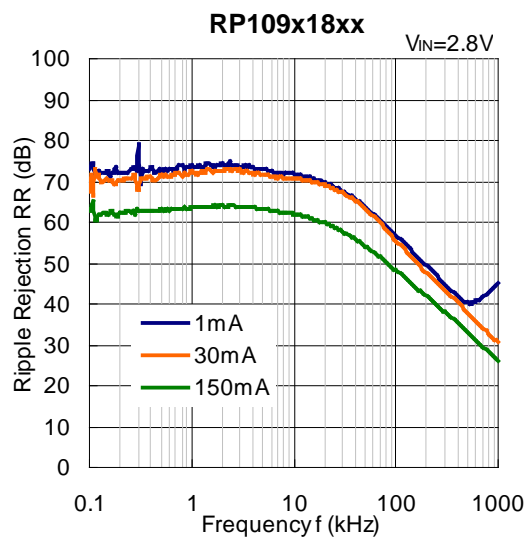
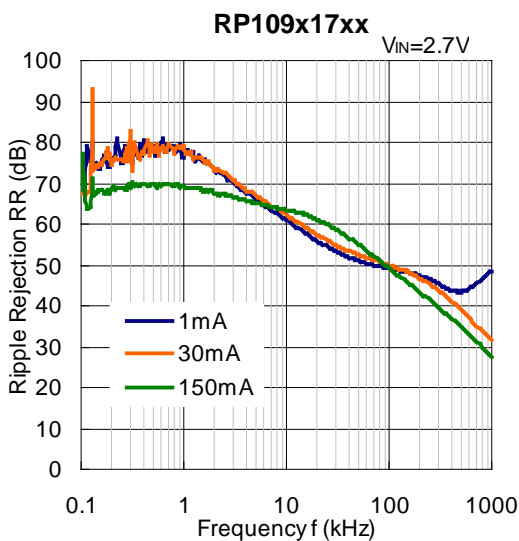
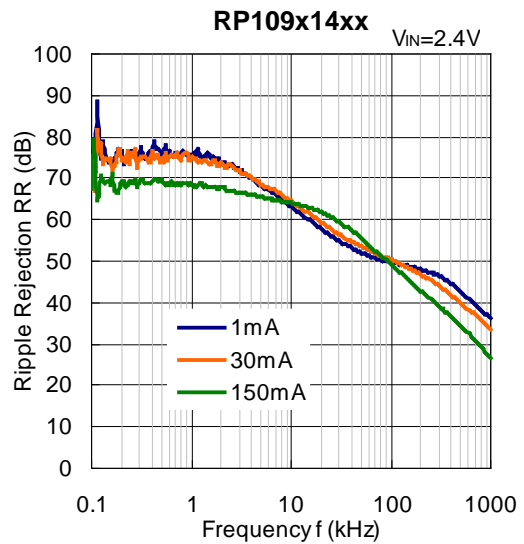
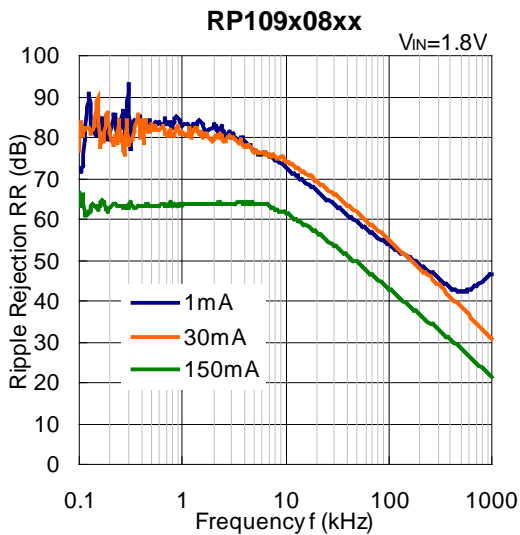

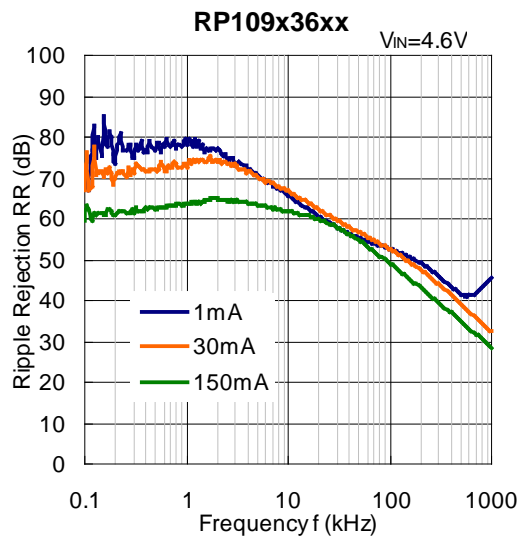
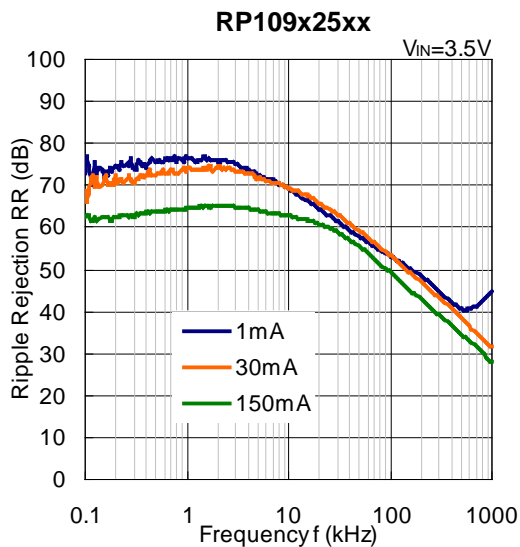

10) Input Transient Response ($C1=none$, $C2=0.1\mu F$, $I_{OUT}=30mA$, $t_r=t_f=5\mu s$, $T_{opt}=25^\circ C$)

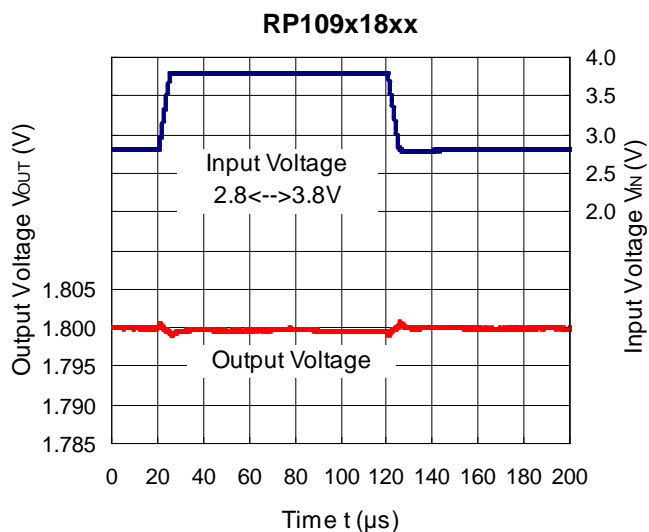
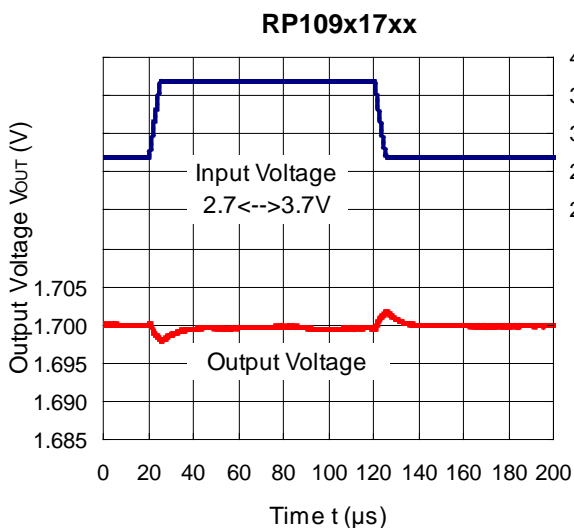
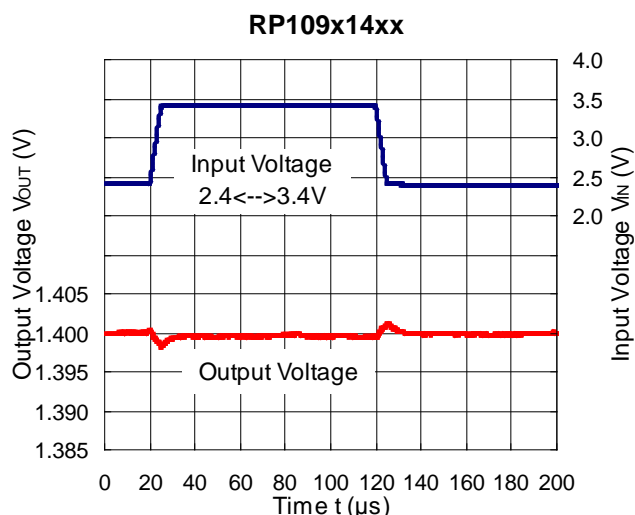
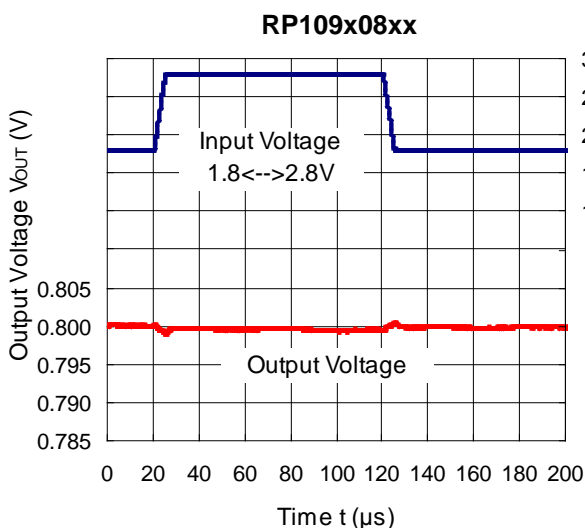

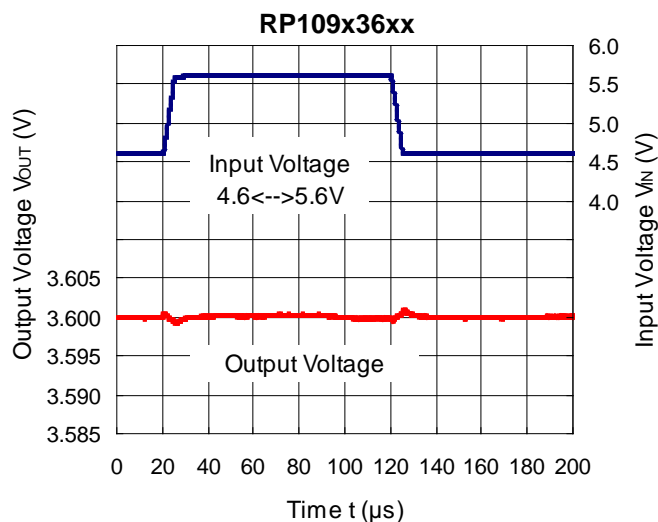
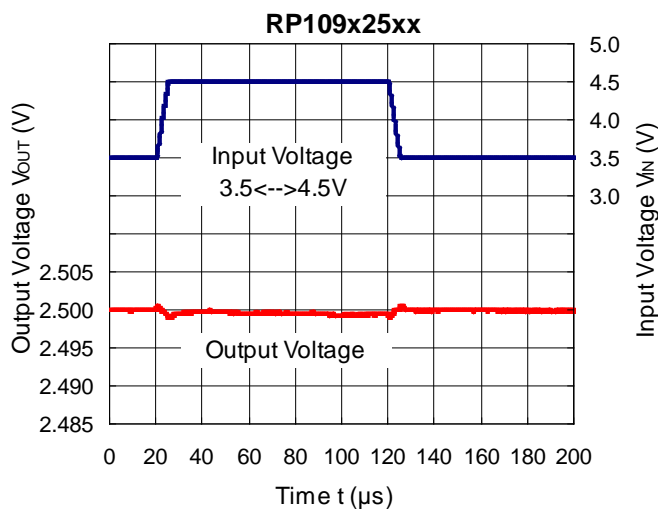

11) Load Transient Response ($C_1=0.1\mu\text{F}$, $C_2=0.1\mu\text{F}$, $t_r=t_f=5\mu\text{s}$, $T_{opt}=25^\circ\text{C}$)

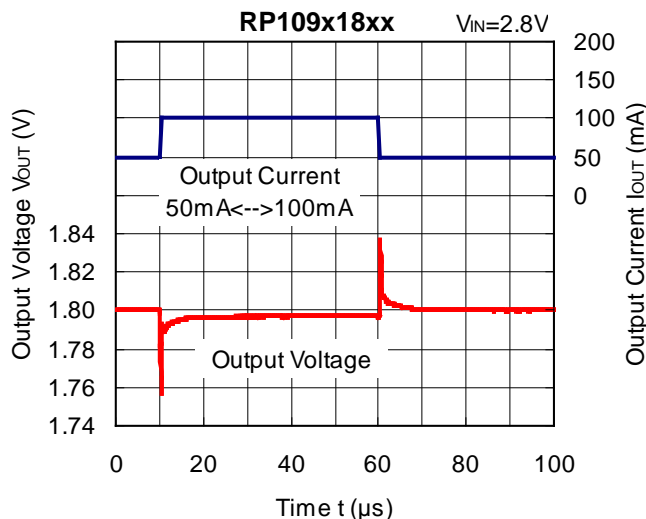
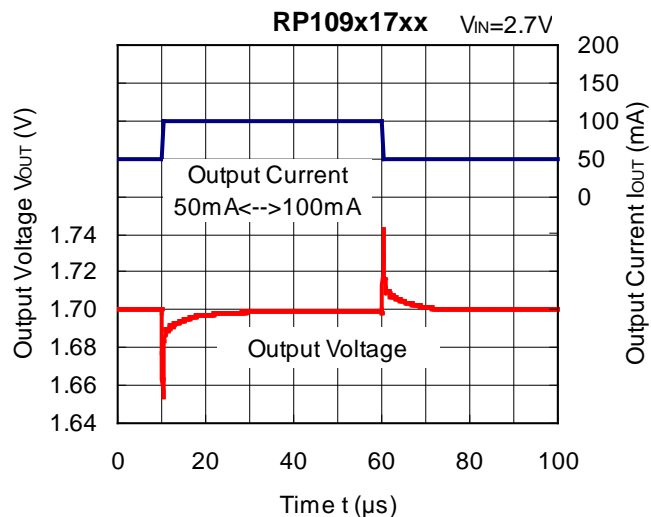
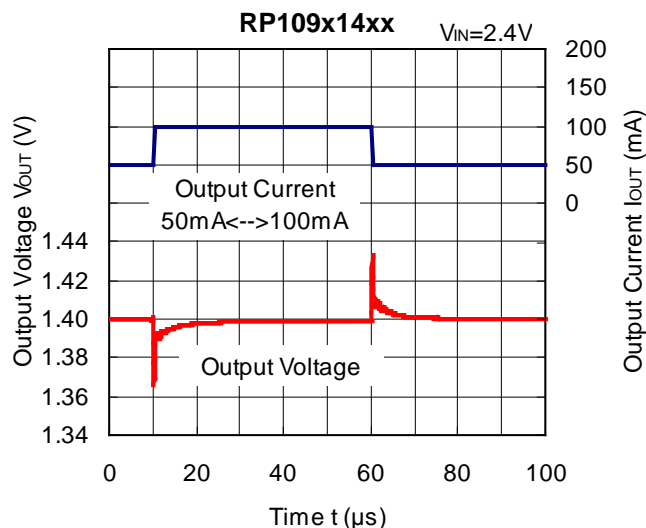
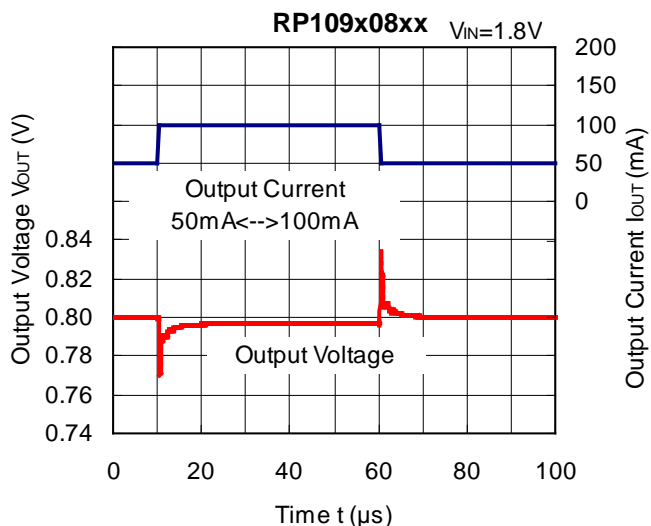

RP109x

NO.EA-204-240515

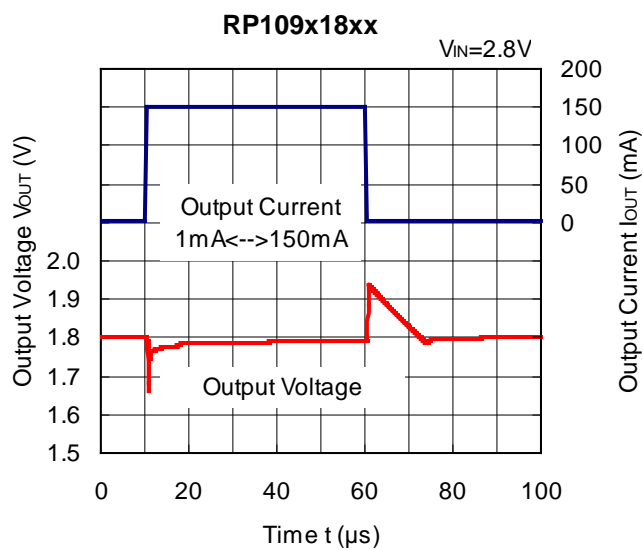
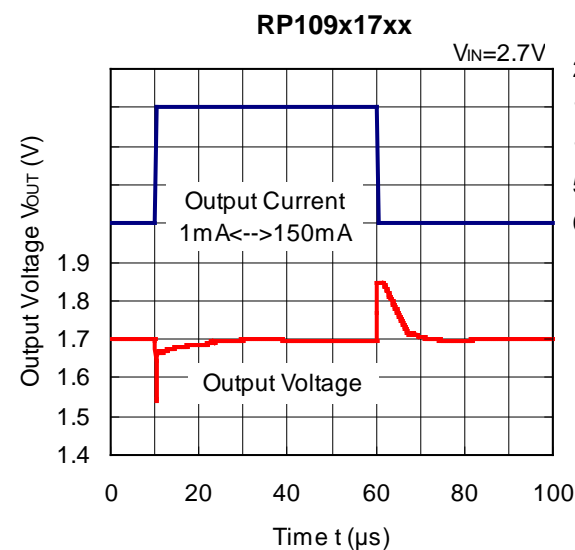
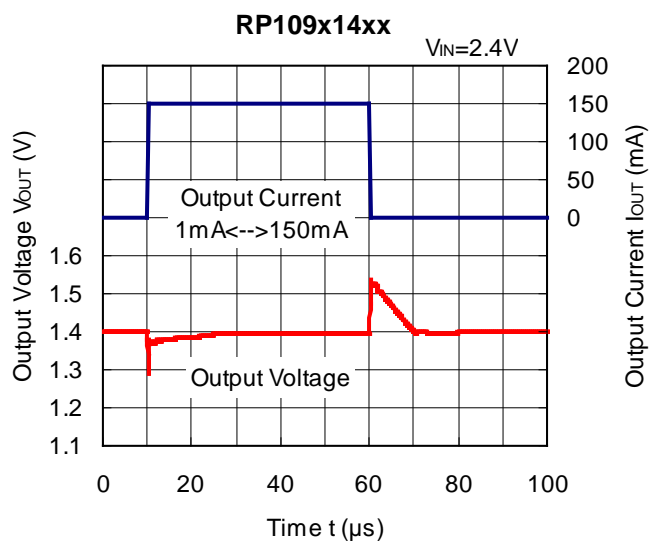
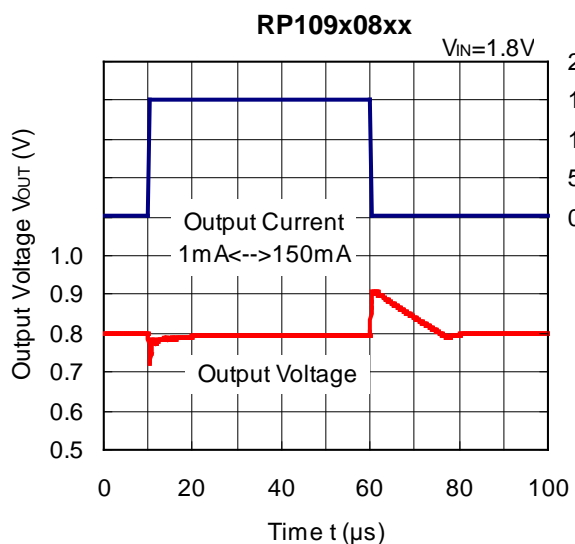
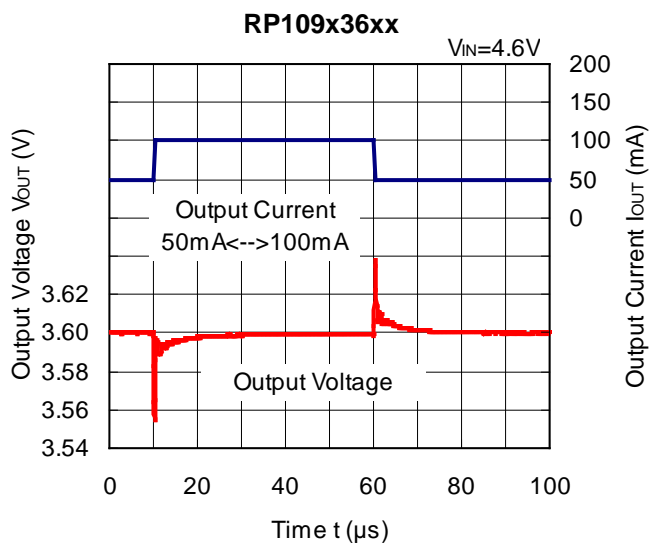
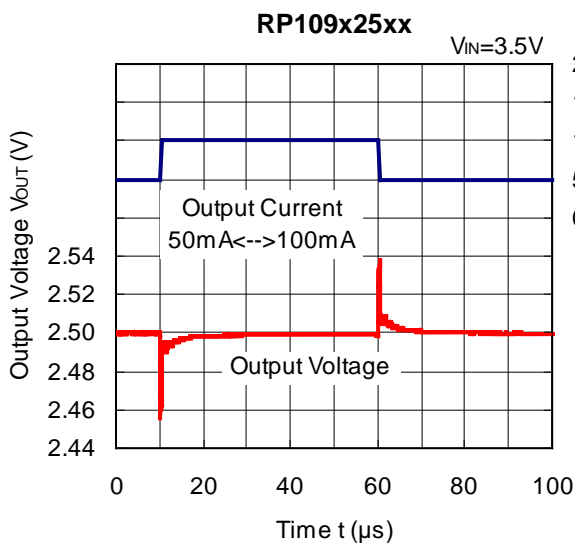

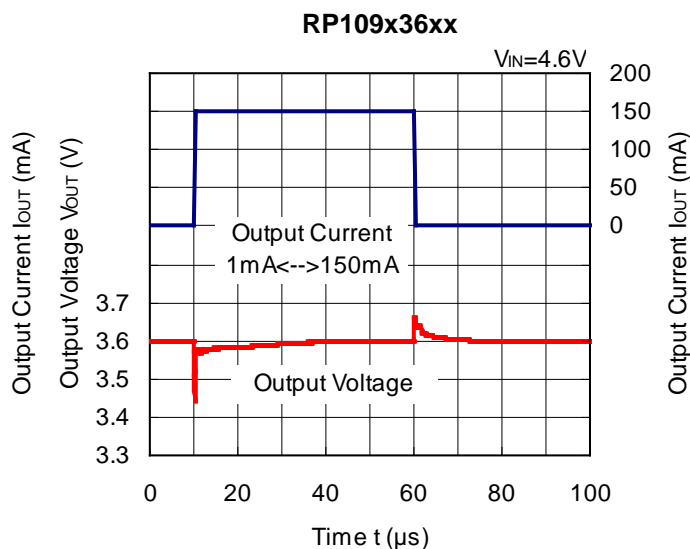
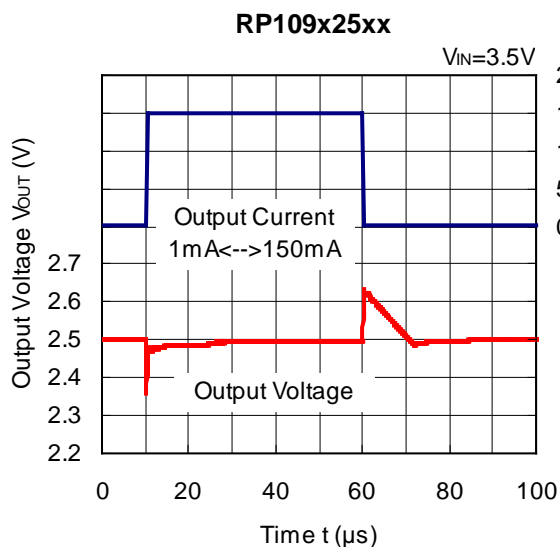

12) Turn On Speed with CE pin ($C1=0.1\mu F$, $C2=0.1\mu F$, $T_{opt}=25^{\circ}C$)

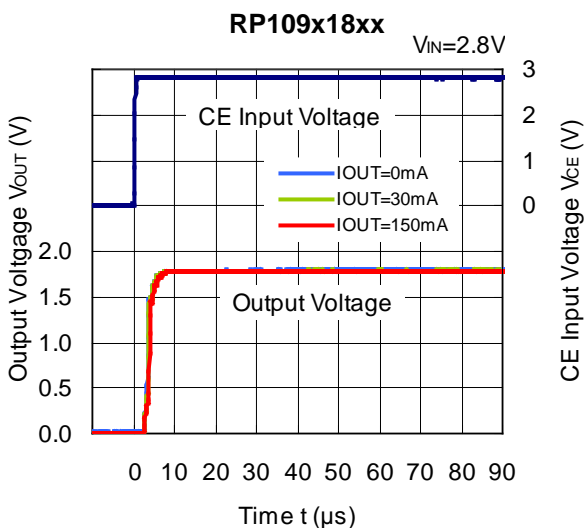
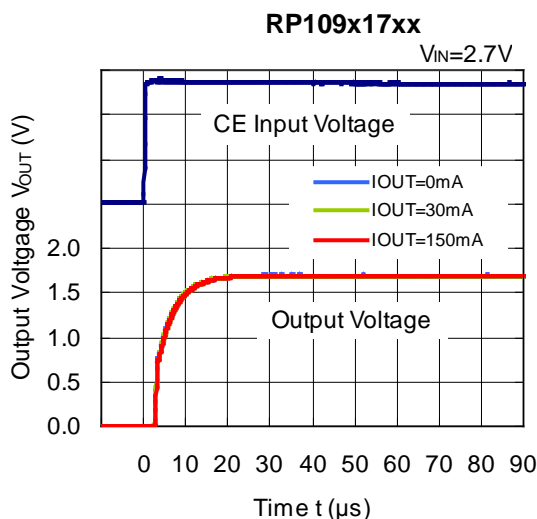
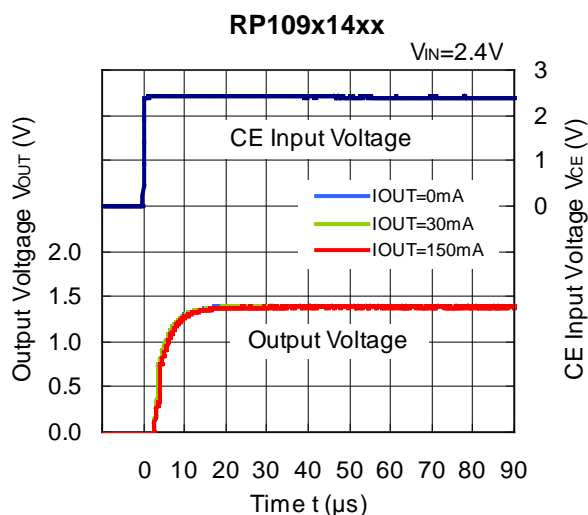
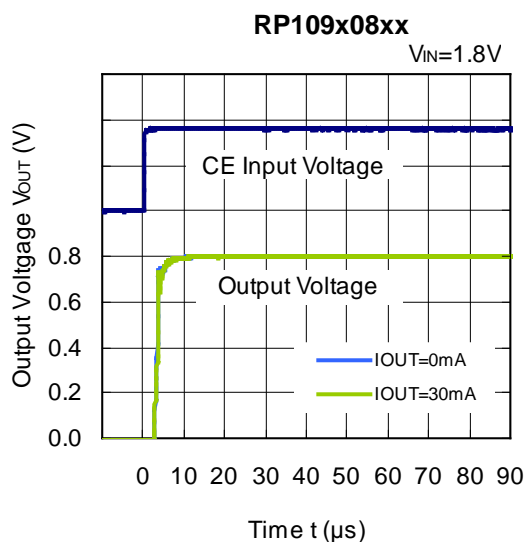

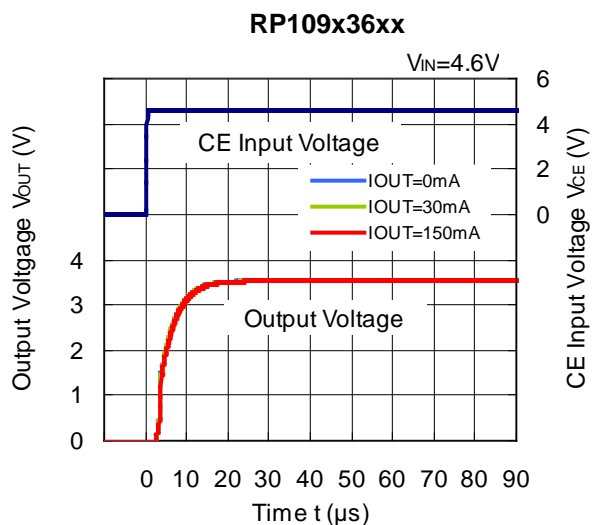
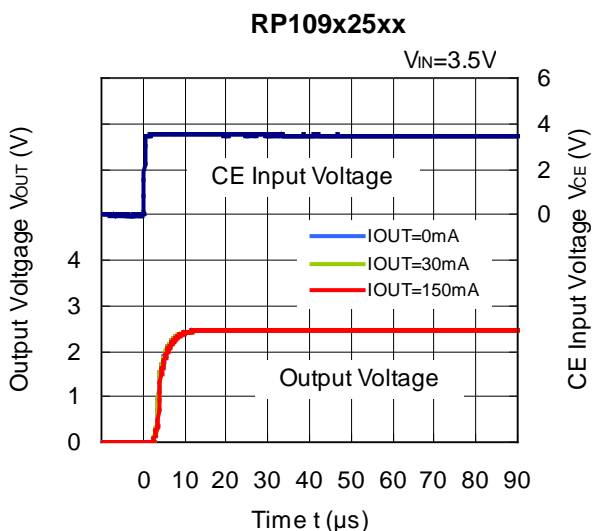

13) Turn Off Speed with CE pin (B Version) (C1=0.1 μ F, C2=0.1 μ F, T_{opt}=25°C)

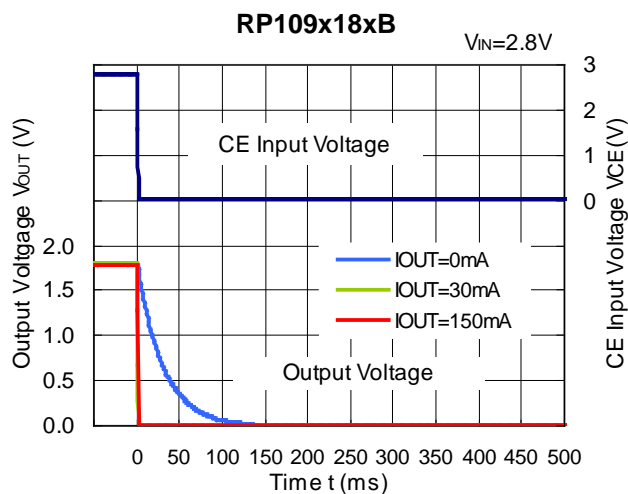
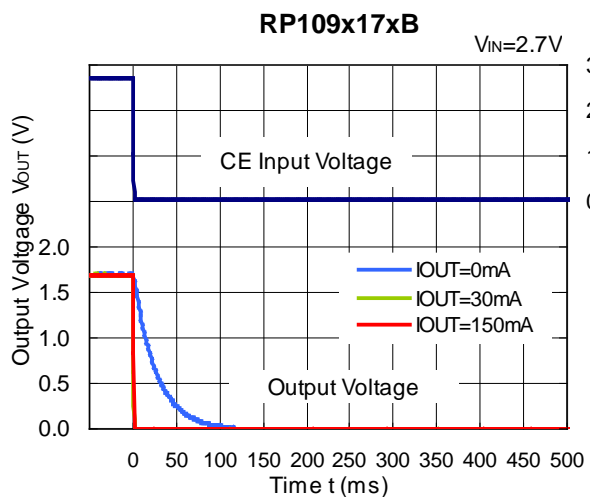
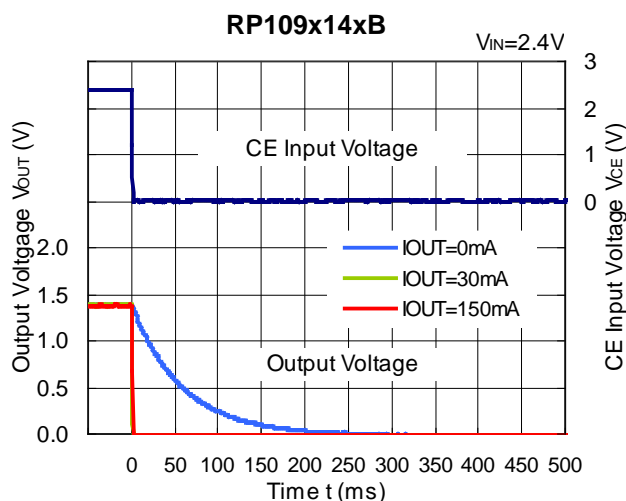
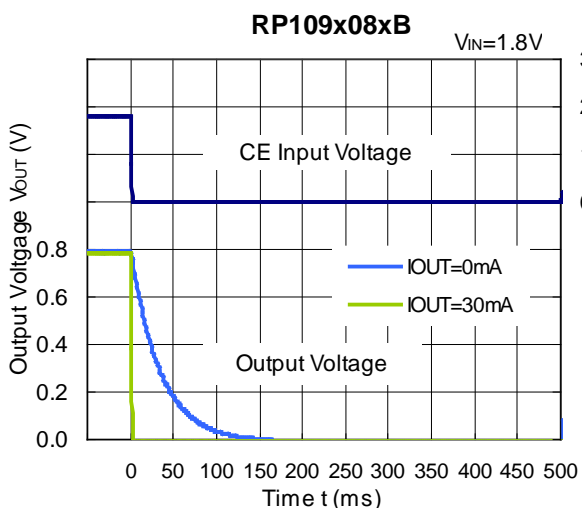

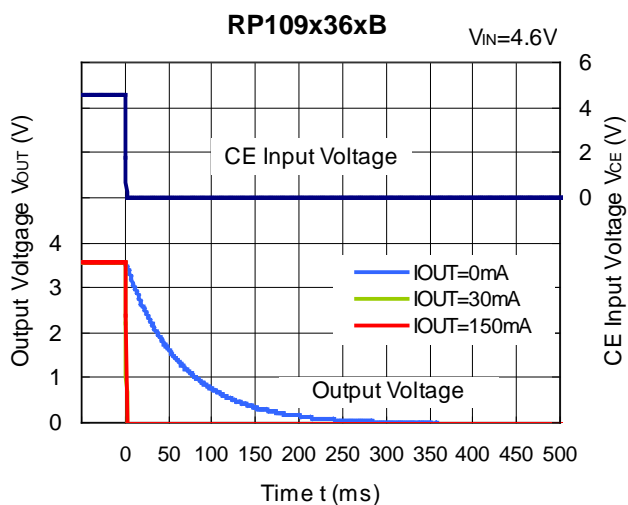
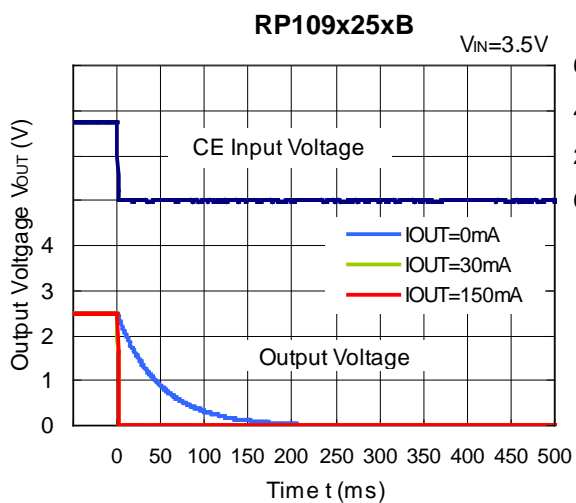

14) Turn Off Speed with CE pin (D Version) (C1=0.1 μ F, C2=0.1 μ F, T_{opt}=25°C)

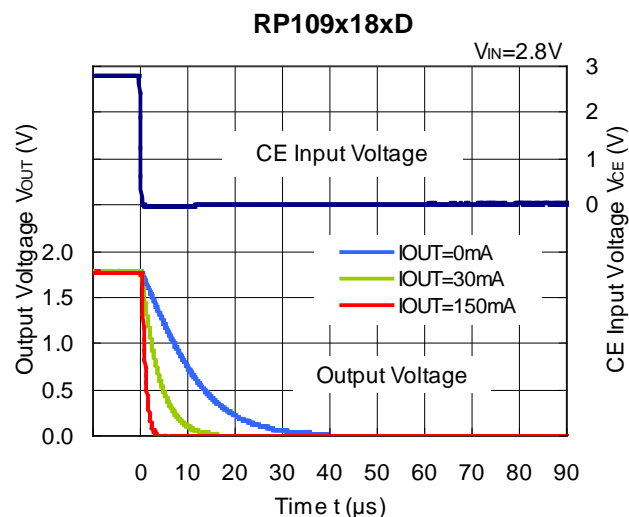
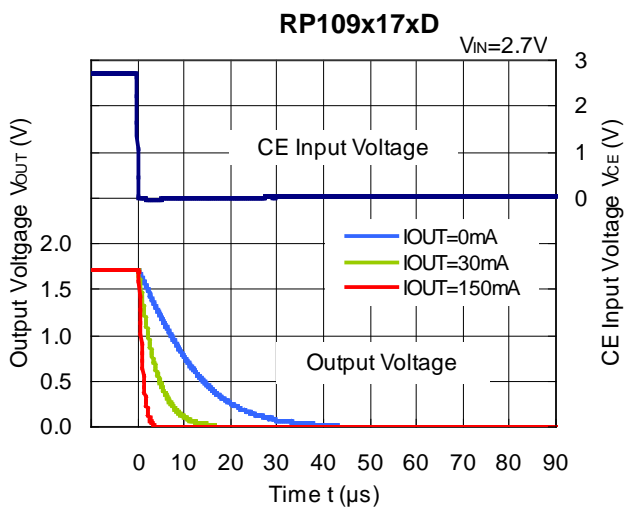
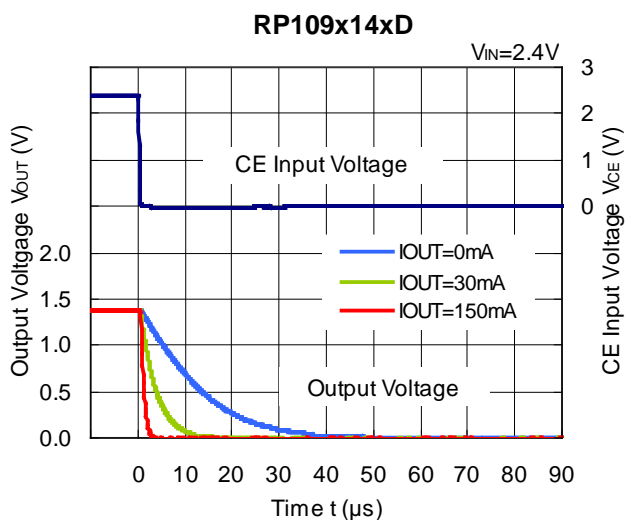
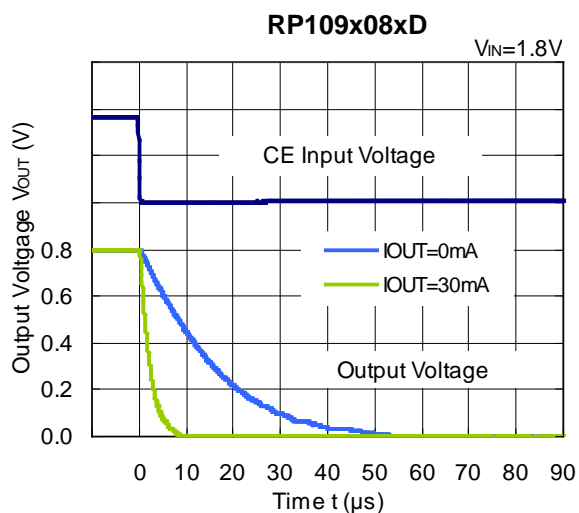

RP109x25xD

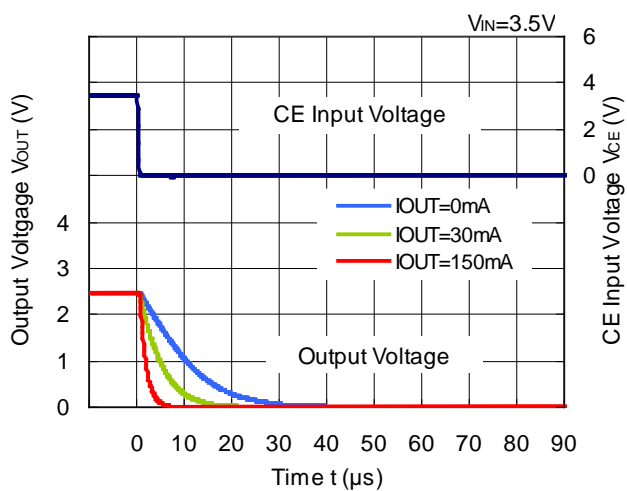

RP109x36xD

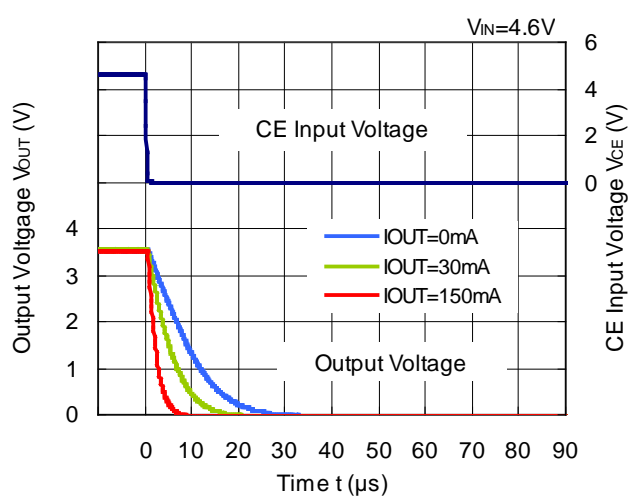

15) Inrush Current ($C_1=4.7\mu\text{F}$, $I_{OUT}=0\text{mA}$, $T_{opt}=25^\circ\text{C}$)

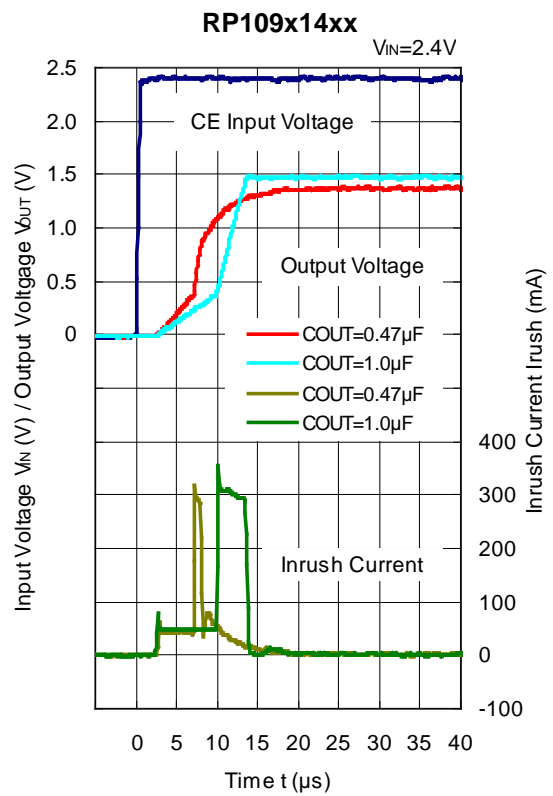
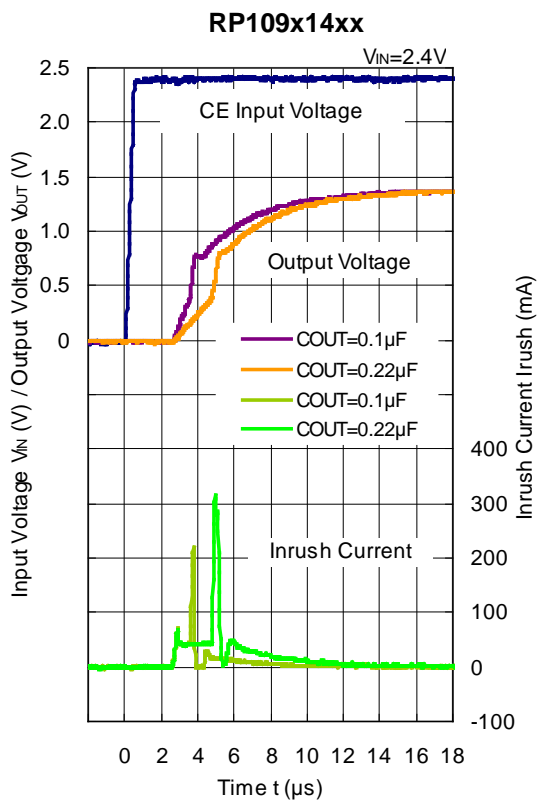
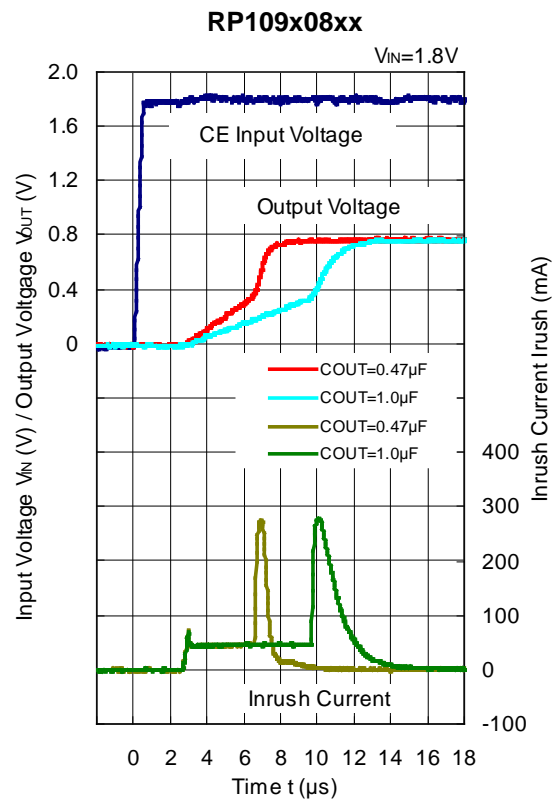
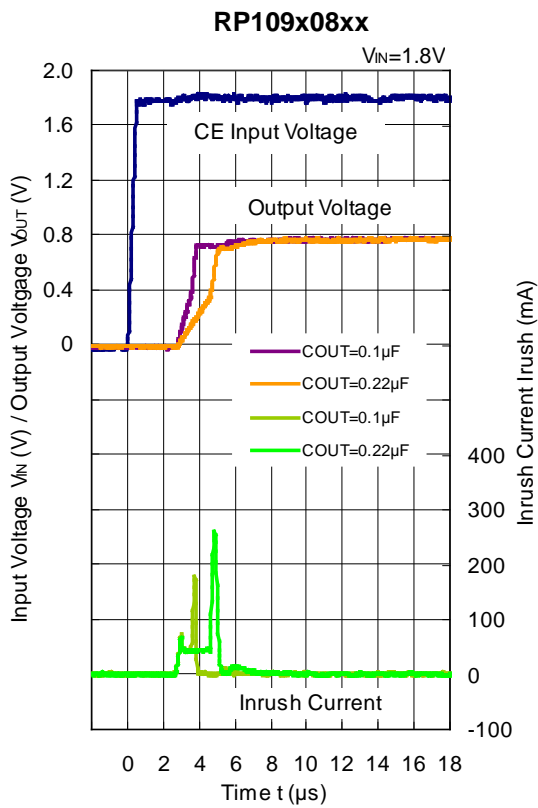

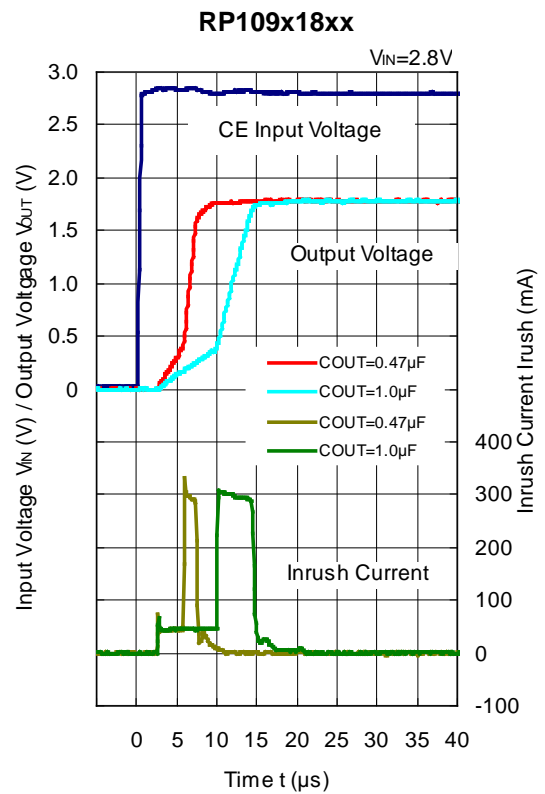
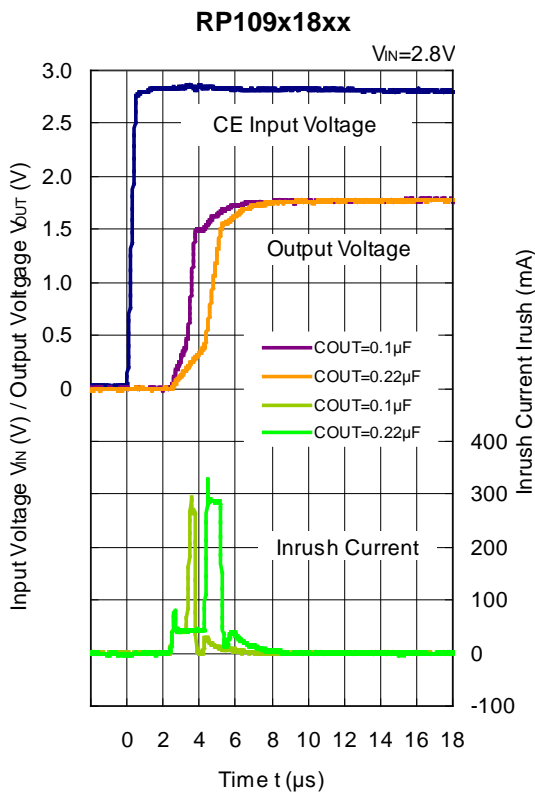
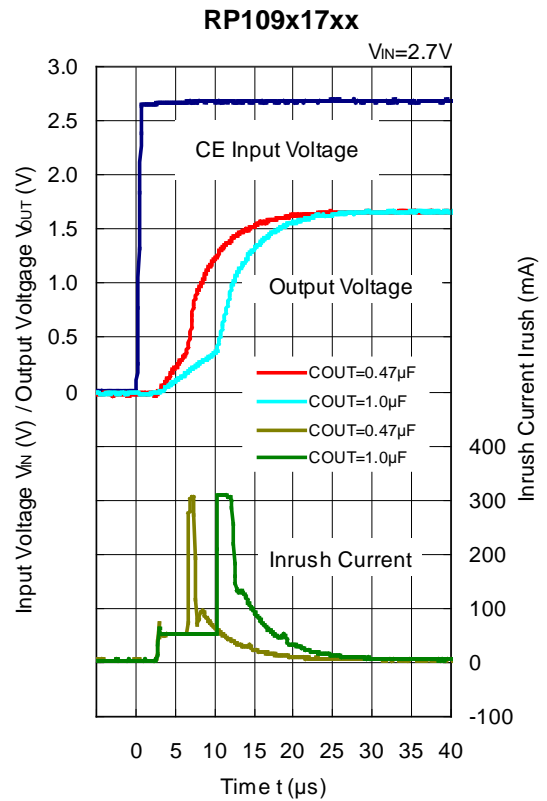
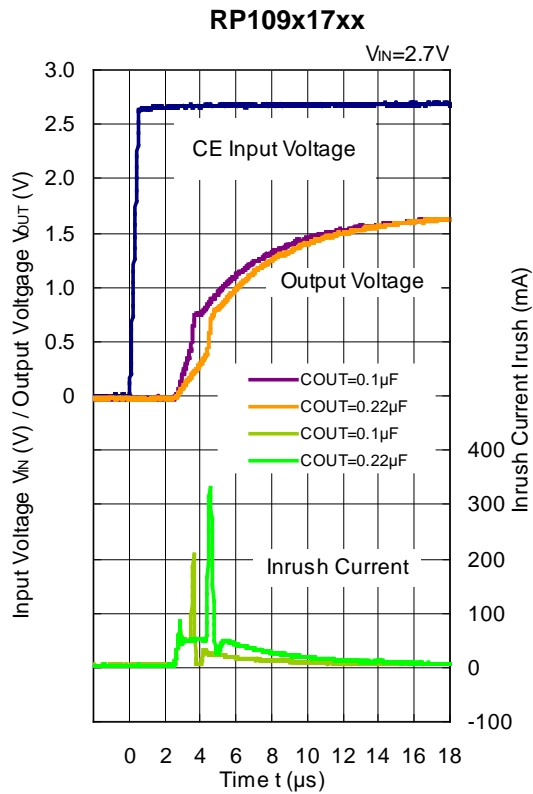

RP109x25xx

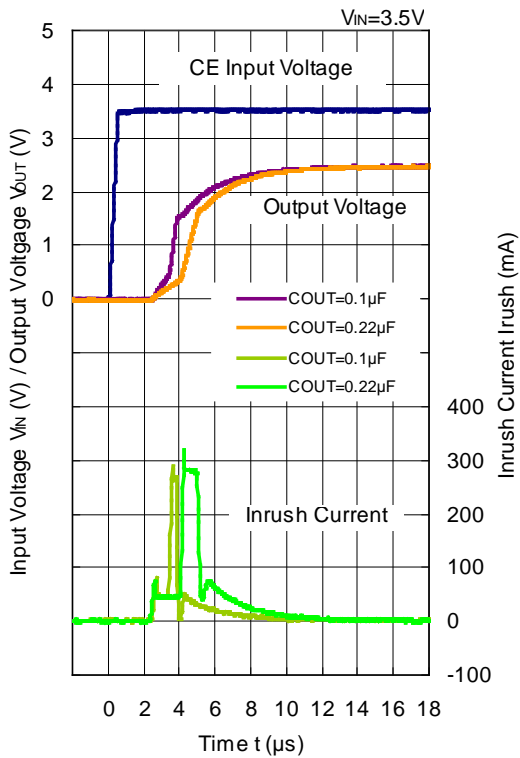

RP109x25xx

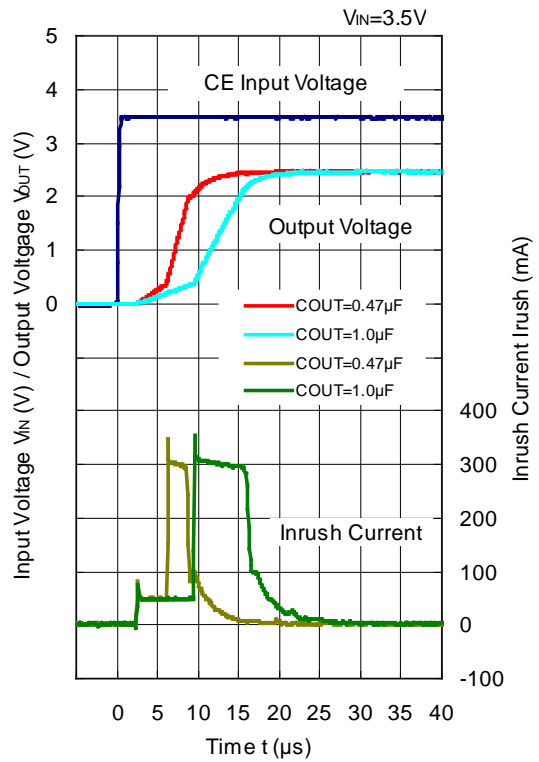

RP109x36xx

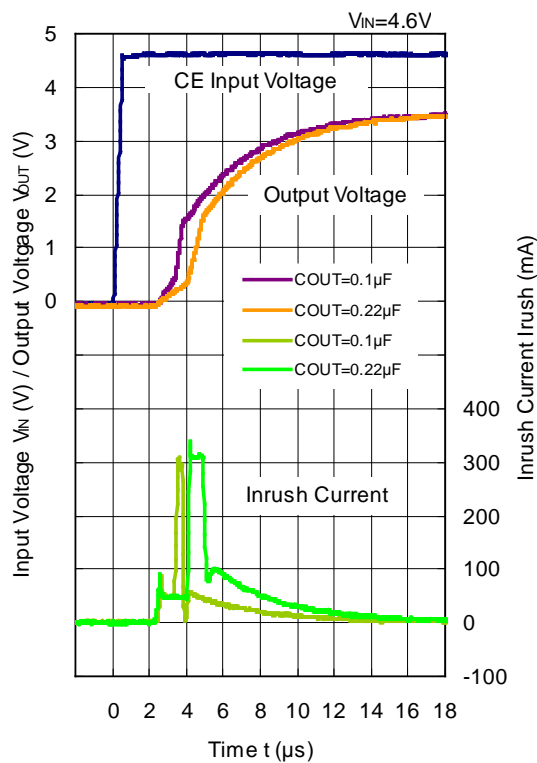

RP109x36xx

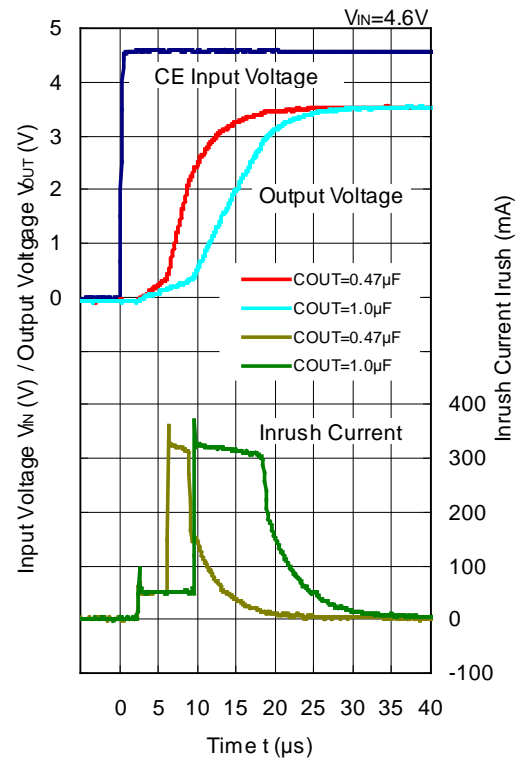

16) Dropout Voltage vs. Temperature (C1=0.1μF, C2=0.1μF)

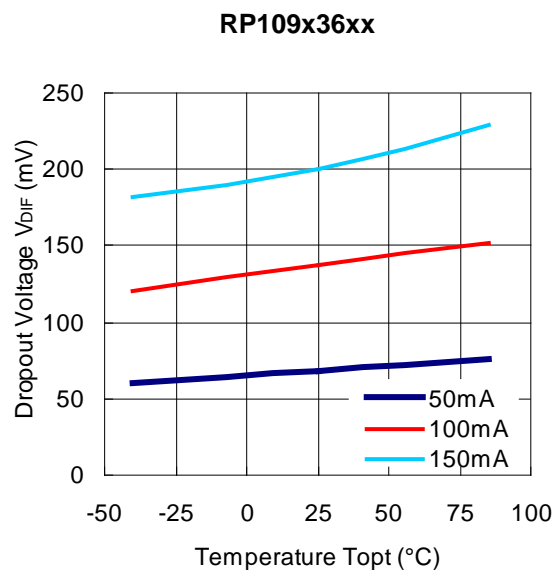
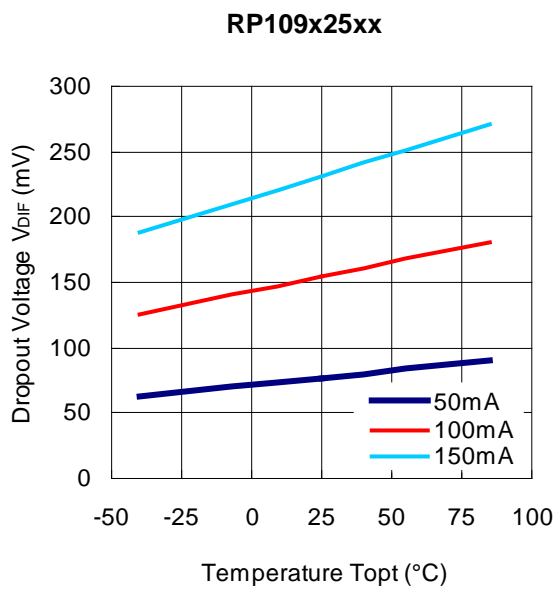
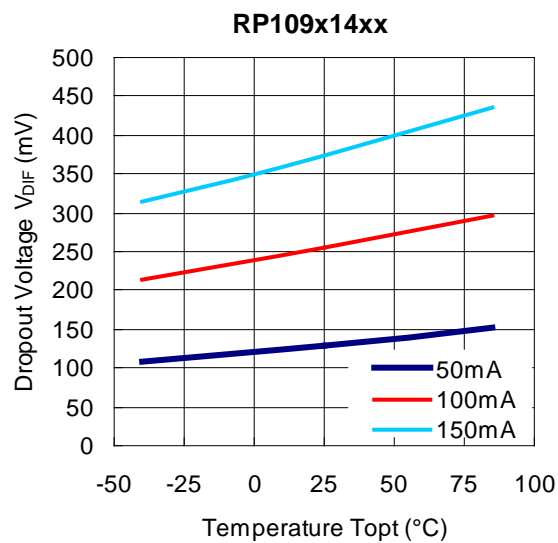
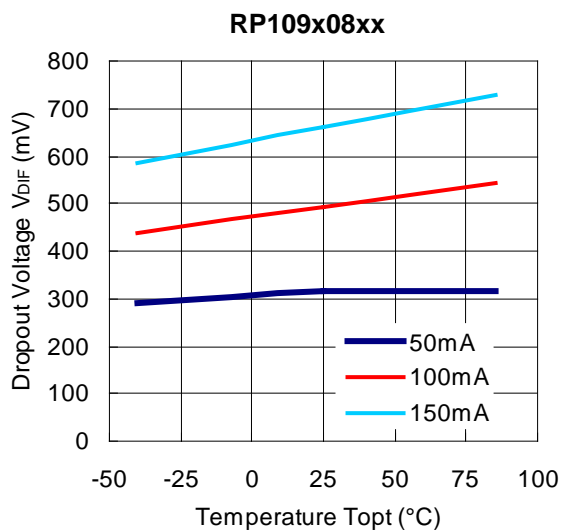

ESR vs. Output Current

When using these ICs, consider the following points:

The relations between I_{OUT} (Output Current) and ESR of an output capacitor are shown below.

The conditions when the white noise level is under $40\mu V$ (Avg.) are marked as the hatched area in the graph.

Measurement conditions

Frequency Band : 10Hz to 2MHz

Temperature : $-40^{\circ}C$ to $85^{\circ}C$

C1, C2 : Ceramic $0.1\mu F$

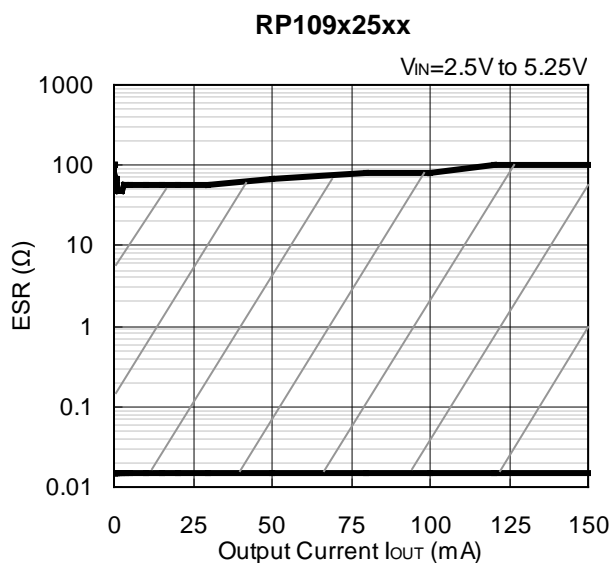
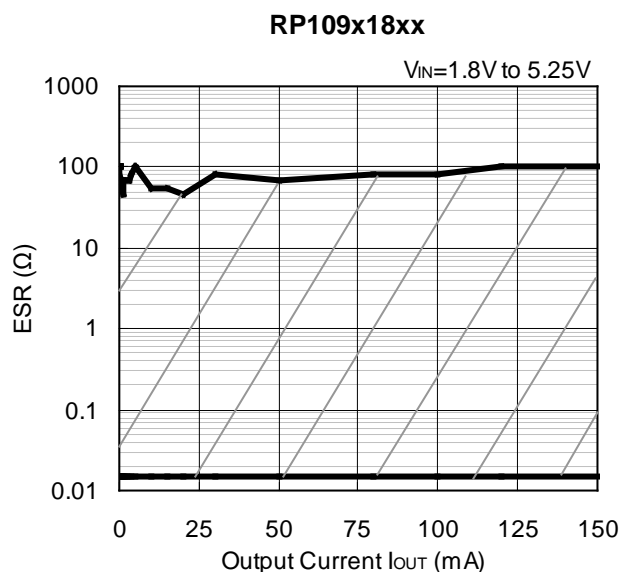
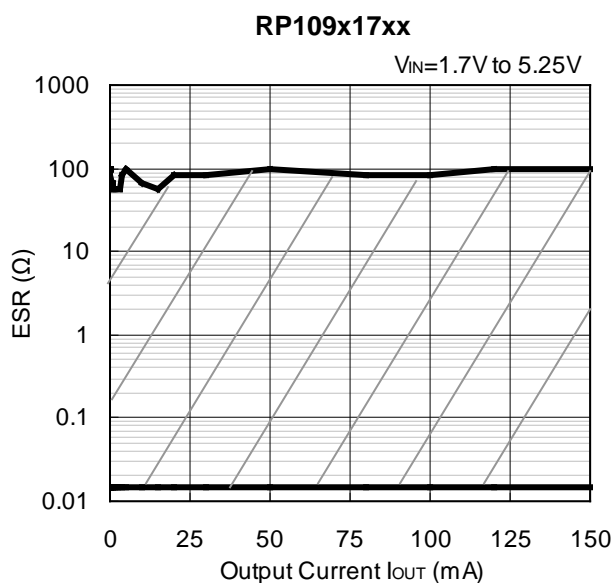
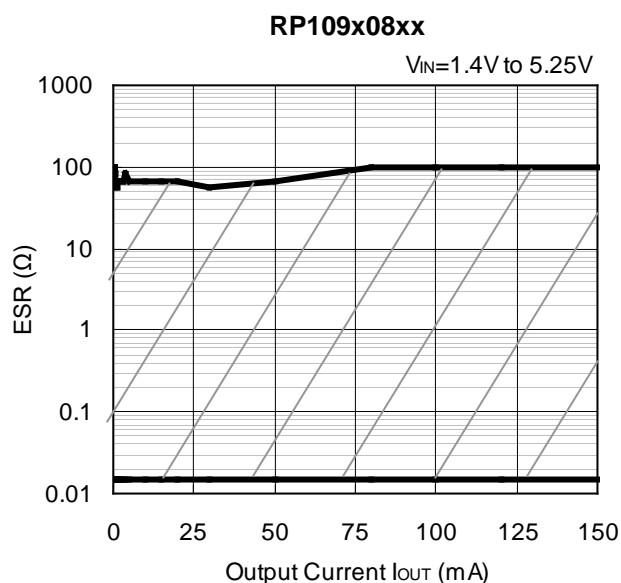

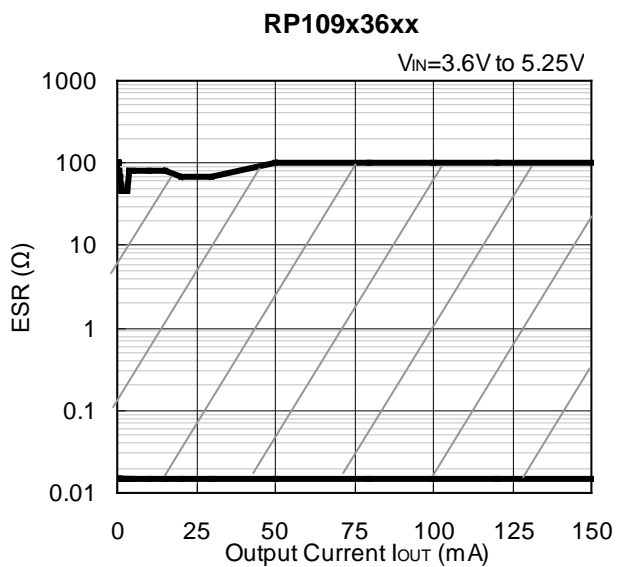

PACKAGE INFORMATION

• Power Dissipation (DFN (PL) 0808-4)

Power Dissipation (P_D) depends on conditions of mounting on board. This specification is based on the measurement at the condition below:

Measurement Conditions:

	Standard Land Pattern
Environment	Mounting on Board (Wind velocity=0m/s)
Board Material	Glass cloth epoxy plastic (Double-sided)
Board Dimensions	40mm × 40mm × 1.6mm
Copper Ratio	Top side: Approx. 50%, Back side: Approx. 50%
Through-holes	φ 0.5mm × 24pcs

Measurement Results:

($T_a=25^{\circ}\text{C}$)

	Standard Land Pattern
Power Dissipation	286mW ($T_{jmax}=125^{\circ}\text{C}$) 358mW ($T_{jmax}=150^{\circ}\text{C}$)
Thermal Resistance	$\theta_{ja} = (125-25^{\circ}\text{C})/0.286\text{W} = 350^{\circ}\text{C/W}$
	$\theta_{jc} = 90^{\circ}\text{C/W}$

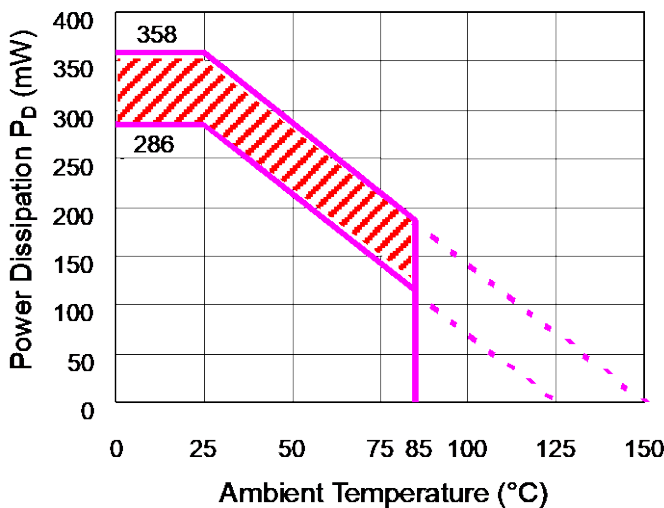

Power Dissipation

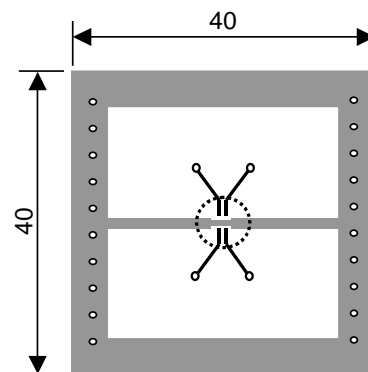

Measurement Board Pattern

○ IC Mount Area (Unit: mm)

The above graph shows the Power Dissipation of the package under the conditions of $T_{jmax}=125^{\circ}\text{C}$ and $T_{jmax}=150^{\circ}\text{C}$.

The operation of the IC within the shaded range in the graph might have an affect on the IC's lifetime.

The operation time of the IC must be remained within the time limit described in the table below.

Operating Time	Estimated Years (Operating 4 hours/day)
13,000 hours	9 years

● **Package Dimensions (DFN (PL) 0808-4)**

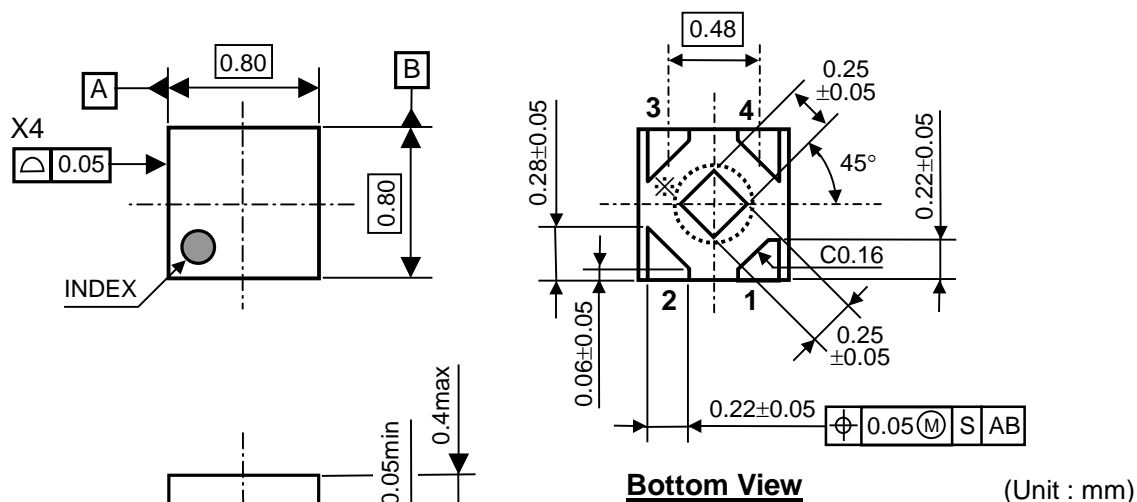

※) Tab is GND level. (They are connected to the reverse side of this IC.)
The tab is better to be connected to the GND, but leaving it open is also acceptable.

● **Mark Specification (DFN (PL) 0808-4)**

- ①: Product Code ... **Refer to “RP109K Series Mark Specification Table”.**
- ②③: Lot Number ... Alphanumeric Serial Number

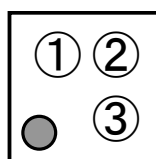

Power Dissipation (DFN1010-4)

Power Dissipation (P_D) depends on conditions of mounting on board. This specification is based on the measurement at the condition below:

Measurement Conditions:

	Standard Land Pattern
Environment	Mounting on Board (Wind velocity=0m/s)
Board Material	Glass cloth epoxy plastic (Double sided)
Board Dimensions	40mm × 40mm × 1.6mm
Copper Ratio	Top side: Approx. 50%, Back side: Approx. 50%
Through-holes	φ 0.54mm × 24pcs

Measurement Results:

($T_a=25^{\circ}\text{C}$)

	Standard Land Pattern
Power Dissipation	400mW ($T_{jmax}=125^{\circ}\text{C}$) 500mW ($T_{jmax}=150^{\circ}\text{C}$)
Thermal Resistance	$\theta_{ja} = (125-25^{\circ}\text{C})/0.4\text{W} = 250^{\circ}\text{C/W}$
	$\theta_{jc} = 67^{\circ}\text{C/W}$

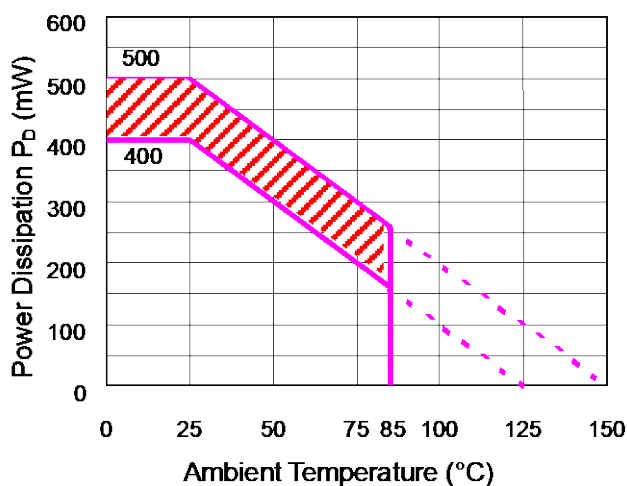

Power Dissipation

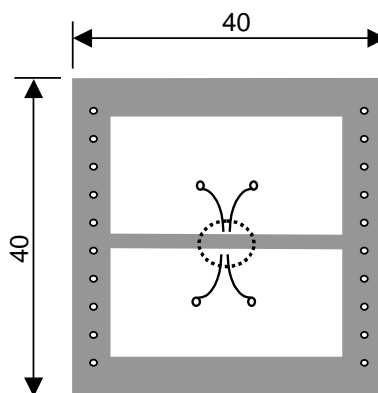

Measurement Board Pattern

○ IC Mount Area (Unit: mm)

The above graph shows the Power Dissipation of the package under the conditions of $T_{jmax}=125^{\circ}\text{C}$ and $T_{jmax}=150^{\circ}\text{C}$.

The operation of the IC within the shaded range in the graph might have an affect on the IC's lifetime.

The operation time of the IC must be remained within the time limit described in the table below.

Operating Time	Estimated Years (Operating 4 hours/day)
13,000 hours	9 years

● **Package Dimensions (DFN1010-4)**

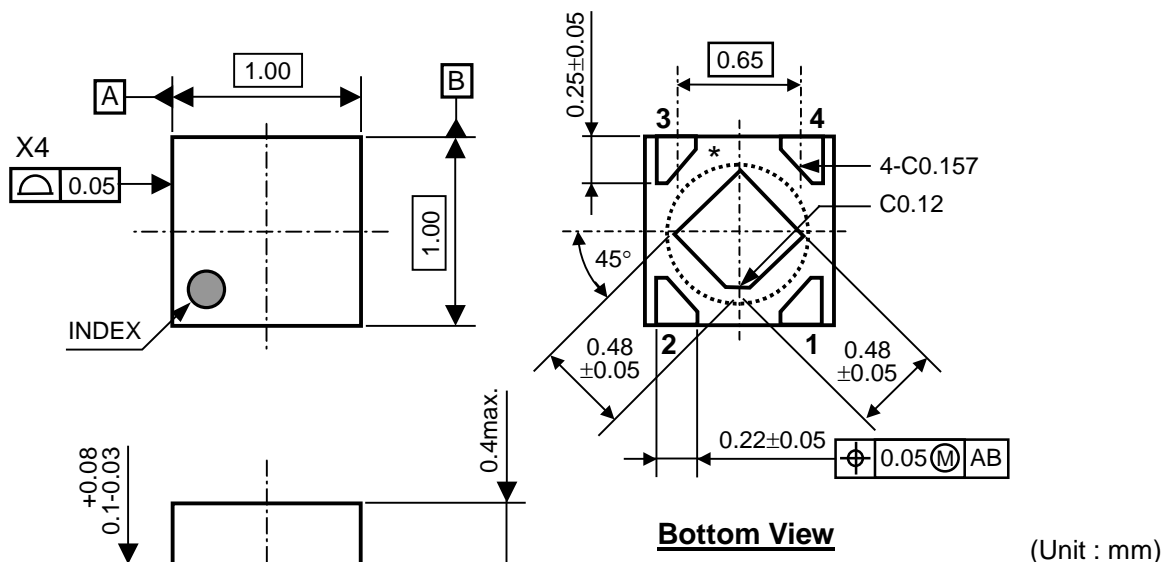

*) Tab is GND level. (They are connected to the reverse side of this IC.)
 The tab is better to be connected to the GND, but leaving it open is also acceptable.

● **Mark Specification (DFN1010-4)**

- ①②: Product Code ... **Refer to "RP109L Series Mark Specification Table".**
- ③④: Lot Number ... Alphanumeric Serial Number

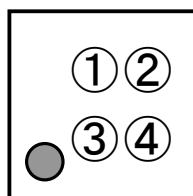

● **Power Dissipation (SOT-23-5)**

Power Dissipation (P_D) depends on conditions of mounting on board. This specification is based on the measurement at the condition below:

(Power Dissipation (SOT-23-5) is substitution of SOT-23-6.)

Measurement Conditions:

	Standard Land Pattern
Environment	Mounting on Board (Wind velocity=0m/s)
Board Material	Glass cloth epoxy plastic (Double sided)
Board Dimensions	40mm × 40mm × 1.6mm
Copper Ratio	Top side: Approx. 50%, Back side: Approx. 50%
Through-holes	φ 0.5mm × 44pcs

Measurement Results:

($T_a=25^{\circ}\text{C}$)

	Standard Land Pattern	Free Air
Power Dissipation	420mW ($T_{jmax}=125^{\circ}\text{C}$) 525mW ($T_{jmax}=150^{\circ}\text{C}$)	250mW
Thermal Resistance	$\theta_{ja} = (125-25^{\circ}\text{C})/0.42\text{W} = 238^{\circ}\text{C/W}$	400 $^{\circ}\text{C/W}$

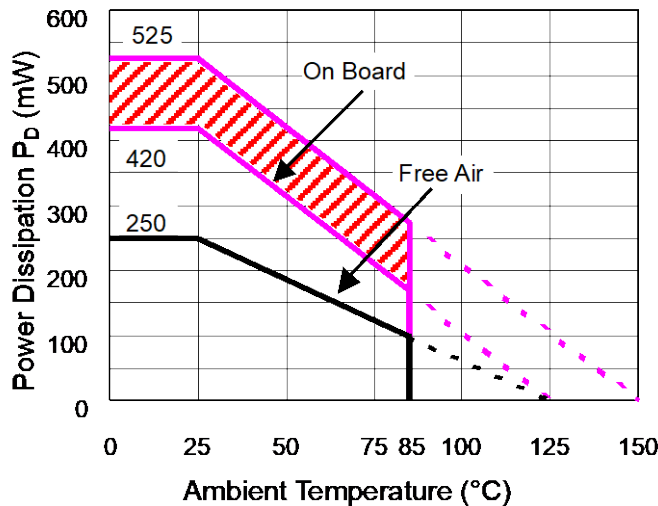

Power Dissipation

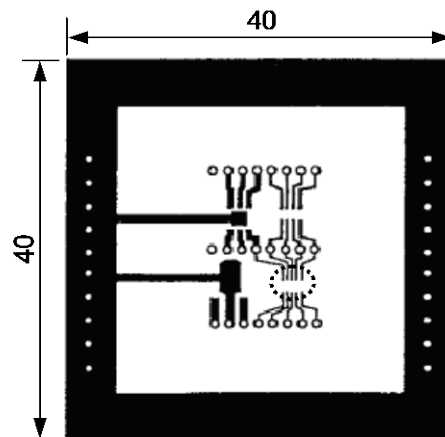

Measurement Board Pattern

○ IC Mount Area (Unit: mm)

The above graph shows the Power Dissipation of the package under the conditions of $T_{jmax}=125^{\circ}\text{C}$ and $T_{jmax}=150^{\circ}\text{C}$.

The operation of the IC within the shaded range in the graph might have an affect on the IC's lifetime.

The operation time of the IC must be remained within the time limit described in the table below.

Operating Time	Estimated Years (Operating 4 hours/day)
13,000 hours	9 years

● Package Dimensions (SOT-23-5)

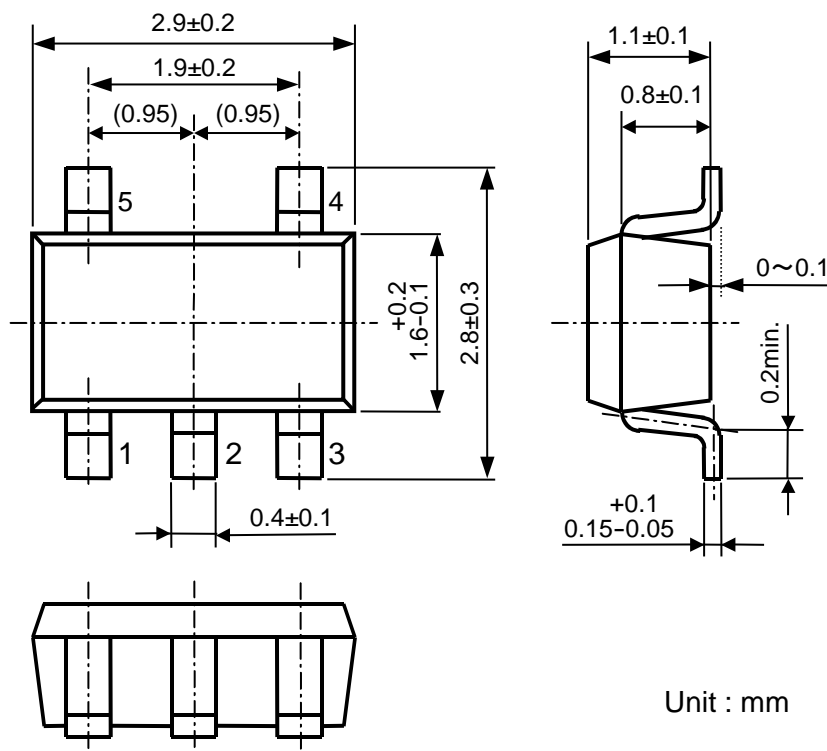

● Mark Specification (SOT-23-5)

①②③: Product Code ... **Refer to "RP109N Mark Specification Table".**

④⑤: Lot Number ... Alphanumeric Serial Number

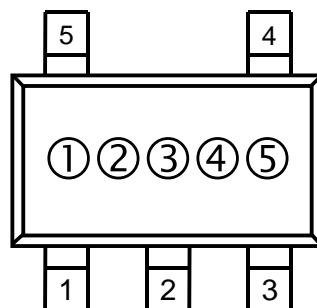

● **Power Dissipation (SC-88A)**

Power Dissipation (P_D) depends on conditions of mounting on board. This specification is based on the measurement at the condition below:

Measurement Conditions:

	Standard Land Pattern
Environment	Mounting on Board (Wind velocity=0m/s)
Board Material	Glass cloth epoxy plastic (Double Layers)
Board Dimensions	40mm × 40mm × 1.6mm
Copper Ratio	Top side: Approx. 50%, Back side: Approx. 50%
Through-hole	φ0.5mm × 44pcs

Measurement Results:

($T_a=25^\circ\text{C}$)

	Standard Land Pattern	Free Air
Power Dissipation	380mW ($T_{jmax}=125^\circ\text{C}$) 475mW ($T_{jmax}=150^\circ\text{C}$)	150mW
Thermal Resistance	$\theta_{ja}=(125-25^\circ\text{C})/0.38\text{W}=263^\circ\text{C/W}$	$\theta_{ja}=(125-25^\circ\text{C})/0.15\text{W}=667^\circ\text{C/W}$
	$\theta_{jc}=75^\circ\text{C/W}$	-

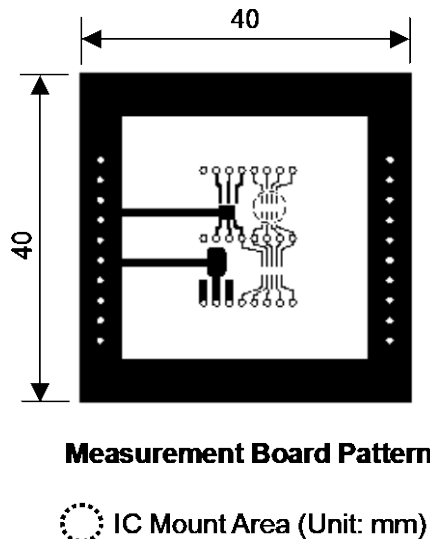
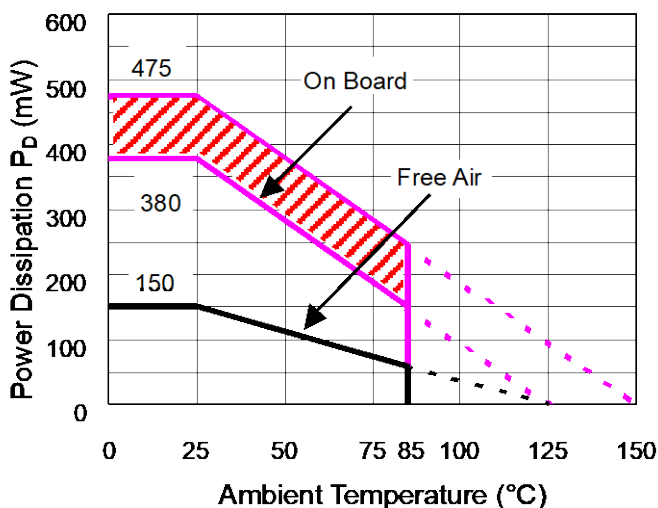

Power Dissipation

The above graph shows the Power Dissipation of the package under the conditions of $T_{jmax}=125^\circ\text{C}$ and $T_{jmax}=150^\circ\text{C}$.

The operation of the IC within the shaded range in the graph might have an affect on the IC's lifetime. The operation time of the IC must be remained within the time limit described in the table below.

Operating Time	Estimated Years (Operating 4 hours/day)
13,000 hours	9 years

● Package Dimensions (SC-88A)

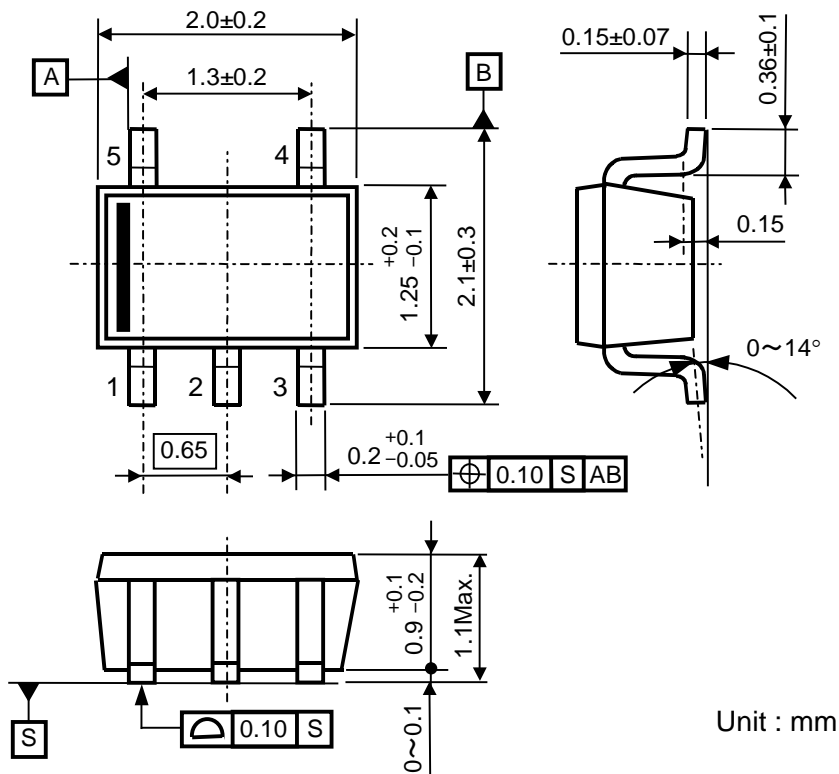

Unit : mm

● Mark Specification (SC-88A)

①②③④: Product Code ...Refer to "RP109Q Series Mark Specification Table".

⑤⑥: Lot Number ... Alphanumeric Serial Number

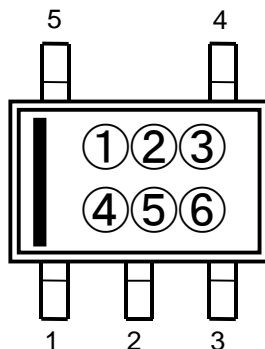

● RP109K Series Mark Specification Table (DFN(PL)0808-4)

RP109Kxx1B

Product Name	①	V _{SET}
RP109K081B	A	0.8V
RP109K091B	A	0.9V
RP109K101B	A	1.0V
RP109K111B	A	1.1V
RP109K121B	A	1.2V
RP109K131B	A	1.3V
RP109K141B	A	1.4V
RP109K151B	A	1.5V
RP109K161B	A	1.6V
RP109K171B	A	1.7V
RP109K181B	A	1.8V
RP109K191B	A	1.9V
RP109K201B	A	2.0V
RP109K211B	A	2.1V
RP109K221B	A	2.2V
RP109K231B	A	2.3V
RP109K241B	A	2.4V
RP109K251B	A	2.5V
RP109K261B	A	2.6V
RP109K271B	A	2.7V
RP109K281B	A	2.8V
RP109K291B	A	2.9V
RP109K301B	A	3.0V
RP109K311B	A	3.1V
RP109K321B	A	3.2V
RP109K331B	A	3.3V
RP109K341B	A	3.4V
RP109K351B	A	3.5V
RP109K361B	A	3.6V
RP109K121B5	A	1.25V
RP109K181B5	A	1.85V
RP109K281B5	A	2.85V
RP109K341B5	A	3.45V
RP109K101B5	A	1.05V
RP109K171B5	A	1.75V
RP109K111B5	A	1.15V

RP109Kxx1D

Product Name	①	V _{SET}
RP109K081D	A	0.8V
RP109K091D	A	0.9V
RP109K101D	A	1.0V
RP109K111D	A	1.1V
RP109K121D	A	1.2V
RP109K131D	A	1.3V
RP109K141D	A	1.4V
RP109K151D	A	1.5V
RP109K161D	A	1.6V
RP109K171D	A	1.7V
RP109K181D	A	1.8V
RP109K191D	A	1.9V
RP109K201D	A	2.0V
RP109K211D	A	2.1V
RP109K221D	A	2.2V
RP109K231D	A	2.3V
RP109K241D	A	2.4V
RP109K251D	A	2.5V
RP109K261D	A	2.6V
RP109K271D	A	2.7V
RP109K281D	A	2.8V
RP109K291D	A	2.9V
RP109K301D	A	3.0V
RP109K311D	A	3.1V
RP109K321D	A	3.2V
RP109K331D	A	3.3V
RP109K341D	A	3.4V
RP109K351D	A	3.5V
RP109K361D	A	3.6V
RP109K121D5	A	1.25V
RP109K181D5	A	1.85V
RP109K281D5	A	2.85V
RP109K341D5	A	3.45V
RP109K101D5	A	1.05V
RP109K171D5	A	1.75V
RP109K111D5	A	1.15V

RP109L Series Mark Specification Table (DFN1010-4)

RP109Lxx1B

Product Name	①②	V _{SET}
RP109L081B	C0	0.8V
RP109L091B	C1	0.9V
RP109L101B	C2	1.0V
RP109L111B	C3	1.1V
RP109L121B	C4	1.2V
RP109L131B	C5	1.3V
RP109L141B	C6	1.4V
RP109L151B	C7	1.5V
RP109L161B	C8	1.6V
RP109L171B	C9	1.7V
RP109L181B	D0	1.8V
RP109L191B	D1	1.9V
RP109L201B	D2	2.0V
RP109L211B	D3	2.1V
RP109L221B	D4	2.2V
RP109L231B	D5	2.3V
RP109L241B	D6	2.4V
RP109L251B	D7	2.5V
RP109L261B	D8	2.6V
RP109L271B	D9	2.7V
RP109L281B	E0	2.8V
RP109L291B	E1	2.9V
RP109L301B	E2	3.0V
RP109L311B	E3	3.1V
RP109L321B	E4	3.2V
RP109L331B	E5	3.3V
RP109L341B	E6	3.4V
RP109L351B	E7	3.5V
RP109L361B	E8	3.6V
RP109L121B5	E9	1.25V
RP109L181B5	J0	1.85V
RP109L281B5	J1	2.85V
RP109L341B5	J2	3.45V
RP109L101B5	J4	1.05V
RP109L171B5	J5	1.75V
RP109L111B5	J6	1.15V
RP109L081B5	J7	0.85V

RP109Lxx1D

Product Name	①②	V _{SET}
RP109L081D	F0	0.8V
RP109L091D	F1	0.9V
RP109L101D	F2	1.0V
RP109L111D	F3	1.1V
RP109L121D	F4	1.2V
RP109L131D	F5	1.3V
RP109L141D	F6	1.4V
RP109L151D	F7	1.5V
RP109L161D	F8	1.6V
RP109L171D	F9	1.7V
RP109L181D	G0	1.8V
RP109L191D	G1	1.9V
RP109L201D	G2	2.0V
RP109L211D	G3	2.1V
RP109L221D	G4	2.2V
RP109L231D	G5	2.3V
RP109L241D	G6	2.4V
RP109L251D	G7	2.5V
RP109L261D	G8	2.6V
RP109L271D	G9	2.7V
RP109L281D	H0	2.8V
RP109L291D	H1	2.9V
RP109L301D	H2	3.0V
RP109L311D	H3	3.1V
RP109L321D	H4	3.2V
RP109L331D	H5	3.3V
RP109L341D	H6	3.4V
RP109L351D	H7	3.5V
RP109L361D	H8	3.6V
RP109L121D5	H9	1.25V
RP109L181D5	K0	1.85V
RP109L281D5	K1	2.85V
RP109L341D5	K2	3.45V
RP109L101D5	K4	1.05V
RP109L171D5	K5	1.75V
RP109L111D5	K6	1.15V
RP109L081D5	K7	0.85V

● RP109N Series Mark Specification Table (SOT-23-5)

RP109Nxx1B			RP109Nxx1D		
Product Name	①②③	V _{SET}	Product Name	①②③	V _{SET}
RP109N081B	NAA	0.8V	RP109N081D	NBA	0.8V
RP109N091B	NAB	0.9V	RP109N091D	NBB	0.9V
RP109N101B	NAC	1.0V	RP109N101D	NBC	1.0V
RP109N111B	NAD	1.1V	RP109N111D	NBD	1.1V
RP109N121B	NAE	1.2V	RP109N121D	NBE	1.2V
RP109N131B	NAF	1.3V	RP109N131D	NBF	1.3V
RP109N141B	NAG	1.4V	RP109N141D	NBG	1.4V
RP109N151B	NAH	1.5V	RP109N151D	NBH	1.5V
RP109N161B	NAJ	1.6V	RP109N161D	NBJ	1.6V
RP109N171B	NAK	1.7V	RP109N171D	NBK	1.7V
RP109N181B	NAL	1.8V	RP109N181D	NBL	1.8V
RP109N191B	NAM	1.9V	RP109N191D	NBM	1.9V
RP109N201B	NAN	2.0V	RP109N201D	NBN	2.0V
RP109N211B	NAP	2.1V	RP109N211D	NBP	2.1V
RP109N221B	NAQ	2.2V	RP109N221D	NBQ	2.2V
RP109N231B	NAR	2.3V	RP109N231D	NBR	2.3V
RP109N241B	NAS	2.4V	RP109N241D	NBS	2.4V
RP109N251B	NAT	2.5V	RP109N251D	NBT	2.5V
RP109N261B	NAU	2.6V	RP109N261D	NBU	2.6V
RP109N271B	NAV	2.7V	RP109N271D	NBV	2.7V
RP109N281B	NAW	2.8V	RP109N281D	NBW	2.8V
RP109N291B	NAX	2.9V	RP109N291D	NBX	2.9V
RP109N301B	NAY	3.0V	RP109N301D	NBY	3.0V
RP109N311B	NAZ	3.1V	RP109N311D	NBZ	3.1V
RP109N321B	PAA	3.2V	RP109N321D	PBA	3.2V
RP109N331B	PAB	3.3V	RP109N331D	PBB	3.3V
RP109N341B	PAC	3.4V	RP109N341D	PBC	3.4V
RP109N351B	PAD	3.5V	RP109N351D	PBD	3.5V
RP109N361B	PAE	3.6V	RP109N361D	PBE	3.6V
RP109N121B5	PAF	1.25V	RP109N121D5	PBF	1.25V
RP109N181B5	PAG	1.85V	RP109N181D5	PBG	1.85V
RP109N281B5	PAH	2.85V	RP109N281D5	PBH	2.85V
RP109N341B5	PAJ	3.45V	RP109N341D5	PBJ	3.45V
RP109N101B5	PAK	1.05V	RP109N101D5	PBK	1.05V
RP109N171B5	PAL	1.75V	RP109N171D5	PBL	1.75V
RP109N111B5	PAM	1.15V	RP109N111D5	PBM	1.15V
RP109N081B5	PAN	0.85V	RP109N081D5	PBN	0.85V

● RP109Q Series Mark Specification Table (SC-88A)

RP109Qxx2B

Product Name	①②③④	V _{SET}
RP109Q082B	AE08	0.8V
RP109Q092B	AE09	0.9V
RP109Q102B	AE10	1.0V
RP109Q112B	AE11	1.1V
RP109Q122B	AE12	1.2V
RP109Q132B	AE13	1.3V
RP109Q142B	AE14	1.4V
RP109Q152B	AE15	1.5V
RP109Q162B	AE16	1.6V
RP109Q172B	AE17	1.7V
RP109Q182B	AE18	1.8V
RP109Q192B	AE19	1.9V
RP109Q201B	AE20	2.0V
RP109Q212B	AE21	2.1V
RP109Q222B	AE22	2.2V
RP109Q232B	AE23	2.3V
RP109Q242B	AE24	2.4V
RP109Q252B	AE25	2.5V
RP109Q262B	AE26	2.6V
RP109Q272B	AE27	2.7V
RP109Q282B	AE28	2.8V
RP109Q292B	AE29	2.9V
RP109Q302B	AE30	3.0V
RP109Q312B	AE31	3.1V
RP109Q322B	AE32	3.2V
RP109Q332B	AE33	3.3V
RP109Q342B	AE34	3.4V
RP109Q352B	AE35	3.5V
RP109Q362B	AE36	3.6V
RP109Q122B5	AE37	1.25V
RP109Q182B5	AE38	1.85V
RP109Q282B5	AE39	2.85V
RP109Q342B5	AE40	3.45V
RP109Q102B5	AE41	1.05V
RP109Q172B5	AE42	1.75V
RP109Q112B5	AE43	1.15V

RP109Qxx2D

Product Name	①②③④	V _{SET}
RP109Q082D	AF08	0.8V
RP109Q092D	AF09	0.9V
RP109Q102D	AF10	1.0V
RP109Q112D	AF11	1.1V
RP109Q122D	AF12	1.2V
RP109Q132D	AF13	1.3V
RP109Q142D	AF14	1.4V
RP109Q152D	AF15	1.5V
RP109Q162D	AF16	1.6V
RP109Q172D	AF17	1.7V
RP109Q182D	AF18	1.8V
RP109Q192D	AF19	1.9V
RP109Q202D	AF20	2.0V
RP109Q212D	AF21	2.1V
RP109Q222D	AF22	2.2V
RP109Q232D	AF23	2.3V
RP109Q242D	AF24	2.4V
RP109Q252D	AF25	2.5V
RP109Q262D	AF26	2.6V
RP109Q272D	AF27	2.7V
RP109Q282D	AF28	2.8V
RP109Q292D	AF29	2.9V
RP109Q302D	AF30	3.0V
RP109Q312D	AF31	3.1V
RP109Q322D	AF32	3.2V
RP109Q332D	AF33	3.3V
RP109Q342D	AF34	3.4V
RP109Q352D	AF35	3.5V
RP109Q362D	AF36	3.6V
RP109Q122D5	AF37	1.25V
RP109Q182D5	AF38	1.85V
RP109Q282D5	AF39	2.85V
RP109Q342D5	AF40	3.45V
RP109Q102D5	AF41	1.05V
RP109Q172D5	AF42	1.75V
RP109Q112D5	AF43	1.15V

1. The products and the product specifications described in this document are subject to change or discontinuation of production without notice for reasons such as improvement. Therefore, before deciding to use the products, please refer to our sales representatives for the latest information thereon.
2. The materials in this document may not be copied or otherwise reproduced in whole or in part without the prior written consent of us.
3. This product and any technical information relating thereto are subject to complementary export controls (so-called KNOW controls) under the Foreign Exchange and Foreign Trade Law, and related politics ministerial ordinance of the law. (Note that the complementary export controls are inapplicable to any application-specific products, except rockets and pilotless aircraft, that are insusceptible to design or program changes.) Accordingly, when exporting or carrying abroad this product, follow the Foreign Exchange and Foreign Trade Control Law and its related regulations with respect to the complementary export controls.
4. The technical information described in this document shows typical characteristics and example application circuits for the products. The release of such information is not to be construed as a warranty of or a grant of license under our or any third party's intellectual property rights or any other rights.
5. The products listed in this document are intended and designed for use as general electronic components in standard applications (office equipment, telecommunication equipment, measuring instruments, consumer electronic products, amusement equipment etc.). Those customers intending to use a product in an application requiring extreme quality and reliability, for example, in a highly specific application where the failure or misoperation of the product could result in human injury or death should first contact us.
 - Aerospace Equipment
 - Equipment Used in the Deep Sea
 - Power Generator Control Equipment (nuclear, steam, hydraulic, etc.)
 - Life Maintenance Medical Equipment
 - Fire Alarms / Intruder Detectors
 - Vehicle Control Equipment (automotive, airplane, railroad, ship, etc.)
 - Various Safety Devices
 - Traffic control system
 - Combustion equipment

In case your company desires to use this product for any applications other than general electronic equipment mentioned above, make sure to contact our company in advance. Note that the important requirements mentioned in this section are not applicable to cases where operation requirements such as application conditions are confirmed by our company in writing after consultation with your company.

6. We are making our continuous effort to improve the quality and reliability of our products, but semiconductor products are likely to fail with certain probability. In order to prevent any injury to persons or damages to property resulting from such failure, customers should be careful enough to incorporate safety measures in their design, such as redundancy feature, fire containment feature and fail-safe feature. We do not assume any liability or responsibility for any loss or damage arising from misuse or inappropriate use of the products.
7. The products have been designed and tested to function within controlled environmental conditions. Do not use products under conditions that deviate from methods or applications specified in this datasheet. Failure to employ the products in the proper applications can lead to deterioration, destruction or failure of the products. We shall not be responsible for any bodily injury, fires or accident, property damage or any consequential damages resulting from misuse or misapplication of the products.
8. **Quality Warranty**
 - 8-1. **Quality Warranty Period**

In the case of a product purchased through an authorized distributor or directly from us, the warranty period for this product shall be one (1) year after delivery to your company. For defective products that occurred during this period, we will take the quality warranty measures described in section 8-2. However, if there is an agreement on the warranty period in the basic transaction agreement, quality assurance agreement, delivery specifications, etc., it shall be followed.
 - 8-2. **Quality Warranty Remedies**

When it has been proved defective due to manufacturing factors as a result of defect analysis by us, we will either deliver a substitute for the defective product or refund the purchase price of the defective product.

Note that such delivery or refund is sole and exclusive remedies to your company for the defective product.
 - 8-3. **Remedies after Quality Warranty Period**

With respect to any defect of this product found after the quality warranty period, the defect will be analyzed by us. On the basis of the defect analysis results, the scope and amounts of damage shall be determined by mutual agreement of both parties. Then we will deal with upper limit in Section 8-2. This provision is not intended to limit any legal rights of your company.
9. Anti-radiation design is not implemented in the products described in this document.
10. The X-ray exposure can influence functions and characteristics of the products. Confirm the product functions and characteristics in the evaluation stage.
11. WLCSP products should be used in light shielded environments. The light exposure can influence functions and characteristics of the products under operation or storage.
12. Warning for handling Gallium and Arsenic (GaAs) products (Applying to GaAs MMIC, Photo Reflector). These products use Gallium (Ga) and Arsenic (As) which are specified as poisonous chemicals by law. For the prevention of a hazard, do not burn, destroy, or process chemically to make them as gas or power. When the product is disposed of, please follow the related regulation and do not mix this with general industrial waste or household waste.
13. Please contact our sales representatives should you have any questions or comments concerning the products or the technical information.



Nisshinbo Micro Devices Inc.

Official website

<https://www.nisshinbo-microdevices.co.jp/en/>

Purchase information

<https://www.nisshinbo-microdevices.co.jp/en/buy/>

OUR CERTIFICATE

DiGi provide top-quality products and perfect service for customer worldwide through standardization, technological innovation and continuous improvement. DiGi through third-party certification, we stricly control the quality of products and services. Welcome your RFQ to

Email: Info@DiGi-Electronics.com



Tel: +00 852-30501935

RFQ Email: Info@DiGi-Electronics.com

DiGi is a global authorized distributor of electronic components.