

# AT25128B-MAHL-E Datasheet

[www.digi-electronics.com](http://www.digi-electronics.com)

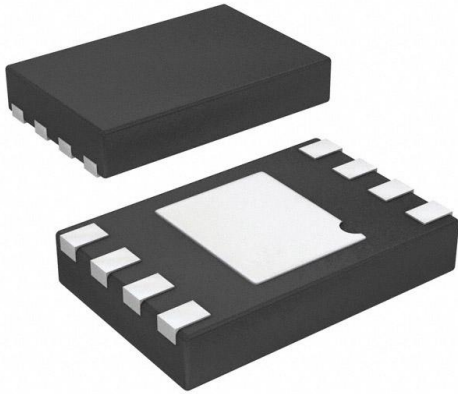

<https://www.DiGi-Electronics.com>

DiGi Electronics Part Number	AT25128B-MAHL-E-DG
Manufacturer	<a href="#">Microchip Technology</a>
Manufacturer Product Number	AT25128B-MAHL-E
Description	IC EEPROM 128KBIT SPI 8UDFN
Detailed Description	EEPROM Memory IC 128Kbit SPI 20 MHz 8-UDFN (2x 3)

This model AT25128B-MAHL-E is available at DiGi Electronics.

DiGi Electronics offers a global database of semiconductor and electronic component datasheets.

We welcome your inquiries regarding pricing, lead time, or other product-related questions.

 [Request a Quote](#)

 [Datasheet Search](#)



Tel: +00 852-30501935

RFQ Email: [Info@DiGi-Electronics.com](mailto:Info@DiGi-Electronics.com)

DiGi is a global authorized distributor of electronic components.

## Purchase and inquiry

Manufacturer Product Number:

AT25128B-MAHL-E

Series:

-

DiGi-Electronics Programmable:

Not Verified

Memory Format:

EEPROM

Memory Size:

128Kbit

Memory Interface:

SPI

Write Cycle Time - Word, Page:

5ms

Operating Temperature:

-40°C ~ 85°C (TA)

Package / Case:

8-UFDFN Exposed Pad

Base Product Number:

AT25128

Manufacturer:

Microchip Technology

Product Status:

Active

Memory Type:

Non-Volatile

Technology:

EEPROM

Memory Organization:

16K x 8

Clock Frequency:

20 MHz

Voltage - Supply:

1.8V ~ 5.5V

Mounting Type:

Surface Mount

Supplier Device Package:

8-UDFN (2x3)

## Environmental & Export classification

RoHS Status:

ROHS3 Compliant

REACH Status:

REACH Unaffected

HTSUS:

8542.32.0051

Moisture Sensitivity Level (MSL):

3 (168 Hours)

ECCN:

EAR99



# AT25128B/AT25256B

---

## SPI Serial EEPROM 128 Kbits (16,384 x 8) and 256 Kbits (32,768 x 8)

---

### Features

---

- Serial Peripheral Interface (SPI) Compatible
- Supports SPI Modes 0 (0,0) and 3 (1,1):
  - Data sheet describes mode 0 operation
- Low-Voltage Operation:
  - 1.8V ( $V_{CC} = 1.8V$  to 5.5V)
- Industrial Temperature Range: -40°C to +85°C
- 20 MHz Clock Rate (5V)
- 64-Byte Page Mode
- Block Write Protection:
  - Protect 1/4, 1/2 or entire array
- Write-Protect ( $\overline{WP}$ ) Pin and Write Disable Instructions for Both Hardware and Software Data Protection
- Self-Timed Write Cycle within 5 ms Maximum
- ESD Protection > 4,000V
- High Reliability:
  - Endurance: 1,000,000 write cycles
  - Data retention: 100 years
- Green (Lead-free/Halide-free/RoHS Compliant) Package Options
- Die Sale Options: Wafer Form and Bumped Wafers

### Packages

---

- 8-Lead SOIC, 8-Lead TSSOP, 8-Pad UDFN and 8-Ball VFBGA

**Table of Contents**

Features.....	1
Packages.....	1
1. Package Types (not to scale).....	4
2. Pin Description.....	5
2.1. Chip Select ( $\overline{CS}$ ).....	5
2.2. Serial Data Output (SO).....	5
2.3. Write-Protect ( $\overline{WP}$ ).....	5
2.4. Ground (GND).....	5
2.5. Serial Data Input (SI).....	6
2.6. Serial Data Clock (SCK).....	6
2.7. Suspend Serial Input ( $\overline{HOLD}$ ).....	6
2.8. Device Power Supply ( $V_{CC}$ ).....	6
3. Description.....	7
3.1. SPI Bus Master Connections to Serial EEPROMs.....	7
3.2. Block Diagram.....	8
4. Electrical Characteristics.....	9
4.1. Absolute Maximum Ratings.....	9
4.2. DC and AC Operating Range.....	9
4.3. DC Characteristics.....	9
4.4. AC Characteristics.....	10
4.5. SPI Synchronous Data Timing.....	13
4.6. Electrical Specifications.....	13
5. Device Operation.....	15
5.1. Interfacing the AT25128B/AT25256B on the SPI Bus.....	15
5.2. Device Opcodes.....	16
5.3. Hold Function.....	16
5.4. Write Protection.....	17
6. Device Commands and Addressing.....	18
6.1. STATUS Register Bit Definition and Function.....	18
6.2. Read STATUS Register ( $RDSR$ ).....	19
6.3. Write Enable ( $WREN$ ) and Write Disable ( $WRDI$ ).....	19
6.4. Write STATUS Register ( $WRSR$ ).....	20
7. Read Sequence.....	23
8. Write Sequence.....	24
8.1. Byte Write.....	24
8.2. Page Write.....	25

---

---

8.3. Polling Routine.....	25
9. Packaging Information.....	27
9.1. Package Marking Information.....	27
10. Revision History.....	37
The Microchip Web Site.....	38
Customer Change Notification Service.....	38
Customer Support.....	38
Product Identification System.....	39
Microchip Devices Code Protection Feature.....	39
Legal Notice.....	40
Trademarks.....	40
Quality Management System Certified by DNV.....	41
Worldwide Sales and Service.....	42

**AT25128B/AT25256B**

Package Types (not to scale)

**1. Package Types (not to scale)****8-Lead SOIC/TSSOP**

(Top View)

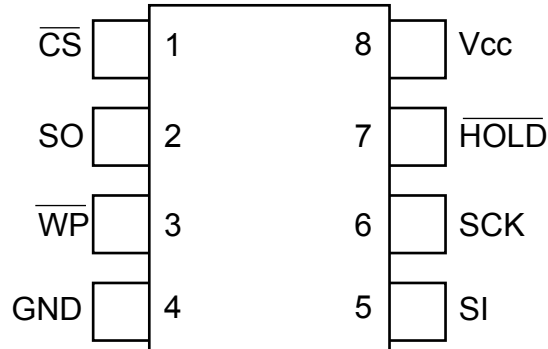
**8-Pad UDFN**

(Top View)

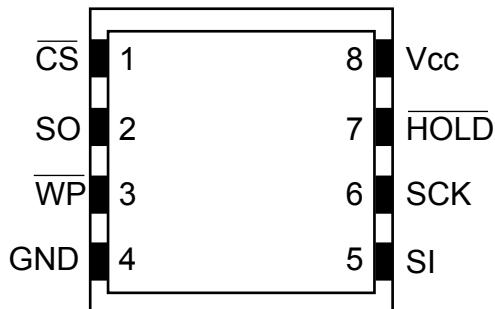
**8-Ball VFBGA**

(Top View)

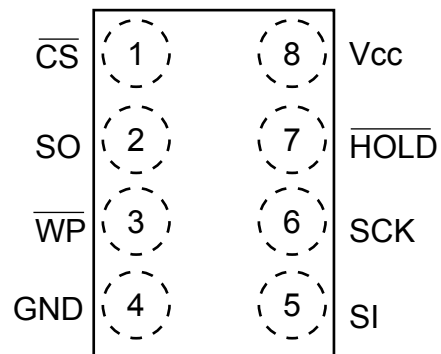

## 2. Pin Description

The descriptions of the pins are listed in [Table 2-1](#).

**Table 2-1. Pin Function Table**

Name	8-Lead SOIC	8-Lead TSSOP	8-Pad UDFN <sup>(1)</sup>	8-Ball VFBGA	Function
$\overline{\text{CS}}$	1	1	1	1	Chip Select
SO	2	2	2	2	Serial Data Output
$\overline{\text{WP}}$ <sup>(2)</sup>	3	3	3	3	Write-Protect
GND	4	4	4	4	Ground
SI	5	5	5	5	Serial Data Input
SCK	6	6	6	6	Serial Data Clock
$\overline{\text{HOLD}}$ <sup>(2)</sup>	7	7	7	7	Suspends Serial Input
V <sub>CC</sub>	8	8	8	8	Device Power Supply

**Note:**

1. The exposed pad on this package can be connected to GND or left floating.
2. The Write-Protect ( $\overline{\text{WP}}$ ) and Hold ( $\overline{\text{HOLD}}$ ) pins should be driven high or low as appropriate.

### 2.1 Chip Select ( $\overline{\text{CS}}$ )

The AT25128B/AT25256B is selected when the Chip Select ( $\overline{\text{CS}}$ ) pin is low. When the device is not selected, data will not be accepted via the Serial Data Input (SI) pin, and the Serial Output (SO) pin will remain in a high-impedance state.

To ensure robust operation, the  $\overline{\text{CS}}$  pin should follow V<sub>CC</sub> upon power-up. It is therefore recommended to connect  $\overline{\text{CS}}$  to V<sub>CC</sub> using a pull-up resistor (less than or equal to 10 k $\Omega$ ). After power-up, a low level on  $\overline{\text{CS}}$  is required prior to any sequence being initiated.

### 2.2 Serial Data Output (SO)

The Serial Data Output (SO) pin is used to transfer data out of the AT25128B/AT25256B. During a read sequence, data is shifted out on this pin after the falling edge of the Serial Data Clock (SCK).

### 2.3 Write-Protect ( $\overline{\text{WP}}$ )

The Write-Protect ( $\overline{\text{WP}}$ ) pin will allow normal read/write operations when held high. When the  $\overline{\text{WP}}$  pin is brought low and WPEN bit is set to a logic '1', all write operations to the STATUS register are inhibited.  $\overline{\text{WP}}$  going low while  $\overline{\text{CS}}$  is still low will interrupt a write operation to the STATUS register. If the internal write cycle has already been initiated,  $\overline{\text{WP}}$  going low will have no effect on any write operation to the STATUS register. The  $\overline{\text{WP}}$  pin function is blocked when the WPEN bit in the STATUS register is set to a logic '0'. This will allow the user to install the AT25128B/AT25256B in a system with the  $\overline{\text{WP}}$  pin tied to ground and still be able to write to the STATUS register. All  $\overline{\text{WP}}$  pin functions are enabled when the WPEN bit is set to a logic '1'.

### 2.4 Ground (GND)

The ground reference for the Device Power Supply (V<sub>CC</sub>). The Ground (GND) pin should be connected to the system ground.

## 2.5 Serial Data Input (SI)

The Serial Data Input (SI) pin is used to transfer data into the device. It receives instructions, addresses and data. Data is latched on the rising edge of the Serial Data Clock (SCK).

## 2.6 Serial Data Clock (SCK)

The Serial Data Clock (SCK) pin is used to synchronize the communication between a master and the AT25128B/AT25256B. Instructions, addresses or data present on the Serial Data Input (SI) pin is latched in on the rising edge of SCK, while output on the Serial Data Output (SO) pin is clocked out on the falling edge of SCK.

## 2.7 Suspend Serial Input ( $\overline{\text{HOLD}}$ )

The Suspend Serial Input ( $\overline{\text{HOLD}}$ ) pin is used in conjunction with the Chip Select ( $\overline{\text{CS}}$ ) pin to pause the AT25128B/AT25256B. When the device is selected and a serial sequence is underway,  $\overline{\text{HOLD}}$  can be used to pause the serial communication with the master device without resetting the serial sequence. To pause, the  $\overline{\text{HOLD}}$  pin must be brought low while the Serial Data Clock (SCK) pin is low. To resume serial communication, the  $\overline{\text{HOLD}}$  pin is brought high while the SCK pin is low (SCK may still toggle during  $\overline{\text{HOLD}}$ ). Inputs to the Serial Data Input (SI) pin will be ignored while the Serial Data Output (SO) pin will be in the high-impedance state.

## 2.8 Device Power Supply ( $V_{CC}$ )

The Device Power Supply ( $V_{CC}$ ) pin is used to supply the source voltage to the device. Operations at invalid  $V_{CC}$  voltages may produce spurious results and should not be attempted.

### 3. Description

The AT25128B/AT25256B provides 131,072/262,144 bits of Serial Electrically Erasable and Programmable Read-Only Memory (EEPROM) organized as 16,384/32,768 words of 8 bits each. The device is optimized for use in many industrial and commercial applications where low-power and low-voltage operation are essential. The device is available in space-saving 8-lead SOIC, 8-lead TSSOP, 8-pad UDFN and 8-ball VFBGA packages. All packages operate from 1.8V to 5.5V.

#### 3.1 SPI Bus Master Connections to Serial EEPROMs

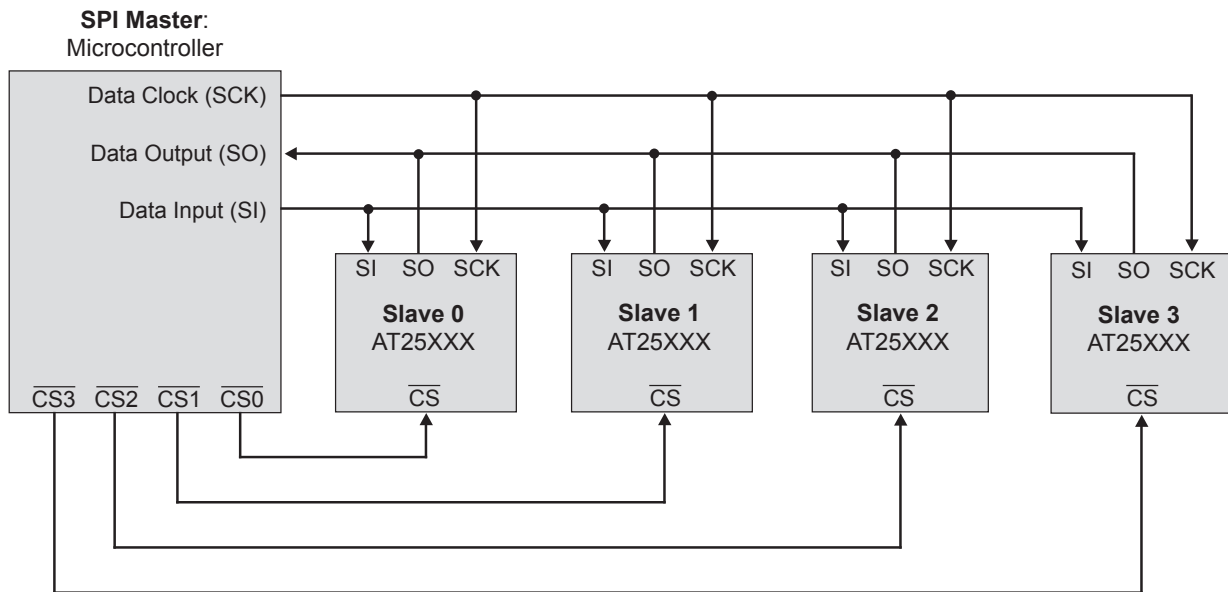

### 3.2 Block Diagram

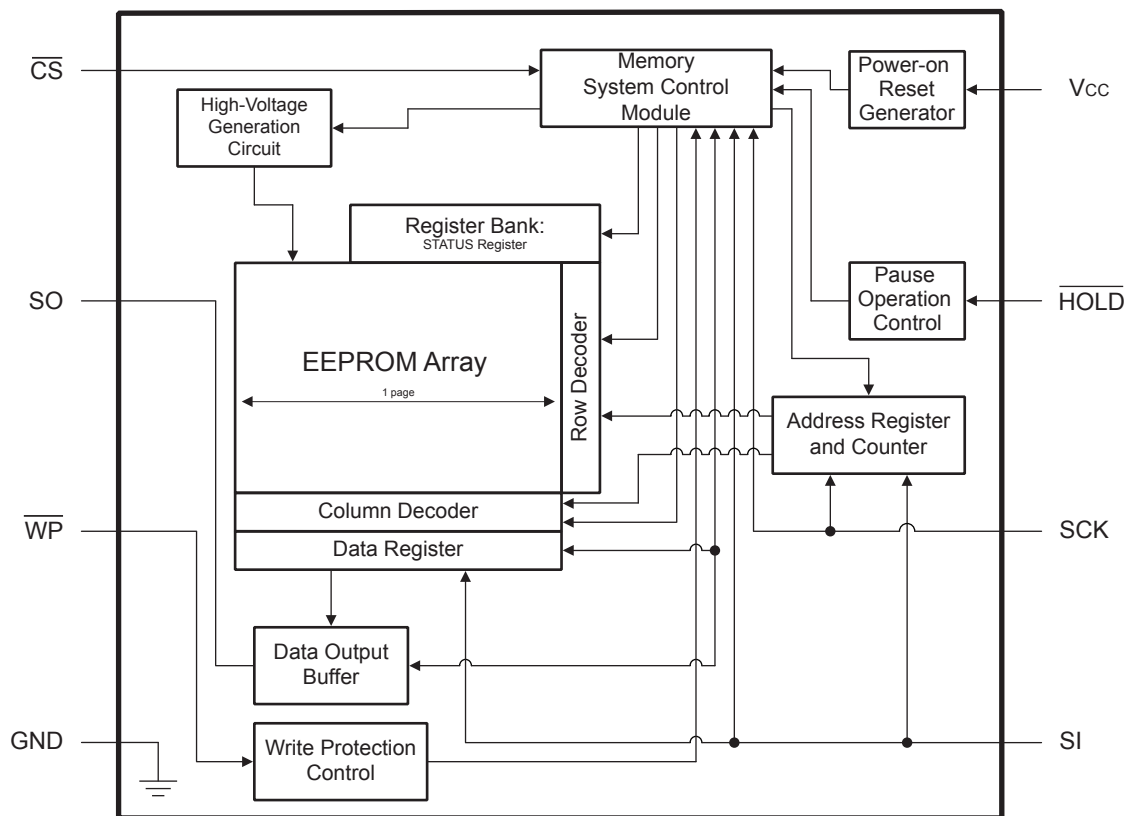

**AT25128B/AT25256B****Electrical Characteristics****4. Electrical Characteristics****4.1 Absolute Maximum Ratings**

<b>Operating temperature</b>	-55°C to +125°C
<b>Storage temperature</b>	-65°C to +150°C
<b>Voltage on any pin with respect to ground</b>	-1.0V to +7.0V
<b>V<sub>CC</sub></b>	6.25V
<b>DC output current</b>	5.0 mA
<b>ESD protection</b>	> 4 kV

**Note:** Stresses above those listed under “Absolute Maximum Ratings” may cause permanent damage to the device. This is a stress rating only and functional operation of the device at these or any other conditions above those indicated in the operation listings of this specification is not implied. Exposure to absolute maximum rating conditions for extended periods may affect device reliability.

**4.2 DC and AC Operating Range****Table 4-1. DC and AC Operating Range**

AT25128B/AT25256B		
Operating Temperature (Case)	Industrial Temperature Range	-40°C to +85°C
V <sub>CC</sub> Power Supply	Low-Voltage Grade	1.8V to 5.5V

**4.3 DC Characteristics****Table 4-2. DC Characteristics<sup>(1)</sup>**

Parameter	Symbol	Minimum	Typical	Maximum	Units	Conditions
Supply Voltage	V <sub>CC1</sub>	1.8	—	5.5	V	
Supply Voltage	V <sub>CC2</sub>	2.5	—	5.5	V	
Supply Voltage	V <sub>CC3</sub>	4.5	—	5.5	V	
Supply Current	I <sub>CC1</sub>	—	9.0	10.0	mA	V <sub>CC</sub> = 5.0V at 20 MHz, SO = Open, Read
Supply Current	I <sub>CC2</sub>	—	5.0	7.0	mA	V <sub>CC</sub> = 5.0V at 10 MHz, SO = Open, Read, Write
Supply Current	I <sub>CC3</sub>	—	2.2	3.5	mA	V <sub>CC</sub> = 5.0V at 1 MHz, SO = Open, Read, Write
Standby Current	I <sub>SB1</sub>	—	0.2	3.0	μA	V <sub>CC</sub> = 1.8V, $\overline{CS}$ = V <sub>CC</sub>

**AT25128B/AT25256B****Electrical Characteristics**

.....continued							
Parameter	Symbol	Minimum	Typical	Maximum	Units	Conditions	
Standby Current	$I_{SB2}$	—	0.5	3.0	$\mu\text{A}$	$V_{CC} = 2.5\text{V}$ , $\overline{CS} = V_{CC}$	
Standby Current	$I_{SB3}$	—	2.0	5.0	$\mu\text{A}$	$V_{CC} = 5.0\text{V}$ , $\overline{CS} = V_{CC}$	
Input Leakage	$I_{IL}$	-3.0	—	3.0	$\mu\text{A}$	$V_{IN} = 0\text{V}$ to $V_{CC}$	
Output Leakage	$I_{OL}$	-3.0	—	3.0	$\mu\text{A}$	$V_{IN} = 0\text{V}$ to $V_{CC}$ , $T_{AC} = 0^\circ\text{C}$ to $+70^\circ\text{C}$	
Input Low-Voltage	$V_{IL}^{(2)}$	-1.0	—	$V_{CC} \times 0.3$	V		
Input High-Voltage	$V_{IH}^{(2)}$	$V_{CC} \times 0.7$	—	$V_{CC} + 0.5$	V		
Output Low-Voltage	$V_{OL1}$	—	—	0.4	V	$3.6\text{V} \leq V_{CC} \leq 5.5\text{V}$	$I_{OL} = 3.0\text{ mA}$
Output High-Voltage	$V_{OH1}$	$V_{CC} - 0.8$	—	—	V	$3.6\text{V} \leq V_{CC} \leq 5.5\text{V}$	$I_{OH} = -1.6\text{ mA}$
Output Low-Voltage	$V_{OL2}$	—	—	0.2	V	$1.8\text{V} \leq V_{CC} \leq 3.6\text{V}$	$I_{OL} = 0.15\text{ mA}$
Output High-Voltage	$V_{OH2}$	$V_{CC} - 0.2$	—	—	V	$1.8\text{V} \leq V_{CC} \leq 3.6\text{V}$	$I_{OH} = -100\ \mu\text{A}$

**Note:**

1. Applicable over recommended operating range from:  $T_A = -40^\circ\text{C}$  to  $+85^\circ\text{C}$ ,  $V_{CC} = 1.8\text{V}$  to  $5.5\text{V}$  (unless otherwise noted).
2.  $V_{IL}$  min and  $V_{IH}$  max are reference only and are not tested.

**4.4 AC Characteristics****Table 4-3. AC Characteristics<sup>(1)</sup>**

Parameter	Symbol	Minimum	Maximum	Units	Conditions
SCK Clock Frequency	$f_{SCK}$	0	20	MHz	$V_{CC} = 4.5\text{V}$ to $5.5\text{V}$
		0	10	MHz	$V_{CC} = 2.5\text{V}$ to $5.5\text{V}$
		0	5	MHz	$V_{CC} = 1.8\text{V}$ to $5.5\text{V}$
Input Rise Time	$t_{RI}$	—	2000	ns	$V_{CC} = 4.5\text{V}$ to $5.5\text{V}$
		—	2000	ns	$V_{CC} = 2.5\text{V}$ to $5.5\text{V}$
		—	2000	ns	$V_{CC} = 1.8\text{V}$ to $5.5\text{V}$

**AT25128B/AT25256B****Electrical Characteristics**

.....continued					
Parameter	Symbol	Minimum	Maximum	Units	Conditions
Input Fall Time	$t_{FI}$	—	2000	ns	$V_{CC} = 4.5V$ to $5.5V$
		—	2000	ns	$V_{CC} = 2.5V$ to $5.5V$
		—	2000	ns	$V_{CC} = 1.8V$ to $5.5V$
SCK High Time	$t_{WH}$	20	—	ns	$V_{CC} = 4.5V$ to $5.5V$
		40	—	ns	$V_{CC} = 2.5V$ to $5.5V$
		80	—	ns	$V_{CC} = 1.8V$ to $5.5V$
SCK Low Time	$t_{WL}$	20	—	ns	$V_{CC} = 4.5V$ to $5.5V$
		40	—	ns	$V_{CC} = 2.5V$ to $5.5V$
		80	—	ns	$V_{CC} = 1.8V$ to $5.5V$
$\overline{CS}$ High Time	$t_{CS}$	100	—	ns	$V_{CC} = 4.5V$ to $5.5V$
		100	—	ns	$V_{CC} = 2.5V$ to $5.5V$
		200	—	ns	$V_{CC} = 1.8V$ to $5.5V$
$\overline{CS}$ Setup Time	$t_{CSS}$	100	—	ns	$V_{CC} = 4.5V$ to $5.5V$
		100	—	ns	$V_{CC} = 2.5V$ to $5.5V$
		200	—	ns	$V_{CC} = 1.8V$ to $5.5V$
$\overline{CS}$ Hold Time	$t_{CSH}$	100	—	ns	$V_{CC} = 4.5V$ to $5.5V$
		100	—	ns	$V_{CC} = 2.5V$ to $5.5V$
		200	—	ns	$V_{CC} = 1.8V$ to $5.5V$
Data In Setup Time	$t_{SU}$	5	—	ns	$V_{CC} = 4.5V$ to $5.5V$
		10	—	ns	$V_{CC} = 2.5V$ to $5.5V$
		20	—	ns	$V_{CC} = 1.8V$ to $5.5V$
Data In Hold Time	$t_H$	5	—	ns	$V_{CC} = 4.5V$ to $5.5V$
		10	—	ns	$V_{CC} = 2.5V$ to $5.5V$
		20	—	ns	$V_{CC} = 1.8V$ to $5.5V$
$\overline{HOLD}$ Setup Time	$t_{HD}$	5	—	ns	$V_{CC} = 4.5V$ to $5.5V$
		10	—	ns	$V_{CC} = 2.5V$ to $5.5V$
		20	—	ns	$V_{CC} = 1.8V$ to $5.5V$
$\overline{HOLD}$ Hold Time	$t_{CD}$	5	—	ns	$V_{CC} = 4.5V$ to $5.5V$
		10	—	ns	$V_{CC} = 2.5V$ to $5.5V$
		20	—	ns	$V_{CC} = 1.8V$ to $5.5V$

**AT25128B/AT25256B****Electrical Characteristics**

.....continued

Parameter	Symbol	Minimum	Maximum	Units	Conditions
Output Valid	$t_v$	0	20	ns	$V_{CC} = 4.5V$ to $5.5V$
		0	40	ns	$V_{CC} = 2.5V$ to $5.5V$
		0	80	ns	$V_{CC} = 1.8V$ to $5.5V$
Output Hold Time	$t_{HO}$	0	—	ns	$V_{CC} = 4.5V$ to $5.5V$
		0	—	ns	$V_{CC} = 2.5V$ to $5.5V$
		0	—	ns	$V_{CC} = 1.8V$ to $5.5V$
$\overline{HOLD}$ to Output Low Z	$t_{LZ}$	0	25	ns	$V_{CC} = 4.5V$ to $5.5V$
		0	50	ns	$V_{CC} = 2.5V$ to $5.5V$
		0	100	ns	$V_{CC} = 1.8V$ to $5.5V$
$\overline{HOLD}$ to Output High Z	$t_{HZ}$	—	25	ns	$V_{CC} = 4.5V$ to $5.5V$
		—	50	ns	$V_{CC} = 2.5V$ to $5.5V$
		—	100	ns	$V_{CC} = 1.8V$ to $5.5V$
Output Disable Time	$t_{DIS}$	—	25	ns	$V_{CC} = 4.5V$ to $5.5V$
		—	50	ns	$V_{CC} = 2.5V$ to $5.5V$
		—	100	ns	$V_{CC} = 1.8V$ to $5.5V$
Write Cycle Time	$t_{WC}$	—	5	ms	$V_{CC} = 4.5V$ to $5.5V$
		—	5	ms	$V_{CC} = 2.5V$ to $5.5V$
		—	5	ms	$V_{CC} = 1.8V$ to $5.5V$

**Note:**

1. Applicable over recommended operating range from  $T_A = -40^\circ C$  to  $+85^\circ C$ ,  $V_{CC} =$  As Specified,  $C_L = 1$  TTL Gate and  $30$  pF (unless otherwise noted).

## 4.5 SPI Synchronous Data Timing

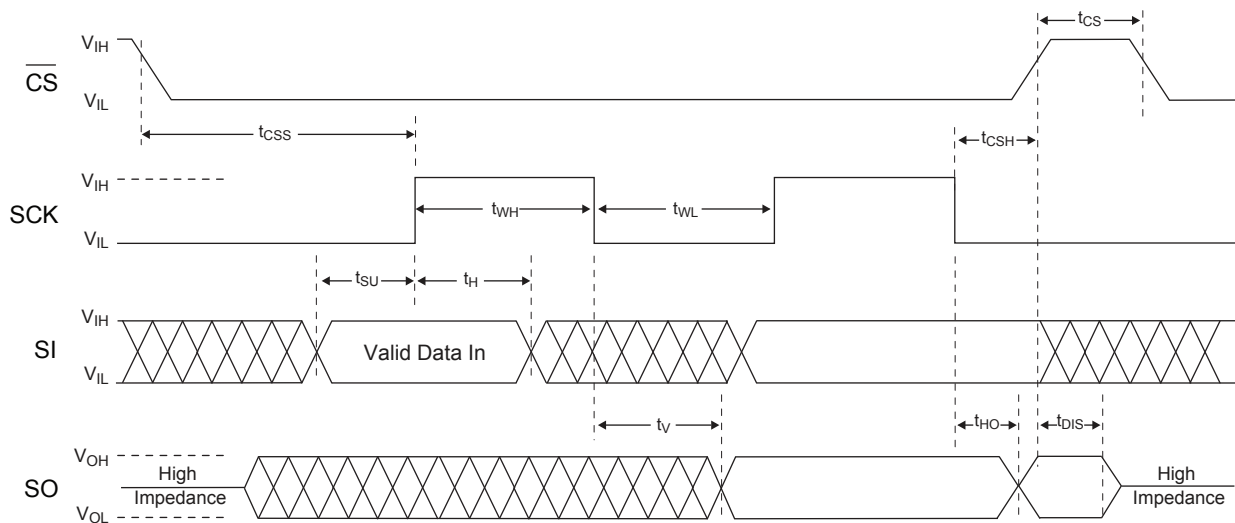

## 4.6 Electrical Specifications

### 4.6.1 Power-Up Requirements and Reset Behavior

During a power-up sequence, the  $V_{CC}$  supplied to the AT25128B/AT25256B should monotonically rise from GND to the minimum  $V_{CC}$  level, as specified in Table 4-1, with a slew rate no faster than 0.1 V/ $\mu$ s.

#### 4.6.1.1 Device Reset

To prevent inadvertent write operations or any other spurious events from occurring during a power-up sequence, the AT25128B/AT25256B includes a Power-on Reset (POR) circuit. Upon power-up, the device will not respond to any instructions until the  $V_{CC}$  level crosses the internal voltage threshold ( $V_{POR}$ ) that brings the device out of Reset and into Standby mode.

The system designer must ensure the instructions are not sent to the device until the  $V_{CC}$  supply has reached a stable value greater than or equal to the minimum  $V_{CC}$  level. Additionally, once the  $V_{CC}$  is greater than or equal to the minimum  $V_{CC}$  level, the bus master must wait at least  $t_{PUP}$  before sending the first instruction to the device. See Table 4-4 for the values associated with these power-up parameters.

**Table 4-4. Power-Up Conditions<sup>(1)</sup>**

Symbol	Parameter	Min.	Max.	Units
$t_{PUP}$	Time required after $V_{CC}$ is stable before the device can accept instructions	100	—	$\mu$ s
$V_{POR}$	Power-on Reset Threshold Voltage	—	1.5	V
$t_{POFF}$	Minimum time at $V_{CC} = 0V$ between power cycles	0.03	—	ms

#### Note:

- These parameters are characterized but they are not 100% tested in production.

If an event occurs in the system where the  $V_{CC}$  level supplied to the AT25128B/AT25256B drops below the maximum  $V_{POR}$  level specified, it is recommended that a full-power cycle sequence be performed by first driving the  $V_{CC}$  pin to GND in less than 1 ms, waiting at least the minimum  $t_{POFF}$  time and then performing a new power-up sequence in compliance with the requirements defined in this section.

**AT25128B/AT25256B****Electrical Characteristics****4.6.2 Pin Capacitance****Table 4-5. Pin Capacitance<sup>(1,2)</sup>**

Symbol	Test Condition	Max.	Units	Conditions
C <sub>OUT</sub>	Output Capacitance (SO)	8	pF	V <sub>OUT</sub> = 0V
C <sub>IN</sub>	Input Capacitance ( $\overline{CS}$ , SCK, SI, $\overline{WP}$ , $\overline{HOLD}$ )	6	pF	V <sub>IN</sub> = 0V

**Note:**

1. This parameter is characterized but is not 100% tested in production.
2. Applicable over recommended operating range from: T<sub>A</sub> = 25°C, f<sub>SCK</sub> = 1.0 MHz, V<sub>CC</sub> = 5.0V (unless otherwise noted).

**4.6.3 EEPROM Cell Performance Characteristics****Table 4-6. EEPROM Cell Performance Characteristics**

Operation	Test Condition	Min.	Max.	Units
Write Endurance <sup>(1)</sup>	T <sub>A</sub> = 25°C, V <sub>CC</sub> = 3.3V, Page Write mode	1,000,000	—	Write Cycles
Data Retention <sup>(1)</sup>	T <sub>A</sub> = 55°C	100	—	Years

**Note:**

1. Performance is determined through characterization and the qualification process.

**4.6.4 Software Reset**

The SPI interface of the AT25128B/AT25256B can be reset by toggling the  $\overline{CS}$  input. If the  $\overline{CS}$  line is already in the active state, it must complete a transition from the inactive state ( $\geq V_{IH}$ ) to the active state ( $\leq V_{IL}$ ) and then back to the inactive state ( $\geq V_{IH}$ ) without sending clocks on the SCK line. Upon completion of this sequence, the device will be ready to receive a new opcode on the SI line.

**4.6.5 Device Default State at Power-Up**

The AT25128B/AT25256B default state upon power-up consists of:

- Standby Power mode
- A high-to-low-level transition on  $\overline{CS}$  is required to enter active state
- Write Enable Latch (WEL) bit in the STATUS register = 0
- $\overline{Ready}/\overline{Busy}$  bit in the STATUS register = 0, indicating the device is ready to accept a new command
- Device is not selected
- Not in Hold condition
- WPEN, BP1 and BP0 bits in the STATUS register are unchanged from their previous state due to the fact that they are nonvolatile values

**4.6.6 Device Default Condition**

The AT25128B/AT25256B is shipped from Microchip to the customer with the EEPROM array set to an all FFh data pattern (logic '1' state). The Write-Protect Enable bit in the STATUS register is set to logic '0' (the ability of the EEPROM array to write is dictated by the values of the Block Write-Protect bits while the STATUS register's ability to write is controlled by the WEL bit). The Block Write Protection bits in the STATUS register are set to logic '0' (no write protection selected).

## 5. Device Operation

The AT25128B/AT25256B is controlled by a set of instructions that are sent from a host controller, commonly referred to as the SPI Master. The SPI Master communicates with the AT25128B/AT25256B via the SPI bus which is comprised of four signal lines: Chip Select ( $\overline{CS}$ ), Serial Data Clock (SCK), Serial Data Input (SI), and Serial Data Output (SO).

The SPI protocol defines a total of four modes of operation (Mode 0, 1, 2 or 3) with each mode differing in respect to the SCK polarity and phase and how the polarity and phase control the flow of data on the SPI bus. The AT25128B/AT25256B supports the two most common modes, SPI Modes 0 and 3. With SPI Modes 0 and 3, data is always latched in on the rising edge of SCK and always output on the falling edge of SCK. The only difference between SPI Modes 0 and 3 is the polarity of the SCK signal when in the inactive state (when the SPI Master is in Standby mode and not transferring any data). SPI Mode 0 is defined as a low SCK while  $\overline{CS}$  is not asserted (at  $V_{CC}$ ) and SPI Mode 3 has SCK high in the inactive state. The SCK Idle state must match when the  $\overline{CS}$  is deasserted both before and after the communication sequence in SPI Mode 0 and 3. The figures in this document depict Mode 0 with a solid line on SCK while  $\overline{CS}$  is inactive and Mode 3 with a dotted line.

**Figure 5-1. SPI Mode 0 and Mode 3**

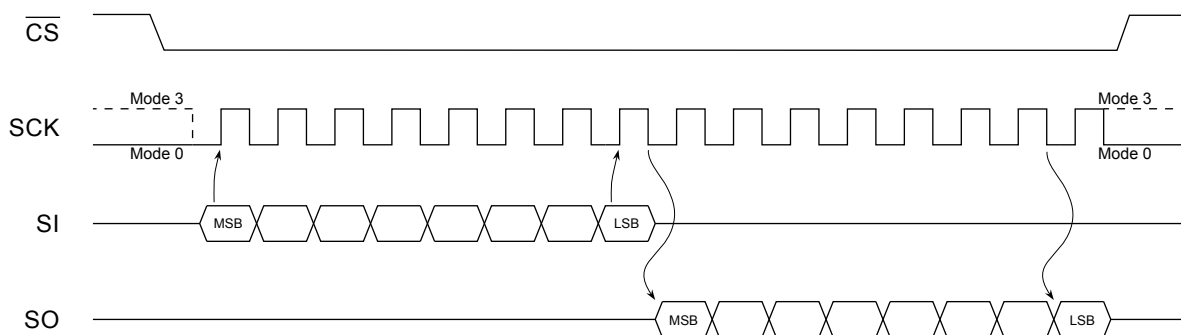

### 5.1 Interfacing the AT25128B/AT25256B on the SPI Bus

Communication to and from the AT25128B/AT25256B must be initiated by the SPI Master device, such as a microcontroller. The SPI Master device must generate the serial clock for the AT25128B/AT25256B on the Serial Data Clock (SCK) pin. The AT25128B/AT25256B always operates as a slave due to the fact that the SCK is always an input.

#### 5.1.1 Selecting the Device

The AT25128B/AT25256B is selected when the Chip Select ( $\overline{CS}$ ) pin is low. When the device is not selected, data will not be accepted via the Serial Data Input (SI) pin, and the Serial Data Output (SO) pin will remain in a high-impedance state.

#### 5.1.2 Sending Data to the Device

The AT25128B/AT25256B uses the SI pin to receive information. All instructions, addresses and data input bytes are clocked into the device with the Most Significant bit (MSb) first. The SI pin samples on the first rising edge of the SCK line after the  $\overline{CS}$  has been asserted.

### 5.1.3 Receiving Data from the Device

Data output from the device is transmitted on the SO pin, with the MSb output first. The SO data is latched on the first falling edge of SCK after the instruction has been clocked into the device, such as the Read from Memory Array (READ) and Read STATUS Register (RDSR) instructions. See [Read Sequence](#) for more details.

## 5.2 Device Opcodes

### 5.2.1 Serial Opcode

After the device is selected by driving  $\overline{CS}$  low, the first byte will be received on the SI pin. This byte contains the opcode that defines the operation to be performed. Refer to [Table 6-1](#) for a list of all opcodes that the AT25128B/AT25256B will respond to.

### 5.2.2 Invalid Opcode

If an invalid opcode is received, no data will be shifted into AT25128B/AT25256B and the SO pin will remain in a high-impedance state until the falling edge of  $\overline{CS}$  is detected again. This will reinitialize the serial communication.

## 5.3 Hold Function

The Suspend Serial Input ( $\overline{HOLD}$ ) pin is used to pause the serial communication with the device without having to stop or reset the clock sequence. The Hold mode, however, does not have an effect on the internal write cycle. Therefore, if a write cycle is in progress, asserting the  $\overline{HOLD}$  pin will not pause the operation and the write cycle will continue to completion.

The Hold mode can only be entered while the  $\overline{CS}$  pin is asserted. The Hold mode is activated by asserting the  $\overline{HOLD}$  pin during the SCK low pulse. If the  $\overline{HOLD}$  pin is asserted during the SCK high pulse, then the Hold mode will not be started until the beginning of the next SCK low pulse. The device will remain in the Hold mode as long as the  $\overline{HOLD}$  pin and  $\overline{CS}$  pin are asserted.

While in Hold mode, the SO pin will be in a high-impedance state. In addition, both the SI pin and the SCK pin will be ignored. The Write-Protect ( $\overline{WP}$ ) pin, however, can still be asserted or deasserted while in the Hold mode.

To end the Hold mode and resume serial communication, the  $\overline{HOLD}$  pin must be deasserted during the SCK low pulse. If the  $\overline{HOLD}$  pin is deasserted during the SCK high pulse, then the Hold mode will not end until the beginning of the next SCK low pulse.

If the  $\overline{CS}$  pin is deasserted while the  $\overline{HOLD}$  pin is still asserted, then any operation that may have been started will be aborted and the device will reset the WEL bit in the STATUS register back to the logic '0' state.

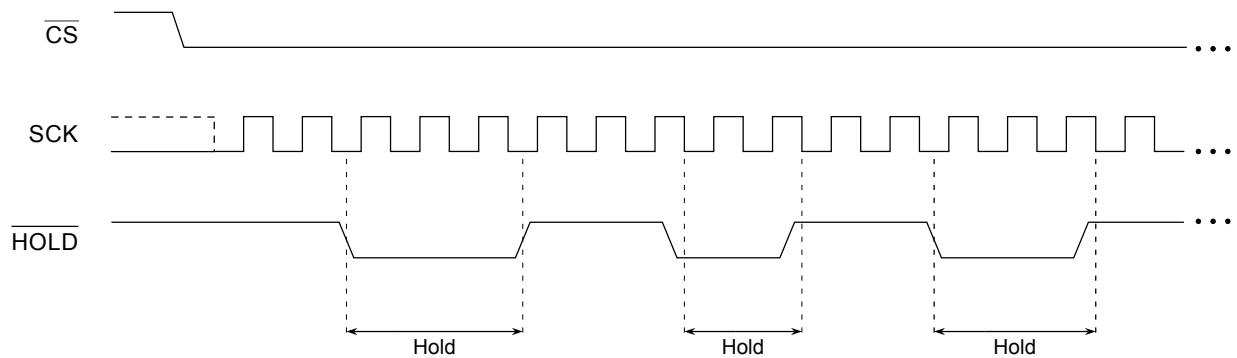
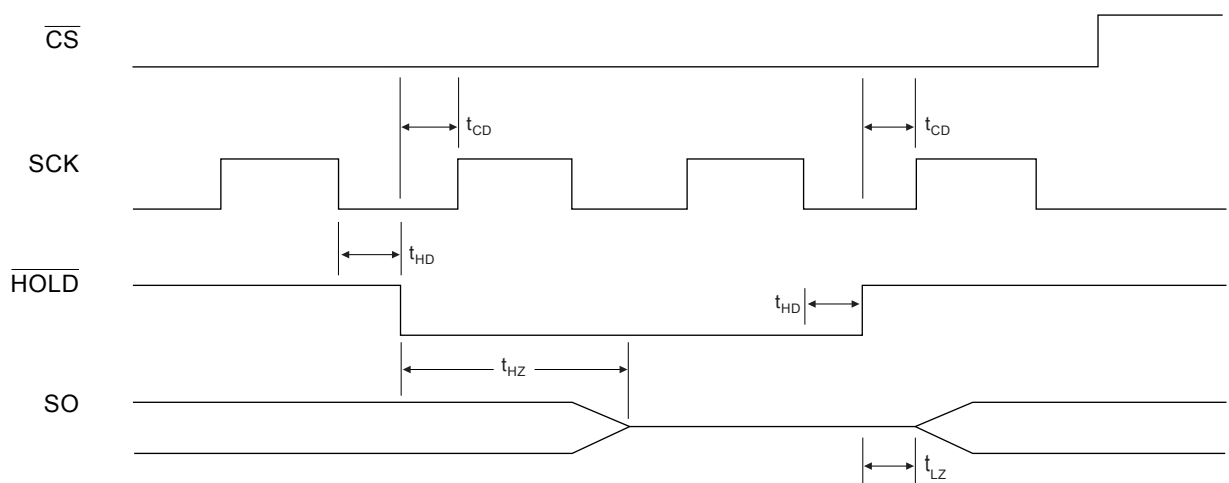
**Figure 5-2. Hold Mode****Figure 5-3. Hold Timing**

## 5.4 Write Protection

The Write-Protect ( $\overline{\text{WP}}$ ) pin will allow normal read and write operations when held high. When the  $\overline{\text{WP}}$  pin is brought low and WPEN bit is a logic '1', all write operations to the STATUS register are inhibited. The  $\overline{\text{WP}}$  pin going low while  $\overline{\text{CS}}$  is still low will interrupt a Write STATUS Register ( $\text{WRSR}$ ). If the internal write cycle has already been initiated,  $\overline{\text{WP}}$  going low will have no effect on any write operation to the STATUS register. The  $\overline{\text{WP}}$  pin function is blocked when the WPEN bit in the STATUS register is a logic '0'. This will allow the user to install the AT25128B/AT25256B device in a system with the  $\overline{\text{WP}}$  pin tied to ground and still be able to write to the STATUS register. All  $\overline{\text{WP}}$  pin functions are enabled when the WPEN bit is set to a logic '1'.

# AT25128B/AT25256B

## Device Commands and Addressing

## 6. Device Commands and Addressing

The AT25128B/AT25256B is designed to interface directly with the synchronous Serial Peripheral Interface (SPI). The AT25128B/AT25256B utilizes an 8-bit instruction register. The list of instructions and their operation codes are contained in [Table 6-1](#). All instructions, addresses and data are transferred with the MSb first and start with a high-to-low  $\overline{CS}$  transition.

**Table 6-1. Instruction Set for the AT25128B/AT25256B**

Instruction Name	Instruction Format	Operates On	Operation Description
WREN	0000 X110	STATUS Register	Set Write Enable Latch (WEL)
WRDI	0000 X100	STATUS Register	Reset Write Enable Latch (WEL)
RDSR	0000 X101	STATUS Register	Read STATUS Register
WRSR	0000 X001	STATUS Register	Write STATUS Register
READ	0000 X011	Memory Array	Read from Memory Array
WRITE	0000 X010	Memory Array	Write to Memory Array

### 6.1 STATUS Register Bit Definition and Function

The AT25128B/AT25256B includes an 8-bit STATUS register. The STATUS register bits modulate various features of the device as shown in [Table 6-2](#) and [Table 6-3](#). These bits can be changed by specific instructions that are detailed in the following sections.

**Table 6-2. STATUS Register Format**

Bit 7	Bit 6	Bit 5	Bit 4	Bit 3	Bit 2	Bit 1	Bit 0
WPEN	X	X	X	BP1	BP0	WEL	$\overline{RDY/BSY}$

**Table 6-3. STATUS Register Bit Definition**

Bit	Name	Type	Description
7	WPEN	R/W	0 See <a href="#">Table 6-5</a> (Factory Default)
			1 See <a href="#">Table 6-5</a> (Factory Default)
6:4	RFU	R	0 Reads as zeros when the device is not in a write cycle
			1 Reads as ones when the device is in a write cycle
3:2	BP1 BP0	R/W	00 No array write protection (Factory Default)
			01 Quarter array write protection (see <a href="#">Table 6-4</a> )
			10 Half array write protection (see <a href="#">Table 6-4</a> )
			11 Entire array write protection (see <a href="#">Table 6-4</a> )
1	WEL	R/W	0 Device is not write enabled (Power-up Default)
			1 Device is write enabled

# AT25128B/AT25256B

## Device Commands and Addressing

.....continued					
Bit	Name	Type	Description		
0	RDY/BSY	Ready/Busy Status	R	0	Device is ready for a new sequence
				1	Device is busy with an internal operation

## 6.2 Read STATUS Register (RDSR)

The Read STATUS Register (RDSR) instruction provides access to the STATUS register. The ready/busy and write enable status of the device can be determined by the RDSR instruction. Similarly, the Block Write Protection (BP<1:0>) bits indicate the extent of memory array protection employed. The STATUS register is read by asserting the  $\overline{CS}$  pin, followed by sending in a 05h opcode on the SI pin. Upon completion of the opcode, the device will return the 8-bit STATUS register value on the SO pin.

Figure 6-1. RDSR Waveform

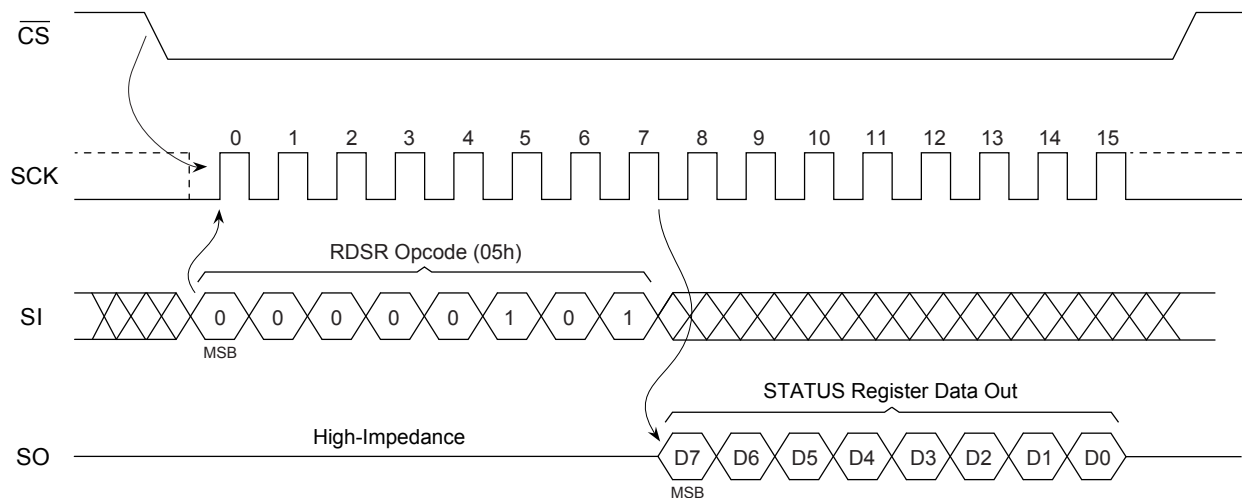

## 6.3 Write Enable (WREN) and Write Disable (WRDI)

Enabling and disabling writing to the STATUS register and EEPROM array is accomplished through the Write Enable (WREN) instruction and the Write Disable (WRDI) instruction. These functions change the status of the WEL bit in the STATUS register.

### 6.3.1 Write Enable Instruction (WREN)

The Write Enable Latch (WEL) bit of the STATUS register must be set to a logic '1' prior to each Write STATUS Register (WRSR) and Write to Memory Array (WRITE) instructions. This is accomplished by sending a WREN (06h) instruction to the AT25128B/AT25256B. First, the  $\overline{CS}$  pin is driven low to select the device and then a WREN instruction is clocked in on the SI pin. Then the  $\overline{CS}$  pin can be driven high and the WEL bit will be updated in the STATUS register to a logic '1'. The device will power-up in the write disable state (WEL = 0).

# AT25128B/AT25256B

## Device Commands and Addressing

**Figure 6-2. WREN Timing**

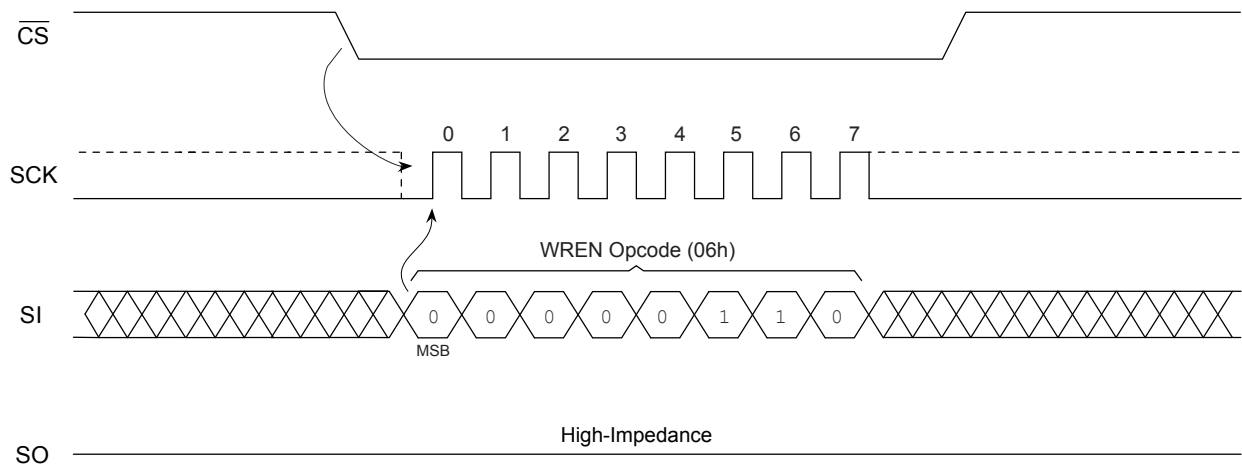

### 6.3.2 Write Disable Instruction ( $\text{WRDI}$ )

To protect the device against inadvertent writes, the Write Disable ( $\text{WRDI}$ ) instruction (opcode 04h) disables all programming modes by setting the WEL bit to a logic '0'. The  $\text{WRDI}$  instruction is independent of the status of the  $\overline{\text{WP}}$  pin.

**Figure 6-3. WRDI Timing**

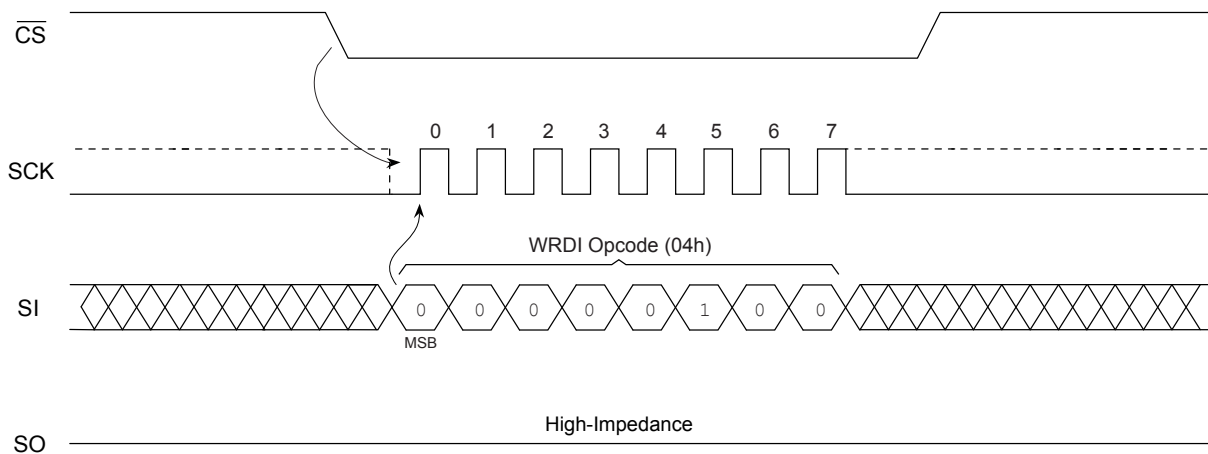

### 6.4 Write STATUS Register ( $\text{WRSR}$ )

The Write STATUS Register ( $\text{WRSR}$ ) instruction enables the SPI Master to change selected bits of the STATUS register. Before a  $\text{WRSR}$  instruction can be initiated, a  $\text{WREN}$  instruction must be executed to set the WEL to logic '1'. Upon completion of a  $\text{WREN}$  instruction, a  $\text{WRSR}$  instruction can be executed.

**Note:** The  $\text{WRSR}$  instruction has no effect on bit 6, bit 5, bit 4, bit 1 and bit 0 of the STATUS register. Only bit 7, bit 3 and bit 2 can be changed via the  $\text{WRSR}$  instruction. These modifiable bits are the Write Protect Enable (WPEN) and Block Protect ( $\text{BP}<1:0>$ ) bits. These three bits are nonvolatile bits that have the same properties and functions as regular EEPROM cells. Their values are retained while power is removed from the device.

# AT25128B/AT25256B

## Device Commands and Addressing

The AT25128B/AT25256B will not respond to commands other than a RDSR after a WRSR instruction until the self-timed internal write cycle has completed. When the write cycle is completed, the WEL bit in the STATUS register is reset to logic '0'.

**Figure 6-4. WRSR Waveform**

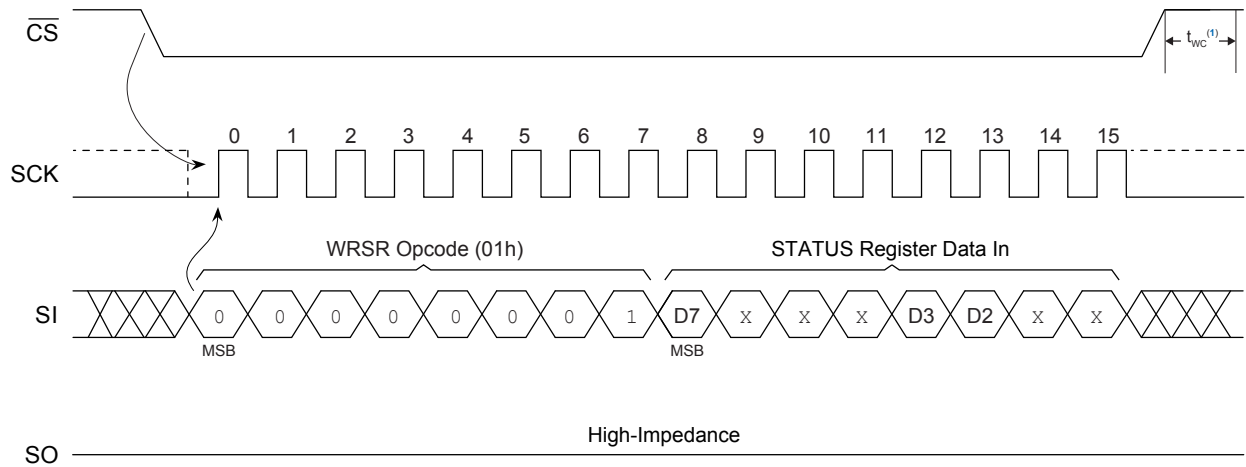

**Note:**

1. This instruction initiates a self-timed internal write cycle ( $t_{wc}$ ) on the rising edge of  $\overline{CS}$  after a valid sequence.

### 6.4.1 Block Write-Protect Function

The WRSR instruction allows the user to select one of four possible combinations as to how the memory array will be inhibited from writing through changing the Block Write-Protect bits (BP<1:0>). The four levels of array protection are:

- None of the memory array is protected.
- Upper quarter ( $1/4$ ) address range is write-protected meaning the highest order address bits are read-only.
- Upper half ( $1/2$ ) address range is write-protected meaning the highest order address bits are read-only.
- All of the memory array is write-protected meaning all address bits are read-only.

The Block Write Protection levels and corresponding STATUS register control bits are shown in [Table 6-4](#).

**Table 6-4. Block Write-Protect Bits**

Level	STATUS Register Bits		Write-Protected/Read-Only Address Range	
	BP1	BP0	AT25128B	AT25256B
0	0	0	None	None
1(1/4)	0	1	3000h-3FFFh	6000h-7FFFh
2(1/2)	1	0	2000h-3FFFh	4000h – 7FFFh
3(All)	1	1	0000h-3FFFh	0000h – 7FFFh

**6.4.2 Write-Protect Enable Function**

The  $\overline{\text{WRSR}}$  instruction also allows the user to enable or disable the Write-Protect ( $\overline{\text{WP}}$ ) pin through the use of the Write-Protect Enable (WPEN) bit. When the WPEN bit is set to logic '0', the ability to write the EEPROM array is dictated by the values of the Block Write-Protect (BP<1:0>) bits. The ability to write the STATUS register is controlled by the WEL bit. When the WPEN bit is set to logic '1', the STATUS register is read-only.

Hardware Write Protection is enabled when both the  $\overline{\text{WP}}$  pin is low and the WPEN bit has been set to a logic '1'. When the device is Hardware Write-Protected, writes to the STATUS register, including the Block Write-Protect, WEL and WPEN bits, and to the sections in the memory array selected by the Block Write-Protect bits are disabled. When Hardware Write Protection is enabled, writes are only allowed to sections of the memory that are not block-protected.

Hardware Write Protection is disabled when either the  $\overline{\text{WP}}$  pin is high or the WPEN bit is a logic '0'. When Hardware Write Protection is disabled, writes are only allowed to sections of the memory that are not block-protected. Refer to [Table 6-5](#) for additional information.

**Note:** When the WPEN bit is Hardware Write-Protected, it cannot be set back to a logic '0' as long as the  $\overline{\text{WP}}$  pin is held low.

**Table 6-5. WPEN Operation**

WPEN	$\overline{\text{WP}}$ Pin	WEL	Protected Blocks	Unprotected Blocks	STATUS Register
0	x	0	Protected	Protected	Protected
0	x	1	Protected	Writable	Writable
1	Low	0	Protected	Protected	Protected
1	Low	1	Protected	Writable	Protected
x	High	0	Protected	Protected	Protected
x	High	1	Protected	Writable	Writable

**AT25128B/AT25256B****Read Sequence****7. Read Sequence**

Reading the AT25128B/AT25256B via the SO pin requires the following sequence. After the  $\overline{\text{CS}}$  line is pulled low to select a device, the `READ` (03h) instruction is transmitted via the SI line followed by the 16-bit address to be read. Refer to [Table 7-1](#) for the address bits for AT25128B/AT25256B.

**Table 7-1. AT25128B/AT25256B Address Bits**

Address	AT25128B	AT25256B
$A_N$	$A_{13}-A_0$	$A_{14}-A_0$
Don't Care Bits	$A_{15}-A_{14}$	$A_{15}$

Upon completion of the 16-bit address, any data on the SI line will be ignored. The data (D7-D0) at the specified address is then shifted out onto the SO line. If only one byte is to be read, the  $\overline{\text{CS}}$  line should be driven high after the data comes out. The read sequence can be continued since the byte address is automatically incremented and data will continue to be shifted out. When the highest-order address bit is reached, the address counter will rollover to the lowest-order address bit allowing the entire memory to be read in one continuous read cycle regardless of the starting address.

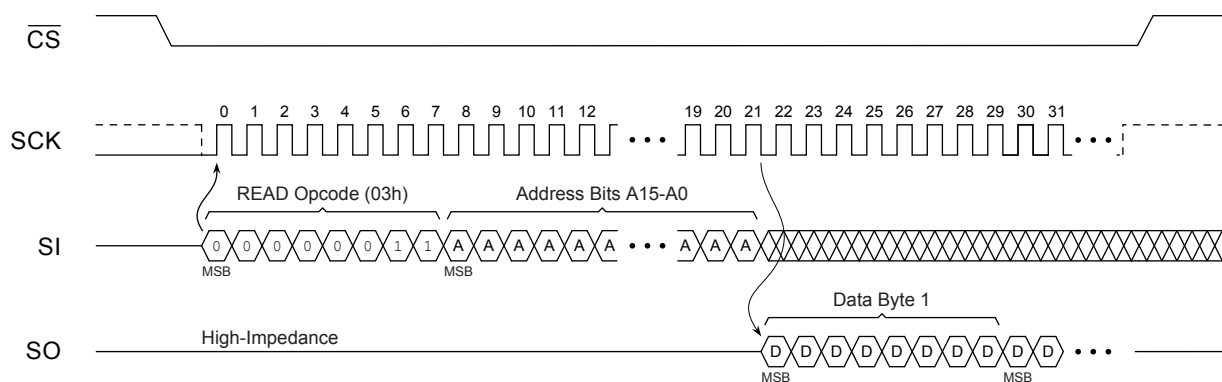
**Figure 7-1. Read Waveform**

## 8. Write Sequence

In order to program the AT25128B/AT25256B, two separate instructions must be executed. First, the device *must be write enabled* via the Write Enable ( $\overline{WREN}$ ) instruction. Then, one of the two possible write sequences described in this section may be executed.

**Note:** If the device is not Write Enabled ( $\overline{WREN}$ ), the device will ignore the  $\overline{WRITE}$  instruction and will return to the standby state when  $\overline{CS}$  is brought high. A new  $\overline{CS}$  assertion is required to re-initiate communication.

The address of the memory location(s) to be programmed must be outside the protected address field location selected by the block write protection level. During an internal write cycle, all commands will be ignored except the  $\overline{RDSR}$  instruction. Refer to [Table 8-1](#) for the address bits for AT25128B/AT25256B.

**Table 8-1. AT25128B/AT25256B Address Bits**

Address	AT25128B	AT25256B
$A_N$	$A_{13}-A_0$	$A_{14}-A_0$
Don't Care Bits	$A_{15}-A_{14}$	$A_{15}$

### 8.1 Byte Write

A Byte Write requires the following sequence and is depicted in [Figure 8-1](#). After the  $\overline{CS}$  line is pulled low to select the device, the  $\overline{WRITE}$  (02h) instruction is transmitted via the SI line followed by the 16-bit address and the data (D7-D0) to be programmed. Programming will start after the  $\overline{CS}$  pin is brought high. The low-to-high transition of the  $\overline{CS}$  pin must occur during the SCK low time (Mode 0) and SCK high time (Mode 3) immediately after clocking in the D0 (LSB) data bit. The AT25128B/AT25256B is automatically returned to the Write Disable state (STATUS register bit WEL = 0) at the completion of a write cycle.

**Figure 8-1. Byte Write**

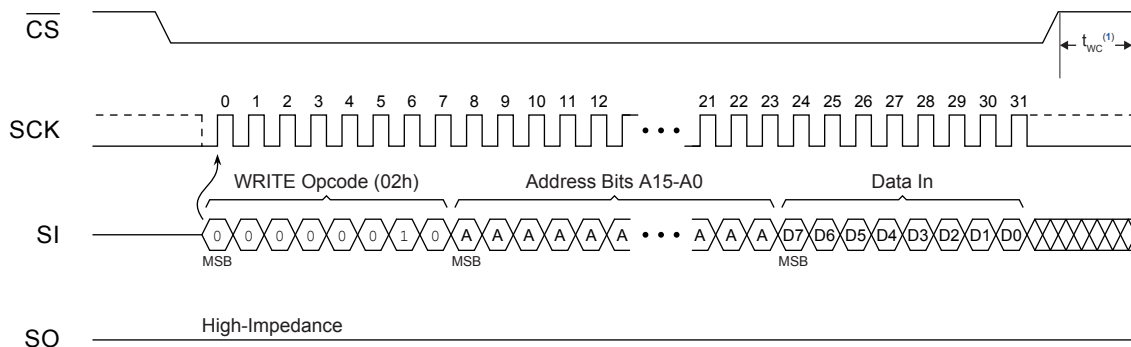

**Note:**

1. This instruction initiates a self-timed internal write cycle ( $t_{wc}$ ) on the rising edge of  $\overline{CS}$  after a valid sequence.

**AT25128B/AT25256B****Write Sequence****8.2 Page Write**

A Page Write sequence allows up to 64 bytes to be written in the same write cycle, provided that all bytes are in the same row of the memory array. Partial Page Writes of less than 64 bytes are allowed. After each byte of data is received, the six lowest order address bits are internally incremented following the receipt of each data byte. The higher order address bits are not incremented and retain the memory array page location. If more bytes of data are transmitted that what will fit to the end of that memory row, the address counter will rollover to the beginning of the same row. Nevertheless, creating a rollover event should be avoided as previously loaded data in the page could become unintentionally altered. The AT25128B/AT25256B is automatically returned to the Write Disable state ( $WEL = 0$ ) at the completion of a write cycle.

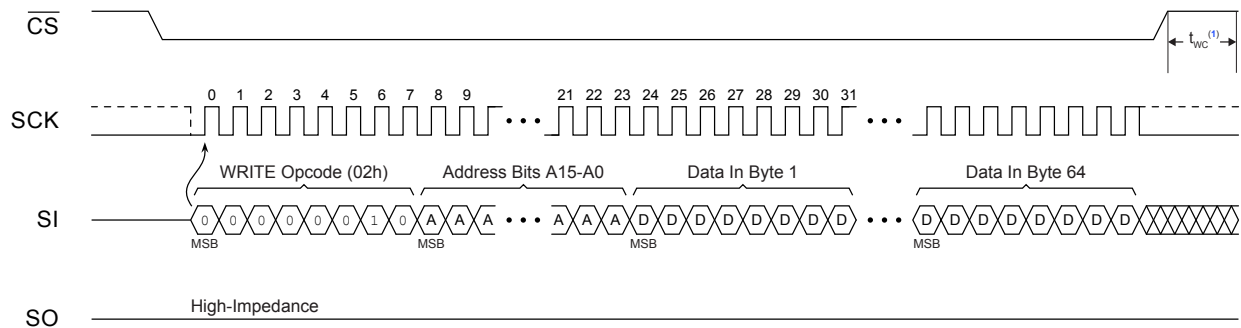
**Figure 8-2. Page Write****Note:**

1. This instruction initiates a self-timed internal write cycle ( $t_{wc}$ ) on the rising edge of  $\overline{CS}$  after a valid sequence.

**8.3 Polling Routine**

A polling routine can be implemented to optimize time-sensitive applications that would not prefer to wait the fixed maximum write cycle time ( $t_{wc}$ ). This method allows the application to know immediately when the write cycle has completed to start a subsequent operation.

Once the internally-timed write cycle has started, a polling routine can be initiated. This involves repeatedly sending Read STATUS Register ( $RDSR$ ) instruction to determine if the device has completed its self-timed internal write cycle. If the  $\overline{RDY}/BSY$  bit (bit 0 of STATUS register) = 1, the write cycle is still in progress. If bit 0 = 0, the write cycle has ended. If the  $\overline{RDY}/BSY$  bit = 1, repeated  $RDSR$  commands can be executed until the  $\overline{RDY}/BSY$  bit = 0, signaling that the device is ready to execute a new instruction. Only the Read STATUS Register ( $RDSR$ ) instruction is enabled during the write cycle.

# AT25128B/AT25256B

## Write Sequence

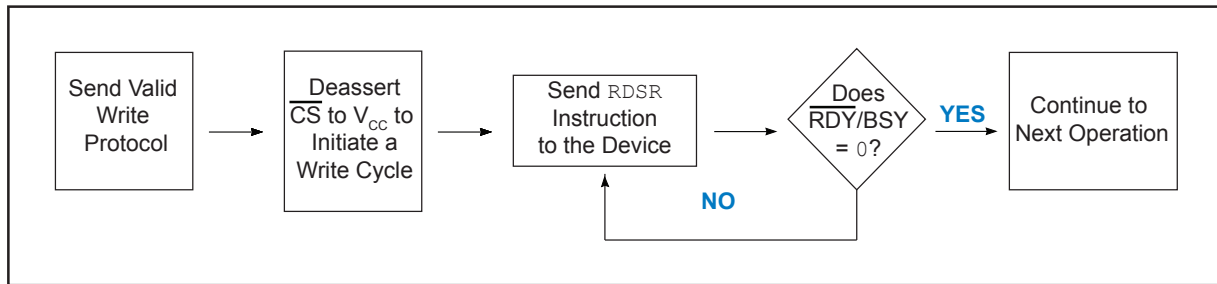
**Figure 8-3. Polling Flowchart**



# AT25128B/AT25256B

## Packaging Information

### 9. Packaging Information

#### 9.1 Package Marking Information

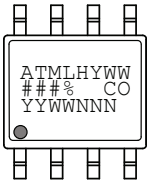
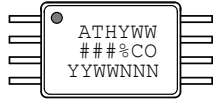
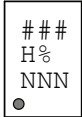
### AT25128B and AT25256B: Package Marking Information

<p>8-Lead SOIC</p> 	<p>8-Lead TSSOP</p> 
<p>8-Pad UDFN</p> <p>2.0 x 3.0 mm Body</p> 	<p>8-Ball VFBGA</p> <p>2.35 x 3.73 mm Body</p> 

Note 1: ● designates pin 1  
 Note 2: Package drawings are not to scale

<b>Catalog Number Truncation</b>			
AT25128B	Truncation Code ###: 5DB		
AT25256B	Truncation Code ###: 5EB		
<b>Date Codes</b>			<b>Voltages</b>
YY = Year	Y = Year	WW = Work Week of Assembly	% = Minimum Voltage
16: 2016    20: 2020	6: 2016    0: 2020	02: Week 2	L: 1.8V min
17: 2017    21: 2021	7: 2017    1: 2021	04: Week 4	
18: 2018    22: 2022	8: 2018    2: 2022	...	
19: 2019    23: 2023	9: 2019    3: 2023	52: Week 52	
<b>Country of Origin</b>		<b>Device Grade</b>	<b>Atmel Truncation</b>
CO = Country of Origin		H or U: Industrial Grade	AT: Atmel ATM: Atmel ATML: Atmel
<b>Lot Number or Trace Code</b>			
NNN = Alphanumeric Trace Code (2 Characters for Small Packages)			

# AT25128B/AT25256B

## Packaging Information

### 8-Lead Plastic Small Outline (SN) - Narrow, 3.90 mm (.150 In.) Body [SOIC]

**Note:** For the most current package drawings, please see the Microchip Packaging Specification located at <http://www.microchip.com/packaging>

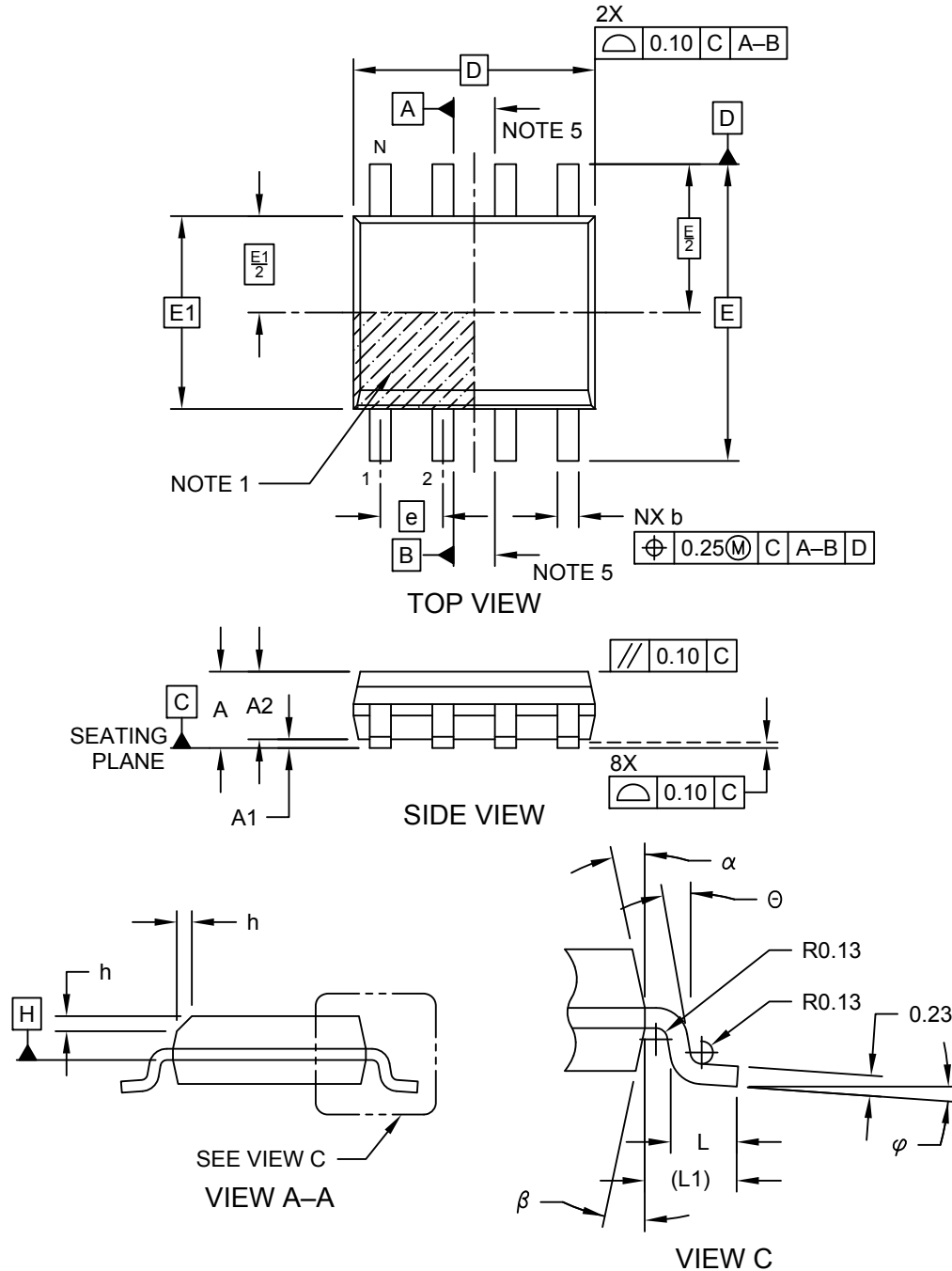

Microchip Technology Drawing No. C04-057-SN Rev E Sheet 1 of 2

**AT25128B/AT25256B****Packaging Information****8-Lead Plastic Small Outline (SN) - Narrow, 3.90 mm (.150 In.) Body [SOIC]**

**Note:** For the most current package drawings, please see the Microchip Packaging Specification located at <http://www.microchip.com/packaging>

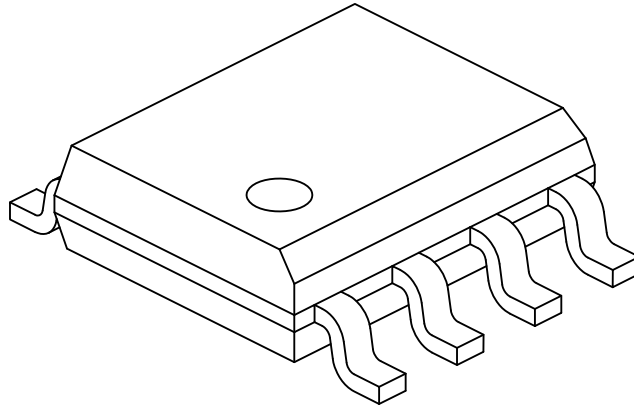

Dimension Limits	Units	MILLIMETERS		
		MIN	NOM	MAX
Number of Pins	N	8		
Pitch	e	1.27 BSC		
Overall Height	A	-	-	1.75
Molded Package Thickness	A2	1.25	-	-
Standoff §	A1	0.10	-	0.25
Overall Width	E	6.00 BSC		
Molded Package Width	E1	3.90 BSC		
Overall Length	D	4.90 BSC		
Chamfer (Optional)	h	0.25	-	0.50
Foot Length	L	0.40	-	1.27
Footprint	L1	1.04 REF		
Foot Angle	φ	0°	-	8°
Lead Thickness	c	0.17	-	0.25
Lead Width	b	0.31	-	0.51
Mold Draft Angle Top	α	5°	-	15°
Mold Draft Angle Bottom	β	5°	-	15°

**Notes:**

- Pin 1 visual index feature may vary, but must be located within the hatched area.
- § Significant Characteristic
- Dimensions D and E1 do not include mold flash or protrusions. Mold flash or protrusions shall not exceed 0.15mm per side.
- Dimensioning and tolerancing per ASME Y14.5M  
BSC: Basic Dimension. Theoretically exact value shown without tolerances.  
REF: Reference Dimension, usually without tolerance, for information purposes only.
- Datums A & B to be determined at Datum H.

Microchip Technology Drawing No. C04-057-SN Rev E Sheet 2 of 2

# AT25128B/AT25256B

## Packaging Information

### 8-Lead Plastic Small Outline (SN) - Narrow, 3.90 mm Body [SOIC]

**Note:** For the most current package drawings, please see the Microchip Packaging Specification located at <http://www.microchip.com/packaging>

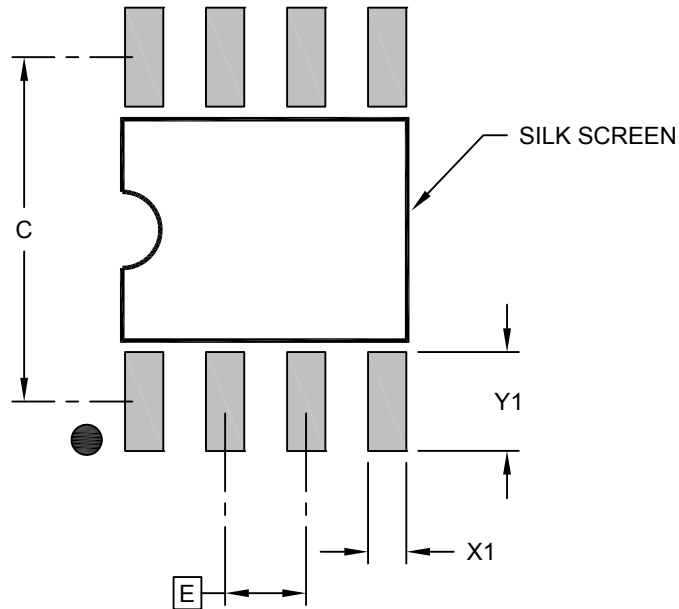

### RECOMMENDED LAND PATTERN

Dimension Limits	Units	MILLIMETERS		
		MIN	NOM	MAX
Contact Pitch	E	1.27 BSC		
Contact Pad Spacing	C		5.40	
Contact Pad Width (X8)	X1			0.60
Contact Pad Length (X8)	Y1			1.55

**Notes:**

1. Dimensioning and tolerancing per ASME Y14.5M  
BSC: Basic Dimension. Theoretically exact value shown without tolerances.

Microchip Technology Drawing C04-2057-SN Rev E

# AT25128B/AT25256B

## Packaging Information

### 8-Lead Plastic Thin Shrink Small Outline (ST) – 4.4 mm Body [TSSOP]

**Note:** For the most current package drawings, please see the Microchip Packaging Specification located at <http://www.microchip.com/packaging>

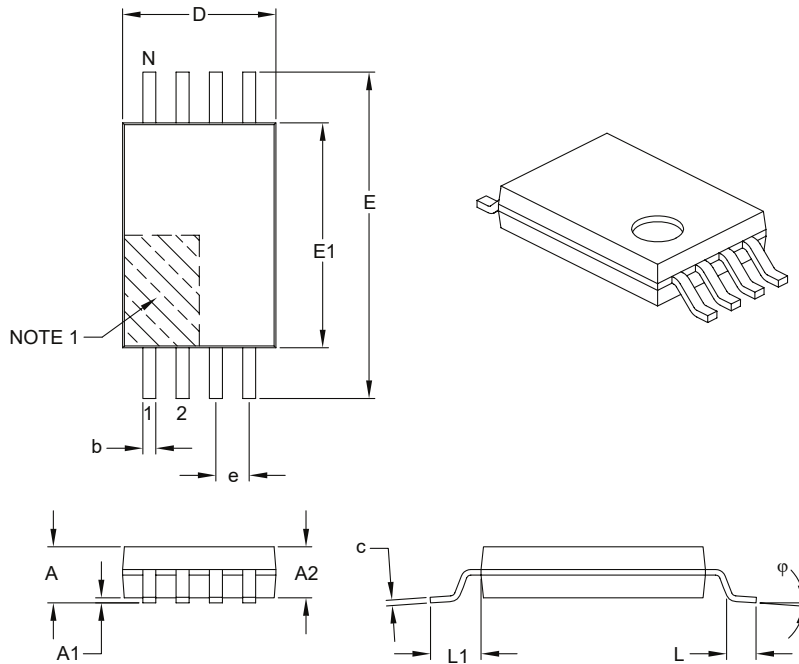

Dimension Limits	Units	MILLIMETERS		
		MIN	NOM	MAX
Number of Pins	N	8		
Pitch	e	0.65 BSC		
Overall Height	A	–	–	1.20
Molded Package Thickness	A2	0.80	1.00	1.05
Standoff	A1	0.05	–	0.15
Overall Width	E	6.40 BSC		
Molded Package Width	E1	4.30	4.40	4.50
Molded Package Length	D	2.90	3.00	3.10
Foot Length	L	0.45	0.60	0.75
Footprint	L1	1.00 REF		
Foot Angle	$\phi$	0°	–	8°
Lead Thickness	c	0.09	–	0.20
Lead Width	b	0.19	–	0.30

**Notes:**

- Pin 1 visual index feature may vary, but must be located within the hatched area.
- Dimensions D and E1 do not include mold flash or protrusions. Mold flash or protrusions shall not exceed 0.15 mm per side.
- Dimensioning and tolerancing per ASME Y14.5M.

BSC: Basic Dimension. Theoretically exact value shown without tolerances.

REF: Reference Dimension, usually without tolerance, for information purposes only.

Microchip Technology Drawing C04-086B

# AT25128B/AT25256B

## Packaging Information

### 8-Lead Plastic Thin Shrink Small Outline (ST) - 4.4 mm Body [TSSOP]

**Note:** For the most current package drawings, please see the Microchip Packaging Specification located at <http://www.microchip.com/packaging>

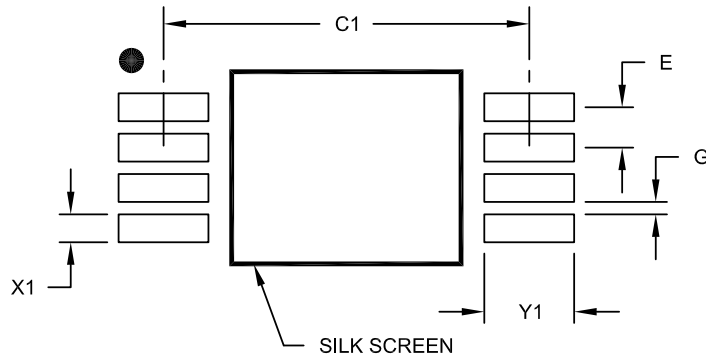

### RECOMMENDED LAND PATTERN

Dimension Limits	Units	MILLIMETERS		
		MIN	NOM	MAX
Contact Pitch	E		0.65 BSC	
Contact Pad Spacing	C1		5.90	
Contact Pad Width (X8)	X1			0.45
Contact Pad Length (X8)	Y1			1.45
Distance Between Pads	G	0.20		

**Notes:**

1. Dimensioning and tolerancing per ASME Y14.5M

BSC; Basic Dimension. Theoretically exact value shown without tolerances.

Microchip Technology Drawing No. C04-2086A

# AT25128B/AT25256B

## Packaging Information

### 8-Lead Ultra Thin Plastic Dual Flat, No Lead Package (Q4B) - 2x3 mm Body [UDFN] Atmel Legacy YNZ Package

**Note:** For the most current package drawings, please see the Microchip Packaging Specification located at <http://www.microchip.com/packaging>

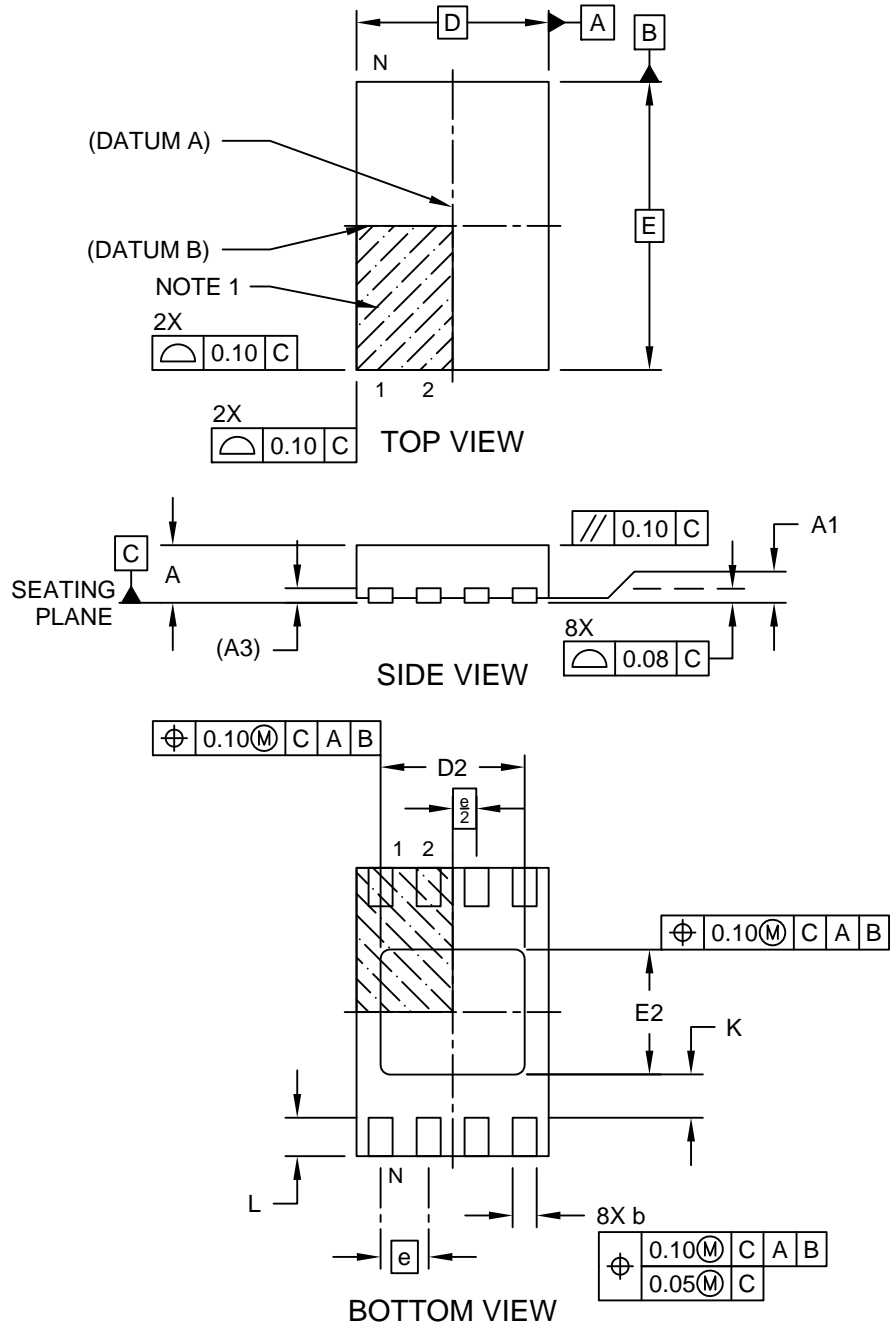

Microchip Technology Drawing C04-21355-Q4B Rev A Sheet 1 of 2

**AT25128B/AT25256B****Packaging Information****8-Lead Ultra Thin Plastic Dual Flat, No Lead Package (Q4B) - 2x3 mm Body [UDFN]  
Atmel Legacy YNZ Package**

**Note:** For the most current package drawings, please see the Microchip Packaging Specification located at <http://www.microchip.com/packaging>

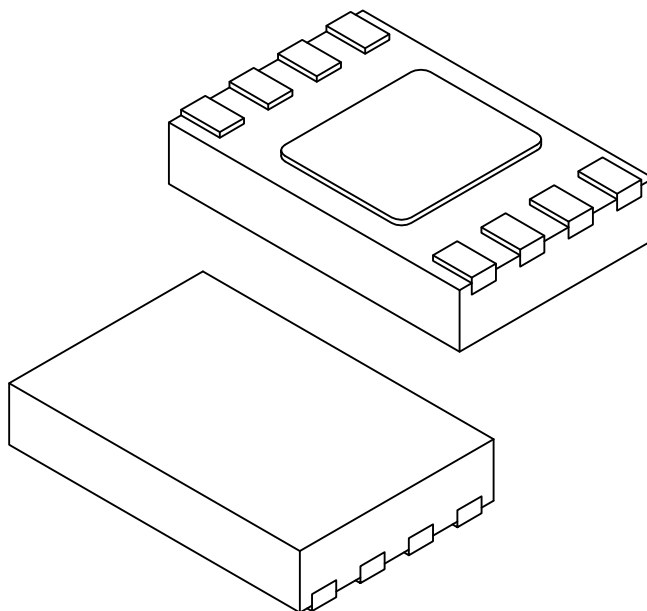

Dimension Limits	Units	MILLIMETERS		
		MIN	NOM	MAX
Number of Terminals	N	8		
Pitch	e	0.50 BSC		
Overall Height	A	0.50	0.55	0.60
Standoff	A1	0.00	0.02	0.05
Terminal Thickness	A3	0.152 REF		
Overall Length	D	2.00 BSC		
Exposed Pad Length	D2	1.40	1.50	1.60
Overall Width	E	3.00 BSC		
Exposed Pad Width	E2	1.20	1.30	1.40
Terminal Width	b	0.18	0.25	0.30
Terminal Length	L	0.35	0.40	0.45
Terminal-to-Exposed-Pad	K	0.20	-	-

**Notes:**

1. Pin 1 visual index feature may vary, but must be located within the hatched area.
2. Package is saw singulated
3. Dimensioning and tolerancing per ASME Y14.5M

BSC: Basic Dimension. Theoretically exact value shown without tolerances.

REF: Reference Dimension, usually without tolerance, for information purposes only.

Microchip Technology Drawing C04-21355-Q4B Rev A Sheet 2 of 2

**AT25128B/AT25256B****Packaging Information****8-Lead Ultra Thin Plastic Dual Flat, No Lead Package (Q4B) - 2x3 mm Body [UDFN]  
Atmel Legacy YNZ Package**

**Note:** For the most current package drawings, please see the Microchip Packaging Specification located at <http://www.microchip.com/packaging>

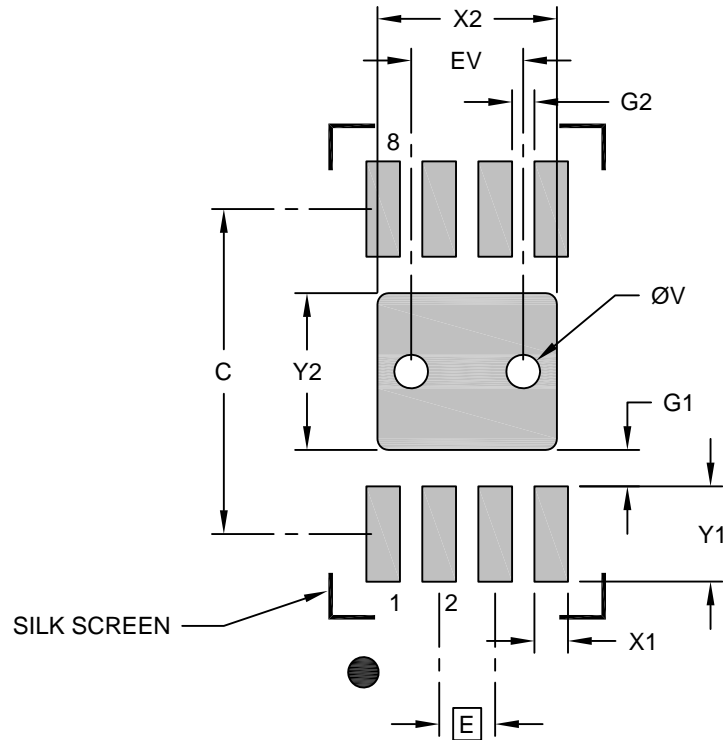
**RECOMMENDED LAND PATTERN**

Dimension Limits	Units	MILLIMETERS		
		MIN	NOM	MAX
Contact Pitch	E	0.50 BSC		
Optional Center Pad Width	X2			1.60
Optional Center Pad Length	Y2			1.40
Contact Pad Spacing	C		2.90	
Contact Pad Width (X8)	X1			0.30
Contact Pad Length (X8)	Y1			0.85
Contact Pad to Center Pad (X8)	G1	0.20		
Contact Pad to Contact Pad (X6)	G2	0.33		
Thermal Via Diameter	V		0.30	
Thermal Via Pitch	EV		1.00	

**Notes:**

- Dimensioning and tolerancing per ASME Y14.5M  
BSC: Basic Dimension. Theoretically exact value shown without tolerances.
- For best soldering results, thermal vias, if used, should be filled or tented to avoid solder loss during reflow process

Microchip Technology Drawing C04-21355-Q4B Rev A

# AT25128B/AT25256B

## Packaging Information

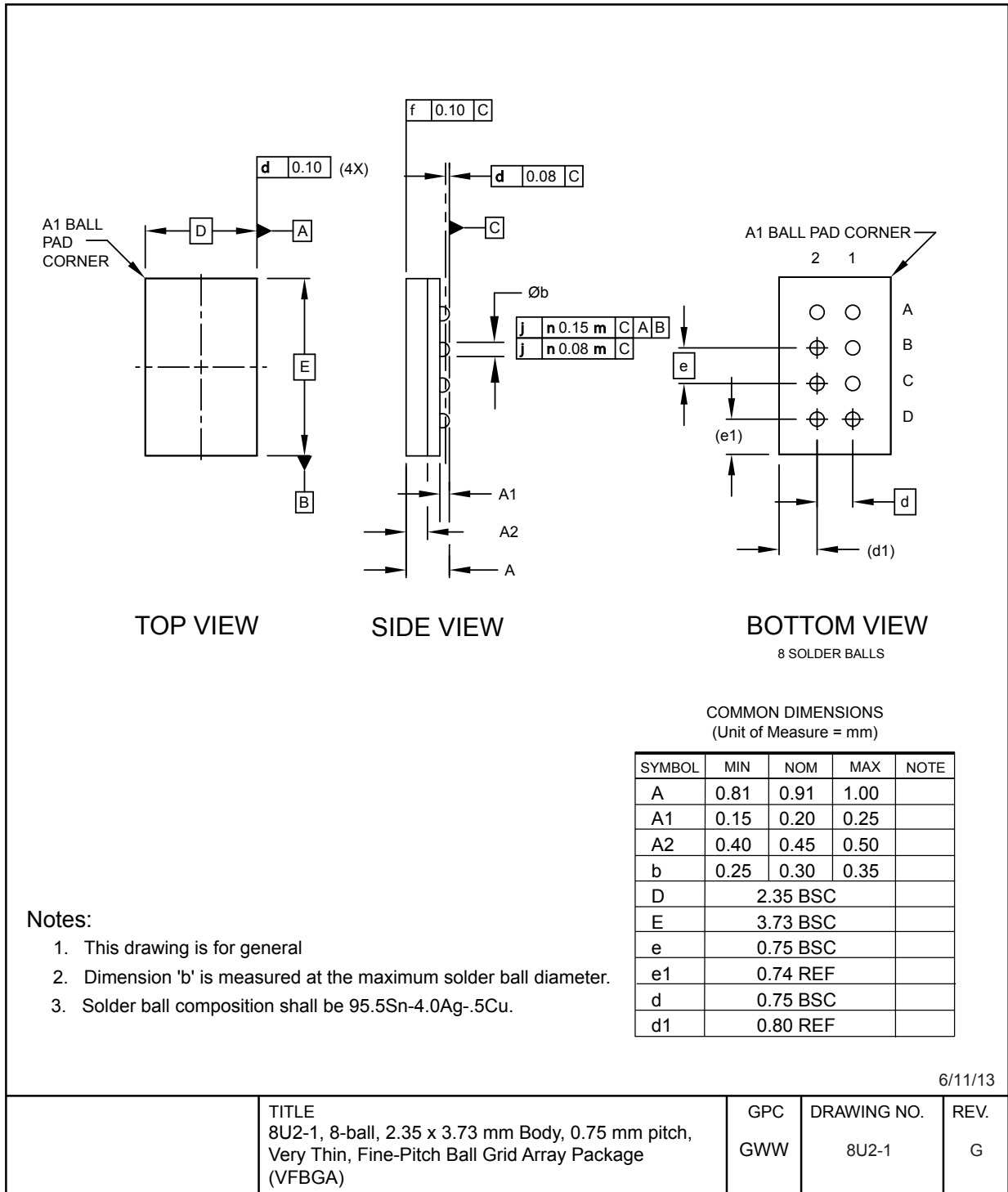

**Note:** For the most current package drawings, please see the Microchip Packaging Specification located at <http://www.microchip.com/packaging>.

## 10. Revision History

### **Revision A (May 2019)**

Updated to the Microchip template. Microchip DS20006193 replaces Atmel document 8698. Updated Part Marking Information. Added ESD rating. Removed lead finish designation. Added POR recommendations section. Updated trace code format in package markings. Updated section content throughout for clarification. Updated the SOIC, TSSOP, and UDFN package drawings to the Microchip equivalents.

### **Atmel Document 8698 Revision E (January 2015)**

Added the UDFN Expanded Quantity Option and ordering information. Updated the 8MA2 package outline drawing.

### **Atmel Document 8698 Revision D (July 2014)**

Updated part markings, 8MA2 and 8U2-1 package drawings, package 8A2 to 8X, template, logos, and disclaimer page. No change to functional specification.

### **Atmel Document 8698 Revision C (August 2011)**

Updated 8A2 and 8S1 package drawings. Corrected page 13, Device Density from 156K to 256K. Corrected page 9, table headings. Corrected cross references on pages 7, 8, and 9.

### **Atmel Document 8698 Revision B (March 2010)**

Updated Catalog Numbering Scheme. Updated Ordering Information and package types.

### **Atmel Document 8698 Revision A (December 2009)**

Initial document release.

## The Microchip Web Site

---

Microchip provides online support via our web site at <http://www.microchip.com/>. This web site is used as a means to make files and information easily available to customers. Accessible by using your favorite Internet browser, the web site contains the following information:

- **Product Support** – Data sheets and errata, application notes and sample programs, design resources, user's guides and hardware support documents, latest software releases and archived software
- **General Technical Support** – Frequently Asked Questions (FAQ), technical support requests, online discussion groups, Microchip consultant program member listing
- **Business of Microchip** – Product selector and ordering guides, latest Microchip press releases, listing of seminars and events, listings of Microchip sales offices, distributors and factory representatives

## Customer Change Notification Service

---

Microchip's customer notification service helps keep customers current on Microchip products. Subscribers will receive e-mail notification whenever there are changes, updates, revisions or errata related to a specified product family or development tool of interest.

To register, access the Microchip web site at <http://www.microchip.com/>. Under "Support", click on "Customer Change Notification" and follow the registration instructions.

## Customer Support

---

Users of Microchip products can receive assistance through several channels:

- Distributor or Representative
- Local Sales Office
- Field Application Engineer (FAE)
- Technical Support

Customers should contact their distributor, representative or Field Application Engineer (FAE) for support. Local sales offices are also available to help customers. A listing of sales offices and locations is included in the back of this document.

Technical support is available through the web site at: <http://www.microchip.com/support>

## Product Identification System

To order or obtain information, e.g., on pricing or delivery, refer to the factory or the listed sales office.

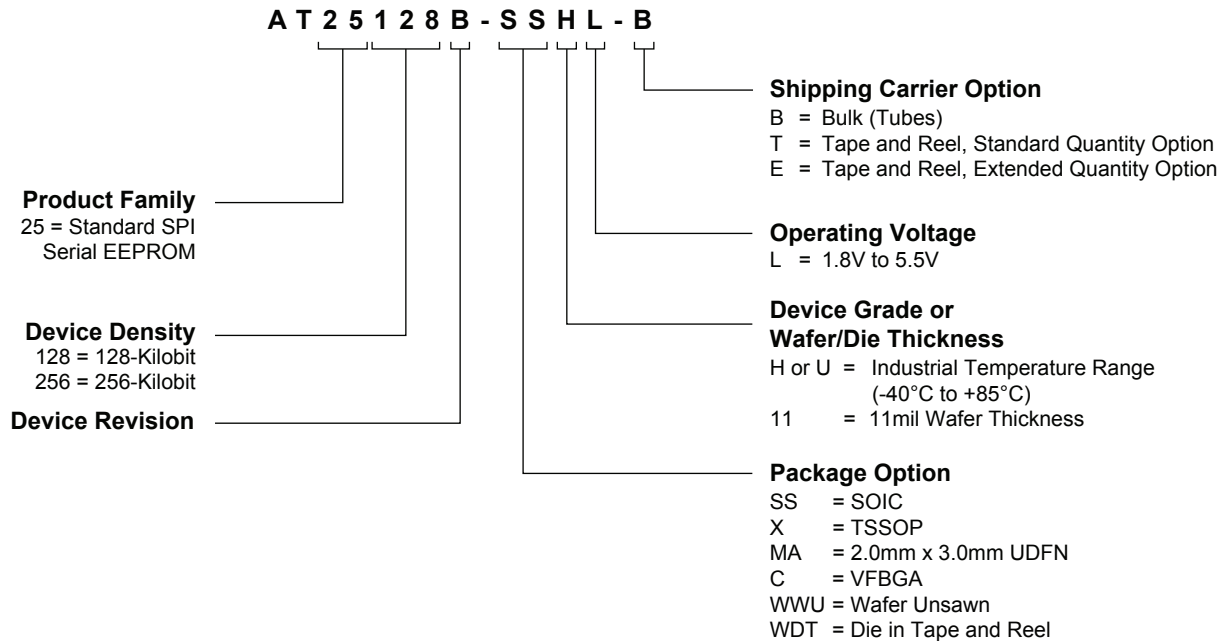

Examples:

Device	Package	Package Drawing Code	Package Option	Shipping Carrier Option	Device Grade
AT25128B-SSHL-B	SOIC	SN	SS	Bulk (Tubes)	Industrial Temperature (-40°C to 85°C)
AT25128B-SSHL-T	SOIC	SN	SS	Tape and Reel	
AT25256B-SSHL-T	SOIC	SN	SS	Tape and Reel	
AT25128B-XHL-B	TSSOP	ST	X	Bulk (Tubes)	
AT25256B-XHL-T	TSSOP	ST	X	Tape and Reel	
AT25128B-MAHL-E	UDFN	Q4B	MA	Tape and Reel	
AT25256B-MAHL-T	UDFN	Q4B	MA	Tape and Reel	
AT25256B-MAHL-E	UDFN	Q4B	MA	Tape and Reel	
AT25256B-CUL-T	VFBGA	8U2-1	C	Tape and Reel	

## Microchip Devices Code Protection Feature

Note the following details of the code protection feature on Microchip devices:

- Microchip products meet the specification contained in their particular Microchip Data Sheet.

- Microchip believes that its family of products is one of the most secure families of its kind on the market today, when used in the intended manner and under normal conditions.
- There are dishonest and possibly illegal methods used to breach the code protection feature. All of these methods, to our knowledge, require using the Microchip products in a manner outside the operating specifications contained in Microchip's Data Sheets. Most likely, the person doing so is engaged in theft of intellectual property.
- Microchip is willing to work with the customer who is concerned about the integrity of their code.
- Neither Microchip nor any other semiconductor manufacturer can guarantee the security of their code. Code protection does not mean that we are guaranteeing the product as "unbreakable."

Code protection is constantly evolving. We at Microchip are committed to continuously improving the code protection features of our products. Attempts to break Microchip's code protection feature may be a violation of the Digital Millennium Copyright Act. If such acts allow unauthorized access to your software or other copyrighted work, you may have a right to sue for relief under that Act.

## Legal Notice

Information contained in this publication regarding device applications and the like is provided only for your convenience and may be superseded by updates. It is your responsibility to ensure that your application meets with your specifications. MICROCHIP MAKES NO REPRESENTATIONS OR WARRANTIES OF ANY KIND WHETHER EXPRESS OR IMPLIED, WRITTEN OR ORAL, STATUTORY OR OTHERWISE, RELATED TO THE INFORMATION, INCLUDING BUT NOT LIMITED TO ITS CONDITION, QUALITY, PERFORMANCE, MERCHANTABILITY OR FITNESS FOR PURPOSE. Microchip disclaims all liability arising from this information and its use. Use of Microchip devices in life support and/or safety applications is entirely at the buyer's risk, and the buyer agrees to defend, indemnify and hold harmless Microchip from any and all damages, claims, suits, or expenses resulting from such use. No licenses are conveyed, implicitly or otherwise, under any Microchip intellectual property rights unless otherwise stated.

## Trademarks

The Microchip name and logo, the Microchip logo, AnyRate, AVR, AVR logo, AVR Freaks, BitCloud, chipKIT, chipKIT logo, CryptoMemory, CryptoRF, dsPIC, FlashFlex, flexPWR, Helder, JukeBlox, KeeLoq, Klear, LANCheck, LINK MD, maXStylus, maXTouch, MediaLB, megaAVR, MOST, MOST logo, MPLAB, OptoLyzer, PIC, picoPower, PICSTART, PIC32 logo, Prochip Designer, QTouch, SAM-BA, SpyNIC, SST, SST Logo, SuperFlash, tinyAVR, UNI/O, and XMEGA are registered trademarks of Microchip Technology Incorporated in the U.S.A. and other countries.

ClockWorks, The Embedded Control Solutions Company, EtherSynch, Hyper Speed Control, HyperLight Load, IntelliMOS, mTouch, Precision Edge, and Quiet-Wire are registered trademarks of Microchip Technology Incorporated in the U.S.A.

Adjacent Key Suppression, AKS, Analog-for-the-Digital Age, Any Capacitor, AnyIn, AnyOut, BodyCom, CodeGuard, CryptoAuthentication, CryptoAutomotive, CryptoCompanion, CryptoController, dsPICDEM, dsPICDEM.net, Dynamic Average Matching, DAM, ECAN, EtherGREEN, In-Circuit Serial Programming, ICSP, INICnet, Inter-Chip Connectivity, JitterBlocker, KlearNet, KlearNet logo, memBrain, Mindi, MiWi, motorBench, MPASM, MPF, MPLAB Certified logo, MPLIB, MPLINK, MultiTRAK, NetDetach, Omniscient Code Generation, PICDEM, PICDEM.net, PICKit, PICtail, PowerSmart, PureSilicon, QMatrix, REAL ICE, Ripple Blocker, SAM-ICE, Serial Quad I/O, SMART-I.S., SQL, SuperSwitcher, SuperSwitcher II, Total

Endurance, TSHARC, USBCheck, VariSense, ViewSpan, WiperLock, Wireless DNA, and ZENA are trademarks of Microchip Technology Incorporated in the U.S.A. and other countries.

SQTP is a service mark of Microchip Technology Incorporated in the U.S.A.

Silicon Storage Technology is a registered trademark of Microchip Technology Inc. in other countries.

GestIC is a registered trademark of Microchip Technology Germany II GmbH & Co. KG, a subsidiary of Microchip Technology Inc., in other countries.

All other trademarks mentioned herein are property of their respective companies.

© 2019, Microchip Technology Incorporated, Printed in the U.S.A., All Rights Reserved.

ISBN: 978-1-5224-4457-2

## **Quality Management System Certified by DNV**

---

### **ISO/TS 16949**

Microchip received ISO/TS-16949:2009 certification for its worldwide headquarters, design and wafer fabrication facilities in Chandler and Tempe, Arizona; Gresham, Oregon and design centers in California and India. The Company's quality system processes and procedures are for its PIC<sup>®</sup> MCUs and dsPIC<sup>®</sup> DSCs, KEELOQ<sup>®</sup> code hopping devices, Serial EEPROMs, microperipherals, nonvolatile memory and analog products. In addition, Microchip's quality system for the design and manufacture of development systems is ISO 9001:2000 certified.



## Worldwide Sales and Service

AMERICAS	ASIA/PACIFIC	ASIA/PACIFIC	EUROPE
<b>Corporate Office</b> 2355 West Chandler Blvd. Chandler, AZ 85224-6199 Tel: 480-792-7200 Fax: 480-792-7277 Technical Support: <a href="http://www.microchip.com/support">http://www.microchip.com/support</a> Web Address: <a href="http://www.microchip.com">www.microchip.com</a>	<b>Australia - Sydney</b> Tel: 61-2-9868-6733 <b>China - Beijing</b> Tel: 86-10-8569-7000 <b>China - Chengdu</b> Tel: 86-28-8665-5511 <b>China - Chongqing</b> Tel: 86-23-8980-9588 <b>China - Dongguan</b> Tel: 86-769-8702-9880 <b>China - Guangzhou</b> Tel: 86-20-8755-8029 <b>China - Hangzhou</b> Tel: 86-571-8792-8115 <b>China - Hong Kong SAR</b> Tel: 852-2943-5100 <b>China - Nanjing</b> Tel: 86-25-8473-2460 <b>China - Qingdao</b> Tel: 86-532-8502-7355 <b>China - Shanghai</b> Tel: 86-21-3326-8000 <b>China - Shenyang</b> Tel: 86-24-2334-2829 <b>China - Shenzhen</b> Tel: 86-755-8864-2200 <b>China - Suzhou</b> Tel: 86-186-6233-1526 <b>China - Wuhan</b> Tel: 86-27-5980-5300 <b>China - Xian</b> Tel: 86-29-8833-7252 <b>China - Xiamen</b> Tel: 86-592-2388138 <b>China - Zhuhai</b> Tel: 86-756-3210040	<b>India - Bangalore</b> Tel: 91-80-3090-4444 <b>India - New Delhi</b> Tel: 91-11-4160-8631 <b>India - Pune</b> Tel: 91-20-4121-0141 <b>Japan - Osaka</b> Tel: 81-6-6152-7160 <b>Japan - Tokyo</b> Tel: 81-3-6880-3770 <b>Korea - Daegu</b> Tel: 82-53-744-4301 <b>Korea - Seoul</b> Tel: 82-2-554-7200 <b>Malaysia - Kuala Lumpur</b> Tel: 60-3-7651-7906 <b>Malaysia - Penang</b> Tel: 60-4-227-8870 <b>Philippines - Manila</b> Tel: 63-2-634-9065 <b>Singapore</b> Tel: 65-6334-8870 <b>Taiwan - Hsin Chu</b> Tel: 886-3-577-8366 <b>Taiwan - Kaohsiung</b> Tel: 886-7-213-7830 <b>Taiwan - Taipei</b> Tel: 886-2-2508-8600 <b>Thailand - Bangkok</b> Tel: 66-2-694-1351 <b>Vietnam - Ho Chi Minh</b> Tel: 84-28-5448-2100	<b>Austria - Wels</b> Tel: 43-7242-2244-39 Fax: 43-7242-2244-393 <b>Denmark - Copenhagen</b> Tel: 45-4450-2828 Fax: 45-4485-2829 <b>Finland - Espoo</b> Tel: 358-9-4520-820 <b>France - Paris</b> Tel: 33-1-69-53-63-20 Fax: 33-1-69-30-90-79 <b>Germany - Garching</b> Tel: 49-8931-9700 <b>Germany - Haan</b> Tel: 49-2129-3766400 <b>Germany - Heilbronn</b> Tel: 49-7131-67-3636 <b>Germany - Karlsruhe</b> Tel: 49-721-625370 <b>Germany - Munich</b> Tel: 49-89-627-144-0 Fax: 49-89-627-144-44 <b>Germany - Rosenheim</b> Tel: 49-8031-354-560 <b>Israel - Ra'anana</b> Tel: 972-9-744-7705 <b>Italy - Milan</b> Tel: 39-0331-742611 Fax: 39-0331-466781 <b>Italy - Padova</b> Tel: 39-049-7625286 <b>Netherlands - Druenen</b> Tel: 31-416-690399 Fax: 31-416-690340 <b>Norway - Trondheim</b> Tel: 47-72884388 <b>Poland - Warsaw</b> Tel: 48-22-3325737 <b>Romania - Bucharest</b> Tel: 40-21-407-87-50 <b>Spain - Madrid</b> Tel: 34-91-708-08-90 Fax: 34-91-708-08-91 <b>Sweden - Gothenberg</b> Tel: 46-31-704-60-40 <b>Sweden - Stockholm</b> Tel: 46-8-5090-4654 <b>UK - Wokingham</b> Tel: 44-118-921-5800 Fax: 44-118-921-5820

## OUR CERTIFICATE

DiGi provide top-quality products and perfect service for customer worldwide through standardization, technological innovation and continuous improvement. DiGi through third-party certification, we stricly control the quality of products and services. Welcome your RFQ to

Email: [Info@DiGi-Electronics.com](mailto:Info@DiGi-Electronics.com)

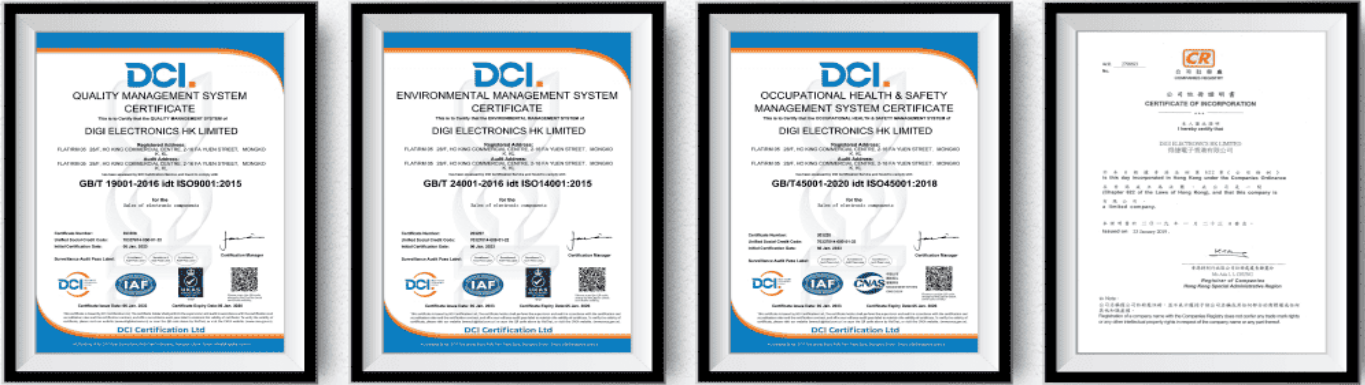

Tel: +00 852-30501935

RFQ Email: [Info@DiGi-Electronics.com](mailto:Info@DiGi-Electronics.com)

DiGi is a global authorized distributor of electronic components.