

# MCP3201-BI/P Datasheet



<https://www.DiGi-Electronics.com>

DiGi Electronics Part Number	MCP3201-BI/P-DG
Manufacturer	<a href="#">Microchip Technology</a>
Manufacturer Product Number	MCP3201-BI/P
Description	IC ADC 12BIT SAR 8DIP
Detailed Description	12 Bit Analog to Digital Converter 1 Input 1 SAR 8-P DIP

This model MCP3201-BI/P is available at DiGi Electronics.

DiGi Electronics offers a global database of semiconductor and electronic component datasheets.

We welcome your inquiries regarding pricing, lead time, or other product-related questions.

 [Request a Quote](#)

 [Datasheet Search](#)



Tel: +00 852-30501935

RFQ Email: [Info@DiGi-Electronics.com](mailto:Info@DiGi-Electronics.com)

DiGi is a global authorized distributor of electronic components.

## Purchase and inquiry

Manufacturer Product Number:

MCP3201-BI/P

Series:

-

Number of Bits:

12

Number of Inputs:

1

Data Interface:

SPI

Ratio - S/H:ADC:

1:1

Architecture:

SAR

Voltage - Supply, Analog:

2.7V ~ 5.5V

Features:

-

Package / Case:

8-DIP (0.300", 7.62mm)

Mounting Type:

Through Hole

Manufacturer:

Microchip Technology

Product Status:

Active

Sampling Rate (Per Second):

100k

Input Type:

Pseudo-Differential

Configuration:

S/H-ADC

Number of A/D Converters:

1

Reference Type:

External

Voltage - Supply, Digital:

2.7V ~ 5.5V

Operating Temperature:

-40°C ~ 85°C

Supplier Device Package:

8-PDIP

Base Product Number:

MCP3201

## Environmental & Export classification

RoHS Status:

ROHS3 Compliant

REACH Status:

REACH Unaffected

HTSUS:

8542.39.0001

Moisture Sensitivity Level (MSL):

1 (Unlimited)

ECCN:

EAR99



# MCP3201

## 2.7V 12-Bit A/D Converter with SPI Serial Interface

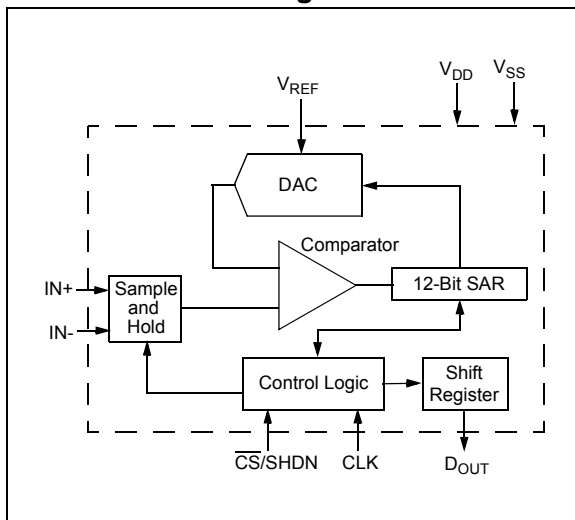
### Features

- 12-Bit Resolution
- $\pm 1$  LSB max DNL
- $\pm 1$  LSB max INL (MCP3201-B)
- $\pm 2$  LSB max INL (MCP3201-C)
- On-chip Sample and Hold
- SPI Serial Interface (modes 0,0 and 1,1)
- Single Supply Operation: 2.7V - 5.5V
- 100 ksp/s Maximum Sampling Rate at  $V_{DD} = 5V$
- 50 ksp/s Maximum Sampling Rate at  $V_{DD} = 2.7V$
- Low-Power CMOS Technology
- 500 nA Typical Standby Current, 2  $\mu A$  Maximum
- 400  $\mu A$  Maximum Active Current at 5V
- Industrial Temp Range:  $-40^{\circ}C$  to  $+85^{\circ}C$
- 8-pin MSOP, PDIP, SOIC and TSSOP Packages

### Applications

- Sensor Interface
- Process Control
- Data Acquisition
- Battery Operated Systems

### Functional Block Diagram

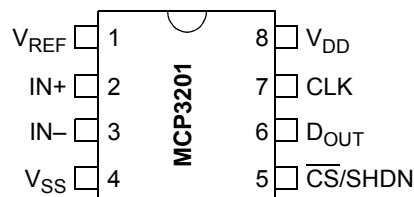


### Description

The Microchip Technology Inc. MCP3201 device is a successive approximation 12-bit Analog-to-Digital (A/D) Converter with on-board sample and hold circuitry. The device provides a single pseudo-differential input. Differential Nonlinearity (DNL) is specified at  $\pm 1$  LSB, and Integral Nonlinearity (INL) is offered in  $\pm 1$  LSB (MCP3201-B) and  $\pm 2$  LSB (MCP3201-C) versions. Communication with the device is done using a simple serial interface compatible with the SPI protocol. The device is capable of sample rates of up to 100 ksp/s at a clock rate of 1.6 MHz. The MCP3201 device operates over a broad voltage range (2.7V-5.5V). Low-current design permits operation with typical standby and active currents of only 500 nA and 300  $\mu A$ , respectively. The device is offered in 8-pin MSOP, PDIP, TSSOP and 150 mil SOIC packages.

### Package Types

#### MSOP, PDIP, SOIC, TSSOP



# MCP3201

---

NOTES:

## 1.0 ELECTRICAL CHARACTERISTICS

### 1.1 Maximum Ratings†

$V_{DD}$ .....	7.0V
All inputs and outputs w.r.t. $V_{SS}$ .....	-0.6V to $V_{DD} + 0.6V$
Storage temperature .....	-65°C to +150°C
Ambient temp. with power applied .....	-65°C to +125°C
ESD protection on all pins (HBM) .....	> 4 kV

†**Notice:** Stresses above those listed under “Maximum ratings” may cause permanent damage to the device. This is a stress rating only and functional operation of the device at those or any other conditions above those indicated in the operational listings of this specification is not implied. Exposure to maximum rating conditions for extended periods may affect device reliability.

## ELECTRICAL CHARACTERISTICS

**Electrical Specifications:** All parameters apply at  $V_{DD} = 5V$ ,  $V_{SS} = 0V$ ,  $V_{REF} = 5V$ ,  $T_A = -40^{\circ}C$  to  $+85^{\circ}C$ ,  $f_{SAMPLE} = 100$  ksps, and  $f_{CLK} = 16 * f_{SAMPLE}$ , unless otherwise noted.

Parameter	Sym	Min	Typ	Max	Units	Conditions
<b>Conversion Rate:</b>						
Conversion Time	$t_{CONV}$	—	—	12	clock cycles	
Analog Input Sample Time	$t_{SAMPLE}$	1.5			clock cycles	
Throughput Rate	$f_{SAMPLE}$	—	—	100 50	ksps ksps	$V_{DD} = V_{REF} = 5V$ $V_{DD} = V_{REF} = 2.7V$
<b>DC Accuracy:</b>						
Resolution		12			bits	
Integral Nonlinearity	INL	—	$\pm 0.75$ $\pm 1$	$\pm 1$ $\pm 2$	LSB LSB	MCP3201-B MCP3201-C
Differential Nonlinearity	DNL	—	$\pm 0.5$	$\pm 1$	LSB	No missing codes over temperature
Offset Error		—	$\pm 1.25$	$\pm 3$	LSB	
Gain Error		—	$\pm 1.25$	$\pm 5$	LSB	
<b>Dynamic Performance:</b>						
Total Harmonic Distortion	THD	—	-82	—	dB	$V_{IN} = 0.1V$ to $4.9V@1$ kHz
Signal to Noise and Distortion (SINAD)	SINAD	—	72	—	dB	$V_{IN} = 0.1V$ to $4.9V@1$ kHz
Spurious Free Dynamic Range	SFDR	—	86	—	dB	$V_{IN} = 0.1V$ to $4.9V@1$ kHz
<b>Reference Input:</b>						
Voltage Range		0.25	—	$V_{DD}$	V	<b>Note 2</b>
Current Drain		—	100 .001	150 3	$\mu A$ $\mu A$	$CS = V_{DD} = 5V$
<b>Analog Inputs:</b>						
Input Voltage Range (IN+)	IN+	IN-	—	$V_{REF} + IN-$	V	
Input Voltage Range (IN-)	IN-	$V_{SS} - 100$		$V_{SS} + 100$	mV	
Leakage Current		—	0.001	$\pm 1$	$\mu A$	
Switch Resistance	$R_{SS}$	—	1K	—	W	See <a href="#">Figure 4-1</a>
Sample Capacitor	$C_{SAMPLE}$	—	20	—	pF	See <a href="#">Figure 4-1</a>
<b>Digital Input/Output:</b>						
Data Coding Format		Straight Binary				
High Level Input Voltage	$V_{IH}$	$0.7 V_{DD}$	—	—	V	
Low Level Input Voltage	$V_{IL}$	—	—	$0.3 V_{DD}$	V	

**Note 1:** This parameter is established by characterization and not 100% tested.

**2:** See graph that relates linearity performance to  $V_{REF}$  level.

**3:** Because the sample cap will eventually lose charge, effective clock rates below 10 kHz can affect linearity performance, especially at elevated temperatures. See [Section 6.2 “Maintaining Minimum Clock Speed”](#) for more information.

# MCP3201

## ELECTRICAL CHARACTERISTICS (CONTINUED)

<b>Electrical Specifications:</b> All parameters apply at $V_{DD} = 5V$ , $V_{SS} = 0V$ , $V_{REF} = 5V$ , $T_A = -40^{\circ}C$ to $+85^{\circ}C$ , $f_{SAMPLE} = 100$ kpsps, and $f_{CLK} = 16 * f_{SAMPLE}$ , unless otherwise noted.						
Parameter	Sym	Min	Typ	Max	Units	Conditions
High Level Output Voltage	$V_{OH}$	4.1	—	—	V	$I_{OH} = -1$ mA, $V_{DD} = 4.5V$
Low Level Output Voltage	$V_{OL}$	—	—	0.4	V	$I_{OL} = 1$ mA, $V_{DD} = 4.5V$
Input Leakage Current	$I_{LI}$	-10	—	10	$\mu A$	$V_{IN} = V_{SS}$ or $V_{DD}$
Output Leakage Current	$I_{LO}$	-10	—	10	$\mu A$	$V_{OUT} = V_{SS}$ or $V_{DD}$
Pin Capacitance (all inputs/outputs)	$C_{IN}$ , $C_{OUT}$	—	—	10	pF	$V_{DD} = 5.0V$ ( <b>Note 1</b> ) $T_A = +25^{\circ}C$ , $f = 1$ MHz
<b>Timing Parameters:</b>						
Clock Frequency	$f_{CLK}$	—	—	1.6 0.8	MHz MHz	$V_{DD} = 5V$ ( <b>Note 3</b> ) $V_{DD} = 2.7V$ ( <b>Note 3</b> )
Clock High Time	$t_{HI}$	312	—	—	ns	
Clock Low Time	$t_{LO}$	312	—	—	ns	
$\overline{CS}$ Fall To First Rising CLK Edge	$t_{SUCS}$	100	—	—	ns	
CLK Fall To Output Data Valid	$t_{DO}$	—	—	200	ns	See Test Circuits, <a href="#">Figure 1-2</a>
CLK Fall To Output Enable	$t_{EN}$	—	—	200	ns	See Test Circuits, <a href="#">Figure 1-2</a>
$\overline{CS}$ Rise To Output Disable	$t_{DIS}$	—	—	100	ns	See Test Circuits, <a href="#">Figure 1-2</a> ( <b>Note 1</b> )
$\overline{CS}$ Disable Time	$t_{CSH}$	625	—	—	ns	
$D_{OUT}$ Rise Time	$t_R$	—	—	100	ns	See Test Circuits, <a href="#">Figure 1-2</a> ( <b>Note 1</b> )
$D_{OUT}$ Fall Time	$t_F$	—	—	100	ns	See Test Circuits, <a href="#">Figure 1-2</a> ( <b>Note 1</b> )
<b>Power Requirements:</b>						
Operating Voltage	$V_{DD}$	2.7	—	5.5	V	
Operating Current	$I_{DD}$	—	300 210	400 —	$\mu A$ $\mu A$	$V_{DD} = 5.0V$ , $D_{OUT}$ unloaded $V_{DD} = 2.7V$ , $D_{OUT}$ unloaded
Standby Current	$I_{DDS}$	—	0.5	2	$\mu A$	$\overline{CS} = V_{DD} = 5.0V$

**Note 1:** This parameter is established by characterization and not 100% tested.

**2:** See graph that relates linearity performance to  $V_{REF}$  level.

**3:** Because the sample cap will eventually lose charge, effective clock rates below 10 kHz can affect linearity performance, especially at elevated temperatures. See [Section 6.2 "Maintaining Minimum Clock Speed"](#) for more information.

## TEMPERATURE CHARACTERISTICS

<b>Electrical Specifications:</b> Unless otherwise indicated, $V_{DD} = +2.7V$ to $+5.5V$ , $V_{SS} = GND$ .						
Parameters	Sym	Min	Typ	Max	Units	Conditions
<b>Temperature Ranges</b>						
Specified Temperature Range	$T_A$	-40	—	+85	$^{\circ}C$	
Operating Temperature Range	$T_A$	-40	—	+85	$^{\circ}C$	
Storage Temperature Range	$T_A$	-65	—	+150	$^{\circ}C$	
<b>Thermal Package Resistances</b>						
Thermal Resistance, 8L-MSOP	$\theta_{JA}$	—	211	—	$^{\circ}C/W$	
Thermal Resistance, 8L-PDIP	$\theta_{JA}$	—	89.5	—	$^{\circ}C/W$	
Thermal Resistance, 8L-SOIC	$\theta_{JA}$	—	149.5	—	$^{\circ}C/W$	
Thermal Resistance, 8L-TSSOP	$\theta_{JA}$	—	139	—	$^{\circ}C/W$	

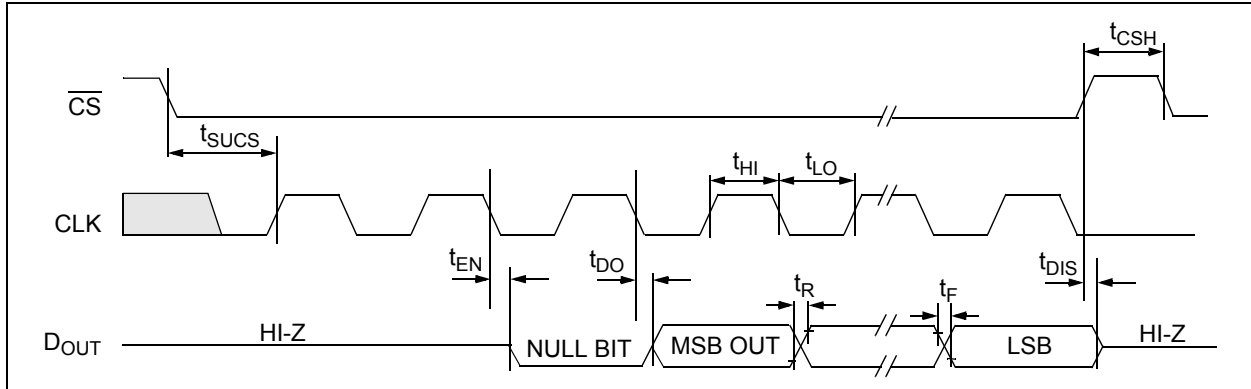


FIGURE 1-1: Serial Timing.

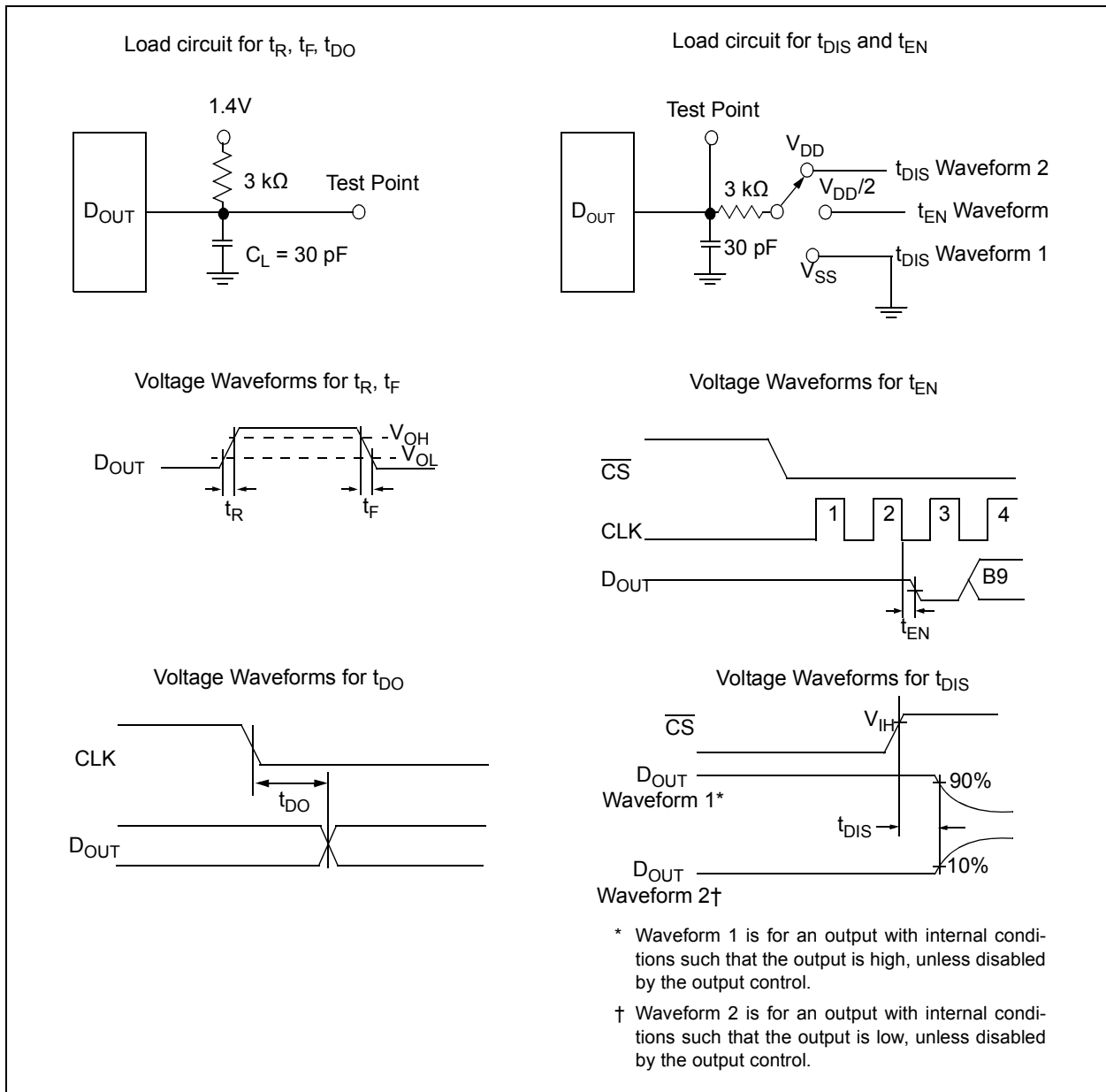


FIGURE 1-2: Test Circuits.

# MCP3201

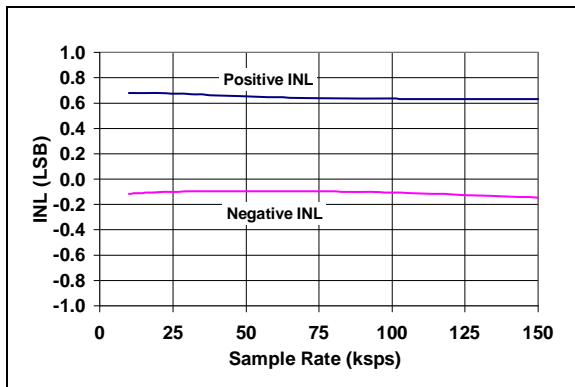
---

NOTES:

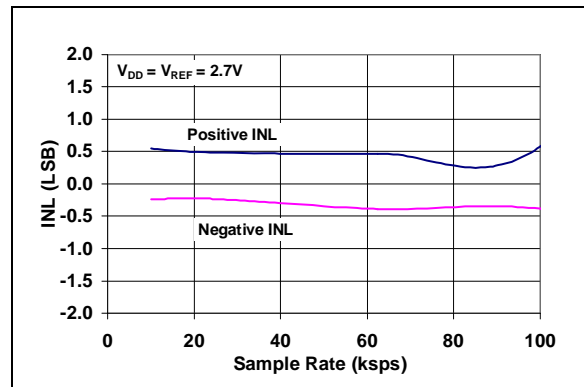
## 2.0 TYPICAL PERFORMANCE CHARACTERISTICS

**Note:** The graphs provided following this note are a statistical summary based on a limited number of samples and are provided for informational purposes only. The performance characteristics listed herein are not tested or guaranteed. In some graphs, the data presented may be outside the specified operating range (e.g., outside specified power supply range) and therefore outside the warranted range.

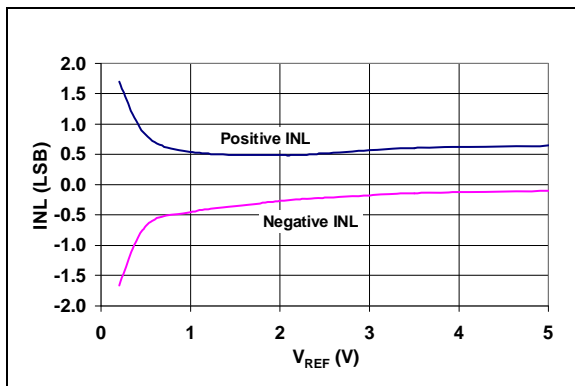
**Note:** Unless otherwise indicated,  $V_{DD} = V_{REF} = 5V$ ,  $V_{SS} = 0V$ ,  $f_{SAMPLE} = 100$  ksp/s,  $f_{CLK} = 16 * f_{SAMPLE}$ ,  $T_A = +25^{\circ}C$ .



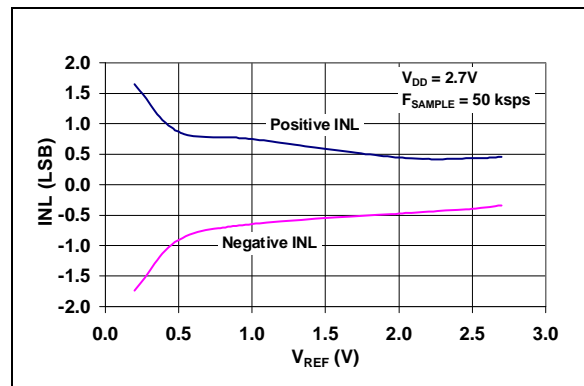
**FIGURE 2-1:** Integral Nonlinearity (INL) vs. Sample Rate.



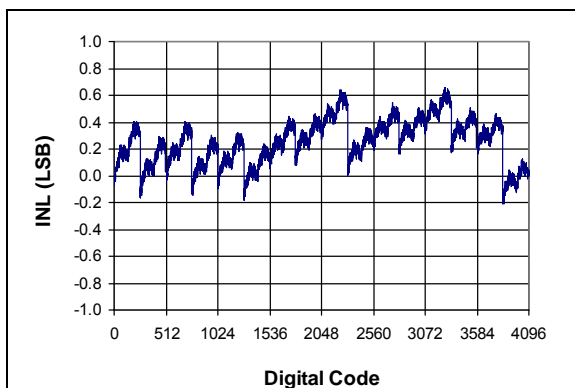
**FIGURE 2-4:** Integral Nonlinearity (INL) vs. Sample Rate ( $V_{DD} = 2.7V$ ).



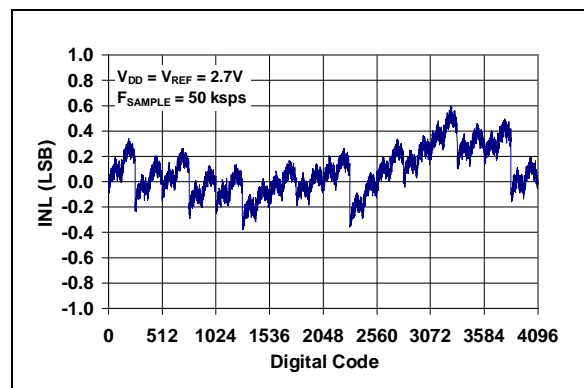
**FIGURE 2-2:** Integral Nonlinearity (INL) vs.  $V_{REF}$ .



**FIGURE 2-5:** Integral Nonlinearity (INL) vs.  $V_{REF}$  ( $V_{DD} = 2.7V$ ).



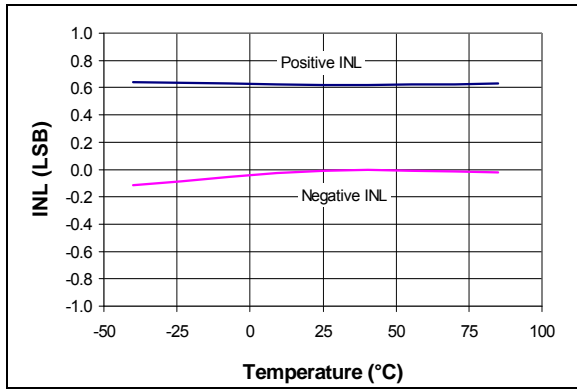
**FIGURE 2-3:** Integral Nonlinearity (INL) vs. Code (Representative Part).



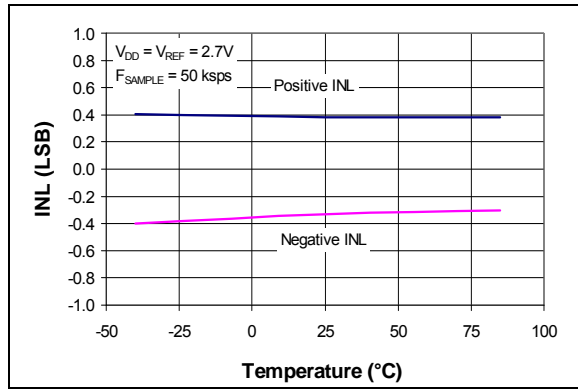
**FIGURE 2-6:** Integral Nonlinearity (INL) vs. Code (Representative Part,  $V_{DD} = 2.7V$ ).

# MCP3201

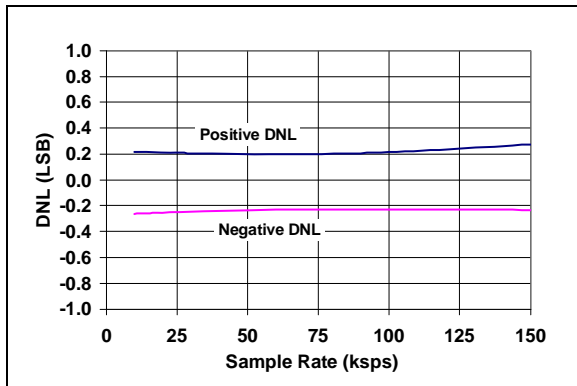
**Note:** Unless otherwise indicated,  $V_{DD} = V_{REF} = 5V$ ,  $V_{SS} = 0V$ ,  $f_{SAMPLE} = 100$  ksp/s,  $f_{CLK} = 16 \cdot f_{SAMPLE}$ ,  $T_A = +25^\circ C$ .



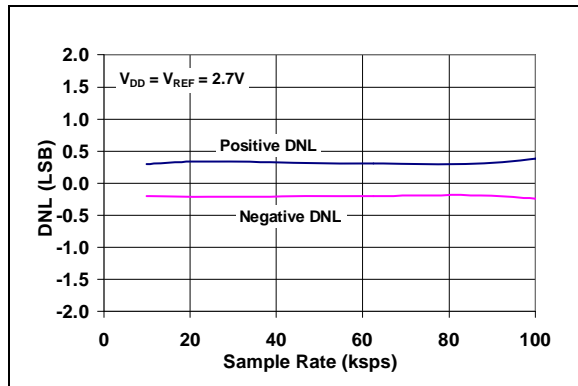
**FIGURE 2-7:** Integral Nonlinearity (INL) vs. Temperature.



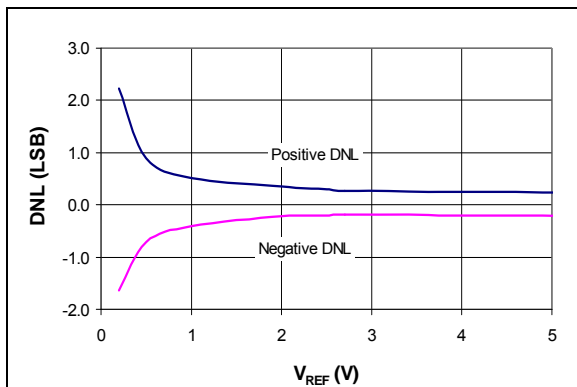
**FIGURE 2-10:** Integral Nonlinearity (INL) vs. Temperature ( $V_{DD} = 2.7V$ ).



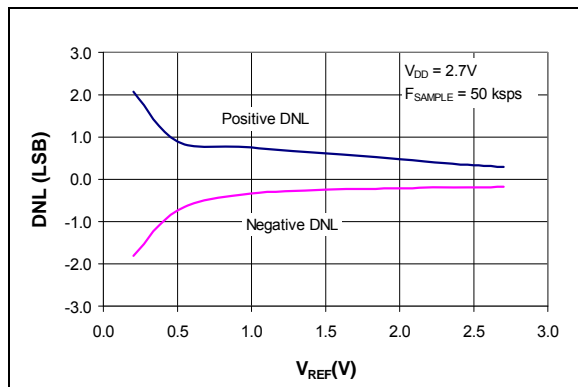
**FIGURE 2-8:** Differential Nonlinearity (DNL) vs. Sample Rate.



**FIGURE 2-11:** Differential Nonlinearity (DNL) vs. Sample Rate ( $V_{DD} = 2.7V$ ).

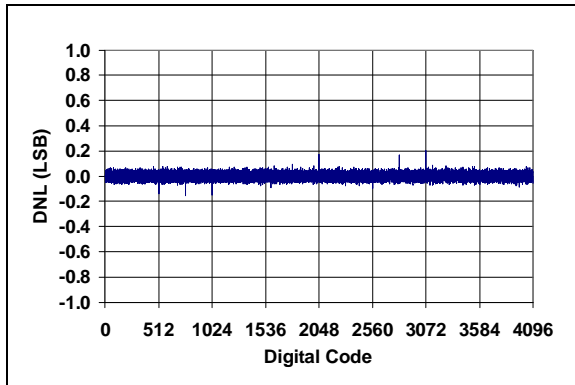


**FIGURE 2-9:** Differential Nonlinearity (DNL) vs.  $V_{REF}$

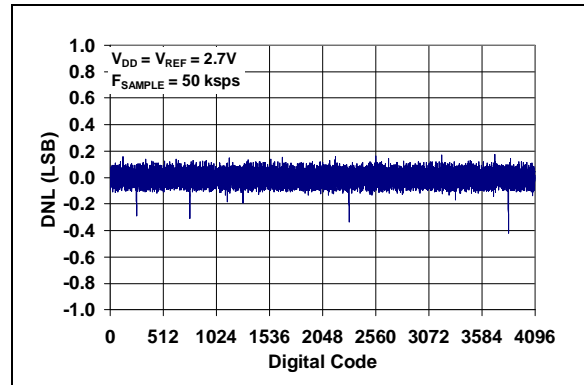


**FIGURE 2-12:** Differential Nonlinearity (DNL) vs.  $V_{REF}$  ( $V_{DD} = 2.7V$ ).

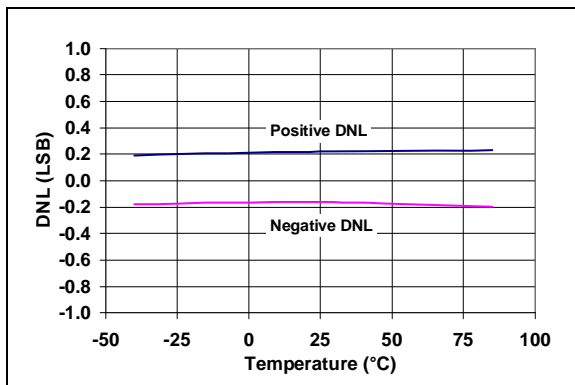
**Note:** Unless otherwise indicated,  $V_{DD} = V_{REF} = 5V$ ,  $V_{SS} = 0V$ ,  $f_{SAMPLE} = 100$  ksp/s,  $f_{CLK} = 16 \cdot f_{SAMPLE}$ ,  $T_A = +25^\circ C$ .



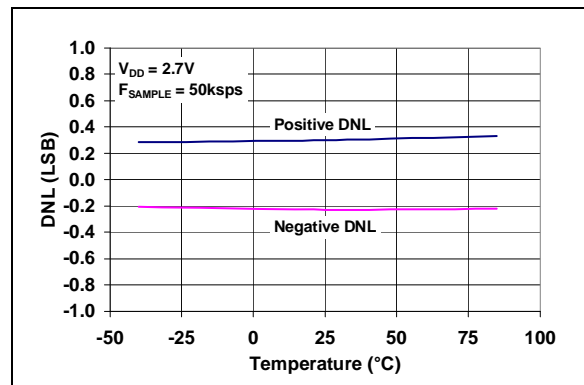
**FIGURE 2-13:** Differential Nonlinearity (DNL) vs. Code (Representative Part).



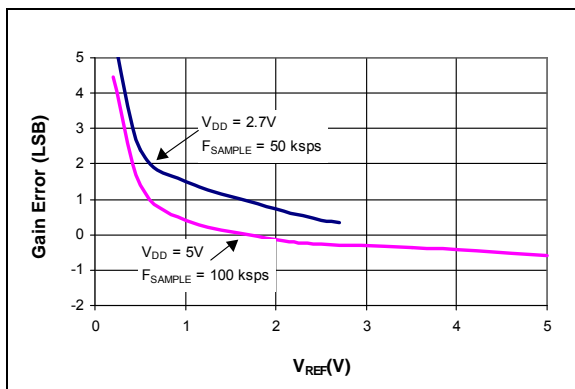
**FIGURE 2-16:** Differential Nonlinearity (DNL) vs. Code (Representative Part,  $V_{DD} = 2.7V$ ).



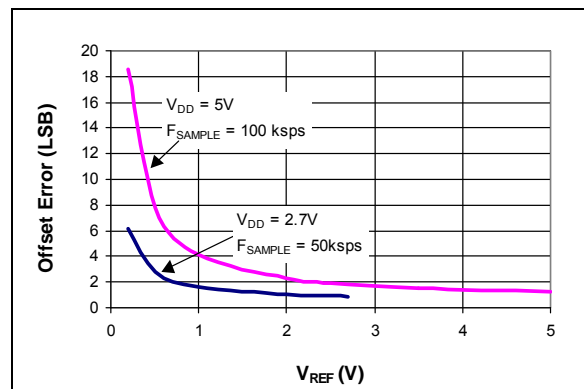
**FIGURE 2-14:** Differential Nonlinearity (DNL) vs. Temperature.



**FIGURE 2-17:** Differential Nonlinearity (DNL) vs. Temperature ( $V_{DD} = 2.7V$ ).



**FIGURE 2-15:** Gain Error vs.  $V_{REF}$



**FIGURE 2-18:** Offset Error vs.  $V_{REF}$

# MCP3201

Note: Unless otherwise indicated,  $V_{DD} = V_{REF} = 5V$ ,  $V_{SS} = 0V$ ,  $f_{SAMPLE} = 100$  kps,  $f_{CLK} = 16 \cdot f_{SAMPLE}$ ,  $T_A = +25^\circ C$ .

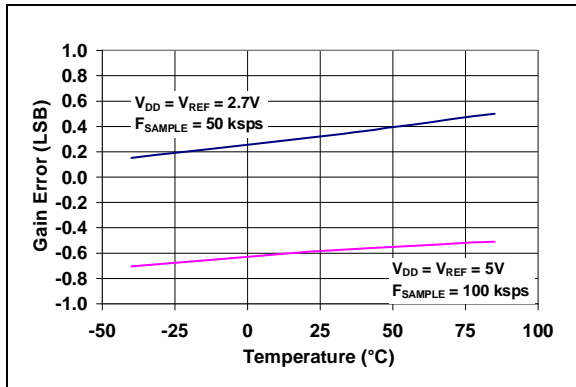


FIGURE 2-19: Gain Error vs. Temperature.

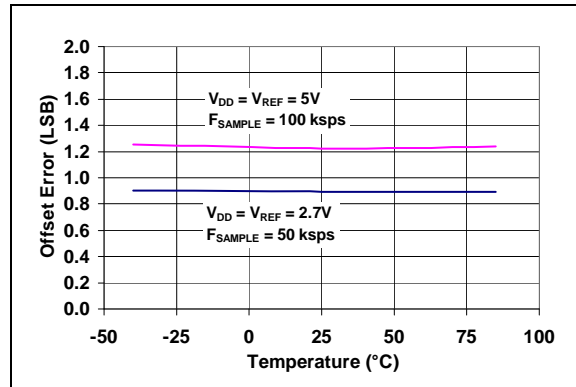


FIGURE 2-22: Offset Error vs. Temperature.

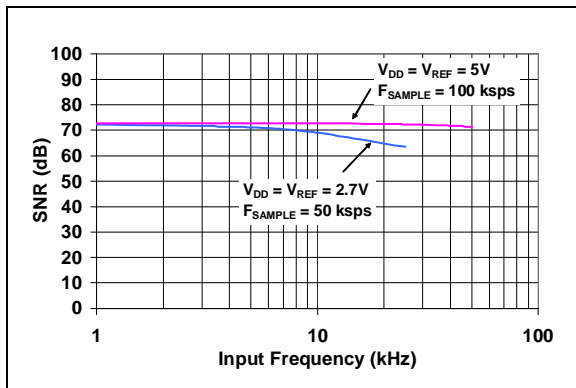


FIGURE 2-20: Signal-to-Noise Ratio (SNR) vs. Input Frequency.

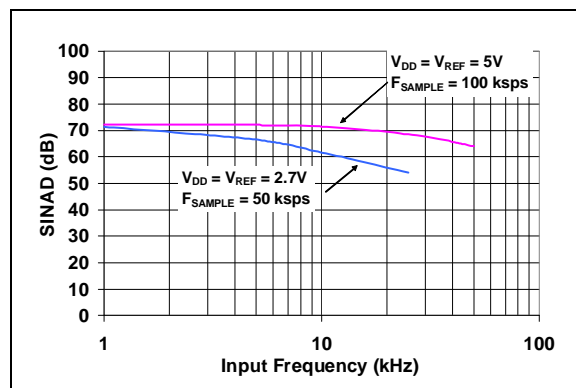


FIGURE 2-23: Signal-to-Noise and Distortion (SINAD) vs. Input Frequency.

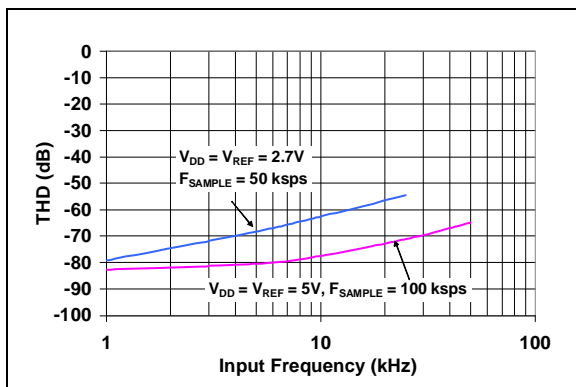


FIGURE 2-21: Total Harmonic Distortion (THD) vs. Input Frequency.

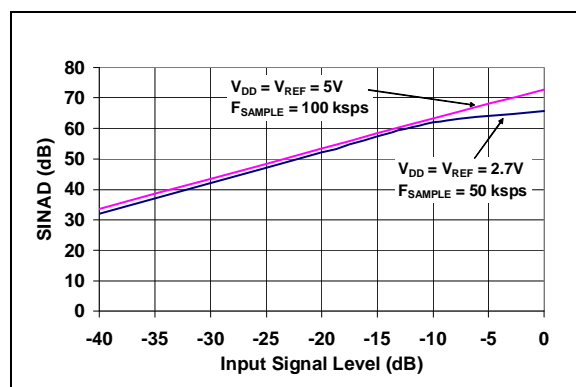
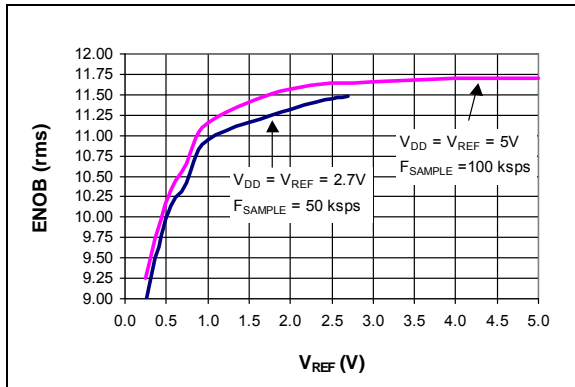
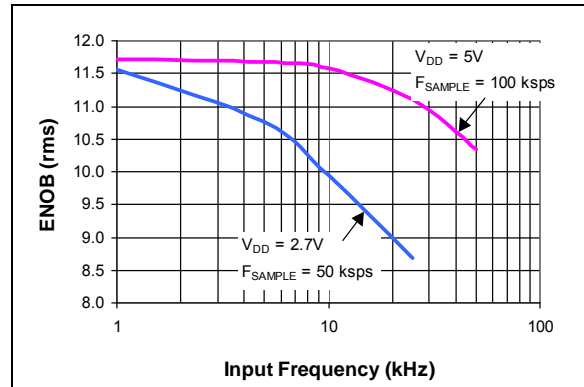


FIGURE 2-24: Signal-to-Noise and Distortion (SINAD) vs. Input Signal Level.

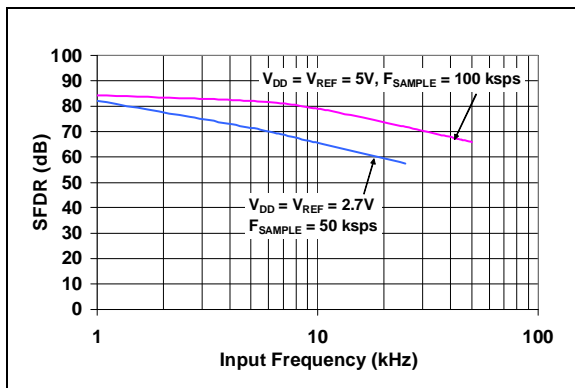
**Note:** Unless otherwise indicated,  $V_{DD} = V_{REF} = 5V$ ,  $V_{SS} = 0V$ ,  $f_{SAMPLE} = 100$  ksp/s,  $f_{CLK} = 16 \cdot f_{SAMPLE}$ ,  $T_A = +25^\circ C$ .



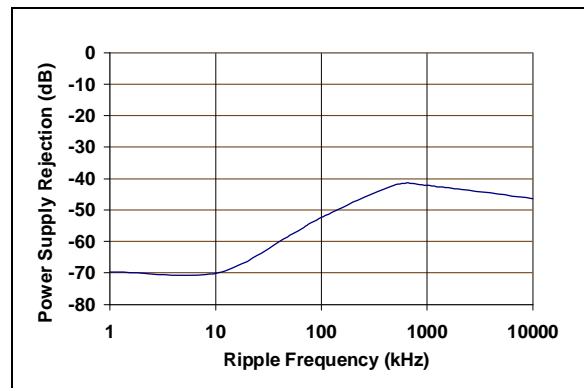
**FIGURE 2-25:** Effective Number of Bits (ENOB) vs.  $V_{REF}$



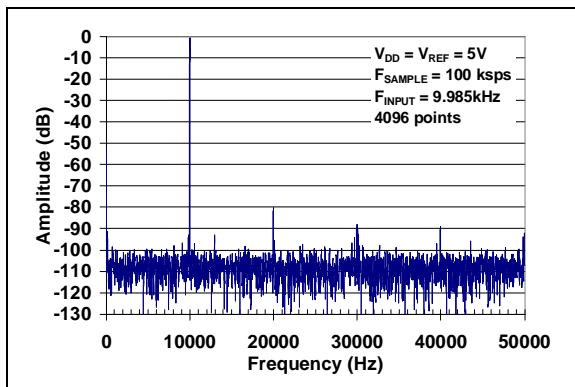
**FIGURE 2-28:** Effective Number of Bits (ENOB) vs. Input Frequency.



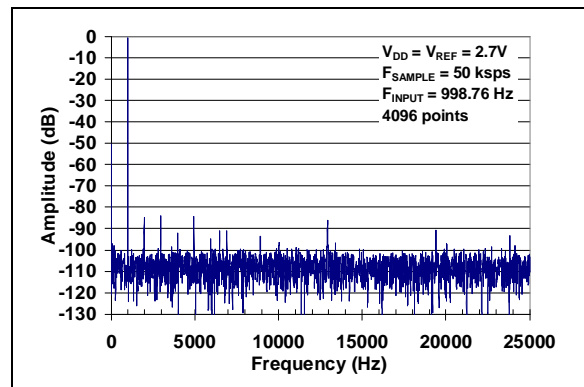
**FIGURE 2-26:** Spurious Free Dynamic Range (SFDR) vs. Input Frequency.



**FIGURE 2-29:** Power Supply Rejection (PSR) vs. Ripple Frequency.



**FIGURE 2-27:** Frequency Spectrum of 10 kHz input (Representative Part).



**FIGURE 2-30:** Frequency Spectrum of 1 kHz input (Representative Part,  $V_{DD} = 2.7V$ ).

# MCP3201

Note: Unless otherwise indicated,  $V_{DD} = V_{REF} = 5V$ ,  $V_{SS} = 0V$ ,  $f_{SAMPLE} = 100$  ksp/s,  $f_{CLK} = 16 \cdot f_{SAMPLE}$ ,  $T_A = +25^\circ C$ .

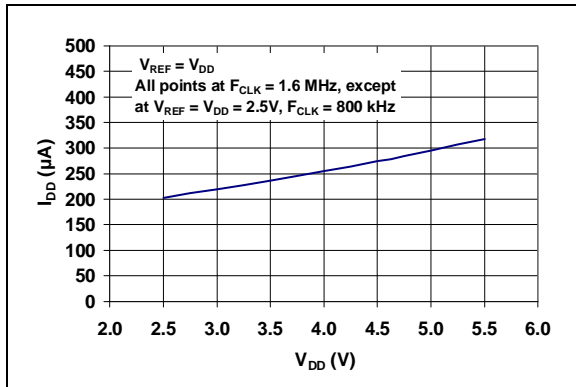


FIGURE 2-31:  $I_{DD}$  vs.  $V_{DD}$ .

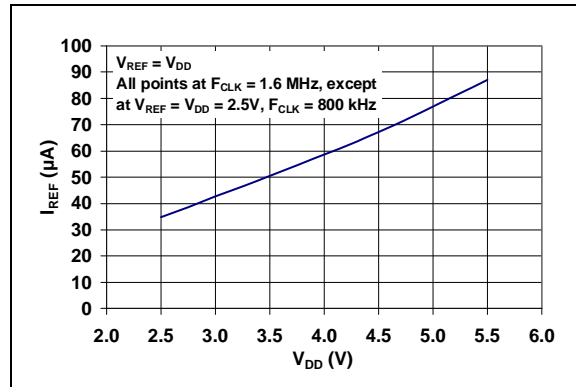


FIGURE 2-34:  $I_{REF}$  vs.  $V_{DD}$ .

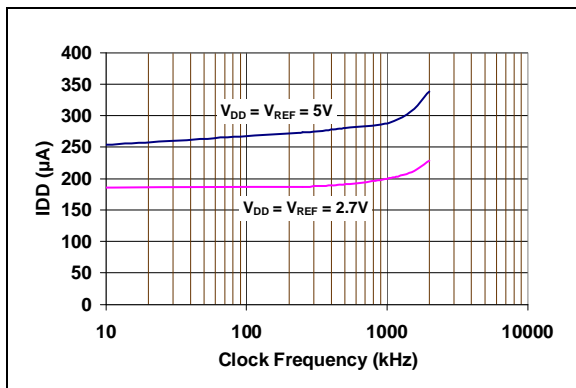


FIGURE 2-32:  $I_{DD}$  vs. Clock Frequency.

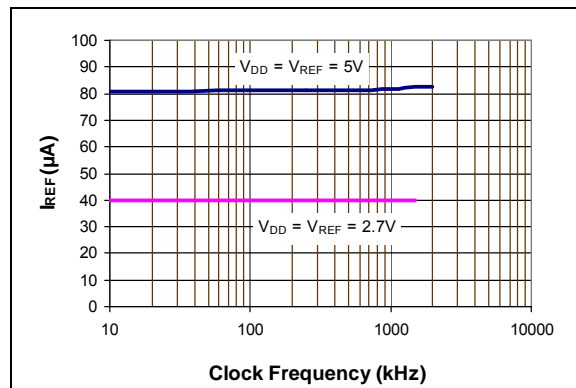


FIGURE 2-35:  $I_{REF}$  vs. Clock Frequency.

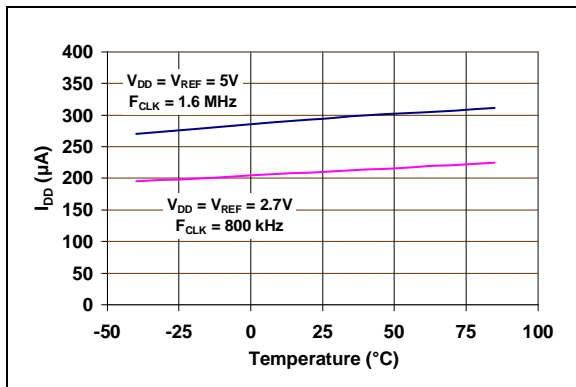


FIGURE 2-33:  $I_{DD}$  vs. Temperature.

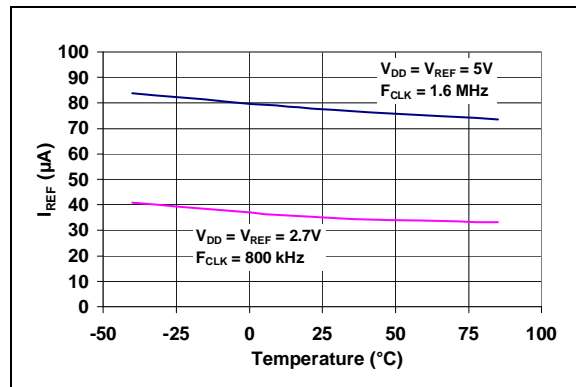
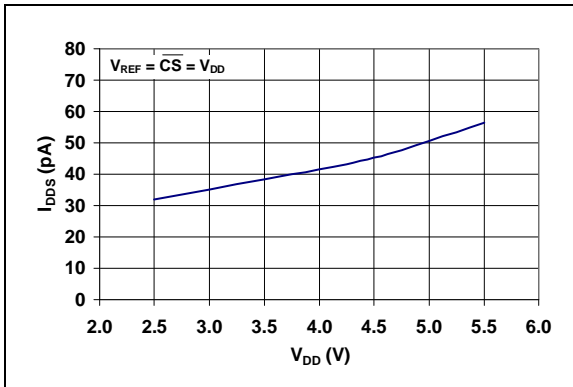
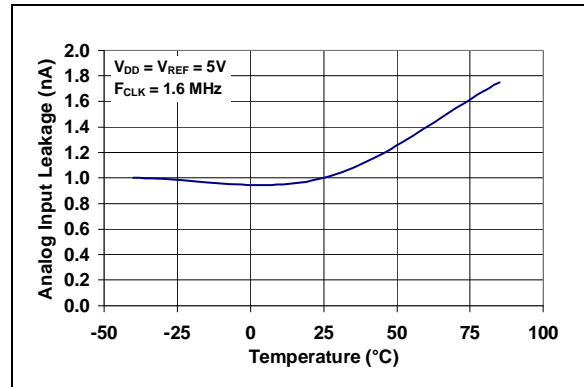


FIGURE 2-36:  $I_{REF}$  vs. Temperature.

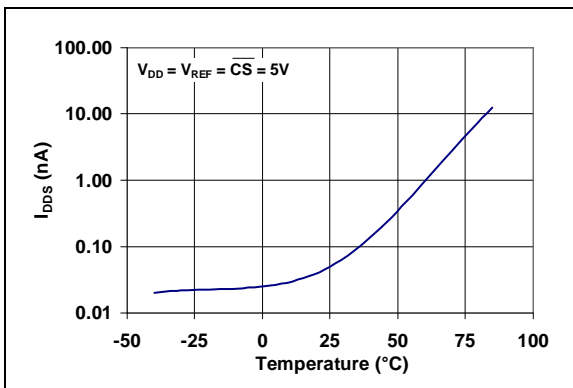
**Note:** Unless otherwise indicated,  $V_{DD} = V_{REF} = 5V$ ,  $V_{SS} = 0V$ ,  $f_{SAMPLE} = 100$  ksp/s,  $f_{CLK} = 16 \cdot f_{SAMPLE}$ ,  $T_A = +25^\circ C$ .



**FIGURE 2-37:**  $I_{DDS}$  vs.  $V_{DD}$ .



**FIGURE 2-39:** Analog Input Leakage Current vs. Temperature.



**FIGURE 2-38:**  $I_{DDS}$  vs. Temperature.

# MCP3201

---

NOTES:

### 3.0 PIN DESCRIPTIONS

The descriptions of the pins are listed in [Table 3-1](#).

Additional descriptions of the device pins follows.

**TABLE 3-1: PIN FUNCTION TABLE**

MCP3201	Symbol	Description
MSOP, PDIP, SOIC, TSSOP		
1	$V_{REF}$	Reference Voltage Input
2	IN+	Positive Analog Input
3	IN-	Negative Analog Input
4	$V_{SS}$	Ground
5	$\overline{CS}/SHDN$	Chip Select/Shutdown Input
6	$D_{OUT}$	Serial Data Out
7	CLK	Serial Clock
8	$V_{DD}$	+2.7V to 5.5V Power Supply

#### 3.1 Positive Analog Input (IN+)

Positive analog input. This input can vary from IN- to  $V_{REF} + IN-$ .

#### 3.2 Negative Analog Input (IN-)

Negative analog input. This input can vary  $\pm 100$  mV from  $V_{SS}$ .

#### 3.3 Chip Select/Shutdown ( $\overline{CS}/SHDN$ )

The  $\overline{CS}/SHDN$  pin is used to initiate communication with the device when pulled low and will end a conversion and put the device in low power standby when pulled high. The  $\overline{CS}/SHDN$  pin must be pulled high between conversions.

#### 3.4 Serial Clock (CLK)

The SPI clock pin is used to initiate a conversion and to clock out each bit of the conversion as it takes place. See [Section 6.2 “Maintaining Minimum Clock Speed”](#) for constraints on clock speed.

#### 3.5 Serial Data Output ( $D_{OUT}$ )

The SPI serial data output pin is used to shift out the results of the A/D conversion. Data will always change on the falling edge of each clock as the conversion takes place.

# MCP3201

---

NOTES:

## 4.0 DEVICE OPERATION

The MCP3201 A/D Converter employs a conventional SAR architecture. With this architecture, a sample is acquired on an internal sample/hold capacitor for 1.5 clock cycles starting on the first rising edge of the serial clock after  $\overline{CS}$  has been pulled low. Following this sample time, the input switch of the converter opens and the device uses the collected charge on the internal sample and hold capacitor to produce a serial 12-bit digital output code. Conversion rates of 100 ksp/s are possible on the MCP3201 device. See [Section 6.2 “Maintaining Minimum Clock Speed”](#) for information on minimum clock rates. Communication with the device is done using a 3-wire SPI-compatible interface.

### 4.1 Analog Inputs

The MCP3201 device provides a single pseudo-differential input. The IN+ input can range from IN- to  $V_{REF}$  ( $V_{REF} + IN-$ ). The IN- input is limited to  $\pm 100$  mV from the  $V_{SS}$  rail. The IN- input can be used to cancel small signal common-mode noise which is present on both the IN+ and IN- inputs.

For the A/D Converter to meet specification, the charge holding capacitor ( $C_{SAMPLE}$ ) must be given enough time to acquire a 12-bit accurate voltage level during the 1.5 clock cycle sampling period. The analog input model is shown in [Figure 4-1](#).

In this diagram, it is shown that the source impedance ( $R_S$ ) adds to the internal sampling switch ( $R_{SS}$ ) impedance, directly affecting the time that is required to charge the capacitor ( $C_{SAMPLE}$ ). Consequently, a larger source impedance increases the offset, gain, and integral linearity errors of the conversion.

Ideally, the impedance of the signal source should be near zero. This is achievable with an operational amplifier such as the MCP601, which has a closed loop output impedance of tens of ohms. The adverse affects of higher source impedances are shown in [Figure 4-2](#).

If the voltage level of IN+ is equal to or less than IN-, the resultant code will be 000h. If the voltage at IN+ is equal to or greater than  $\{[V_{REF} + (IN-)] - 1 \text{ LSB}\}$ , then the output code will be FFFh. If the voltage level at IN- is more than 1 LSB below  $V_{SS}$ , then the voltage level at the IN+ input will have to go below  $V_{SS}$  to see the 000h output code. Conversely, if IN- is more than 1 LSB above  $V_{SS}$ , then the FFFh code will not be seen unless the IN+ input level goes above  $V_{REF}$  level.

### 4.2 Reference Input

The reference input ( $V_{REF}$ ) determines the analog input voltage range and the LSB size, as shown below.

#### EQUATION 4-1:

$$LSB \text{ Size} = \frac{V_{REF}}{4096}$$

As the reference input is reduced, the LSB size is reduced accordingly. The theoretical digital output code produced by the A/D Converter is a function of the analog input signal and the reference input as shown below.

#### EQUATION 4-2:

$$Digital \text{ Output Code} = \frac{4096 * V_{IN}}{V_{REF}}$$

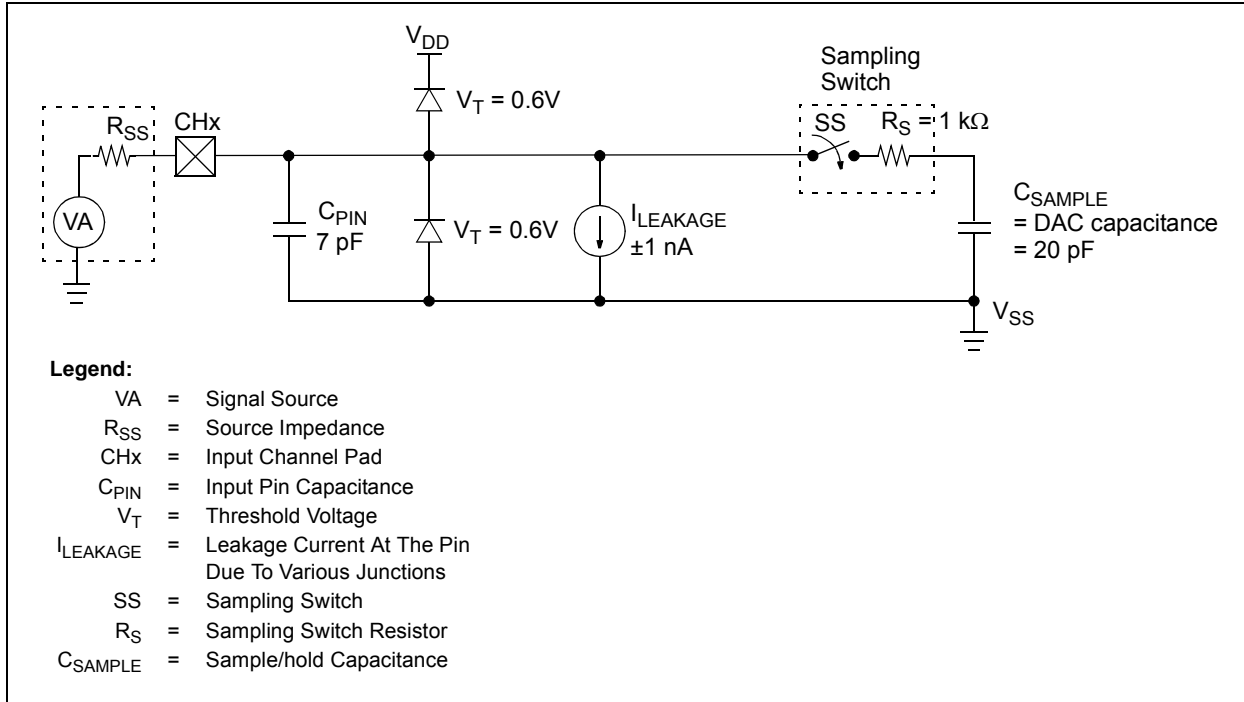
Where:

$$V_{IN} = \text{Analog Input Voltage} = V_{(IN+)} - V_{(IN-)}$$

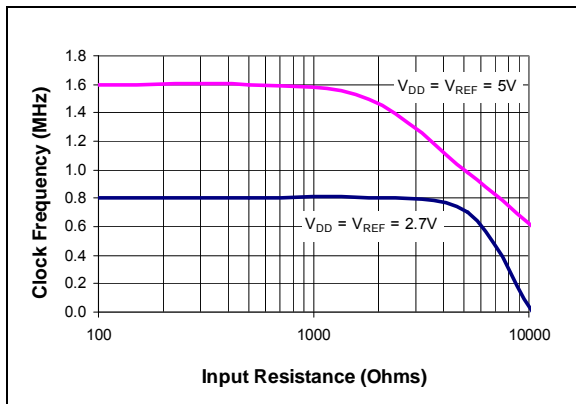
$$V_{REF} = \text{Reference Voltage}$$

When using an external voltage reference device, the system designer should always refer to the manufacturer's recommendations for circuit layout. Any instability in the operation of the reference device will have a direct effect on the operation of the A/D Converter.

# MCP3201



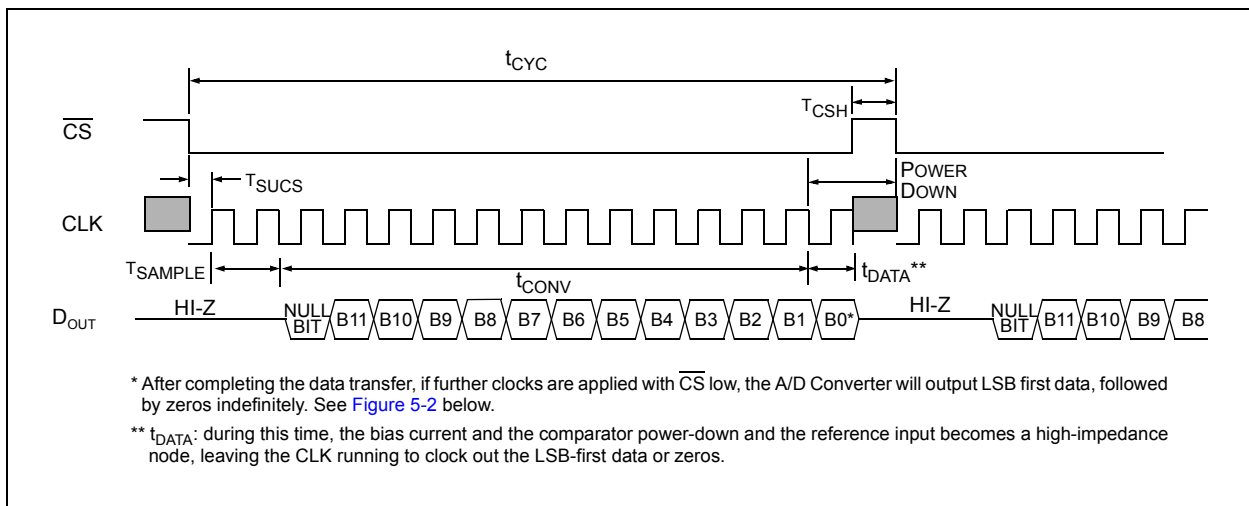
**FIGURE 4-1:** Analog Input Model.



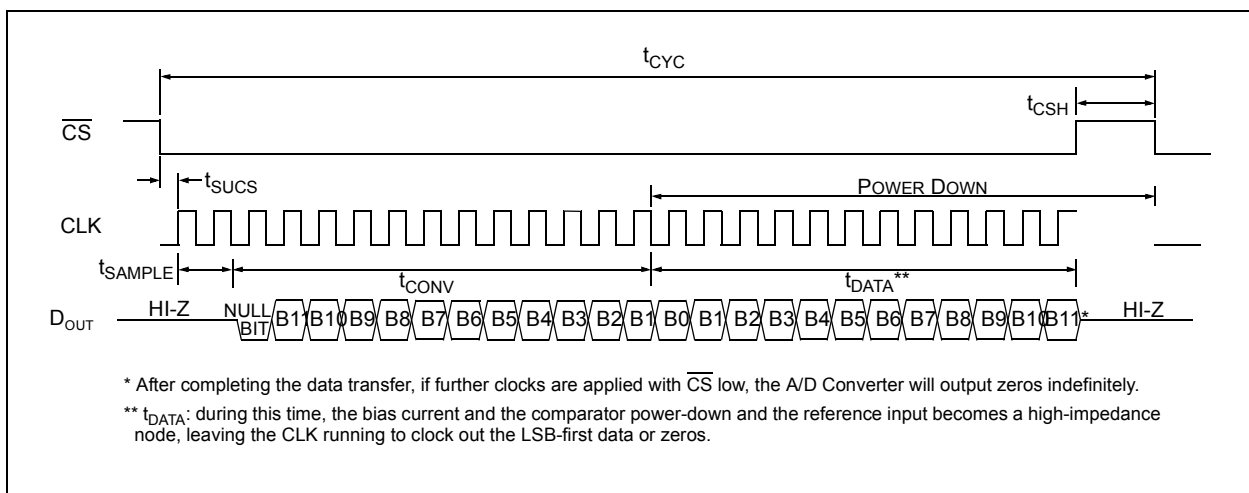
**FIGURE 4-2:** Maximum Clock Frequency vs. Input Resistance ( $R_S$ ) to maintain less than a 0.1 LSB deviation in INL from nominal conditions.

## 5.0 SERIAL COMMUNICATIONS

Communication with the device is done using a standard SPI-compatible serial interface. Initiating communication with the MCP3201 device begins with the  $\overline{CS}$  going low. If the device was powered up with the  $\overline{CS}$  pin low, it must be brought high and back low to initiate communication. The device will begin to sample the analog input on the first rising edge after  $\overline{CS}$  goes low. The sample period will end in the falling edge of the second clock, at which time the device will output a low null bit. The next 12 clocks will output the result of the conversion with MSB first, as shown in Figure 5-1. Data is always output from the device on the falling edge of the clock. If all 12 data bits have been transmitted and the device continues to receive clocks while the  $\overline{CS}$  is held low, the device will output the conversion result LSB first, as shown in Figure 5-2. If more clocks are provided to the device while  $\overline{CS}$  is still low (after the LSB first data has been transmitted), the device will clock out zeros indefinitely.



**FIGURE 5-1:** Communication with MCP3201 device using MSB first Format.



**FIGURE 5-2:** Communication with MCP3201 device using LSB first Format.

# MCP3201

---

NOTES:

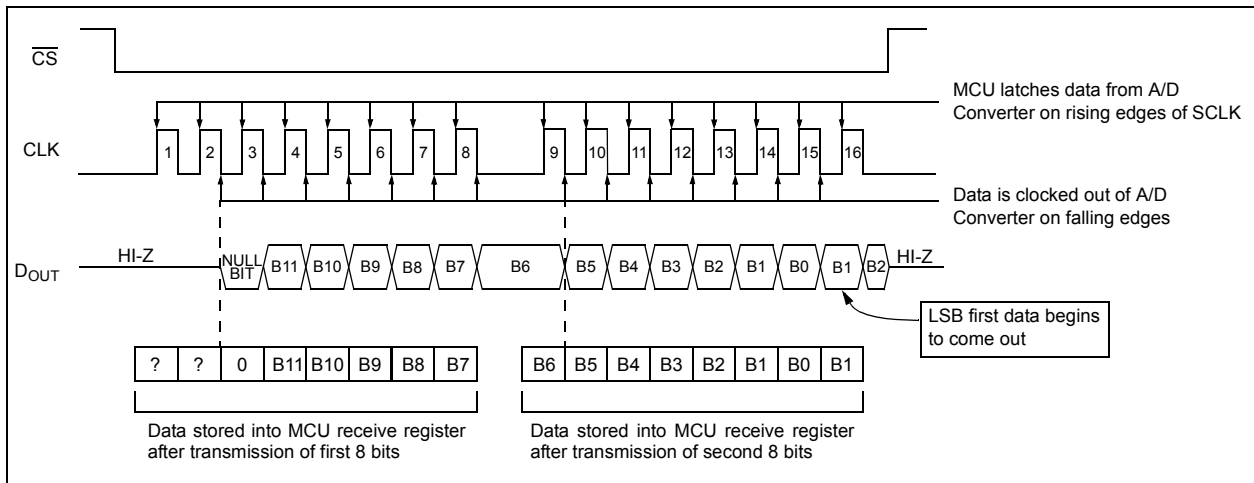
## 6.0 APPLICATIONS INFORMATION

### 6.1 Using the MCP3201 Device with Microcontroller SPI Ports

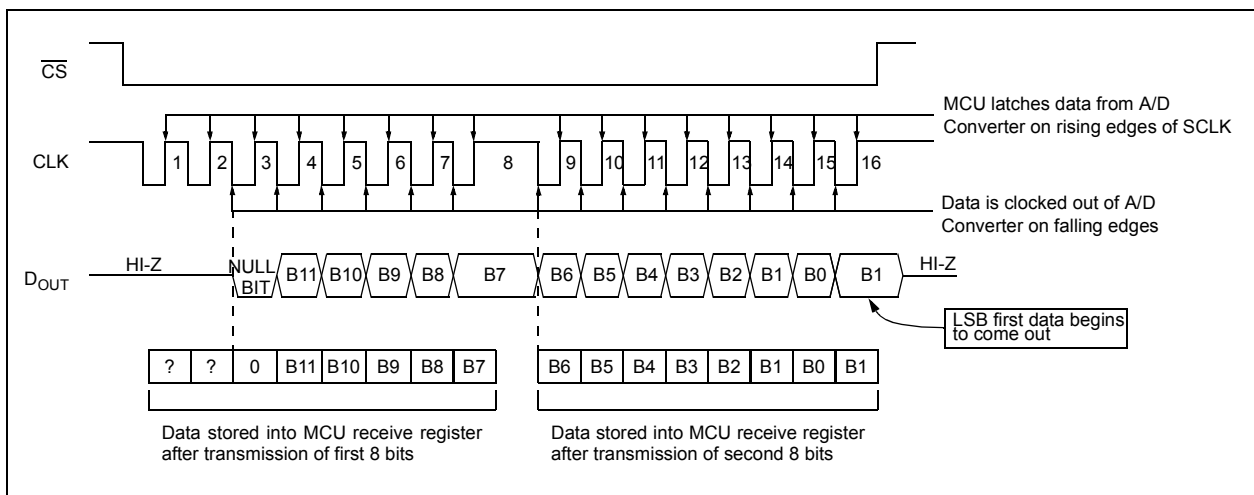
With most microcontroller SPI ports, it is required to clock out eight bits at a time. If this is the case, it will be necessary to provide more clocks than are required for the MCP3201. As an example, [Figure 6-1](#) and [Figure 6-2](#) show how the MCP3201 device can be interfaced to a microcontroller with a standard SPI port. Since the MCP3201 always clocks data out on the falling edge of clock, the MCU SPI port must be configured to match this operation. SPI Mode 0,0 (clock idles low) and SPI Mode 1,1 (clock idles high) are both compatible with the MCP3201. [Figure 6-1](#) depicts the operation shown in SPI Mode 0,0, which requires that the CLK from the microcontroller idles in the 'low' state. As shown in the diagram, the MSB is clocked out of the A/D Converter on the falling edge of the third clock pulse. After the first eight clocks have been sent to the

device, the microcontroller's receive buffer will contain two unknown bits (the output is at high-impedance for the first two clocks), the null bit and the highest order five bits of the conversion. After the second eight clocks have been sent to the device, the MCU receive register will contain the lowest-order seven bits and the B1 bit repeated as the A/D Converter has begun to shift out LSB first data with the extra clock. Typical procedure would then call for the lower-order byte of data to be shifted right by one bit to remove the extra B1 bit. The B7 bit is then transferred from the high-order byte to the lower-order byte, and then the higher-order byte is shifted one bit to the right as well. Easier manipulation of the converted data can be obtained by using this method.

[Figure 6-2](#) shows the same thing in SPI Mode 1,1 which requires that the clock idles in the high state. As with mode 0,0, the A/D Converter outputs data on the falling edge of the clock and the MCU latches data from the A/D Converter in on the rising edge of the clock.



**FIGURE 6-1:** SPI Communication using 8-bit segments (Mode 0,0: SCLK idles low).



**FIGURE 6-2:** SPI Communication using 8-bit segments (Mode 1,1: SCLK idles high).

# MCP3201

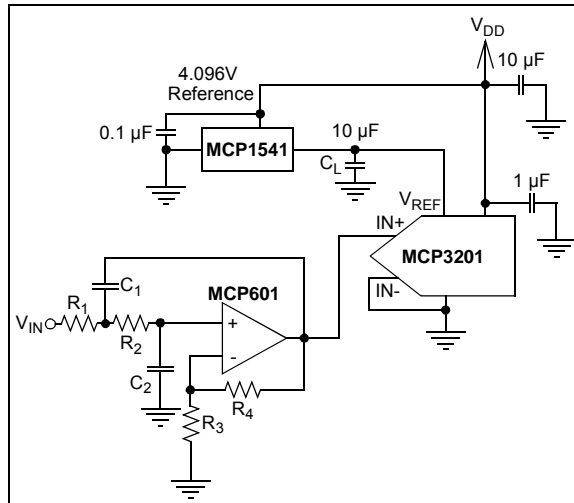
## 6.2 Maintaining Minimum Clock Speed

When the MCP3201 initiates the sample period, charge is stored on the sample capacitor. When the sample period is complete, the device converts one bit for each clock that is received. It is important for the user to note that a slow clock rate will allow charge to bleed off the sample cap while the conversion is taking place. At 85°C (worst-case condition), the part will maintain proper charge on the sample capacitor for at least 1.2 ms after the sample period has ended. This means that the time between the end of the sample period and the time that all 12 data bits have been clocked out must not exceed 1.2 ms (effective clock frequency of 10 kHz). Failure to meet this criteria may induce linearity errors into the conversion outside the rated specifications. It should be noted that during the entire conversion cycle, the A/D Converter does not require a constant clock speed or duty cycle, as long as all timing specifications are met.

## 6.3 Buffering/Filtering the Analog Inputs

If the signal source for the A/D Converter is not a low-impedance source, it will have to be buffered or inaccurate conversion results may occur. See [Figure 4-2](#). It is also recommended that a filter be used to eliminate any signals that may be aliased back into the conversion results. This is illustrated in [Figure 6-3](#) where an op amp is used to drive the analog input of the MCP3201 device. This amplifier provides a low-impedance source for the converter input and a low-pass filter, which eliminates unwanted high-frequency noise.

Low-pass (anti-aliasing) filters can be designed using Microchip's interactive FilterLab<sup>®</sup> software. FilterLab will calculate capacitor and resistor values, as well as determine the number of poles that are required for the application. For more information on filtering signals, see application note AN699 "Anti-Aliasing Analog Filters for Data Acquisition Systems."



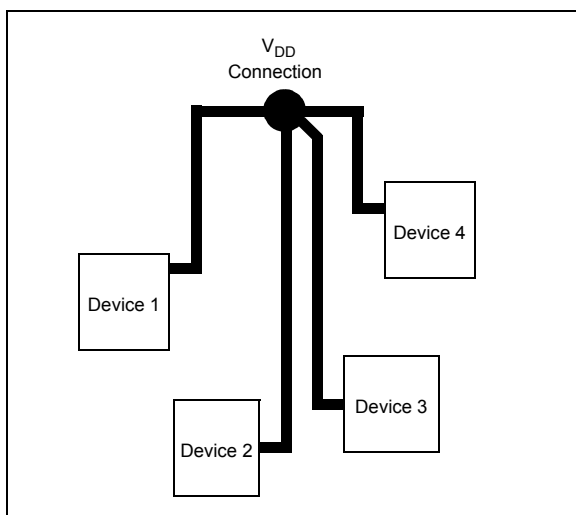
**FIGURE 6-3:** The MCP601 Operational Amplifier is used to implement a 2nd order anti-aliasing filter for the signal being converted by the MCP3201 device.

## 6.4 Layout Considerations

When laying out a printed circuit board for use with analog components, care should be taken to reduce noise wherever possible. A bypass capacitor should always be used with this device and should be placed as close as possible to the device pin. A bypass capacitor value of 1  $\mu\text{F}$  is recommended.

Digital and analog traces should be separated as much as possible on the board and no traces should run underneath the device or the bypass capacitor. Extra precautions should be taken to keep traces with high-frequency signals (such as clock lines) as far as possible from analog traces.

Use of an analog ground plane is recommended in order to keep the ground potential the same for all devices on the board. Providing  $V_{\text{DD}}$  connections to devices in a “star” configuration can also reduce noise by eliminating current return paths and associated errors. See Figure 6-4. For more information on layout tips when using A/D Converter, refer to AN688 “Layout Tips for 12-Bit A/D Converter Applications”.



**FIGURE 6-4:**  $V_{\text{DD}}$  traces arranged in a ‘Star’ configuration in order to reduce errors caused by current return paths.

# MCP3201

---

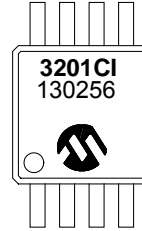
NOTES:

**7.0 PACKAGING INFORMATION****7.1 Package Marking Information**

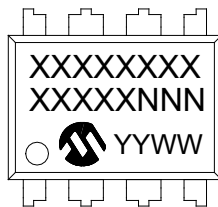
8-Lead MSOP (3x3 mm)



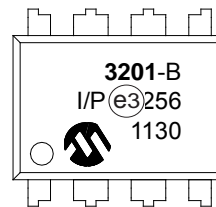
Example



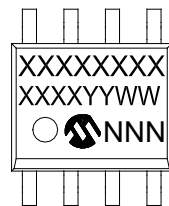
8-Lead PDIP (300 mil)



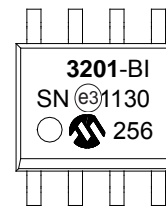
Example



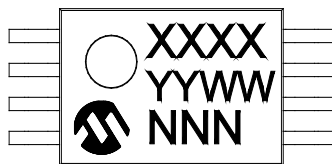
8-Lead SOIC (3.90 mm)



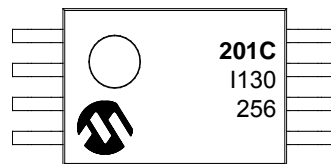
Example



8-Lead TSSOP (4.4 mm)



Example



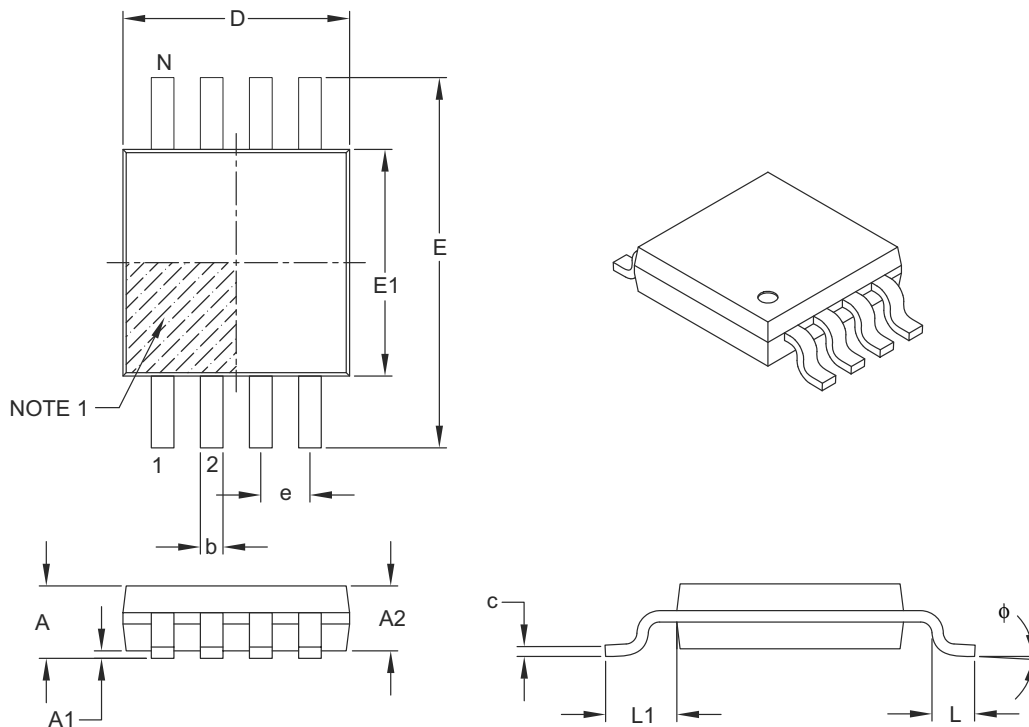
<b>Legend:</b>	XX...X	Customer-specific information
	Y	Year code (last digit of calendar year)
	YY	Year code (last 2 digits of calendar year)
	WW	Week code (week of January 1 is week '01')
	NNN	Alphanumeric traceability code
	(e3)	Pb-free JEDEC designator for Matte Tin (Sn)
	*	This package is Pb-free. The Pb-free JEDEC designator (e3) can be found on the outer packaging for this package.

**Note:** In the event the full Microchip part number cannot be marked on one line, it will be carried over to the next line, thus limiting the number of available characters for customer-specific information.

# MCP3201

## 8-Lead Plastic Micro Small Outline Package (MS) [MSOP]

**Note:** For the most current package drawings, please see the Microchip Packaging Specification located at <http://www.microchip.com/packaging>



Dimension Limits	Units	MILLIMETERS		
		MIN	NOM	MAX
Number of Pins	N	8		
Pitch	e	0.65 BSC		
Overall Height	A	–	–	1.10
Molded Package Thickness	A2	0.75	0.85	0.95
Standoff	A1	0.00	–	0.15
Overall Width	E	4.90 BSC		
Molded Package Width	E1	3.00 BSC		
Overall Length	D	3.00 BSC		
Foot Length	L	0.40	0.60	0.80
Footprint	L1	0.95 REF		
Foot Angle	$\phi$	0°	–	8°
Lead Thickness	c	0.08	–	0.23
Lead Width	b	0.22	–	0.40

### Notes:

- Pin 1 visual index feature may vary, but must be located within the hatched area.
- Dimensions D and E1 do not include mold flash or protrusions. Mold flash or protrusions shall not exceed 0.15 mm per side.
- Dimensioning and tolerancing per ASME Y14.5M.

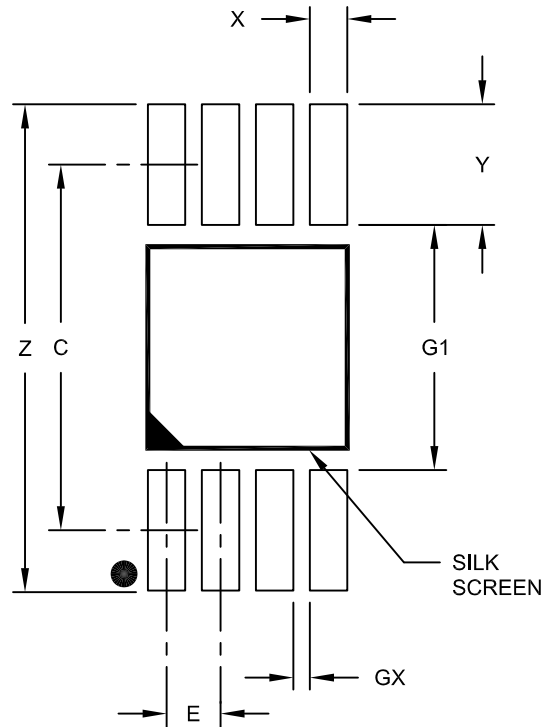
BSC: Basic Dimension. Theoretically exact value shown without tolerances.

REF: Reference Dimension, usually without tolerance, for information purposes only.

Microchip Technology Drawing C04-111B

## 8-Lead Plastic Micro Small Outline Package (MS) [MSOP]

**Note:** For the most current package drawings, please see the Microchip Packaging Specification located at <http://www.microchip.com/packaging>



RECOMMENDED LAND PATTERN

		MILLIMETERS		
Units		MIN	NOM	MAX
Dimension Limits				
Contact Pitch	E	0.65 BSC		
Contact Pad Spacing	C		4.40	
Overall Width	Z			5.85
Contact Pad Width (X8)	X1			0.45
Contact Pad Length (X8)	Y1			1.45
Distance Between Pads	G1	2.95		
Distance Between Pads	GX	0.20		

## Notes:

1. Dimensioning and tolerancing per ASME Y14.5M

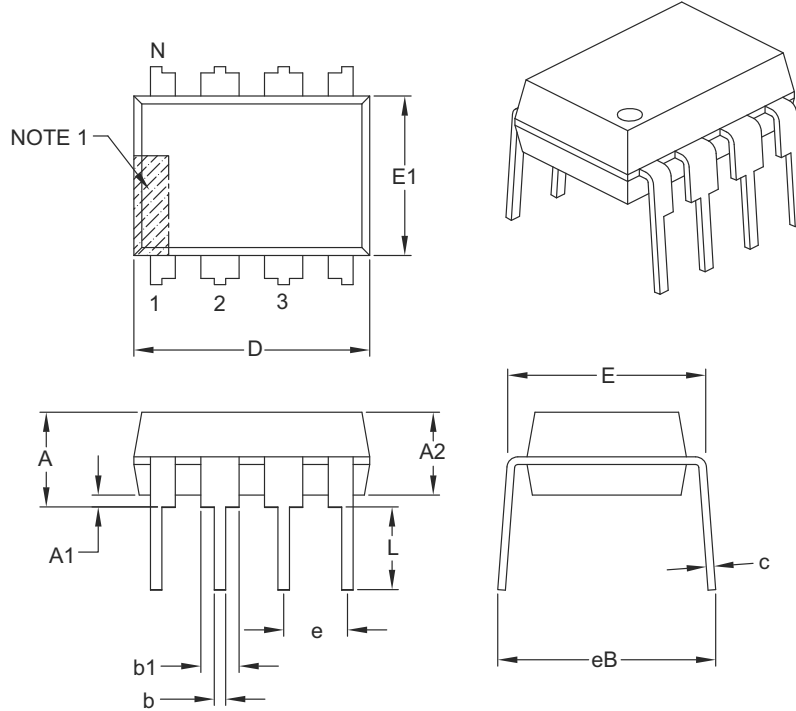
BSC: Basic Dimension. Theoretically exact value shown without tolerances.

Microchip Technology Drawing No. C04-2111A

# MCP3201

## 8-Lead Plastic Dual In-Line (P) – 300 mil Body [PDIP]

**Note:** For the most current package drawings, please see the Microchip Packaging Specification located at <http://www.microchip.com/packaging>



Dimension Limits	Units	INCHES		
		MIN	NOM	MAX
Number of Pins	N	8		
Pitch	e	.100 BSC		
Top to Seating Plane	A	–	–	.210
Molded Package Thickness	A2	.115	.130	.195
Base to Seating Plane	A1	.015	–	–
Shoulder to Shoulder Width	E	.290	.310	.325
Molded Package Width	E1	.240	.250	.280
Overall Length	D	.348	.365	.400
Tip to Seating Plane	L	.115	.130	.150
Lead Thickness	c	.008	.010	.015
Upper Lead Width	b1	.040	.060	.070
Lower Lead Width	b	.014	.018	.022
Overall Row Spacing §	eB	–	–	.430

### Notes:

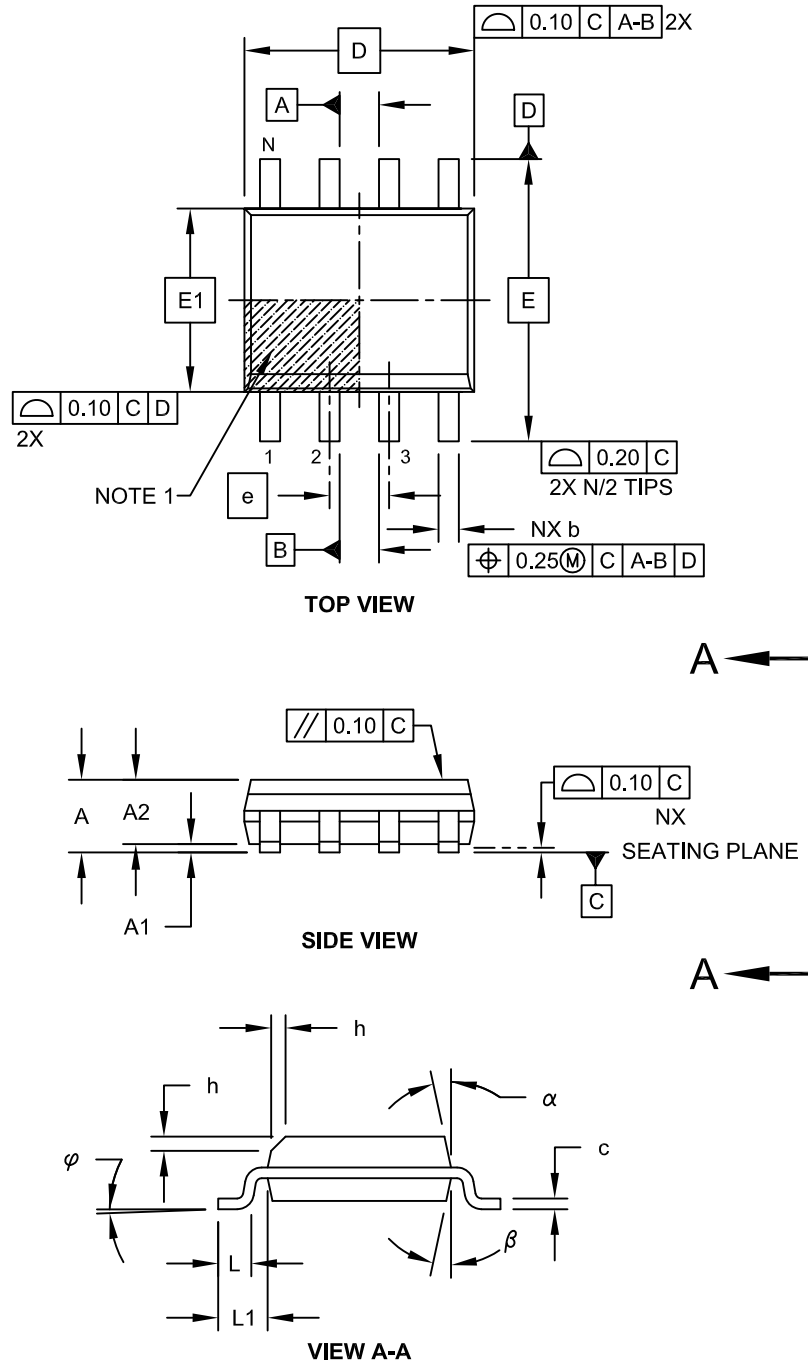
- Pin 1 visual index feature may vary, but must be located with the hatched area.
- § Significant Characteristic.
- Dimensions D and E1 do not include mold flash or protrusions. Mold flash or protrusions shall not exceed .010" per side.
- Dimensioning and tolerancing per ASME Y14.5M.

BSC: Basic Dimension. Theoretically exact value shown without tolerances.

Microchip Technology Drawing C04-018B

**8-Lead Plastic Small Outline (SN) - Narrow, 3.90 mm Body [SOIC]**

**Note:** For the most current package drawings, please see the Microchip Packaging Specification located at <http://www.microchip.com/packaging>

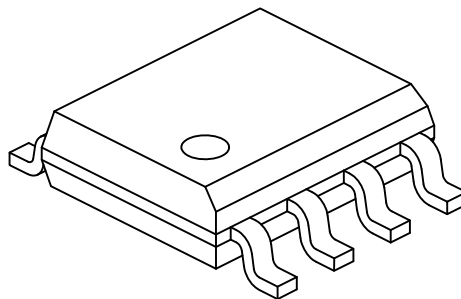


Microchip Technology Drawing No. C04-057C Sheet 1 of 2

# MCP3201

## 8-Lead Plastic Small Outline (SN) - Narrow, 3.90 mm Body [SOIC]

**Note:** For the most current package drawings, please see the Microchip Packaging Specification located at <http://www.microchip.com/packaging>



Dimension Limits	Units	MILLIMETERS		
		MIN	NOM	MAX
Number of Pins	N	8		
Pitch	e	1.27 BSC		
Overall Height	A	-	-	1.75
Molded Package Thickness	A2	1.25	-	-
Standoff §	A1	0.10	-	0.25
Overall Width	E	6.00 BSC		
Molded Package Width	E1	3.90 BSC		
Overall Length	D	4.90 BSC		
Chamfer (Optional)	h	0.25	-	0.50
Foot Length	L	0.40	-	1.27
Footprint	L1	1.04 REF		
Foot Angle	$\varphi$	0°	-	8°
Lead Thickness	c	0.17	-	0.25
Lead Width	b	0.31	-	0.51
Mold Draft Angle Top	$\alpha$	5°	-	15°
Mold Draft Angle Bottom	$\beta$	5°	-	15°

**Notes:**

- Pin 1 visual index feature may vary, but must be located within the hatched area.
- § Significant Characteristic
- Dimensions D and E1 do not include mold flash or protrusions. Mold flash or protrusions shall not exceed 0.15mm per side.
- Dimensioning and tolerancing per ASME Y14.5M

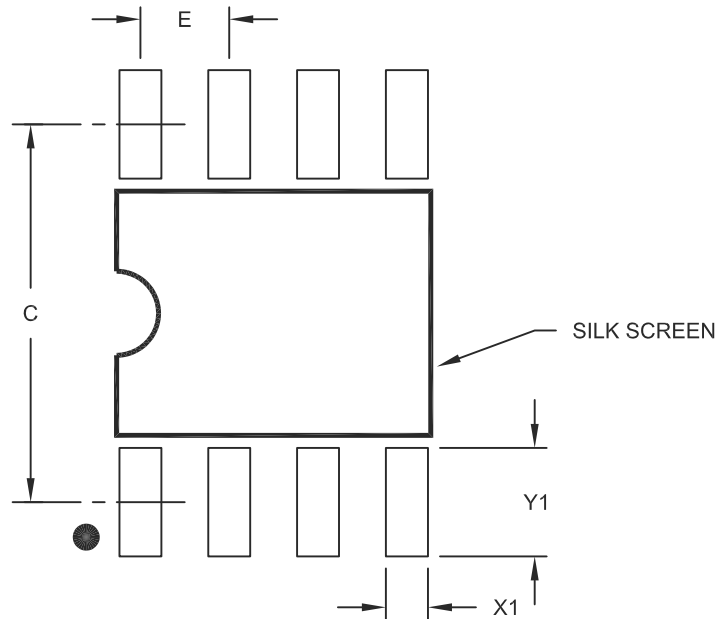
BSC: Basic Dimension. Theoretically exact value shown without tolerances.

REF: Reference Dimension, usually without tolerance, for information purposes only.

Microchip Technology Drawing No. C04-057C Sheet 2 of 2

**8-Lead Plastic Small Outline (SN) – Narrow, 3.90 mm Body [SOIC]**

**Note:** For the most current package drawings, please see the Microchip Packaging Specification located at <http://www.microchip.com/packaging>



RECOMMENDED LAND PATTERN

Dimension Limits	Units	MILLIMETERS		
		MIN	NOM	MAX
Contact Pitch	E	1.27 BSC		
Contact Pad Spacing	C		5.40	
Contact Pad Width (X8)	X1			0.60
Contact Pad Length (X8)	Y1			1.55

## Notes:

1. Dimensioning and tolerancing per ASME Y14.5M

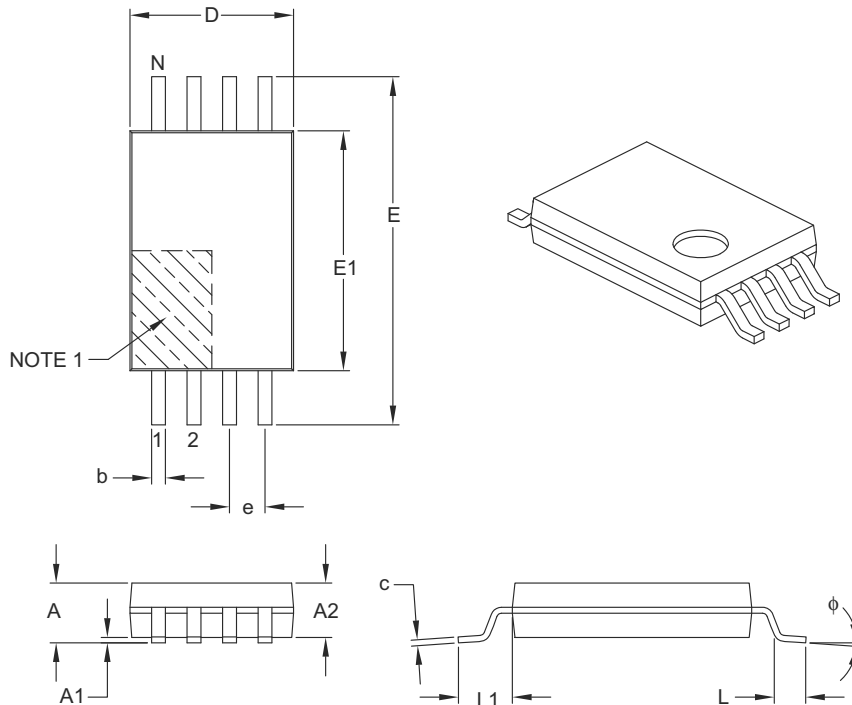
BSC: Basic Dimension. Theoretically exact value shown without tolerances.

Microchip Technology Drawing No. C04-2057A

# MCP3201

## 8-Lead Plastic Thin Shrink Small Outline (ST) – 4.4 mm Body [TSSOP]

**Note:** For the most current package drawings, please see the Microchip Packaging Specification located at <http://www.microchip.com/packaging>



Dimension Limits	Units	MILLIMETERS		
		MIN	NOM	MAX
Number of Pins	N	8		
Pitch	e	0.65 BSC		
Overall Height	A	–	–	1.20
Molded Package Thickness	A2	0.80	1.00	1.05
Standoff	A1	0.05	–	0.15
Overall Width	E	6.40 BSC		
Molded Package Width	E1	4.30	4.40	4.50
Molded Package Length	D	2.90	3.00	3.10
Foot Length	L	0.45	0.60	0.75
Footprint	L1	1.00 REF		
Foot Angle	$\phi$	0°	–	8°
Lead Thickness	c	0.09	–	0.20
Lead Width	b	0.19	–	0.30

### Notes:

- Pin 1 visual index feature may vary, but must be located within the hatched area.
- Dimensions D and E1 do not include mold flash or protrusions. Mold flash or protrusions shall not exceed 0.15 mm per side.
- Dimensioning and tolerancing per ASME Y14.5M.

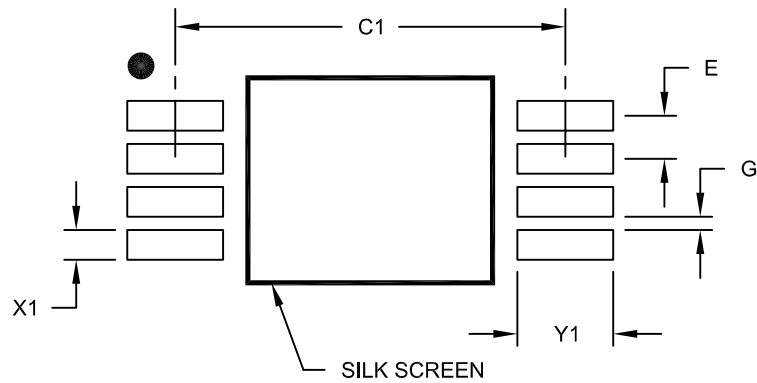
BSC: Basic Dimension. Theoretically exact value shown without tolerances.

REF: Reference Dimension, usually without tolerance, for information purposes only.

Microchip Technology Drawing C04-086B

**8-Lead Plastic Thin Shrink Small Outline (ST) - 4.4 mm Body [TSSOP]**

**Note:** For the most current package drawings, please see the Microchip Packaging Specification located at <http://www.microchip.com/packaging>

**RECOMMENDED LAND PATTERN**

Units		MILLIMETERS		
Dimension Limits		MIN	NOM	MAX
Contact Pitch	E	0.65 BSC		
Contact Pad Spacing	C1		5.90	
Contact Pad Width (X8)	X1			0.45
Contact Pad Length (X8)	Y1			1.45
Distance Between Pads	G	0.20		

**Notes:**

1. Dimensioning and tolerancing per ASME Y14.5M

BSC: Basic Dimension. Theoretically exact value shown without tolerances.

Microchip Technology Drawing No. C04-2086A

# MCP3201

---

NOTES:

**APPENDIX A: REVISION HISTORY****Revision F (August 2011)**

- Updated **Product Identification System** section.
  - Corrected marking drawings for MSOP packages.
  - Updated PDIP, SOIC, and TSSOP package specification drawings.

**Revision E (November 2008)**

The following is the list of modifications:

1. Updated **Section 7.0 “Packaging Information”**.
2. Updated **Product Identification System** section.

**Revision D (January 2007)**

The following is the list of modifications:

1. This revision includes updates to the packaging diagrams.

**Revision C (August 2001)**

The following is the list of modifications:

1. This revision includes undocumented changes.

**Revision B (August 1999)**

The following is the list of modifications:

1. This revision includes undocumented changes.

**Revision A (September 1998)**

- Original release of this document.

# MCP3201

---

NOTES:

**PRODUCT IDENTIFICATION SYSTEM**

To order or obtain information, e.g., on pricing or delivery, refer to the factory or the listed sales office.

<u>PART NO.</u>	<u>X</u>	<u>X</u>	<u>/XX</u>
Device	Grade	Temperature Range	Package
<b>Device:</b> MCP3201: 12-Bit A/D Converter w/SPI Interface MCP3201T: 12-Bit A/D Converter w/SPI Interface (Tape and Reel)	<b>Grade:</b> B: = $\pm$ LSB max INL (MSOP and TSSOP not available) C: = $\pm$ LSB max INL	<b>Temperature Range:</b> I = -40°C to +85°C (Industrial)	<b>Package:</b> MS = Plastic Micro Small Outline (MSOP), 8-lead P = Plastic DIP (300 mil Body), 8-lead SN = Plastic SOIC (150 mil Body), 8-lead ST = Plastic TSSOP (4.4 mm), 8-lead
<b>Examples:</b>			
a) MCP3201-BI/P:	B Grade,	Industrial Temperature,	8LD PDIP package.
b) MCP3201-BI/SN:	B Grade,	Industrial Temperature,	8LD SOIC package.
c) MCP3201-CI/P:	C Grade,	Industrial Temperature,	8LD PDIP package.
d) MCP3201-CI/MS:	C Grade,	Industrial Temperature,	8LD MSOP package.
e) MCP3201-CI/SN:	C Grade,	Industrial Temperature,	8LD SOIC package.
f) MCP3201-CI/ST:	C Grade,	Industrial Temperature,	8LD TSSOP package.
g) MCP3201T-BI/SN:	Tape and Reel, B Grade,	Industrial Temperature,	8LD SOIC package.
h) MCP3201T-CI/MS:	Tape and Reel, C Grade,	Industrial Temperature,	8LD MSOP package.
i) MCP3201T-CI/SN:	Tape and Reel, C Grade,	Industrial Temperature,	8LD SOIC package.
j) MCP3201T-CI/ST:	Tape and Reel, C Grade,	Industrial Temperature,	8LD TSSOP package.

# MCP3201

---

NOTES:

**Note the following details of the code protection feature on Microchip devices:**

- Microchip products meet the specification contained in their particular Microchip Data Sheet.
- Microchip believes that its family of products is one of the most secure families of its kind on the market today, when used in the intended manner and under normal conditions.
- There are dishonest and possibly illegal methods used to breach the code protection feature. All of these methods, to our knowledge, require using the Microchip products in a manner outside the operating specifications contained in Microchip's Data Sheets. Most likely, the person doing so is engaged in theft of intellectual property.
- Microchip is willing to work with the customer who is concerned about the integrity of their code.
- Neither Microchip nor any other semiconductor manufacturer can guarantee the security of their code. Code protection does not mean that we are guaranteeing the product as “unbreakable.”

Code protection is constantly evolving. We at Microchip are committed to continuously improving the code protection features of our products. Attempts to break Microchip's code protection feature may be a violation of the Digital Millennium Copyright Act. If such acts allow unauthorized access to your software or other copyrighted work, you may have a right to sue for relief under that Act.

Information contained in this publication regarding device applications and the like is provided only for your convenience and may be superseded by updates. It is your responsibility to ensure that your application meets with your specifications. MICROCHIP MAKES NO REPRESENTATIONS OR WARRANTIES OF ANY KIND WHETHER EXPRESS OR IMPLIED, WRITTEN OR ORAL, STATUTORY OR OTHERWISE, RELATED TO THE INFORMATION, INCLUDING BUT NOT LIMITED TO ITS CONDITION, QUALITY, PERFORMANCE, MERCHANTABILITY OR FITNESS FOR PURPOSE. Microchip disclaims all liability arising from this information and its use. Use of Microchip devices in life support and/or safety applications is entirely at the buyer's risk, and the buyer agrees to defend, indemnify and hold harmless Microchip from any and all damages, claims, suits, or expenses resulting from such use. No licenses are conveyed, implicitly or otherwise, under any Microchip intellectual property rights.

**Trademarks**

The Microchip name and logo, the Microchip logo, dsPIC, KEELOQ, KEELOQ logo, MPLAB, PIC, PICmicro, PICSTART, PIC<sup>32</sup> logo, rPIC and UNI/O are registered trademarks of Microchip Technology Incorporated in the U.S.A. and other countries.


FilterLab, Hampshire, HI-TECH C, Linear Active Thermistor, MXDEV, MXLAB, SEEVAL and The Embedded Control Solutions Company are registered trademarks of Microchip Technology Incorporated in the U.S.A.

Analog-for-the-Digital Age, Application Maestro, chipKIT, chipKIT logo, CodeGuard, dsPICDEM, dsPICDEM.net, dsPICworks, dsSPEAK, ECAN, ECONOMONITOR, FanSense, HI-TIDE, In-Circuit Serial Programming, ICSP, Mindi, MiWi, MPASM, MPLAB Certified logo, MPLIB, MPLINK, mTouch, Omniscient Code Generation, PICC, PICC-18, PICDEM, PICDEM.net, PICKit, PICtail, REAL ICE, rLAB, Select Mode, Total Endurance, TSHARC, UniWinDriver, WiperLock and ZENA are trademarks of Microchip Technology Incorporated in the U.S.A. and other countries.

SQTP is a service mark of Microchip Technology Incorporated in the U.S.A.

All other trademarks mentioned herein are property of their respective companies.

© 1998-2011, Microchip Technology Incorporated, Printed in the U.S.A., All Rights Reserved.

 Printed on recycled paper.

ISBN: 978-1-61341-572-6

**QUALITY MANAGEMENT SYSTEM**  
**CERTIFIED BY DNV**  
**== ISO/TS 16949:2009 ==**

*Microchip received ISO/TS-16949:2009 certification for its worldwide headquarters, design and wafer fabrication facilities in Chandler and Tempe, Arizona; Gresham, Oregon and design centers in California and India. The Company's quality system processes and procedures are for its PIC<sup>®</sup> MCUs and dsPIC<sup>®</sup> DSCs, KEELOQ<sup>®</sup> code hopping devices, Serial EEPROMs, microperipherals, nonvolatile memory and analog products. In addition, Microchip's quality system for the design and manufacture of development systems is ISO 9001:2000 certified.*



# MICROCHIP

## Worldwide Sales and Service

### AMERICAS

**Corporate Office**  
2355 West Chandler Blvd.  
Chandler, AZ 85224-6199  
Tel: 480-792-7200  
Fax: 480-792-7277  
Technical Support:  
<http://www.microchip.com/support>  
Web Address:  
[www.microchip.com](http://www.microchip.com)

**Atlanta**  
Duluth, GA  
Tel: 678-957-9614  
Fax: 678-957-1455

**Boston**  
Westborough, MA  
Tel: 774-760-0087  
Fax: 774-760-0088

**Chicago**  
Itasca, IL  
Tel: 630-285-0071  
Fax: 630-285-0075

**Cleveland**  
Independence, OH  
Tel: 216-447-0464  
Fax: 216-447-0643

**Dallas**  
Addison, TX  
Tel: 972-818-7423  
Fax: 972-818-2924

**Detroit**  
Farmington Hills, MI  
Tel: 248-538-2250  
Fax: 248-538-2260

**Indianapolis**  
Noblesville, IN  
Tel: 317-773-8323  
Fax: 317-773-5453

**Los Angeles**  
Mission Viejo, CA  
Tel: 949-462-9523  
Fax: 949-462-9608

**Santa Clara**  
Santa Clara, CA  
Tel: 408-961-6444  
Fax: 408-961-6445

**Toronto**  
Mississauga, Ontario,  
Canada  
Tel: 905-673-0699  
Fax: 905-673-6509

### ASIA/PACIFIC

**Asia Pacific Office**  
Suites 3707-14, 37th Floor  
Tower 6, The Gateway  
Harbour City, Kowloon  
Hong Kong  
Tel: 852-2401-1200  
Fax: 852-2401-3431

**Australia - Sydney**  
Tel: 61-2-9868-6733  
Fax: 61-2-9868-6755

**China - Beijing**  
Tel: 86-10-8569-7000  
Fax: 86-10-8528-2104

**China - Chengdu**  
Tel: 86-28-8665-5511  
Fax: 86-28-8665-7889

**China - Chongqing**  
Tel: 86-23-8980-9588  
Fax: 86-23-8980-9500

**China - Hangzhou**  
Tel: 86-571-2819-3187  
Fax: 86-571-2819-3189

**China - Hong Kong SAR**  
Tel: 852-2401-1200  
Fax: 852-2401-3431

**China - Nanjing**  
Tel: 86-25-8473-2460  
Fax: 86-25-8473-2470

**China - Qingdao**  
Tel: 86-532-8502-7355  
Fax: 86-532-8502-7205

**China - Shanghai**  
Tel: 86-21-5407-5533  
Fax: 86-21-5407-5066

**China - Shenyang**  
Tel: 86-24-2334-2829  
Fax: 86-24-2334-2393

**China - Shenzhen**  
Tel: 86-755-8203-2660  
Fax: 86-755-8203-1760

**China - Wuhan**  
Tel: 86-27-5980-5300  
Fax: 86-27-5980-5118

**China - Xian**  
Tel: 86-29-8833-7252  
Fax: 86-29-8833-7256

**China - Xiamen**  
Tel: 86-592-2388138  
Fax: 86-592-2388130

**China - Zhuhai**  
Tel: 86-756-3210040  
Fax: 86-756-3210049

### ASIA/PACIFIC

**India - Bangalore**  
Tel: 91-80-3090-4444  
Fax: 91-80-3090-4123

**India - New Delhi**  
Tel: 91-11-4160-8631  
Fax: 91-11-4160-8632

**India - Pune**  
Tel: 91-20-2566-1512  
Fax: 91-20-2566-1513

**Japan - Yokohama**  
Tel: 81-45-471- 6166  
Fax: 81-45-471-6122

**Korea - Daegu**  
Tel: 82-53-744-4301  
Fax: 82-53-744-4302

**Korea - Seoul**  
Tel: 82-2-554-7200  
Fax: 82-2-558-5932 or  
82-2-558-5934

**Malaysia - Kuala Lumpur**  
Tel: 60-3-6201-9857  
Fax: 60-3-6201-9859

**Malaysia - Penang**  
Tel: 60-4-227-8870  
Fax: 60-4-227-4068

**Philippines - Manila**  
Tel: 63-2-634-9065  
Fax: 63-2-634-9069

**Singapore**  
Tel: 65-6334-8870  
Fax: 65-6334-8850

**Taiwan - Hsin Chu**  
Tel: 886-3-5778-366  
Fax: 886-3-5770-955

**Taiwan - Kaohsiung**  
Tel: 886-7-536-4818  
Fax: 886-7-330-9305

**Taiwan - Taipei**  
Tel: 886-2-2500-6610  
Fax: 886-2-2508-0102

**Thailand - Bangkok**  
Tel: 66-2-694-1351  
Fax: 66-2-694-1350

### EUROPE

**Austria - Wels**  
Tel: 43-7242-2244-39  
Fax: 43-7242-2244-393

**Denmark - Copenhagen**  
Tel: 45-4450-2828  
Fax: 45-4485-2829

**France - Paris**  
Tel: 33-1-69-53-63-20  
Fax: 33-1-69-30-90-79

**Germany - Munich**  
Tel: 49-89-627-144-0  
Fax: 49-89-627-144-44

**Italy - Milan**  
Tel: 39-0331-742611  
Fax: 39-0331-466781

**Netherlands - Drunen**  
Tel: 31-416-690399  
Fax: 31-416-690340

**Spain - Madrid**  
Tel: 34-91-708-08-90  
Fax: 34-91-708-08-91

**UK - Wokingham**  
Tel: 44-118-921-5869  
Fax: 44-118-921-5820

08/02/11

## OUR CERTIFICATE

DiGi provide top-quality products and perfect service for customer worldwide through standardization, technological innovation and continuous improvement. DiGi through third-party certification, we strictly control the quality of products and services. Welcome your RFQ to

Email: [Info@DiGi-Electronics.com](mailto:Info@DiGi-Electronics.com)



Tel: +00 852-30501935

RFQ Email: [Info@DiGi-Electronics.com](mailto:Info@DiGi-Electronics.com)

DiGi is a global authorized distributor of electronic components.