

# MIC384-3BMM Datasheet

[www.digi-electronics.com](http://www.digi-electronics.com)

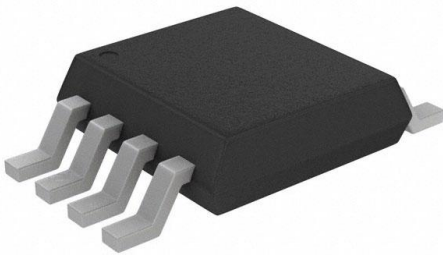

<https://www.DiGi-Electronics.com>

DiGi Electronics Part Number	MIC384-3BMM-DG
Manufacturer	<a href="#">Microchip Technology</a>
Manufacturer Product Number	MIC384-3BMM
Description	SENSOR DIGITAL -55C-125C 8MSOP
Detailed Description	Temperature Sensor Digital, Local/Remote -55°C ~ 125°C 7 b 8-MSOP

This model MIC384-3BMM is available at DiGi Electronics.

DiGi Electronics offers a global database of semiconductor and electronic component datasheets.

We welcome your inquiries regarding pricing, lead time, or other product-related questions.

 [Request a Quote](#)

 [Datasheet Search](#)



Tel: +00 852-30501935

RFQ Email: [Info@DiGi-Electronics.com](mailto:Info@DiGi-Electronics.com)

DiGi is a global authorized distributor of electronic components.

## Purchase and inquiry

Manufacturer Product Number:

MIC384-3BMM

Manufacturer:

Microchip Technology

Packaging:

Bulk

Sensor Type:

Digital, Local/Remote

Sensing Temperature - Remote:

-55°C ~ 125°C

Voltage - Supply:

2.7V ~ 5.5V

Features:

Output Switch, Programmable Limit, Shutdown Mode, Standby Mode

Test Condition:

0°C ~ 100°C (-55°C ~ 125°C)

Mounting Type:

Surface Mount

Supplier Device Package:

8-MSOP

Manufacturer:

Microchip Technology

Series:

-

Part Status:

Discontinued at Digi-Key

Sensing Temperature - Local:

-55°C ~ 125°C

Output Type:

I2C/SMBus

Resolution:

7 b

Accuracy - Highest (Lowest):

±2°C (±3°C)

Operating Temperature:

-55°C ~ 125°C

Package / Case:

8-TSSOP, 8-MSOP (0.118", 3.00mm Width)

## Environmental & Export classification

RoHS Status:

RoHS non-compliant

REACH Status:

REACH Unaffected

HTSUS:

8542.39.0060

Moisture Sensitivity Level (MSL):

1 (Unlimited)

ECCN:

EAR99



# MIC384

## Three-Zone Thermal Supervisor

### Features

- Measures Local and Two Remote Temperatures
- 2-Wire SMBus-Compatible Interface
- Programmable Thermostat Settings for All Three Zones
- Open-Drain Interrupt Output Pin
- Interrupt Mask and Status Bits
- Fault Queues to Prevent Nuisance Tripping
- Low Power Shutdown Mode
- Failsafe Response to Diode Faults
- 2.7V to 5.5V Power Supply Range
- 8-Lead SOIC and MSOP Packages

### Applications

- Desktop, Server, and Notebook Computers
- Power Supplies
- Test and Measurement Equipment
- Wireless Systems
- Networking/Datacom Hardware

### General Description

The MIC384 is a versatile digital thermal supervisor capable of measuring temperature using its own internal sensor and two inexpensive external sensors or embedded silicon diodes such as those found in the Intel Pentium III CPU. A 2-wire serial interface is provided to allow communication with either I<sup>2</sup>C or SMBus hosts. The open-drain interrupt output pin can be used as either an overtemperature alarm or a thermostatic control signal.

Interrupt mask and status bits are provided for reduced software overhead. Fault queues prevent nuisance tripping due to thermal or electrical noise. A programmable address pin permits two devices to share the bus. Alternate base addresses are available by contacting Microchip. Superior performance, low power, and small size makes the MIC384 an excellent choice for the most demanding thermal management applications.

### Package Type

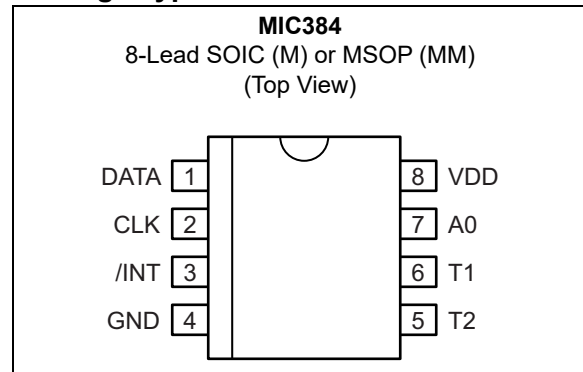

# MIC384

## Typical Application Circuit

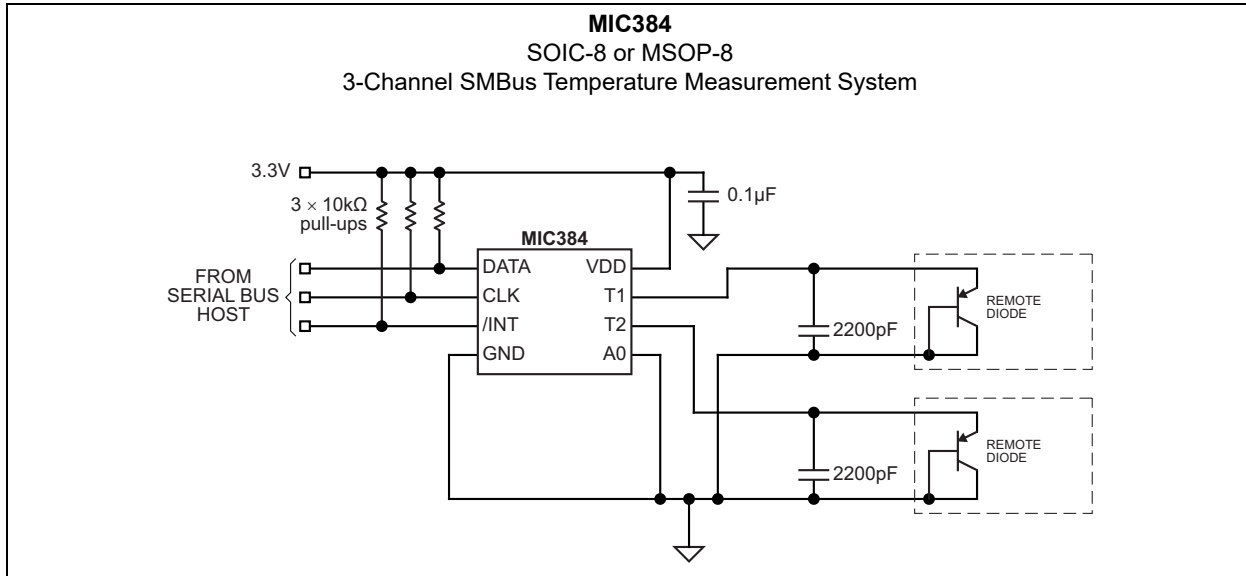

## Functional Block Diagram

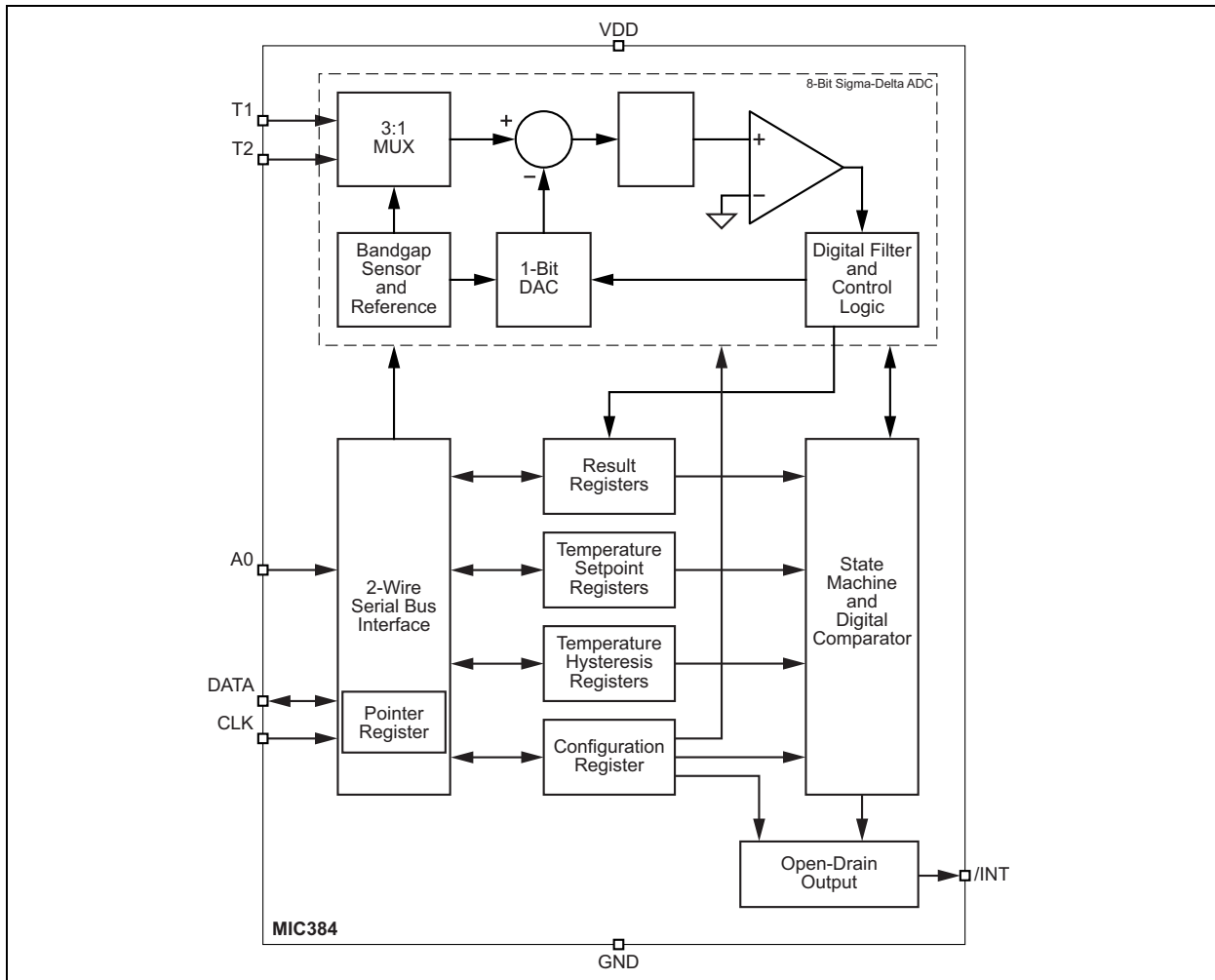

## 1.0 ELECTRICAL CHARACTERISTICS

### Absolute Maximum Ratings †

Power Supply Voltage ( $V_{DD}$ ).....	+6.0V
Voltage on Any Pin.....	-0.3V to $V_{DD} + 0.3V$
Current into Any Pin.....	$\pm 10$ mA
Power Dissipation ( $T_A = +125^\circ\text{C}$ ).....	30 mW
ESD Rating (HBM, <a href="#">Note 1</a> ).....	TBD kV
ESD Rating (MM, <a href="#">Note 1</a> ).....	TBDV

### Operating Ratings ‡

Power Supply Voltage ( $V_{DD}$ ).....	+2.7V to +5.5V
--	----------------

**† Notice:** Stresses above those listed under “Absolute Maximum Ratings” may cause permanent damage to the device. This is a stress rating only and functional operation of the device at those or any other conditions above those indicated in the operational sections of this specification is not intended. Exposure to maximum rating conditions for extended periods may affect device reliability.

**‡ Notice:** The device is not guaranteed to function outside its operating ratings. Final test on outgoing product is performed at  $T_A = +25^\circ\text{C}$ .

**Note 1:** Devices are ESD sensitive. Handling precautions are recommended. Human body model, 1.5 k $\Omega$  in series with 100 pF.

# MIC384

## ELECTRICAL CHARACTERISTICS

**Electrical Characteristics:**  $2.7V \leq V_{DD} \leq 5.5V$ ;  $T_A = +25^\circ C$ , unless noted. **Bold** values indicate  $-55^\circ C \leq T_A \leq +125^\circ C$ , unless noted. [Note 1](#)

Parameters	Symbol	Min.	Typ.	Max.	Units	Conditions
<b>Power Supply</b>						
Supply Current	$I_{DD}$	—	350	<b>750</b>	$\mu A$	/INT, open, A0 = $V_{DD}$ or GND, CLK = DATA = high, normal mode
		—	3	—		/INT, open, A0 = $V_{DD}$ or GND, shutdown mode, CLK = 100 kHz
		—	1	<b>10</b>		/INT, open, A0 = $V_{DD}$ or GND, shutdown mode, CLK = DATA = high
Power-on Reset Time, <a href="#">Note 2</a>	$t_{POR}$	—	—	<b>200</b>	$\mu s$	$V_{DD} > V_{POR}$
Power-on Reset Voltage	$V_{POR}$	—	2.0	2.7	V	All registers reset to default values; A/D conversions initiated
Power-on Reset Hysteresis Voltage	$V_{HYST}$	—	250	—	mV	—
<b>Temperature-to-Digital Converter Characteristics</b>						
Local Temperature Accuracy, <a href="#">Note 1</a> , <a href="#">Note 3</a>	—	—	$\pm 1$	<b><math>\pm 2</math></b>	$^\circ C$	$0^\circ C \leq T_A \leq +100^\circ C$ , /INT open, $3V \leq V_{DD} \leq 3.6V$
		—	$\pm 2$	<b><math>\pm 3</math></b>		$-55^\circ C \leq T_A \leq +125^\circ C$ , /INT open, $3V \leq V_{DD} \leq 3.6V$
Remote Temperature Accuracy, <a href="#">Note 1</a> , <a href="#">Note 3</a> , <a href="#">Note 4</a>	—	—	$\pm 1$	<b><math>\pm 3</math></b>	$^\circ C$	$0^\circ C \leq T_D \leq +100^\circ C$ , /INT open, $3V \leq V_{DD} \leq 3.6V$ , $0^\circ C \leq T_A \leq +85^\circ C$
		—	$\pm 2$	<b><math>\pm 5</math></b>		$-55^\circ C \leq T_D \leq +125^\circ C$ , /INT open, $3V \leq V_{DD} \leq 3.6V$ , $0^\circ C \leq T_A \leq +85^\circ C$
Local Zone Conversion Time	$t_{CONV0}$	—	50	<b>80</b>	ms	<a href="#">Note 2</a> , <a href="#">Note 5</a>
Remote Zone Conversion Time	$t_{CONV1}$	—	100	<b>160</b>	ms	<a href="#">Note 2</a> , <a href="#">Note 5</a>
<b>Remote Temperature Input, T1</b>						
Current into External Diode, <a href="#">Note 2</a>	$I_F$	—	224	<b>400</b>	$\mu A$	T1 or T2 forced to 1.5V, high level
		<b>7.5</b>	14	—		Low level
<b>Address Input (A0)</b>						
Low Input Voltage	$V_{IL}$	—	—	<b>0.6</b>	V	$2.7V \leq V_{DD} \leq 5.5V$
High Input Voltage	$V_{IH}$	<b>2.0</b>	—	—	V	$2.7V \leq V_{DD} \leq 5.5V$
Input Capacitance	$C_{IN}$	—	10	—	pF	—
Input Current	$I_{LEAK}$	—	$\pm 0.01$	$\pm 1$	$\mu A$	—

## ELECTRICAL CHARACTERISTICS (CONTINUED)

**Electrical Characteristics:**  $2.7V \leq V_{DD} \leq 5.5V$ ;  $T_A = +25^\circ C$ , unless noted. **Bold** values indicate  $-55^\circ C \leq T_A \leq +125^\circ C$ , unless noted. [Note 1](#)

Parameters	Symbol	Min.	Typ.	Max.	Units	Conditions
<b>Serial Data I/O Pin, DATA</b>						
Low Output Voltage, <a href="#">Note 6</a>	$V_{OL}$	—	—	<b>0.4</b>	V	$I_{OL} = 3 \text{ mA}$
		—	—	<b>0.8</b>		$I_{OL} = 6 \text{ mA}$
Low Input Voltage	$V_{IL}$	—	—	<b><math>0.3V_{DD}</math></b>	V	$2.7V \leq V_{DD} \leq 5.5V$
High Input Voltage	$V_{IH}$	<b><math>0.7V_{DD}</math></b>	—	—	V	$2.7V \leq V_{DD} \leq 5.5V$
Input Capacitance	$C_{IN}$	—	10	—	pF	—
Input Current	$I_{LEAK}$	—	$\pm 0.01$	$\pm 1$	$\mu A$	—
<b>Serial Clock Input, CLK</b>						
Low Input Voltage	$V_{IL}$	—	—	<b><math>0.3V_{DD}</math></b>	V	$2.7V \leq V_{DD} \leq 5.5V$
High Input Voltage	$V_{IH}$	<b><math>0.7V_{DD}</math></b>	—	—	V	$2.7V \leq V_{DD} \leq 5.5V$
Input Capacitance	$C_{IN}$	—	10	—	pF	—
Input Current	$I_{LEAK}$	—	$\pm 0.01$	$\pm 1$	$\mu A$	—
<b>Status Output (/INT)</b>						
Low Output Voltage, <a href="#">Note 6</a>	$V_{OL}$	—	—	<b>0.4</b>	V	$I_{OL} = 3 \text{ mA}$
		—	—	<b>0.8</b>	V	$I_{OL} = 6 \text{ mA}$
Interrupt Propagation Delay, <a href="#">Note 2</a> , <a href="#">Note 5</a>	$t_{INT}$	—	—	<b><math>t_{CONV} + 1</math></b>	$\mu s$	From $TEMP > T_{SET}$ or $TEMPx < T_{HYSTx}$ to $INT < V_{OL}$ , $FQ = 00$ , $R_{PULLUP} = 10 \text{ k}\Omega$
Interrupt Reset Propagation Delay, <a href="#">Note 2</a>	$t_{nINT}$	—	—	<b>1</b>	$\mu s$	From any register read to $/INT > V_{OH}$ , $FQ = 00$ , $R_{PULLUP} = 10 \text{ k}\Omega$
Default $T_{SET0}$ Value	$T_{SET0}$	81	81	81	$^\circ C$	$t_{POR}$ after $V_{DD} > V_{POR}$
Default $T_{HYST0}$ Value	$T_{HYST0}$	76	76	76	$^\circ C$	$t_{POR}$ after $V_{DD} > V_{POR}$
Default $T_{SET1}$ Value	$T_{SET1}$	97	97	97	$^\circ C$	$t_{POR}$ after $V_{DD} > V_{POR}$
Default $T_{HYST1}$ Value	$T_{HYST1}$	92	92	92	$^\circ C$	$t_{POR}$ after $V_{DD} > V_{POR}$
Default $T_{SET2}$ Value	$T_{SET2}$	97	97	97	$^\circ C$	$t_{POR}$ after $V_{DD} > V_{POR}$
Default $T_{HYST2}$ Value	$T_{HYST2}$	92	92	92	$^\circ C$	$t_{POR}$ after $V_{DD} > V_{POR}$

# MIC384

## ELECTRICAL CHARACTERISTICS (CONTINUED)

**Electrical Characteristics:**  $2.7V \leq V_{DD} \leq 5.5V$ ;  $T_A = +25^\circ C$ , unless noted. **Bold** values indicate  $-55^\circ C \leq T_A \leq +125^\circ C$ , unless noted. [Note 1](#)

Parameters	Symbol	Min.	Typ.	Max.	Units	Conditions
<b>Serial Interface Timing (Note 2)</b>						
CLK (Clock) Period	$t_1$	<b>2.5</b>	—	—	$\mu s$	—
Data-In Set-Up Time to CLK High	$t_2$	<b>100</b>	—	—	ns	—
Data-Out Stable after CLK Low	$t_3$	<b>0</b>	—	—	ns	—
Data-Low Set-Up Time to CLK Low	$t_4$	<b>100</b>	—	—	ns	Start Condition
Data-High Hold Time after CLK High	$t_5$	<b>100</b>	—	—	ns	Stop Condition

- Note 1:** Final test on outgoing product is performed at  $T_A = +TBD^\circ C$ .
- 2:** Guaranteed by design over the operating temperature range. Not 100% production tested.
- 3:** Accuracy specification does not include quantization noise, which may be up to  $\pm 1/2$  LSB ( $\pm 0.5^\circ C$ ).
- 4:**  $T_D$  is the temperature of the remote diode junction. Testing is performed using a single unit of one of the transistors listed in [Table 5-1](#).
- 5:**  $t_{CONV} = t_{CONV0} + (2 \times t_{CONV1}) \times t_{CONV0}$  is the conversion time for the local zone;  $t_{CONV1}$  is the conversion time for the remote zone.
- 6:** Current into this pin will result in self-heating of the MIC384. Sink current should be minimized for best accuracy.

**TEMPERATURE SPECIFICATIONS**

Parameters	Sym.	Min.	Typ.	Max.	Units	Conditions
<b>Temperature Ranges</b>						
Storage Temperature	$T_S$	-65	—	+150	°C	—
Ambient Temperature Range	$T_A$	-55	—	+125	°C	—
Lead Temperature Soldering	—	—	—	+220 ±5	°C	Vapor Phase, 60 sec.
		—	—	+235 ±5	°C	Infrared, 15 sec.
<b>Package Thermal Resistances</b>						
SOIC-8	$\theta_{JA}$	—	152	—	°C/W	—
MSOP-8	$\theta_{JA}$	—	206	—	°C/W	—

**Note 1:** The maximum allowable power dissipation is a function of ambient temperature, the maximum allowable junction temperature and the thermal resistance from junction to air (i.e.,  $T_A$ ,  $T_J$ ,  $\theta_{JA}$ ). Exceeding the maximum allowable power dissipation will cause the device operating junction temperature to exceed the maximum +150°C rating. Sustained junction temperatures above +150°C can impact the device reliability.

# MIC384

## 2.0 PIN DESCRIPTIONS

The descriptions of the pins are listed in [Table 2-1](#).

**TABLE 2-1: PIN FUNCTION TABLE**

Pin Number	Symbol	Description
1	DATA	Digital I/O: Open-drain. Serial data input/output.
2	CLK	Digital Input: The host provides the serial bit clock on this input.
3	/INT	Digital Output: Open-drain. Interrupt or thermostat output.
4	GND	Ground: Power and signal return for all IC functions.
5	T2	Analog Input: Connection to remote temperature sensor (diode junction).
6	T1	Analog Input: Connection to remote temperature sensor (diode junction).
7	A0	Digital Input: Client address selection input. See <a href="#">Table 3-1</a> .
8	VDD	Analog Input: Power supply input to the IC.

### Timing Diagram

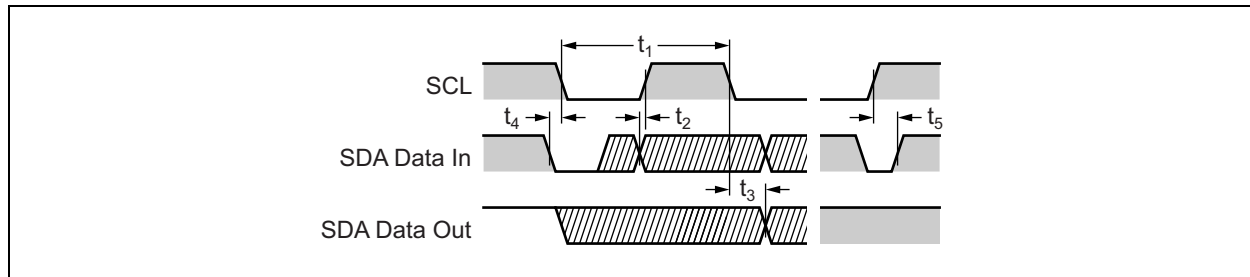

**FIGURE 2-1:** Serial Interface Timing.

## 3.0 FUNCTIONAL DESCRIPTION

### 3.1 Pin Descriptions

#### 3.1.1 VDD

Power supply input. See [Table 2-1](#).

#### 3.1.2 GND

Ground return for all MIC384 functions.

#### 3.1.3 CLK

Clock input to the MIC384 from the two-wire serial bus. The clock signal is provided by the host and is shared by all devices on the bus.

#### 3.1.4 DATA

Serial data I/O pin that connects to the two-wire serial bus. DATA is bi-directional and has an open-drain output driver. An external pull-up resistor or current source somewhere in the system is necessary on this line. This line is shared by all devices on the bus.

#### 3.1.5 A0

This input sets the least significant bit of the MIC384's 7-bit client address. The six most-significant bits are fixed and are determined by the part number ordered. Each MIC384 will only respond to its own unique client address, allowing up to eight MIC384s to share a single bus. A match between the MIC384's address and the address specified in the serial bit stream must be made to initiate communication. A0 should be tied directly to VDD or ground. See [Temperature Measurement](#) and [Power-On](#) for more information. A0 determines the client address as shown in [Table 3-1](#).

**TABLE 3-1: MIC384 CLIENT ADDRESS SETTINGS**

Part Number	A0 Inputs	Binary Address	Hex Address
MIC384-0	0	100 1000 <sub>b</sub>	48 <sub>h</sub>
	1	100 1001 <sub>b</sub>	49 <sub>h</sub>
MIC384-1	0	100 1010 <sub>b</sub>	4A <sub>h</sub>
	1	100 1011 <sub>b</sub>	4B <sub>h</sub>
MIC384-2	0	100 1100 <sub>b</sub>	4C <sub>h</sub>
	1	100 1101 <sub>b</sub>	4D <sub>h</sub>
MIC384-3	0	100 1110 <sub>b</sub>	4E <sub>h</sub>
	1	100 1111 <sub>b</sub>	4F <sub>h</sub>

#### 3.1.6 /INT

Temperature events are indicated to external circuitry via this output. Operation of the /INT output is controlled by the MODE and IM bits in the MIC384's configuration register. See [Comparator and Interrupt Modes](#). This output is open-drain and may be wire-OR'ed with other open-drain signals. Most

systems will require a pull-up resistor or current source on this pin. If the IM bit in the configuration register is set, it prevents the /INT output from sinking current. In I<sup>2</sup>C and SMBus systems, the IM bit is therefore an interrupt mask bit.

#### 3.1.7 T1 AND T2

The T1 and T2 pins connect to off-chip PN diode junctions for monitoring the junction temperature at remote locations. The remote diodes may be embedded thermal sensing junctions in integrated circuits so equipped (such as Intel's Pentium III), or discrete 2N3906-type bipolar transistors with base and collector tied together.

## 3.2 Temperature Measurement

The temperature-to-digital converter is built around a switched current source and an eight-bit analog-to-digital converter. Each diode's temperature is calculated by measuring its forward voltage drop at two different current levels. An internal multiplexer directs the current source's output to either the internal or one of the external diode junctions. The MIC384 uses two's-complement data to represent temperatures. If the MSB of a temperature value is zero, the temperature is zero or positive. If the MSB is one, the temperature is negative. More detail on this is given in the [Temperature Data Format](#) section. A temperature event results if the value in either of the temperature result registers (TEMPx) becomes greater than the value in the corresponding temperature setpoint register (T\_SETx). Another temperature event occurs if and when the measured temperature subsequently falls below the temperature hysteresis setting in T\_HYSTx.

During normal operation the MIC384 continuously performs temperature-to-digital conversions, compares the results against the setpoint and hysteresis registers, and updates the states of /INT and the status bits accordingly. The remote zones are converted first, followed by the local zone (T1 > T2 > LOCAL). The states of /INT and the status bits are updated after each measurement is taken.





# MIC384

## 3.5 Temperature Data Format

The LSB of each register represents one degree Centigrade. The values are in a two's complement format, wherein the most significant bit (D7), represents the sign: zero for positive temperatures and one for negative temperatures. [Table 3-3](#) shows examples of the data format used by the MIC384 for temperatures.

**TABLE 3-3: DIGITAL TEMPERATURE FORMAT**

Temperature	Binary	Hex
+125°C	0111 1101 <sub>b</sub>	7D <sub>h</sub>
+100°C	0110 0100 <sub>b</sub>	64 <sub>h</sub>
+25°C	0001 1001 <sub>b</sub>	19 <sub>h</sub>
+1.0°C	0000 0001 <sub>b</sub>	01 <sub>h</sub>
0°C	0000 0000 <sub>b</sub>	00 <sub>h</sub>
-1.0°C	1111 1111 <sub>b</sub>	FF <sub>h</sub>
-25°C	1110 0111 <sub>b</sub>	E7 <sub>h</sub>
-40°C	1101 1000 <sub>b</sub>	D8 <sub>h</sub>
-55°C	1100 1001 <sub>b</sub>	C9 <sub>h</sub>

## 3.6 A/D Converter Timing

Whenever the MIC384 is not in its low power shutdown mode, the internal A/D converter (ADC) attempts to make continuous conversions unless interrupted by a bus transaction accessing the MIC384.

Upon powering up or coming out of shutdown mode, the ADC will begin acquiring temperature data starting with the first external zone (zone 1), then the second external zone (zone 2), and finally the internal zone (zone 0). Results for zone 1 will be valid after  $t_{CONV1}$ , results for zone two will be ready after another  $t_{CONV1}$ , and for the local zone  $t_{CONV0}$  later. [Figure 3-4](#) shows this behavior. The conversion time is twice as long for external conversions as it is for internal conversions. This allows the use of a filter capacitor on T1 and/or T2 without a loss of accuracy due to the resulting longer settling times.

Upon powering up, coming out of shutdown mode, or resuming operation following a serial bus transaction, the ADC will begin acquiring temperature data with the first external zone (zone 1), followed by the second external zone (zone 2), and then the internal zone (zone 0). If the ADC is interrupted by a serial bus transaction, it will restart the conversion that was interrupted and then continue in the normal sequence. This sequence will repeat indefinitely until the MIC384 is shut down, powered off, or is interrupted by a serial bus transaction as described above.

## 3.7 Power-On

When power is initially applied, the MIC384's internal registers are set to their default states. Also at this time, the level on the address input, A0, is read to establish the device's client address. The MIC384's power-up default state can be summarized as follows:

- Normal Mode operation (i.e., part is not in shutdown)
- /INT function is set to Comparator Mode
- Fault Queue depth = 1 (FQ = 00)
- Interrupts are enabled (IM = 0)
- T\_SET0 = 81°C; T\_HYST0 = 76°C
- T\_SET1 = 97°C; T\_HYST1 = 92°C
- T\_SET2 = 97°C; T\_HYST2 = 92°C
- Initialized to recognize overtemperature faults

## 3.8 Comparator and Interrupt Modes

Depending on the setting of the MODE bit in the configuration register, the /INT output will behave either as an interrupt request signal or a thermostatic control signal. Thermostatic operation is known as comparator mode. The /INT output is asserted when the measured temperature, as reported in any of the TEMPx registers, exceeds the threshold programmed into the corresponding T\_SETx register for the number of conversions specified by [Fault Queue](#). In comparator mode, /INT will remain asserted and the status bit(s) will remain high unless and until the measured temperature falls below the value in the T\_HYSTx register for Fault\_Queue conversions. No action on the part of the host is required for operation in comparator mode. Note that entering shutdown mode will not affect the state of /INT when the device is in comparator mode.

In interrupt mode, once a temperature event has caused a status bit to be set and the /INT output to be asserted, they will not be automatically de-asserted when the measured temperature falls below T\_HYSTx. They can only be de-asserted by reading any of the MIC384's internal registers or by putting the device into shutdown mode. If the most recent temperature event was an overtemperature condition, Sx will not be set again, and /INT cannot be reasserted, until the device has detected that TEMPx is less than T\_HYSTx. Similarly, if the most recent temperature event was an undertemperature condition, Sx will not be set again, and /INT cannot be reasserted, until the device has detected that TEMPx is greater than T\_SETx. This keeps the internal logic of the MIC384 backward compatible with that of the LM75 and similar devices. In both modes, the MIC384 will be responsive to overtemperature events at power-up. See [Interrupt Generation](#) below.

### 3.9 Shutdown Mode

Setting the SHDN bit in the configuration register halts the otherwise continuous conversions by the A/D converter. The MIC384's power consumption drops to 1  $\mu$ A typical in shutdown mode. All registers may be read from or written to while in shutdown mode. Serial bus activity will slightly increase the part's power consumption.

Entering shutdown mode will not affect the state of /INT when the device is in comparator mode (MODE = 0). It will retain its state until after the device exits shutdown mode and resumes A/D conversions.

However, if the device is shut down while in interrupt mode, the /INT pin will be unconditionally de-asserted and the internal latches holding the interrupt status will be cleared. Therefore, no interrupts will be generated while the MIC384 is in shutdown mode, and the interrupt status will not be retained. Because entering shutdown mode stops A/D conversions, the MIC384 is incapable of detecting or reporting temperature events of any kind while in shutdown. Diode faults require one or more A/D conversion cycles to be recognized, and therefore will not be reported either while the device is in shutdown (see [Diode Faults](#) for more information).

### 3.10 Fault\_Queue

Fault queues (programmable digital filters) are provided in the MIC384 to prevent false tripping due to thermal or electrical noise. The two bits in CONFIG[4:3] set the depth of Fault\_Queue. Fault\_Queue then determines the number of consecutive temperature events ( $TEMPx > T\_SETx$ , or  $TEMPx < T\_HYSTx$ ) that must occur in order for the condition to be considered valid. There are separate fault queues for each zone. As an example, assume the part is in comparator mode, and CONFIG[4:3] is programmed with  $10_b$ . The measured temperature in zone one would have to exceed  $T\_SET1$  for four consecutive A/D conversions before /INT would be asserted or the S1 status bit set. Similarly, TEMP1 would then have to be less than  $T\_HYST1$  for four consecutive conversions before /INT would be reset. Like any filter, the fault queue function also has the effect of delaying the detection of temperature events. In this example, it would take  $4 \times t_{CONV}$  to detect a temperature event. The depth of Fault\_Queue vs. D[4:3] of the configuration register is shown in [Table 3-4](#).

**TABLE 3-4: FAULT\_QUEUE DEPTH SETTINGS**

CONFIG[4:3]	Fault_Queue Depth
00	1 Conversion (default)
01	2 Conversions
10	4 Conversions
11	6 Conversions

### 3.11 Interrupt Generation

Assuming the MIC384 is in interrupt mode and interrupts are enabled, there are seven different conditions that will cause the MIC384 to set one of the status bits (S0, S1, or S2) in CONFIG and assert its /INT output. These conditions are listed in [Table 3-5](#). When a temperature event occurs, the corresponding status bit will be set in CONFIG. This action cannot be masked. However, a temperature event will only generate an interrupt signal on /INT if it is specifically enabled by the interrupt mask bit (IM = 0 in CONFIG). Following an interrupt, the host should read the contents of the configuration register to confirm that the MIC384 was the source of the interrupt. A read operation on any register will cause /INT to be de-asserted. This is shown in [Figure 3-5](#). The status bits will only be cleared once CONFIG has been read.

Because temperature-to-digital conversions continue while /INT is asserted, the measured temperature could change between the MIC384's assertion of /INT and the host's response. It is good practice for the interrupt service routine to read the value in TEMPx, to verify that the overtemperature or undertemperature condition still exists. In addition, more than one temperature event may have occurred simultaneously or in rapid succession between the assertion of /INT and servicing of the MIC384 by the host. The interrupt service routine should allow for this eventuality. Keep in mind that clearing the status bits and de-asserting /INT is not sufficient to allow further interrupts to occur. TEMPx must become less than  $T\_HYSTx$  if the last event was an overtemperature condition, or greater than  $T\_SETx$  if the last event was an undertemperature condition, before /INT can be asserted again.

Putting the device into shutdown mode will de-assert /INT and clear the status bits (S0, S1, and S2). This should not be done before completing the appropriate interrupt service routine(s).

# MIC384

**TABLE 3-5: MIC384 TEMPERATURE EVENTS**

Event	Condition (Note 1)	MIC384 Response (Note 2)
High temperature, local	TEMP0 > T_SET0	Set S0 in CONFIG, assert /INT
High temperature, remote zone 1	TEMP1 > T_SET1	Set S1 in CONFIG, assert /INT
High temperature, remote zone 2	TEMP2 > T_SET2	Set S2 in CONFIG, assert /INT
Low temperature, local	TEMP0 < T_HYST0	Set S0 in CONFIG, assert /INT
Low temperature, remote zone 1	TEMP1 < T_HYST1	Set S1 in CONFIG, assert /INT
Low temperature, remote zone 2	TEMP2 < T_HYST2	Set S2 in CONFIG, assert /INT
Diode fault	T1 or T2 open or shorted to VDD or GND	Set S1 and/or S2 in CONFIG, assert /INT, <a href="#">Note 3</a>

**Note 1:** Condition must be true for FAULT\_QUEUE conversion to be recognized.

**Note 2:** Assumes interrupts enabled.

**Note 3:** Assumes the T\_SET1 and T\_SET2 are set to any value less than +127°C = 7F<sub>h</sub> = 0111 1111<sub>b</sub>.

## 3.12 Polling

The MIC384 may either be polled by the host, or request the host's attention via the /INT pin. In the case of polled operation, the host periodically reads the contents of CONFIG to check the state of the status bits. The act of reading CONFIG clears the status bits. If more than one event that sets a given status bit occurs before the host polls the MIC384, only the fact that at least one such event has occurred will be apparent to the host. For polled systems, the interrupt mask bit should be set (IM = 1). This will disable interrupts from the MIC384 and prevent the /INT pin from sinking current.

**4.0 REGISTER SET AND PROGRAMMER'S MODEL****TABLE 4-1: INTERNAL REGISTER SET**

Name	Description	Command Byte	Operation	Power-Up Default
TEMP0	Measured temperature, local zone	00 <sub>h</sub>	8-bit read only	00 <sub>h</sub> (0°C), <a href="#">Note 1</a>
CONFIG	Configuration register	01 <sub>h</sub>	8-bit read/write	00 <sub>h</sub> , <a href="#">Note 2</a>
T_HYST0	Hysteresis setting, local zone	02 <sub>h</sub>	8-bit read/write	4C <sub>h</sub> (+76°C)
T_SET0	Temperature setpoint, local zone	03 <sub>h</sub>	8-bit read/write	51 <sub>h</sub> (+81°C)
TEMP1	Measured temperature, zone 1	10 <sub>h</sub>	8-bit read/write	00 <sub>h</sub> (0°C), <a href="#">Note 1</a>
T_HYST1	Hysteresis setting, zone 1	12 <sub>h</sub>	8-bit read/write	5C <sub>h</sub> (+92°C)
T_SET1	Temperature setpoint, zone 1	13 <sub>h</sub>	8-bit read/write	61 <sub>h</sub> (+97°C)
TEMP2	Measured temperature, zone 2	20 <sub>h</sub>	8-bit read/write	00 <sub>h</sub> (0°C), <a href="#">Note 1</a>
T_HYST2	Hysteresis setting, zone 2	22 <sub>h</sub>	8-bit read/write	5C <sub>h</sub> (+92°C)
T_SET2	Temperature setpoint, zone 2	23 <sub>h</sub>	8-bit read/write	61 <sub>h</sub> (+97°C)

**Note 1:** TEMP<sub>x</sub> will contain measured temperature data after the completion of one conversion cycle.

**2:** After the first Fault\_Queue conversions are complete, status bits will be set if TEMP<sub>x</sub> > T\_SET<sub>x</sub>.

**4.1 Detailed Register Descriptions****TABLE 4-2: CONFIGURATION REGISTER (CONFIG) 8-BIT READ/WRITE**

D[7]	D[6]	D[5]	D[4]	D[3]	D[2]	D[1]	D[0]
Read Only	Read Only	Read Only	Read/Write		Read/Write	Read/Write	Read/Write
Local Status (S0)	Remote Status (S1)	/CRIT Status (CRIT1)	Fault Queue Depth (FQ[1:0])		Interrupt Mask (IM)	CMP/INT Mode (MODE)	Shutdown (SHDN)
Bits	Function			Operation			
S0	Local interrupt status (read only)			1 = event occurred, 0 = no event.			
S1	Remote interrupt status (read only)			1 = event occurred, 0 = no event.			
CRIT1	Remote overtemperature status (read only)			1 = overtemperature, 0 = no event.			
FQ[1:0]	Fault_Queue depth			00 = 1 conversion, 01 = 2 conversions, 10 = 4 conversions, 11 = 6 conversions			
IM	Interrupt mask			1 = disabled, 0 = interrupts enabled.			
MODE	Comparator/interrupt mode selection for /INT pin			1 = interrupt mode, 0 = comparator mode.			
SHDN	Normal/shutdown operating mode selection			1 = shutdown, 0 = normal.			

CONFIG Power-Up Value: 0000 0000<sub>b</sub> = 00<sub>h</sub>

- Not in shutdown mode
- Comparator mode
- /INT = active low
- Fault\_Queue depth = 1
- Interrupts enabled.
- No temperature events pending

CONFIG Command Byte Value: 0000 0001<sub>b</sub> = 01<sub>h</sub>

Note that following the first Fault\_Queue conversions, one or more of the status bits may be set.

# MIC384

**TABLE 4-3: LOCAL TEMPERATURE RESULT (TEMP0), 8-BIT READ ONLY**

D[7]	D[6]	D[5]	D[4]	D[3]	D[2]	D[1]	D[0]
MSB	Bit 6	Bit 5	Bit 4	Bit 3	Bit 2	Bit 1	LSB
Temperature Data from ADC							
Bits	Function			Operation			
D[7:0]	Measured temperature data for the local zone, <a href="#">Note 1</a>			Read only			

**Note 1:** Each LSB represents one degree Centigrade. The values are in a two's complement format such that 0°C is reported as 0000 0000<sub>b</sub>. See [Temperature Data Format](#) for more details.

TEMP0 Power-Up Value: 0000 0000<sub>b</sub> = 00<sub>h</sub> (0°C)

TEMP0 Command Byte Value: 0000 0000<sub>b</sub> = 00<sub>h</sub>

Please note that TEMP0 will contain measured temperature data after the completion of one conversion.

**TABLE 4-4: LOCAL TEMPERATURE HYSTERESIS (T\_HYST0), 8-BIT READ/WRITE**

D[7]	D[6]	D[5]	D[4]	D[3]	D[2]	D[1]	D[0]
MSB	Bit 6	Bit 5	Bit 4	Bit 3	Bit 2	Bit 1	LSB
Local Temperature Hysteresis Setting							
Bits	Function			Operation			
D[7:0]	Local temperature hysteresis setting, <a href="#">Note 1</a>			Read/Write			

**Note 1:** Each LSB represents one degree Centigrade. The values are in a two's complement format such that 0°C is reported as 0000 0000<sub>b</sub>. See [Temperature Data Format](#) for more details.

T\_HYST0 Power-Up Value: 0100 1100<sub>b</sub> = 4C<sub>h</sub> (+76°C)

T\_HYST0 Command Byte Value: 0000 0010<sub>b</sub> = 02<sub>h</sub>

**TABLE 4-5: LOCAL TEMPERATURE SETPOINT (T\_SET0), 8-BIT READ/WRITE**

D[7]	D[6]	D[5]	D[4]	D[3]	D[2]	D[1]	D[0]
MSB	Bit 6	Bit 5	Bit 4	Bit 3	Bit 2	Bit 1	LSB
Local temperature setpoint							
Bits	Function			Operation			
D[7:0]	Local temperature setpoint, <a href="#">Note 1</a>			Read/Write			

**Note 1:** Each LSB represents one degree Centigrade. The values are in a two's complement format such that 0°C is reported as 0000 0000<sub>b</sub>. See [Temperature Data Format](#) for more details.

T\_SET0 Power-Up Value: 0101 0001<sub>b</sub> = 51<sub>h</sub> (+81°C)

T\_SET0 Command Byte Value: 0000 0011<sub>b</sub> = 03<sub>h</sub>

**TABLE 4-6: REMOTE ZONE 1 TEMPERATURE RESULT (TEMP1), 8-BIT READ ONLY**

D[7]	D[6]	D[5]	D[4]	D[3]	D[2]	D[1]	D[0]
MSB	Bit 6	Bit 5	Bit 4	Bit 3	Bit 2	Bit 1	LSB
Remote zone 1 temperature data from ADC, <a href="#">Note 1</a>							
Bits	Function			Operation			
D[7:0]	Measured temperature data for remote zone 1, <a href="#">Note 1</a>			Read Only			

**Note 1:** Each LSB represents one degree Centigrade. The values are in a two's complement format such that 0°C is reported as 0000 0000<sub>b</sub>. See [Temperature Data Format](#) for more details.

TEMP1 Power-Up Value: 0000 0000<sub>b</sub> = 00<sub>h</sub> (0°C)

TEMP1 Command Byte Value: 0001 0000<sub>b</sub> = 10<sub>h</sub>

Please note that TEMP1 will contain measured temperature data for the selected zone after the completion of one conversion.

**TABLE 4-7: REMOTE ZONE 1 TEMPERATURE HYSTERESIS (T\_HYST1), 8-BIT READ/WRITE**

D[7]	D[6]	D[5]	D[4]	D[3]	D[2]	D[1]	D[0]
MSB	Bit 6	Bit 5	Bit 4	Bit 3	Bit 2	Bit 1	LSB
Remote zone 1 temperature hysteresis							
Bits	Function			Operation			
D[7:0]	Remote zone 1 temperature hysteresis s, <a href="#">Note 1</a>			Read/Write			

**Note 1:** Each LSB represents one degree Centigrade. The values are in a two's complement format such that 0°C is reported as 0000 0000<sub>b</sub>. See [Temperature Data Format](#) for more details.

T\_HYST1 Power-Up Value: 0101 1100<sub>b</sub> = 5C<sub>h</sub> (+92°C)

T\_HYST1 Command Byte Value: 0001 0010<sub>b</sub> = 12<sub>h</sub>

**TABLE 4-8: REMOTE ZONE 1 TEMPERATURE SETPOINT (T\_SET1), 8-BIT READ/WRITE**

D[7]	D[6]	D[5]	D[4]	D[3]	D[2]	D[1]	D[0]
MSB	Bit 6	Bit 5	Bit 4	Bit 3	Bit 2	Bit 1	LSB
Remote zone 1 temperature setpoint							
Bits	Function			Operation			
D[7:0]	Remote zone 1 temperature setpoint, <a href="#">Note 1</a>			Read/Write			

**Note 1:** Each LSB represents one degree Centigrade. The values are in a two's complement format such that 0°C is reported as 0000 0000<sub>b</sub>. See [Temperature Data Format](#) for more details.

T\_SET1 Power-Up Value: 0110 0001<sub>b</sub> = 61<sub>h</sub> (+97°C)

T\_SET1 Command Byte Value: 0001 0011<sub>b</sub> = 13<sub>h</sub>

# MIC384

**TABLE 4-9: REMOTE ZONE 2 TEMPERATURE RESULT (TEMP2), 8-BIT READ ONLY**

D[7]	D[6]	D[5]	D[4]	D[3]	D[2]	D[1]	D[0]
MSB	Bit 6	Bit 5	Bit 4	Bit 3	Bit 2	Bit 1	LSB
Remote zone 2 temperature data from ADC							
Bits	Function			Operation			
D[7:0]	Measured temperature data for remote zone 2, <a href="#">Note 1</a>			Read only			

**Note 1:** Each LSB represents one degree Centigrade. The values are in a two's complement format such that 0°C is reported as 0000 0000<sub>b</sub>. See [Temperature Data Format](#) for more details.

TEMP2 Power-Up Value: 0000 0000<sub>b</sub> = 00<sub>h</sub> (0°C)

TEMP2 Command Byte Value: 0010 0000<sub>b</sub> = 20<sub>h</sub>

Please note that TEMP2 will contain measured temperature data for the selected zone after the completion of one conversion.

**TABLE 4-10: REMOTE ZONE 2 HYSTERESIS (T\_HYST2), 8-BIT READ/WRITE**

D[7]	D[6]	D[5]	D[4]	D[3]	D[2]	D[1]	D[0]
MSB	Bit 6	Bit 5	Bit 4	Bit 3	Bit 2	Bit 1	LSB
Remote zone 2 temperature hysteresis setting							
Bits	Function			Operation			
D[7:0]	Remote zone 2 temperature hysteresis setting, <a href="#">Note 1</a>			Read/Write			

**Note 1:** Each LSB represents one degree Centigrade. The values are in a two's complement format such that 0°C is reported as 0000 0000<sub>b</sub>. See [Temperature Data Format](#) for more details.

T\_HYST2 Power-Up Value: 0101 1100<sub>b</sub> = 5C<sub>h</sub> (+92°C)

T\_HYST2 Command Byte Value: 0010 0010<sub>b</sub> = 22<sub>h</sub>

**TABLE 4-11: REMOTE ZONE 2 TEMPERATURE SETPOINT, 8-BIT READ/WRITE**

D[7]	D[6]	D[5]	D[4]	D[3]	D[2]	D[1]	D[0]
MSB	Bit 6	Bit 5	Bit 4	Bit 3	Bit 2	Bit 1	LSB
Remote zone 2 temperature setpoint							
Bits	Function			Operation			
D[7:0]	Remote zone 2 temperature setpoint, <a href="#">Note 1</a>			Read/Write			

**Note 1:** Each LSB represents one degree Centigrade. The values are in a two's complement format such that 0°C is reported as 0000 0000<sub>b</sub>. See [Temperature Data Format](#) for more details.

T\_SET2 Power-Up Value: 0110 0001<sub>b</sub> = 61<sub>h</sub> (+97°C)

T\_SET2 Command Byte Value: 0010 0011<sub>b</sub> = 23<sub>h</sub>

## 5.0 APPLICATIONS

### 5.1 Remote Diode Selection

Most small-signal PNP transistors with characteristics similar to the JEDEC 2N3906 will perform well as remote temperature sensors. [Table 5-1](#) lists several examples of such parts that Microchip has tested for use with the MIC384. Other transistors equivalent to these should also work well.

**TABLE 5-1: SUITABLE TRANSISTORS**

Vendor	Part Number	Package
Fairchild	MMBT3906	SOT-23
On Semiconductor	MMBT3906L	SOT-23
Phillips Semiconductor	PMBT3906	SOT-23
Samsung	KST3906-TF	SOT-23

### 5.2 Minimizing Errors

#### 5.2.1 SELF-HEATING

One concern when using a part with the temperature accuracy and resolution of the MIC384 is to avoid errors induced by self-heating ( $V_{DD} \times I_{DD}$ ) + ( $V_{OL} \times I_{OL}$ ). In order to understand what level of error this might represent, and how to reduce that error, the dissipation in the MIC384 must be calculated and its effects reduced to a temperature offset.

The worst-case operating condition for the MIC384 is when  $V_{DD} = 5.5V$ , MSOP-08 package. The maximum power dissipated in the part is given in [Equation 5-1](#).

**EQUATION 5-1: WORST CASE SELF-HEATING**

$$P_D = (I_{DD} \times V_{DD}) + (I_{OL(DATA)} \times V_{OL(DATA)}) + (I_{OL(INT)} \times V_{OL(INT)})$$

$$P_D = (0.75mA \times 5.5V) + (6mA \times 0.8V) + (6mA \times 0.8V)$$

$$P_D = 13.73mW$$

$R_{\theta JA}$  of the MSOP-8 package is  $206^\circ C/W$ . The maximum  $\Delta T_J$  relative to  $T_A$  due to self-heating is  $13.73mW \times 206^\circ C/W = 2.83^\circ C$ .

In most applications, the /INT output will be low for at most a few milliseconds before the host resets it back to the high state, making its duty cycle low enough that

its contribution to self-heating of the MIC384 is negligible. Similarly, the DATA pin will in all likelihood have a duty cycle of substantially below 25% in the low state. These considerations, combined with more typical device and application parameters, give a better system-level view of device self-heating in interrupt-mode usage. This is illustrated by [Equation 5-2](#).

**EQUATION 5-2: REAL WORLD SELF-HEATING EXAMPLE**

$$[(0.35mA I_{DD(TYP)} \times 3.3V) + (25\% \times 1.5mA I_{OL(DATA)} \times 0.3V)] + (1\% \times 1.5mA I_{OL(INT)} \times 0.3V) = 1.27mW$$

$$\Delta T_J = (1.27mW \times 206^\circ C/W) = 0.262^\circ C$$

If the part is to be used in comparator mode, calculations similar to those shown in [Equation 5-2](#) (accounting for the expected value and duty cycle of  $I_{OL(INT)}$ ) will give a good estimate of the device's self-heating error.

In any application, the best test is to verify performance against calculation in the final application environment. This is especially true when dealing with systems for which some of the thermal data (e.g., PC board thermal conductivity and ambient temperature) may be poorly defined or unobtainable except by empirical means.

### 5.3 Series Resistance

The operation of the MIC384 depends upon sensing the  $\Delta V_{CB-E}$  of a diode-connected PNP transistor ("diode") at two different current levels. For remote temperature measurements, this is done using an external diode connected between T1, T2, and ground.

Because this technique relies upon measuring the relatively small voltage difference resulting from two levels of current through the external diode, any resistance in series with the external diode will cause an error in the temperature reading from the MIC384. A good rule of thumb is that for each ohm in series with the external transistor, there will be a  $0.9^\circ C$  error in the MIC384's temperature measurement. It isn't difficult to keep the series resistance well below an ohm (typically less than  $0.1\Omega$ ), so this will rarely be an issue.

### 5.4 Filter Capacitor Selection

It is sometimes desirable to use a filter capacitor between the T1 and/or T2 pins and the GND pin of the MIC384. The use of this capacitor is recommended in environments with a lot of high frequency noise (such as digital switching noise), or if long wires are used to

# MIC384

attach to the remote diode. The maximum recommended total capacitance from the T1 or T2 pin to GND is 2700 pF. This typically suggests the use of a 2200 pF NP0 or C0G ceramic capacitor with a 10% tolerance.

If the remote diode is to be at a distance of more than about 6" to 12" from the MIC384, using twisted pair wiring or shielded microphone cable for the connections to the diode can significantly help reduce noise pickup. If using a long run of shielded cable, remember to subtract the cable's conductor-to-shield capacitance from the 2700 pF maximum total capacitance.

## 5.5 Layout Considerations

The following guidelines should be kept in mind when designing and laying out circuits using the MIC384:

1. Place the MIC384 as close to the remote diode as possible, while taking care to avoid severe noise sources such as high frequency power transformers, CRTs, memory and data busses, and the like.
2. Because any conductance from the various voltages on the PC Board to the T1 or T2 line can induce serious errors, it is good practice to guard the remote diode's emitter trace with a pair of ground traces. These ground traces should be returned to the MIC384's own ground pin. They should not be grounded at any other part of their run. However, it is highly desirable to use these guard traces to carry the diode's own ground return back to the ground pin of the MIC384, thereby providing a Kelvin connection for the base of the diode. See [Figure 5-1](#).
3. When using the MIC384 to sense the temperature of a processor or other device which has an integral thermal diode, e.g., Intel's Pentium III, connect the emitter and base of the remote sensor to the MIC384 using the guard traces and Kelvin return shown in [Figure 5-1](#). The collector of the remote diode is typically inaccessible to the user on these devices. To allow for this, the MIC384 has superb rejection of noise appearing from collector to GND, as long as the base to ground connection is relatively quiet.
4. Due to the small currents involved in the measurement of the remote diode's  $\Delta V_{BE}$ , it is important to adequately clean the PC board after soldering to prevent current leakage. This is most likely to show up as an issue in situations where water-soluble soldering fluxes are used.
5. In general, wider traces for the ground and T1/T2 lines will help reduce susceptibility to radiated noise (wider traces are less inductive). Use trace widths and spacing of 10 mm wherever possible and provide a ground plane under the MIC384 and under the connections from the MIC384 to the remote diode. This will help guard against stray noise pickup.
6. Always place a good quality power supply bypass capacitor directly adjacent to, or underneath, the MIC384. This should be a 0.1  $\mu$ F ceramic capacitor. Surface-mount parts provide the best bypassing because of their low inductance.
7. When the MIC384 is being powered from particularly noisy power supplies, or from supplies that may have sudden high-amplitude spikes appearing on them, it can be helpful to add additional power supply filtering. This should be implemented as a 100 $\Omega$  resistor in series with the part's VDD pin, and a 4.7  $\mu$ F, 6.3V electrolytic capacitor from VDD to GND. See [Figure 5-2](#).

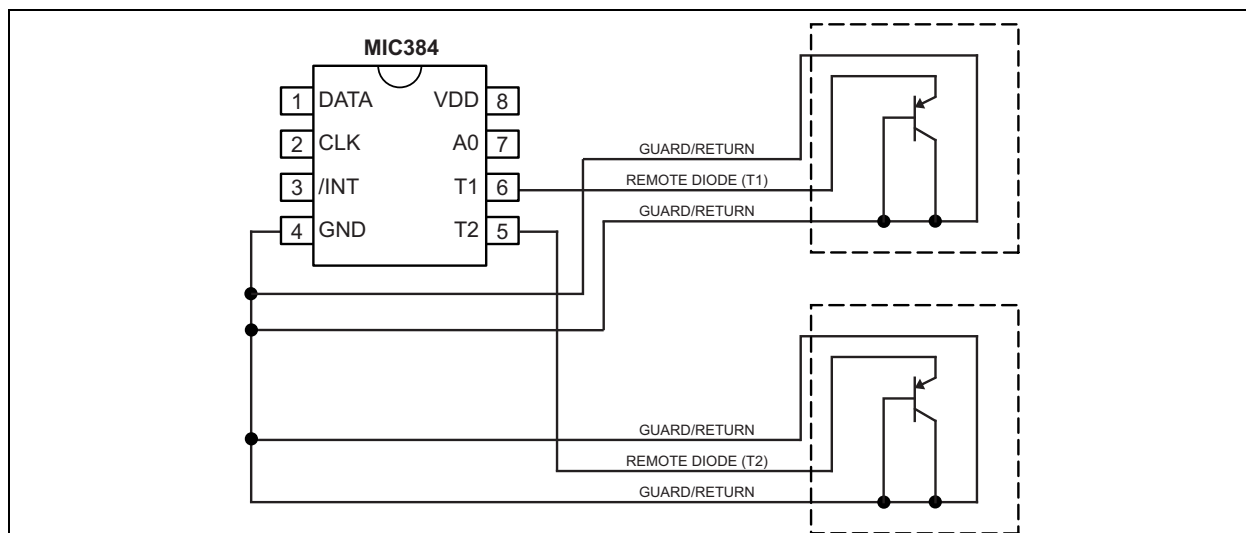

**FIGURE 5-1:** Guard Traces/Kelvin Ground Returns.

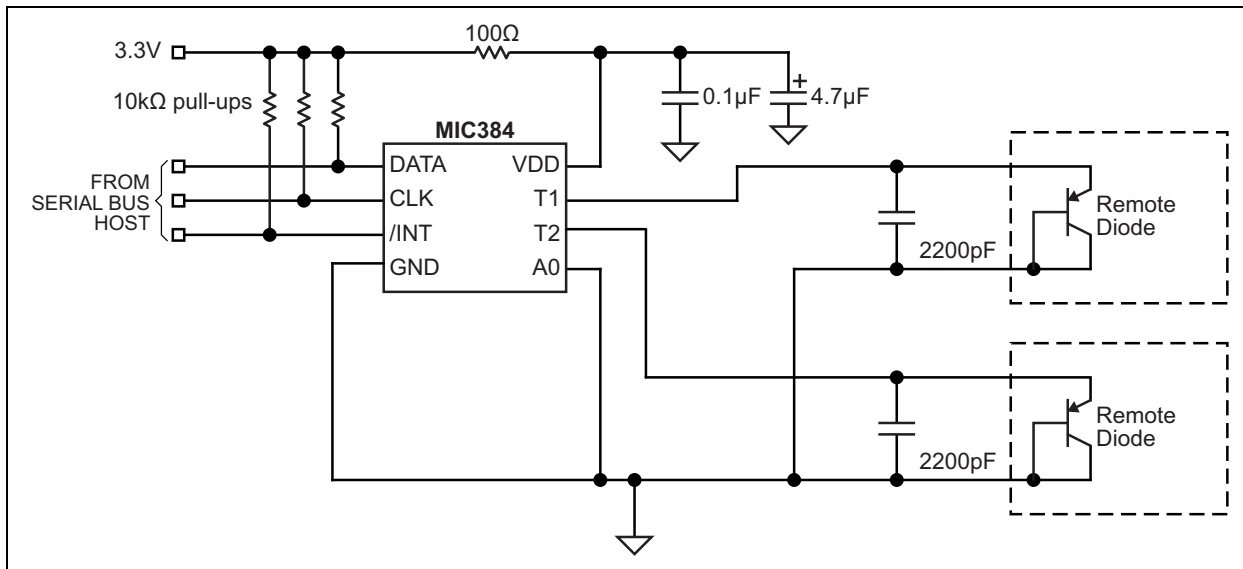
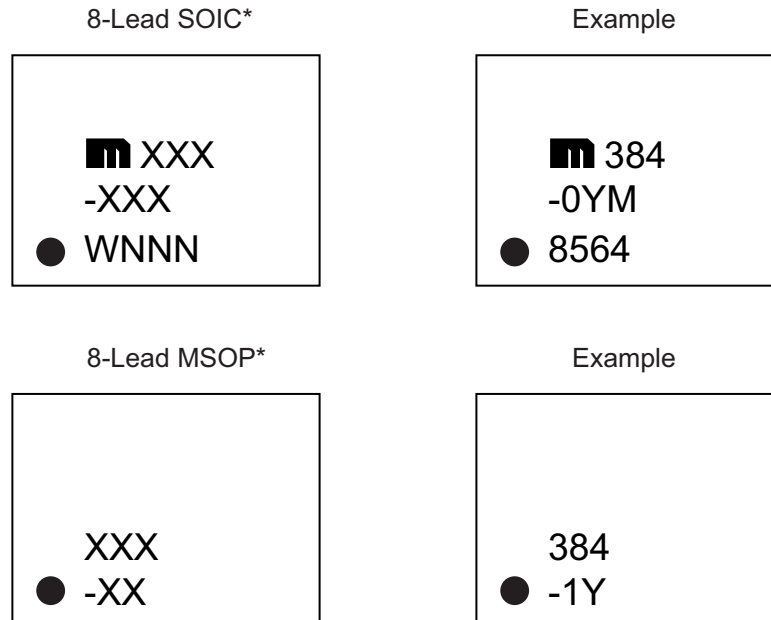

**FIGURE 5-2:** VDD Decoupling for very Noisy Supplies.

# MIC384

## 6.0 PACKAGING INFORMATION

### 6.1 Package Marking Information



Part Number	Base Address (Note 1)
MIC384-0YM and MIC384-0YMM	100 100x
MIC384-1YM and MIC384-1YMM	100 101x
MIC384-2YM and MIC384-2YMM	100 110x
MIC384-3YM and MIC384-3YMM	100 111x

**Note 1:** The least significant bit of the client address is determined by the state of the A0 pin.

<p><b>Legend:</b></p> <ul style="list-style-type: none"> <li>XX...X Product code or customer-specific information</li> <li>Y Year code (last digit of calendar year)</li> <li>YY Year code (last 2 digits of calendar year)</li> <li>WW Week code (week of January 1 is week '01')</li> <li>NNN Alphanumeric traceability code</li> <li>(e3) Pb-free JEDEC® designator for Matte Tin (Sn)</li> <li>* This package is Pb-free. The Pb-free JEDEC designator (e3) can be found on the outer packaging for this package.</li> <li>•, ▲, ▼ Pin one index is identified by a dot, delta up, or delta down (triangle mark).</li> </ul>	<p><b>Note:</b> In the event the full Microchip part number cannot be marked on one line, it will be carried over to the next line, thus limiting the number of available characters for customer-specific information. Package may or may not include the corporate logo.</p> <p>Underbar ( _ ) and/or Overbar ( ¯ ) symbol may not be to scale.</p>
--	---

## 8-Lead SOIC Package Outline and Recommended Land Pattern

**TITLE**

8 LEAD SOICN PACKAGE OUTLINE & RECOMMENDED LAND PATTERN

DRAWING #	SOICN-8LD-PL-1	UNIT	INCH [MM]
-----------	----------------	------	-----------

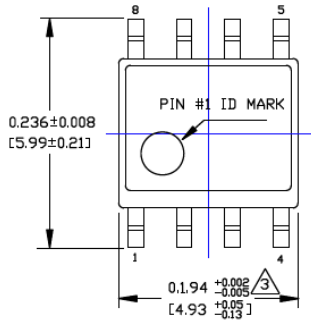

TOP VIEW

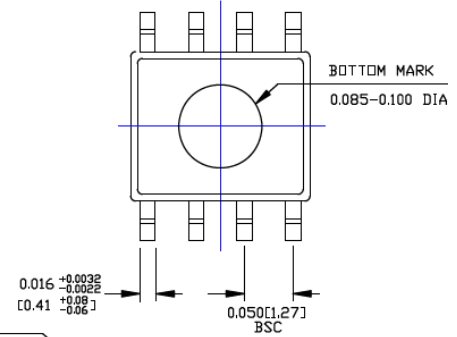

BOTTOM VIEW

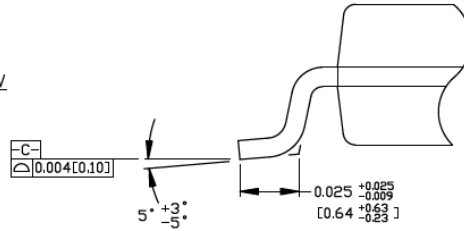

DETAIL "A"

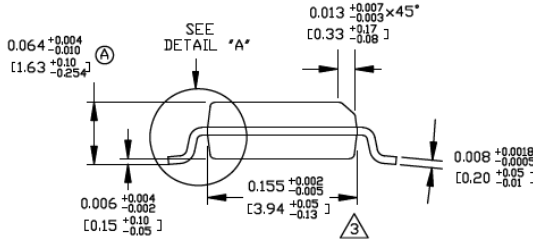

END VIEW

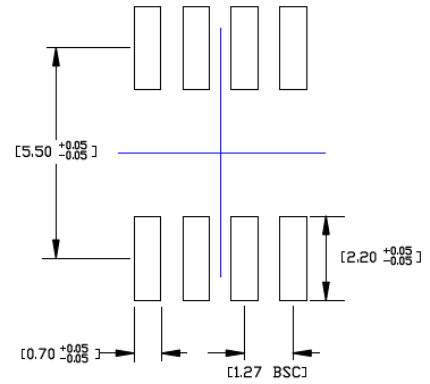

RECOMMENDED LAND PATTERN

- NOTES:
1. DIMENSIONS ARE IN INCHES[MM].
  2. CONTROLLING DIMENSION: INCHES.
  3. DIMENSION DOES NOT INCLUDE MOLD FLASH OR PROTRUSIONS, EITHER OF WHICH SHALL NOT EXCEED 0.010[0.25] PER SIDE.

Note: For the most current package drawings, please see the Microchip Packaging Specification located at <http://www.microchip.com/packaging>.

# MIC384

## 8-Lead MSOP Package Outline and Recommended Land Pattern

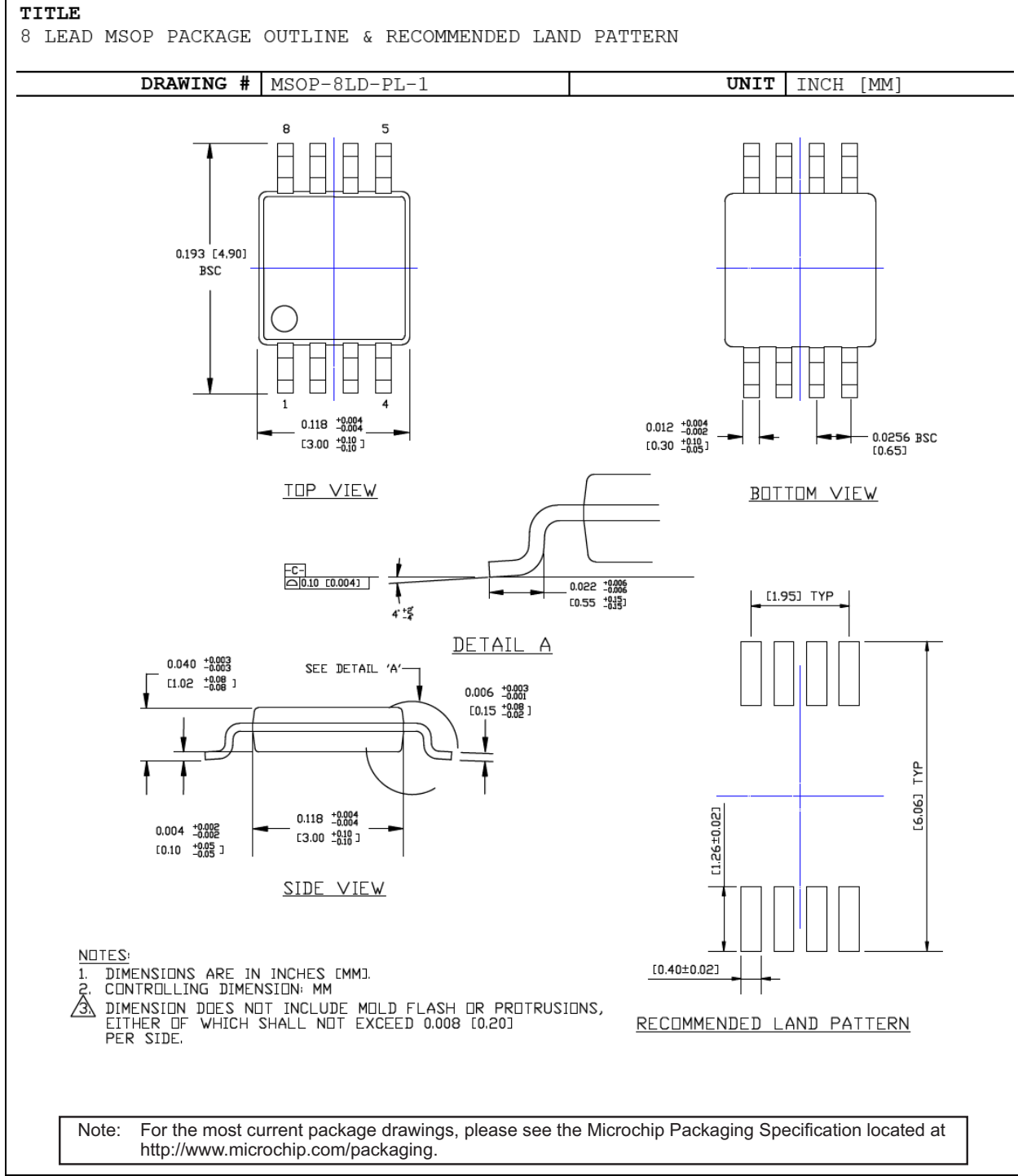

**APPENDIX A: REVISION HISTORY****Revision A (December 2020)**

- Converted Micrel data sheet MIC384 to Microchip data sheet DS20006469A.
- Minor grammatical corrections throughout.

# MIC384

---

NOTES:

**PRODUCT IDENTIFICATION SYSTEM**

To order or obtain information, e.g., on pricing or delivery, contact your local Microchip representative or sales office.

<u>PART NO.</u>	<u>-X</u>	<u>X</u>	<u>XX</u>	<u>-XX</u>
Device	Client Address	Junction Temp. Range	Package	Media Type
<b>Device:</b>	MIC384:	Three-Zone Thermal Supervisor		
<b>Client Address:</b>	0 =	100 100x		
	1 =	100 101x		
	2 =	100 110x		
	3 =	100 111x		
<b>Junction Temperature Range:</b>	Y =	-55°C to +125°C		
<b>Package:</b>	M =	8-Lead SOIC		
	MM =	8-Lead MSOP		
<b>Media Type</b>	<blank>=	95/Tube (SOIC Package only)		
	<blank>=	100/Tube (MSOP Package only)		
	TR =	2,500/Reel		

**Examples:**

- a) MIC384-0YM-TR: 3-Zone Thermal Supervisor, 100 100x Client Address, -55°C to +125°C Junction Temperature Range, 8-Lead SOIC, 2,500/Reel
- b) MIC384-2YMM: 3-Zone Thermal Supervisor, 100 110x Client Address, -55°C to +125°C Junction Temperature Range, 8-Lead MSOP, 100/Tube
- c) MIC384-1YM: 3-Zone Thermal Supervisor, 100 101x Client Address, -55°C to +125°C Junction Temperature Range, 8-Lead SOIC, 95/Tube
- d) MIC384-3YMM-TR: 3-Zone Thermal Supervisor, 100 111x Client Address, -55°C to +125°C Junction Temperature Range, 8-Lead MSOP, 2,500/Reel

**Note 1:** Tape and Reel identifier only appears in the catalog part number description. This identifier is used for ordering purposes and is not printed on the device package. Check with your Microchip Sales Office for package availability with the Tape and Reel option.

# MIC384

---

NOTES:

**Note the following details of the code protection feature on Microchip devices:**

- Microchip products meet the specifications contained in their particular Microchip Data Sheet.
- Microchip believes that its family of products is secure when used in the intended manner and under normal conditions.
- There are dishonest and possibly illegal methods being used in attempts to breach the code protection features of the Microchip devices. We believe that these methods require using the Microchip products in a manner outside the operating specifications contained in Microchip's Data Sheets. Attempts to breach these code protection features, most likely, cannot be accomplished without violating Microchip's intellectual property rights.
- Microchip is willing to work with any customer who is concerned about the integrity of its code.
- Neither Microchip nor any other semiconductor manufacturer can guarantee the security of its code. Code protection does not mean that we are guaranteeing the product is "unbreakable." Code protection is constantly evolving. We at Microchip are committed to continuously improving the code protection features of our products. Attempts to break Microchip's code protection feature may be a violation of the Digital Millennium Copyright Act. If such acts allow unauthorized access to your software or other copyrighted work, you may have a right to sue for relief under that Act.

Information contained in this publication is provided for the sole purpose of designing with and using Microchip products. Information regarding device applications and the like is provided only for your convenience and may be superseded by updates. It is your responsibility to ensure that your application meets with your specifications.

THIS INFORMATION IS PROVIDED BY MICROCHIP "AS IS". MICROCHIP MAKES NO REPRESENTATIONS OR WARRANTIES OF ANY KIND WHETHER EXPRESS OR IMPLIED, WRITTEN OR ORAL, STATUTORY OR OTHERWISE, RELATED TO THE INFORMATION INCLUDING BUT NOT LIMITED TO ANY IMPLIED WARRANTIES OF NON-INFRINGEMENT, MERCHANTABILITY, AND FITNESS FOR A PARTICULAR PURPOSE OR WARRANTIES RELATED TO ITS CONDITION, QUALITY, OR PERFORMANCE.

IN NO EVENT WILL MICROCHIP BE LIABLE FOR ANY INDIRECT, SPECIAL, PUNITIVE, INCIDENTAL OR CONSEQUENTIAL LOSS, DAMAGE, COST OR EXPENSE OF ANY KIND WHATSOEVER RELATED TO THE INFORMATION OR ITS USE, HOWEVER CAUSED, EVEN IF MICROCHIP HAS BEEN ADVISED OF THE POSSIBILITY OR THE DAMAGES ARE FORESEEABLE. TO THE FULLEST EXTENT ALLOWED BY LAW, MICROCHIP'S TOTAL LIABILITY ON ALL CLAIMS IN ANY WAY RELATED TO THE INFORMATION OR ITS USE WILL NOT EXCEED THE AMOUNT OF FEES, IF ANY, THAT YOU HAVE PAID DIRECTLY TO MICROCHIP FOR THE INFORMATION. Use of Microchip devices in life support and/or safety applications is entirely at the buyer's risk, and the buyer agrees to defend, indemnify and hold harmless Microchip from any and all damages, claims, suits, or expenses resulting from such use. No licenses are conveyed, implicitly or otherwise, under any Microchip intellectual property rights unless otherwise stated.

**Trademarks**

The Microchip name and logo, the Microchip logo, Adaptec, AnyRate, AVR, AVR logo, AVR Freaks, BesTime, BitCloud, chipKIT, chipKIT logo, CryptoMemory, CryptoRF, dsPIC, FlashFlex, flexPWR, HELDO, IGL00, JukeBlox, KeeLoq, Kleer, LANCheck, LinkMD, maXStylus, maXTouch, MediaLB, megaAVR, Microsemi, Microsemi logo, MOST, MOST logo, MPLAB, OptoLyzer, PackeTime, PIC, picoPower, PICSTART, PIC32 logo, PolarFire, Prochip Designer, QTouch, SAM-BA, SenGenuity, SpyNIC, SST, SST Logo, SuperFlash, Symmetricom, SyncServer, Tachyon, TimeSource, tinyAVR, UNI/O, Vectron, and XMEGA are registered trademarks of Microchip Technology Incorporated in the U.S.A. and other countries.

AgileSwitch, APT, ClockWorks, The Embedded Control Solutions Company, EtherSynch, FlashTec, Hyper Speed Control, HyperLight Load, IntelliMOS, Libero, motorBench, mTouch, Powermite 3, Precision Edge, ProASIC, ProASIC Plus, ProASIC Plus logo, Quiet-Wire, SmartFusion, SyncWorld, Temux, TimeCesium, TimeHub, TimePictra, TimeProvider, WinPath, and ZL are registered trademarks of Microchip Technology Incorporated in the U.S.A.

Adjacent Key Suppression, AKS, Analog-for-the-Digital Age, Any Capacitor, AnyIn, AnyOut, Augmented Switching, BlueSky, BodyCom, CodeGuard, CryptoAuthentication, CryptoAutomotive, CryptoCompanion, CryptoController, dsPICDEM, dsPICDEM.net, Dynamic Average Matching, DAM, ECAN, Espresso T1S, EtherGREEN, IdealBridge, In-Circuit Serial Programming, ICSP, INICnet, Intelligent Paralleling, Inter-Chip Connectivity, JitterBlocker, maxCrypto, maxView, memBrain, Mindi, MiWi, MPASM, MPF, MPLAB Certified logo, MPLIB, MPLINK, MultiTRAK, NetDetach, Omniscient Code Generation, PICDEM, PICDEM.net, PICkit, PICtail, PowerSmart, PureSilicon, QMatrix, REAL ICE, Ripple Blocker, RTAX, RTG4, SAM-ICE, Serial Quad I/O, simpleMAP, SimpliPHY, SmartBuffer, SMART-I.S., storClad, SQI, SuperSwitcher, SuperSwitcher II, Switchtec, SynchroPHY, Total Endurance, TSHARC, USBCheck, VariSense, VectorBlox, VeriPHY, ViewSpan, WiperLock, XpressConnect, and ZENA are trademarks of Microchip Technology Incorporated in the U.S.A. and other countries.

SQTP is a service mark of Microchip Technology Incorporated in the U.S.A.

The Adaptec logo, Frequency on Demand, Silicon Storage Technology, and Symmcom are registered trademarks of Microchip Technology Inc. in other countries.

GestIC is a registered trademark of Microchip Technology Germany II GmbH & Co. KG, a subsidiary of Microchip Technology Inc., in other countries.

All other trademarks mentioned herein are property of their respective companies.

© 2020, Microchip Technology Incorporated, All Rights Reserved.

ISBN: 978-1-5224-7366-4

For information regarding Microchip's Quality Management Systems, please visit [www.microchip.com/quality](http://www.microchip.com/quality).



# MICROCHIP

## Worldwide Sales and Service

### AMERICAS

**Corporate Office**  
2355 West Chandler Blvd.  
Chandler, AZ 85224-6199  
Tel: 480-792-7200  
Fax: 480-792-7277  
Technical Support:  
<http://www.microchip.com/support>  
Web Address:  
[www.microchip.com](http://www.microchip.com)

#### Atlanta

Duluth, GA  
Tel: 678-957-9614  
Fax: 678-957-1455

#### Austin, TX

Tel: 512-257-3370

#### Boston

Westborough, MA  
Tel: 774-760-0087  
Fax: 774-760-0088

#### Chicago

Itasca, IL  
Tel: 630-285-0071  
Fax: 630-285-0075

#### Dallas

Addison, TX  
Tel: 972-818-7423  
Fax: 972-818-2924

#### Detroit

Novi, MI  
Tel: 248-848-4000

#### Houston, TX

Tel: 281-894-5983

#### Indianapolis

Noblesville, IN  
Tel: 317-773-8323  
Fax: 317-773-5453  
Tel: 317-536-2380

#### Los Angeles

Mission Viejo, CA  
Tel: 949-462-9523  
Fax: 949-462-9608  
Tel: 951-273-7800

#### Raleigh, NC

Tel: 919-844-7510

#### New York, NY

Tel: 631-435-6000

#### San Jose, CA

Tel: 408-735-9110  
Tel: 408-436-4270

#### Canada - Toronto

Tel: 905-695-1980  
Fax: 905-695-2078

### ASIA/PACIFIC

**Australia - Sydney**  
Tel: 61-2-9868-6733

**China - Beijing**  
Tel: 86-10-8569-7000

**China - Chengdu**  
Tel: 86-28-8665-5511

**China - Chongqing**  
Tel: 86-23-8980-9588

**China - Dongguan**  
Tel: 86-769-8702-9880

**China - Guangzhou**  
Tel: 86-20-8755-8029

**China - Hangzhou**  
Tel: 86-571-8792-8115

**China - Hong Kong SAR**  
Tel: 852-2943-5100

**China - Nanjing**  
Tel: 86-25-8473-2460

**China - Qingdao**  
Tel: 86-532-8502-7355

**China - Shanghai**  
Tel: 86-21-3326-8000

**China - Shenyang**  
Tel: 86-24-2334-2829

**China - Shenzhen**  
Tel: 86-755-8864-2200

**China - Suzhou**  
Tel: 86-186-6233-1526

**China - Wuhan**  
Tel: 86-27-5980-5300

**China - Xian**  
Tel: 86-29-8833-7252

**China - Xiamen**  
Tel: 86-592-2388138

**China - Zhuhai**  
Tel: 86-756-3210040

### ASIA/PACIFIC

**India - Bangalore**  
Tel: 91-80-3090-4444

**India - New Delhi**  
Tel: 91-11-4160-8631

**India - Pune**  
Tel: 91-20-4121-0141

**Japan - Osaka**  
Tel: 81-6-6152-7160

**Japan - Tokyo**  
Tel: 81-3-6880-3770

**Korea - Daegu**  
Tel: 82-53-744-4301

**Korea - Seoul**  
Tel: 82-2-554-7200

**Malaysia - Kuala Lumpur**  
Tel: 60-3-7651-7906

**Malaysia - Penang**  
Tel: 60-4-227-8870

**Philippines - Manila**  
Tel: 63-2-634-9065

**Singapore**  
Tel: 65-6334-8870

**Taiwan - Hsin Chu**  
Tel: 886-3-577-8366

**Taiwan - Kaohsiung**  
Tel: 886-7-213-7830

**Taiwan - Taipei**  
Tel: 886-2-2508-8600

**Thailand - Bangkok**  
Tel: 66-2-694-1351

**Vietnam - Ho Chi Minh**  
Tel: 84-28-5448-2100

### EUROPE

**Austria - Wels**  
Tel: 43-7242-2244-39  
Fax: 43-7242-2244-393

**Denmark - Copenhagen**  
Tel: 45-4485-5910  
Fax: 45-4485-2829

**Finland - Espoo**  
Tel: 358-9-4520-820

**France - Paris**  
Tel: 33-1-69-53-63-20  
Fax: 33-1-69-30-90-79

**Germany - Garching**  
Tel: 49-8931-9700

**Germany - Haan**  
Tel: 49-2129-3766400

**Germany - Heilbronn**  
Tel: 49-7131-72400

**Germany - Karlsruhe**  
Tel: 49-721-625370

**Germany - Munich**  
Tel: 49-89-627-144-0  
Fax: 49-89-627-144-44

**Germany - Rosenheim**  
Tel: 49-8031-354-560

**Israel - Ra'anana**  
Tel: 972-9-744-7705

**Italy - Milan**  
Tel: 39-0331-742611  
Fax: 39-0331-466781

**Italy - Padova**  
Tel: 39-049-7625286

**Netherlands - Drunen**  
Tel: 31-416-690399  
Fax: 31-416-690340

**Norway - Trondheim**  
Tel: 47-7288-4388

**Poland - Warsaw**  
Tel: 48-22-3325737

**Romania - Bucharest**  
Tel: 40-21-407-87-50

**Spain - Madrid**  
Tel: 34-91-708-08-90  
Fax: 34-91-708-08-91

**Sweden - Gothenberg**  
Tel: 46-31-704-60-40

**Sweden - Stockholm**  
Tel: 46-8-5090-4654

**UK - Wokingham**  
Tel: 44-118-921-5800  
Fax: 44-118-921-5820

## OUR CERTIFICATE

DiGi provide top-quality products and perfect service for customer worldwide through standardization, technological innovation and continuous improvement. DiGi through third-party certification, we stricly control the quality of products and services. Welcome your RFQ to

Email: [Info@DiGi-Electronics.com](mailto:Info@DiGi-Electronics.com)



Tel: +00 852-30501935

RFQ Email: [Info@DiGi-Electronics.com](mailto:Info@DiGi-Electronics.com)

DiGi is a global authorized distributor of electronic components.