

PL133-47SC-R Datasheet

www.digi-electronics.com

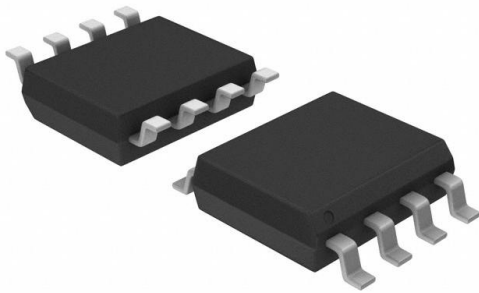

<https://www.DiGi-Electronics.com>

DiGi Electronics Part Number	PL133-47SC-R-DG
Manufacturer	Microchip Technology
Manufacturer Product Number	PL133-47SC-R
Description	IC CLK BUFFER 1:4 150MHZ 8SOP
Detailed Description	Clock Fanout Buffer (Distribution) IC 1:4 150 MHz 8-SOIC (0.154", 3.90mm Width)

This model PL133-47SC-R is available at DiGi Electronics.

DiGi Electronics offers a global database of semiconductor and electronic component datasheets.

We welcome your inquiries regarding pricing, lead time, or other product-related questions.

 [Request a Quote](#)

 [Datasheet Search](#)



Tel: +00 852-30501935

RFQ Email: Info@DiGi-Electronics.com

DiGi is a global authorized distributor of electronic components.

Purchase and inquiry

Manufacturer Product Number:

PL133-475C-R

Series:

-

Type:

Fanout Buffer (Distribution)

Ratio - Input:Output:

1:4

Input:

LVC MOS

Frequency - Max:

150 MHz

Operating Temperature:

0°C ~ 70°C

Package / Case:

8-SOIC (0.154", 3.90mm Width)

Base Product Number:

PL133

Manufacturer:

Microchip Technology

Product Status:

Active

Number of Circuits:

1

Differential - Input:Output:

No/No

Output:

LVC MOS

Voltage - Supply:

2.25V ~ 3.63V

Mounting Type:

Surface Mount

Supplier Device Package:

8-SOP

Environmental & Export classification

RoHS Status:

ROHS3 Compliant

REACH Status:

REACH Unaffected

HTSUS:

8542.39.0001

Moisture Sensitivity Level (MSL):

3 (168 Hours)

ECCN:

EAR99



PL133-47

Low-Power DC to 150 MHz 1:4 Fanout Buffer IC

Features

- 1:4 LVCMOS Output Fanout Buffer from DC to 150 MHz
- Low Additive Phase Jitter of 60 fs RMS
- 8 mA Output Drive Strength
- Low Power Consumption for Portable Applications
- Automotive Applications Grade Compliant
- Low Input-Output Delay
- Output-Output Skew <250 ps
- 2.5V to 3.3V, $\pm 10\%$ Operation
- 1.8V $+10\%/-5\%$ Operation up to 67 MHz
- Operating Temperature Range:
 - Commercial: 0°C to $+70^{\circ}\text{C}$
 - Industrial: -40°C to $+85^{\circ}\text{C}$
- Available in 8-Pin SOIC Package

General Description

The PL133-47 is an advanced fanout buffer design for high performance, low-power, small form factor applications. The PL133-47 accepts a reference clock input from DC to 150 MHz and provides four outputs of the same frequency.

The PL133-47 is offered in a SOIC-8L package and it offers the best phase noise, additive jitter performance, and lowest power consumption of any comparable IC.

Functional Block Diagram

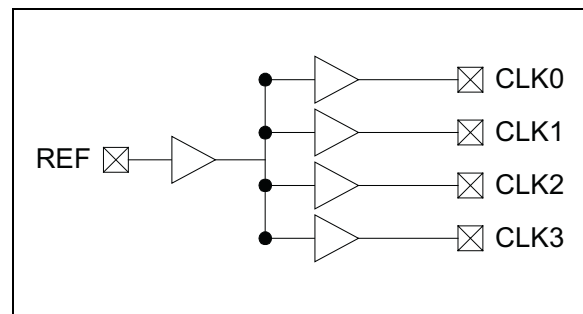

PL133-47

1.0 ELECTRICAL CHARACTERISTICS

Absolute Maximum Ratings †

Supply Voltage to Ground Potential	-0.5V to +4.6V
DC Input Voltage	$V_{SS} - 0.5V$ to +4.6V
Static Discharge Voltage (Per MIL-STD-883, Method 3015).....	>2000V

Operating Ratings †

Supply Voltage, V_{DD}	1.71V to 3.63V
--------------------------------	----------------

† **Notice:** Stresses above those listed under “Absolute Maximum Ratings” may cause permanent damage to the device. This is a stress rating only and functional operation of the device at those or any other conditions above those indicated in the operational sections of this specification is not intended. Exposure to maximum rating conditions for extended periods may affect device reliability.

ELECTRICAL CHARACTERISTICS

Electrical Characteristics:

Parameter	Symbol	Min.	Typ.	Max.	Units	Conditions
Input Low Voltage	V_{IL}	—	—	$0.3xV_{DD}$	V	Note 1
Input High Voltage	V_{IH}	$0.7xV_{DD}$	—	—	V	Note 1
Input Low Current	I_{IL}	—	—	50	μA	$V_{IN} = 0V$
Input High Current	I_{IH}	—	—	100	μA	$V_{IN} = V_{DD}$
Supply Current	I_{DD}	—	—	32	mA	66.67 MHz with unloaded outputs
Output Low Voltage	V_{OL}	—	—	0.5	V	$I_O = 8\text{ mA}$, $V_{DD} = 3.3V$
		—	—	0.5		$I_O = 6\text{ mA}$, $V_{DD} = 2.5V$
		—	—	0.5		$I_O = 4\text{ mA}$, $V_{DD} = 1.8V$
Output High Voltage	V_{OH}	$V_{DD} - 0.5$	—	—	V	$I_O = -8\text{ mA}$, $V_{DD} = 3.3V$
		$V_{DD} - 0.5$	—	—		$I_O = -6\text{ mA}$, $V_{DD} = 2.5V$
		$V_{DD} - 0.5$	—	—		$I_O = -4\text{ mA}$, $V_{DD} = 1.8V$
Load Capacitance	C_L	—	—	30	pF	Load Capacitance, below 100 MHz, $V_{DD} > 2.25V$
		—	—	10		Load Capacitance between 100 MHz and 134 MHz, $V_{DD} > 2.25V$
		—	—	5		Load Capacitance, above 134 MHz, $V_{DD} > 2.25V$
		—	—	15		Load Capacitance, below 67 MHz, $1.71V < V_{DD} < 2.25V$
Input Capacitance	C_{IN}	—	—	7	pF	—
Power-Up Time	t_{PU}	0.05	—	50	ms	Power-up time for all V_{DD} to reach minimum specified voltage (power ramps must be monotonic)

Note 1: REF input has a threshold voltage of $V_{DD}/2$.

SWITCHING CHARACTERISTICS [Note 2](#)**Electrical Characteristics:**

Parameter	Symbol	Min.	Typ.	Max.	Units	Conditions
Operating Frequency	f	DC	—	150	MHz	$V_{DD} = 3.3V, 2.5V$
		DC	—	67	MHz	$V_{DD} = 1.8V$
Duty Cycle = $t_2 \div t_1$	—	40	50	60	%	Measured at $V_{DD}/2$, Input is 50%
Rise Time	t_3	—	—	1.5	ns	Measured between 0.8V and 2.0V
Fall Time	t_4	—	—	1.5	ns	Measured between 0.8V and 2.0V
Output to Output Skew Note 1	t_5	—	—	250	ps	All outputs equally loaded
Propagation Delay, REF Rising Edge to CLKX Rising Edge Note 1	t_6	1	5	9.2	ns	Measured at $V_{DD}/2$

Note 1: Parameter is guaranteed by design and characterization.

2: All parameters are specified with loaded outputs.

NOISE CHARACTERISTICS**Electrical Characteristics:**

Parameter	Symbol	Min.	Typ.	Max.	Units	Conditions
Additive Phase Jitter	—	—	60	—	fs	$V_{DD} = 3.3V$, Frequency = 100 MHz Integration range 12 kHz - 20 MHz

PL133-47

TEMPERATURE SPECIFICATIONS (Note 1)

Parameters	Symbol	Min.	Typ.	Max.	Units	Conditions
Temperature Ranges+85						
Ambient Operating Temperature (T_A)	T_A	0	—	+70	°C	Commercial
		-40	—	+85		Industrial
Junction Temperature	T_J	—	—	+150	°C	—
Storage Temperature Range	T_S	-65	—	+150	°C	—
Package Thermal Resistance						
8-Lead SOIC	$R_{\theta JA}$	—	103.2	—	°C/W	—

Note 1: The maximum allowable power dissipation is a function of ambient temperature, the maximum allowable junction temperature and the thermal resistance from junction to air (i.e., T_A , T_J , θ_{JA}). Exceeding the maximum allowable power dissipation will cause the device operating junction temperature to exceed the maximum +150°C rating. Sustained junction temperatures above +150°C can impact the device reliability.

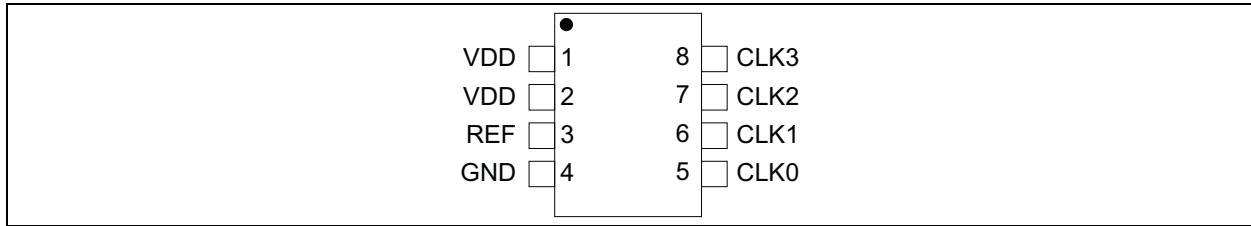
2.0 PIN DESCRIPTIONS**FIGURE 2-1:** Pin Configuration, 8-Lead SOIC Package.

The descriptions of the pins are listed in [Table 2-1](#).

TABLE 2-1: PIN FUNCTION TABLE

Pin Number	Pin Name	Type	Description
1, 2	VDD	P	Input reference frequency
3	REF	I	Buffered clock output
4	GND	P	Buffered clock output
5	CLK0	O	Buffered clock output
6	CLK1	O	Buffered clock output
7	CLK2	O	VDD connection
8	CLK3	O	GND connection

PL133-47

3.0 NOMINAL PERFORMANCE CHARACTERISTICS

Note: The graphs and tables provided following this note are a statistical summary based on a limited number of samples and are provided for informational purposes only. The performance characteristics listed herein are not tested or guaranteed. In some graphs or tables, the data presented may be outside the specified operating range (e.g., outside specified power supply range) and therefore outside the warranted range.

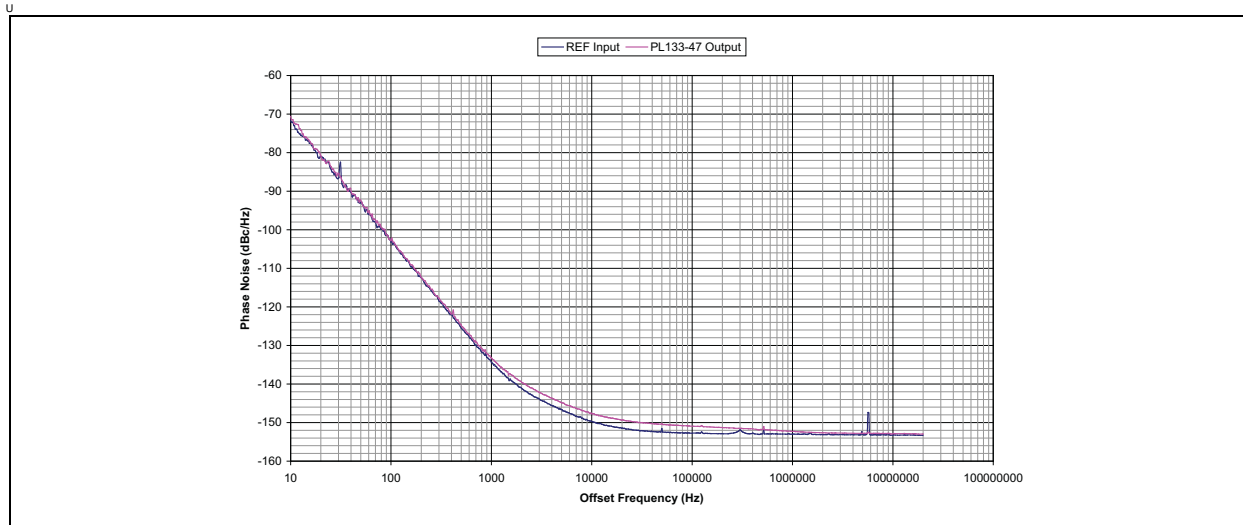

FIGURE 3-1: PL133-47 Additive Phase Jitter: $V_{DD} = 3.3V$, CLK-100 MHz, Integration Range 2 kHz - 20 MHz, 0.059 ps Typical.

When a buffer is used to pass a signal then the buffer will add a little bit of its own noise. The phase noise on the output of the buffer will be a little bit more than the phase noise in the input signal. The noise added by the buffer to the input signal is quantified by the additive phase jitter defined by the following formula:

EQUATION 3-1:

$$\text{AdditivePhaseJitter} = \sqrt{(\text{OutputPhaseJitter})^2 - (\text{InputPhaseJitter})^2}$$

4.0 SWITCHING WAVEFORMS

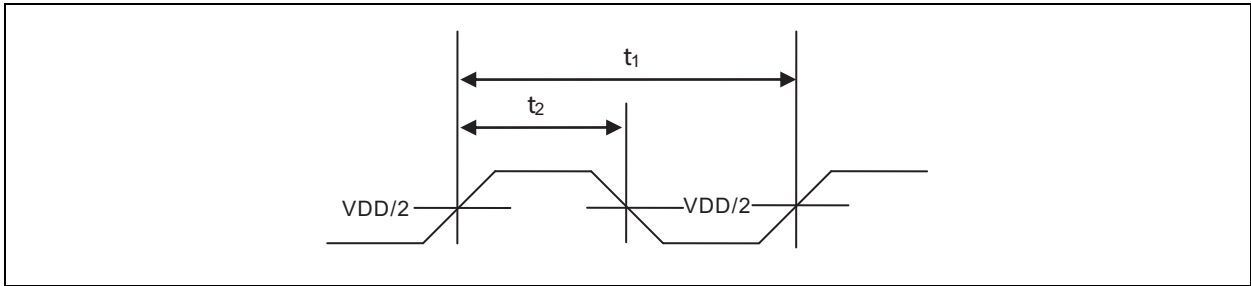

FIGURE 4-1: Duty Cycle Timing.

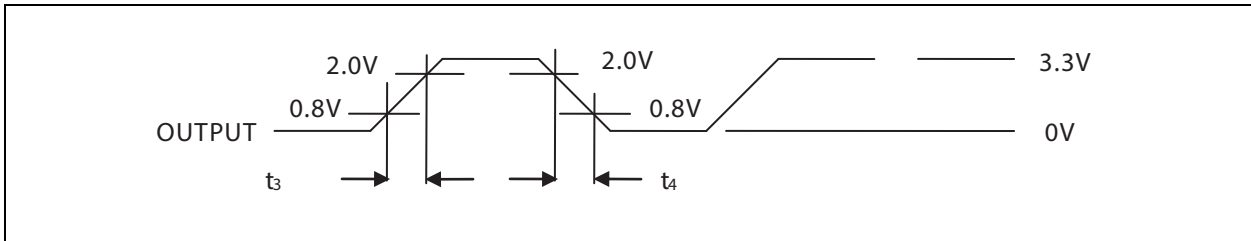

FIGURE 4-2: All Outputs Rise/Fall Time.

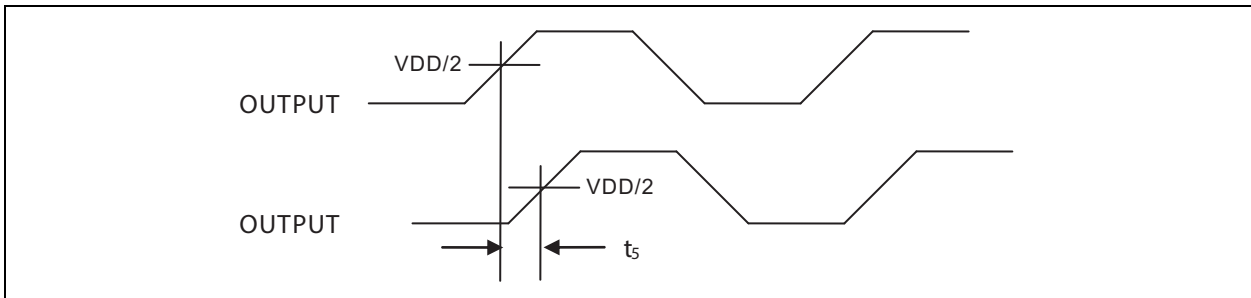

FIGURE 4-3: Output to Output Skew.

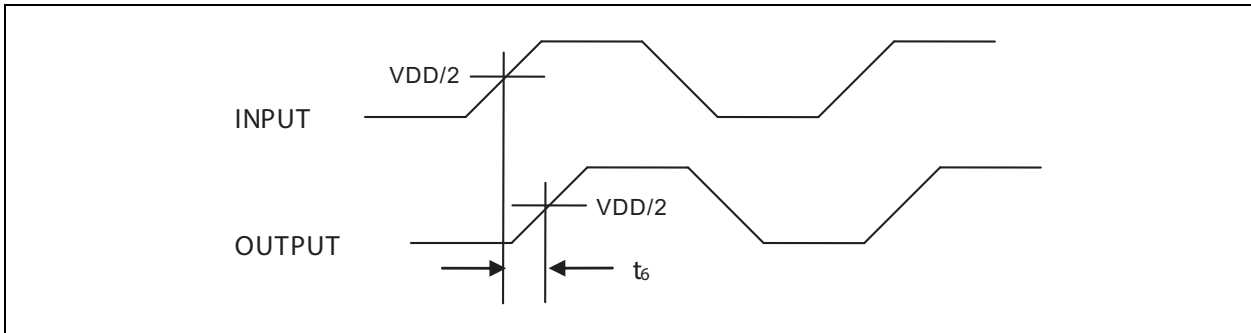

FIGURE 4-4: Input-Output Propagation Delay.

PL133-47

5.0 TEST CIRCUIT

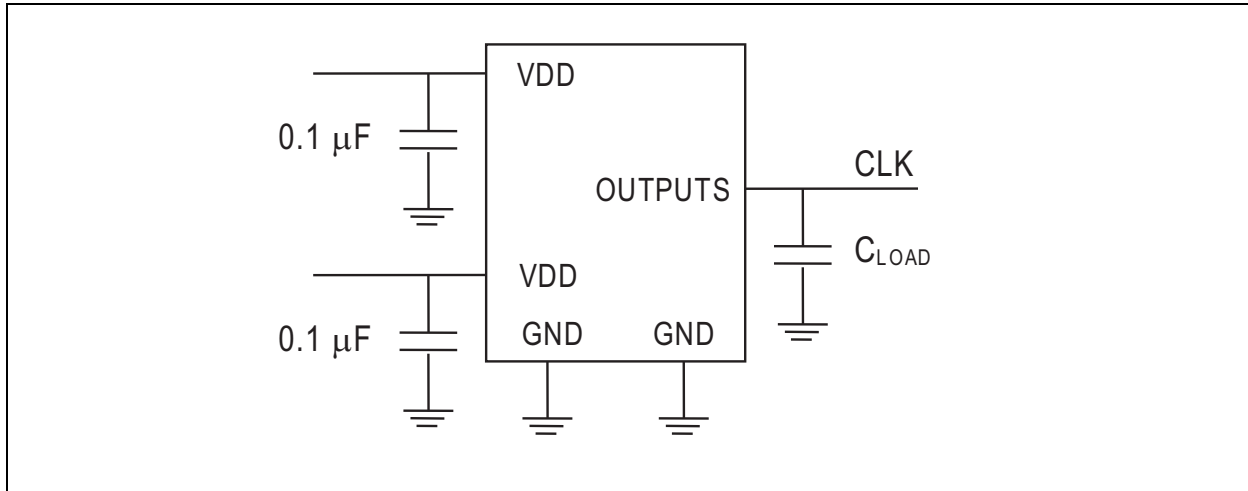

FIGURE 5-1: Test Circuit.

6.0 LAYOUT RECOMMENDATIONS

The following guidelines are to assist you with a performance optimized PCB design:

6.1 Signal Integrity and Termination Considerations

- Keep traces short
- Trace = Inductor. With a capacitive load this equals ringing
- Long trace = Transmission Line. Without proper termination this will cause reflections ringing and waveforms degradations.
- Use stripline or microstrip with defined impedance for long traces (> 1 inch)
- Match traces on one side of the board to avoid reflections bouncing back and forth.

6.2 Decoupling and Power Supply Considerations

- Place decoupling capacitors as close as possible to the VDD pin(s) to limit noise from the power supply
- Addition of a ferrite bead in series with VDD can help prevent noise from other board sources
- Value of decoupling capacitor is frequency dependant. Typical values to use are 0.1 μF for designs using frequencies <50 MHz and 0.01 μF for designs using frequencies >50 MHz

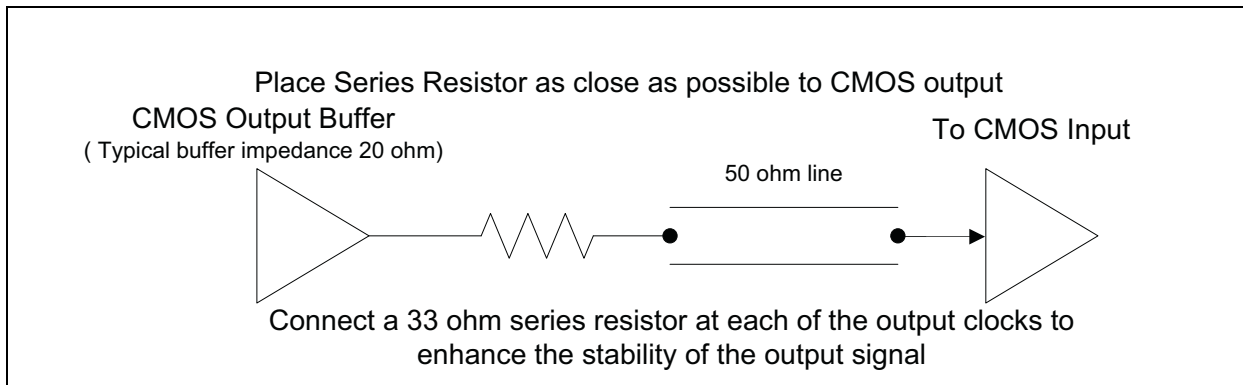

FIGURE 6-1: Typical CMOS Termination.

PL133-47

7.0 PACKAGING INFORMATION

7.1 Package Marking Information

8-Lead SOIC*



Example

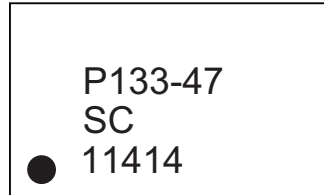

Legend:	XX...X	Product code, customer-specific information, or frequency in MHz without printed decimal point
	Y	Year code (last digit of calendar year)
	YY	Year code (last 2 digits of calendar year)
	WW	Week code (week of January 1 is week '01')
	NNN	Alphanumeric traceability code
	(e3)	Pb-free JEDEC® designator for Matte Tin (Sn)
	*	This package is Pb-free. The Pb-free JEDEC designator (e3) can be found on the outer packaging for this package.
	•, ▲, ▼	Pin one index is identified by a dot, delta up, or delta down (triangle mark).
Note:	In the event the full Microchip part number cannot be marked on one line, it will be carried over to the next line, thus limiting the number of available characters for customer-specific information. Package may or may not include the corporate logo.	
	Underbar (¯) and/or Overbar (¯) symbol may not be to scale.	

8-Lead SOIC Package Outline and Recommended Land Pattern



**8-Lead Plastic Small Outline (MSB) - Narrow, 3.90 mm (.150 In.) Body [SOIC]
Atmel Legacy Global Package Code SWB**

Note: For the most current package drawings, please see the Microchip Packaging Specification located at <http://www.microchip.com/packaging>

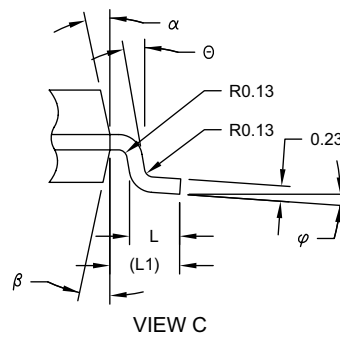
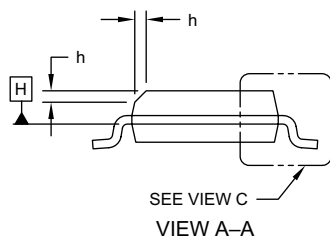
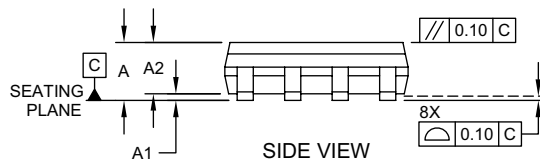
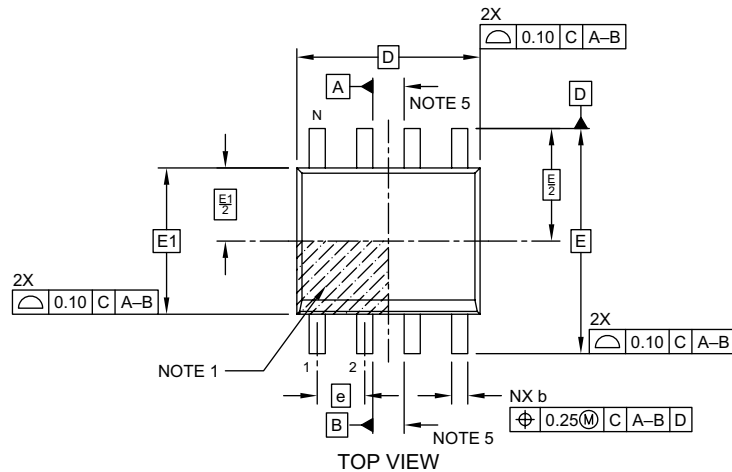

Microchip Technology Drawing No. C04-057-MSB Rev F Sheet 1 of 2

© 2020 Microchip Technology Incorporated

PL133-47

8-Lead SOIC Package Outline and Recommended Land Pattern



8-Lead Plastic Small Outline (MSB) - Narrow, 3.90 mm (.150 In.) Body [SOIC] Atmel Legacy Global Package Code SWB

Note: For the most current package drawings, please see the Microchip Packaging Specification located at <http://www.microchip.com/packaging>

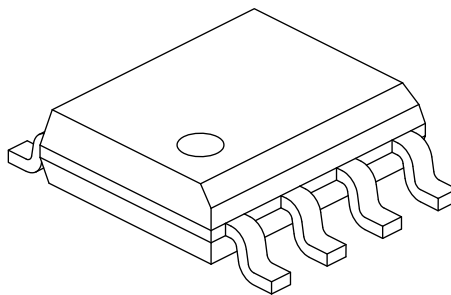

Dimension Limits	Units	MILLIMETERS		
		MIN	NOM	MAX
Number of Pins	N	8		
Pitch	e	1.27 BSC		
Overall Height	A	-	-	1.75
Molded Package Thickness	A2	1.25	-	-
Standoff §	A1	0.10	-	0.25
Overall Width	E	6.00 BSC		
Molded Package Width	E1	3.90 BSC		
Overall Length	D	4.90 BSC		
Chamfer (Optional)	h	0.25	-	0.50
Foot Length	L	0.40	-	1.27
Footprint	L1	1.04 REF		
Foot Angle	φ	0°	-	8°
Lead Thickness	c	0.17	-	0.25
Lead Width	b	0.31	-	0.51
Mold Draft Angle Top	α	5°	-	15°
Mold Draft Angle Bottom	β	5°	-	15°

Notes:

- Pin 1 visual index feature may vary, but must be located within the hatched area.
- § Significant Characteristic
- Dimensions D and E1 do not include mold flash or protrusions. Mold flash or protrusions shall not exceed 0.15mm per side.
- Dimensioning and tolerancing per ASME Y14.5M
BSC: Basic Dimension. Theoretically exact value shown without tolerances.
REF: Reference Dimension, usually without tolerance, for information purposes only.
- Datums A & B to be determined at Datum H.

Microchip Technology Drawing No. C04-057-MSB Rev F Sheet 2 of 2

8-Lead SOIC Package Outline and Recommended Land Pattern



**8-Lead Plastic Small Outline (MSB) - Narrow, 3.90 mm (.150 In.) Body [SOIC]
Atmel Legacy Global Package Code SWB**

Note: For the most current package drawings, please see the Microchip Packaging Specification located at <http://www.microchip.com/packaging>

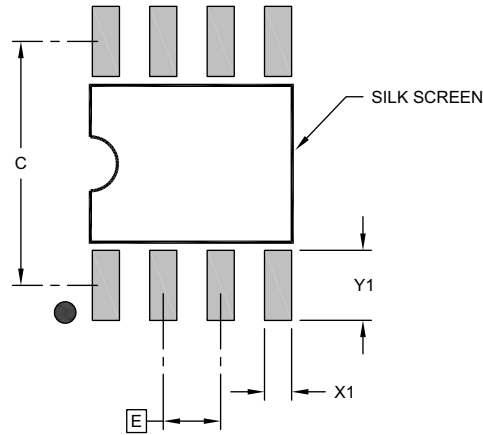

RECOMMENDED LAND PATTERN

Dimension Limits	Units	MILLIMETERS		
		MIN	NOM	MAX
Contact Pitch	E		1.27 BSC	
Contact Pad Spacing	C		5.40	
Contact Pad Width (X8)	X1			0.60
Contact Pad Length (X8)	Y1			1.55

Notes:

1. Dimensioning and tolerancing per ASME Y14.5M
BSC: Basic Dimension. Theoretically exact value shown without tolerances.

Microchip Technology Drawing C04-2057-MSB Rev F

© 2020 Microchip Technology Incorporated

PL133-47

NOTES:

APPENDIX A: REVISION HISTORY**Revision A (April 2022)**

- Converted Micrel document PL133-47 to Microchip data sheet DS20006670A.
- Minor grammatical changes throughout.

PL133-47

NOTES:

PRODUCT IDENTIFICATION SYSTEM

To order or obtain information, e.g., on pricing or delivery, contact your local Microchip representative or sales office.

<u>PART NO.</u>	<u>X</u>	<u>X</u>	<u>X</u>
Device	Package	Temperature Range	Media Type
Device: PL133-47: Low-Power DC to 150 MHz 1:4 Fanout Buffer IC			Examples: a) PL133-47SC Low-Power DC to 150 MHz 1:4 Fanout Buffer IC, SOIC Package, 0°C to +70°C, 100/Tube b) PL133-47SC-R Low-Power DC to 150 MHz 1:4 Fanout Buffer IC, SOIC Package, 0°C to +70°C, 2,500/Reel c) PL133-47SI Low-Power DC to 150 MHz 1:4 Fanout Buffer IC, SOIC Package, -40°C to +85°C, 100/Tube
Package: S = 3.90 mm SOIC (Plastic Small Outline) Package			
Temperature Range: C = 0°C to +70°C (Commercial) I = -40°C to +85°C (Industrial)			
Media Type: (blank) = 100/Tube R = 2,500/Reel			
			Note 1: Tape and Reel identifier only appears in the catalog part number description. This identifier is used for ordering purposes and is not printed on the device package. Check with your Microchip Sales Office for package availability with the Tape and Reel option.

PL133-47

NOTES:

Note the following details of the code protection feature on Microchip products:

- Microchip products meet the specifications contained in their particular Microchip Data Sheet.
- Microchip believes that its family of products is secure when used in the intended manner, within operating specifications, and under normal conditions.
- Microchip values and aggressively protects its intellectual property rights. Attempts to breach the code protection features of Microchip product is strictly prohibited and may violate the Digital Millennium Copyright Act.
- Neither Microchip nor any other semiconductor manufacturer can guarantee the security of its code. Code protection does not mean that we are guaranteeing the product is “unbreakable”. Code protection is constantly evolving. Microchip is committed to continuously improving the code protection features of our products.

This publication and the information herein may be used only with Microchip products, including to design, test, and integrate Microchip products with your application. Use of this information in any other manner violates these terms. Information regarding device applications is provided only for your convenience and may be superseded by updates. It is your responsibility to ensure that your application meets with your specifications. Contact your local Microchip sales office for additional support or, obtain additional support at <https://www.microchip.com/en-us/support/design-help/client-support-services>.

THIS INFORMATION IS PROVIDED BY MICROCHIP "AS IS". MICROCHIP MAKES NO REPRESENTATIONS OR WARRANTIES OF ANY KIND WHETHER EXPRESS OR IMPLIED, WRITTEN OR ORAL, STATUTORY OR OTHERWISE, RELATED TO THE INFORMATION INCLUDING BUT NOT LIMITED TO ANY IMPLIED WARRANTIES OF NON-INFRINGEMENT, MERCHANTABILITY, AND FITNESS FOR A PARTICULAR PURPOSE, OR WARRANTIES RELATED TO ITS CONDITION, QUALITY, OR PERFORMANCE.

IN NO EVENT WILL MICROCHIP BE LIABLE FOR ANY INDIRECT, SPECIAL, PUNITIVE, INCIDENTAL, OR CONSEQUENTIAL LOSS, DAMAGE, COST, OR EXPENSE OF ANY KIND WHATSOEVER RELATED TO THE INFORMATION OR ITS USE, HOWEVER CAUSED, EVEN IF MICROCHIP HAS BEEN ADVISED OF THE POSSIBILITY OR THE DAMAGES ARE FORESEEABLE. TO THE FULLEST EXTENT ALLOWED BY LAW, MICROCHIP'S TOTAL LIABILITY ON ALL CLAIMS IN ANY WAY RELATED TO THE INFORMATION OR ITS USE WILL NOT EXCEED THE AMOUNT OF FEES, IF ANY, THAT YOU HAVE PAID DIRECTLY TO MICROCHIP FOR THE INFORMATION.

Use of Microchip devices in life support and/or safety applications is entirely at the buyer's risk, and the buyer agrees to defend, indemnify and hold harmless Microchip from any and all damages, claims, suits, or expenses resulting from such use. No licenses are conveyed, implicitly or otherwise, under any Microchip intellectual property rights unless otherwise stated.

For information regarding Microchip's Quality Management Systems, please visit www.microchip.com/quality.

Trademarks

The Microchip name and logo, the Microchip logo, Adaptec, AnyRate, AVR, AVR logo, AVR Freaks, BesTime, BitCloud, CryptoMemory, CryptoRF, dsPIC, flexPWR, HELDO, IGLOO, JukeBlox, KeeLoq, Kleer, LANCheck, LinkMD, maXStylus, maXTouch, MediaLB, megaAVR, Microsemi, Microsemi logo, MOST, MOST logo, MPLAB, OptoLyzer, PIC, picoPower, PICSTART, PIC32 logo, PolarFire, Prochip Designer, QTouch, SAM-BA, SenGenuity, SpyNIC, SST, SST Logo, SuperFlash, Symmetricom, SyncServer, Tachyon, TimeSource, tinyAVR, UNI/O, Vectron, and XMEGA are registered trademarks of Microchip Technology Incorporated in the U.S.A. and other countries.

AgileSwitch, APT, ClockWorks, The Embedded Control Solutions Company, EtherSynch, Flashtec, Hyper Speed Control, HyperLight Load, IntelliMOS, Libero, motorBench, mTouch, Powermite 3, Precision Edge, ProASIC, ProASIC Plus, ProASIC Plus logo, QuietWire, SmartFusion, SyncWorld, Temux, TimeCesium, TimeHub, TimePictra, TimeProvider, TrueTime, WinPath, and ZL are registered trademarks of Microchip Technology Incorporated in the U.S.A.

Adjacent Key Suppression, AKS, Analog-for-the-Digital Age, Any Capacitor, AnyIn, AnyOut, Augmented Switching, BlueSky, BodyCom, CodeGuard, CryptoAuthentication, CryptoAutomotive, CryptoCompanion, CryptoController, dsPICDEM, dsPICDEM.net, Dynamic Average Matching, DAM, ECAN, Espresso T1S, EtherGREEN, GridTime, IdealBridge, In-Circuit Serial Programming, ICSP, INICnet, Intelligent Paralleling, Inter-Chip Connectivity, JitterBlocker, Knob-on-Display, maxCrypto, maxView, memBrain, Mindi, MiWi, MPASM, MPF, MPLAB Certified logo, MPLIB, MPLINK, MultiTRAK, NetDetach, NVM Express, NVMe, Omniscient Code Generation, PICDEM, PICDEM.net, PICkit, PICtail, PowerSmart, PureSilicon, QMatrix, REAL ICE, Ripple Blocker, RTAX, RTG4, SAM-ICE, Serial Quad I/O, simpleMAP, SimpliPHY, SmartBuffer, SmartHLS, SMART-I.S., storClad, SQL, SuperSwitcher, SuperSwitcher II, Switchtec, SynchroPHY, Total Endurance, TSHARC, USBCheck, VariSense, VectorBlox, VeriPHY, ViewSpan, WiperLock, XpressConnect, and ZENA are trademarks of Microchip Technology Incorporated in the U.S.A. and other countries.

SQTP is a service mark of Microchip Technology Incorporated in the U.S.A.

The Adaptec logo, Frequency on Demand, Silicon Storage Technology, Symmcom, and Trusted Time are registered trademarks of Microchip Technology Inc. in other countries.

GestIC is a registered trademark of Microchip Technology Germany II GmbH & Co. KG, a subsidiary of Microchip Technology Inc., in other countries.

All other trademarks mentioned herein are property of their respective companies.

© 2022, Microchip Technology Incorporated and its subsidiaries.

All Rights Reserved.

ISBN: 978-1-6683-0273-6



MICROCHIP

Worldwide Sales and Service

AMERICAS

Corporate Office
2355 West Chandler Blvd.
Chandler, AZ 85224-6199
Tel: 480-792-7200
Fax: 480-792-7277
Technical Support:
<http://www.microchip.com/support>
Web Address:
www.microchip.com

Atlanta

Duluth, GA
Tel: 678-957-9614
Fax: 678-957-1455

Austin, TX

Tel: 512-257-3370

Boston

Westborough, MA
Tel: 774-760-0087
Fax: 774-760-0088

Chicago

Itasca, IL
Tel: 630-285-0071
Fax: 630-285-0075

Dallas

Addison, TX
Tel: 972-818-7423
Fax: 972-818-2924

Detroit

Novi, MI
Tel: 248-848-4000

Houston, TX

Tel: 281-894-5983

Indianapolis

Noblesville, IN
Tel: 317-773-8323
Fax: 317-773-5453
Tel: 317-536-2380

Los Angeles

Mission Viejo, CA
Tel: 949-462-9523
Fax: 949-462-9608
Tel: 951-273-7800

Raleigh, NC

Tel: 919-844-7510

New York, NY

Tel: 631-435-6000

San Jose, CA

Tel: 408-735-9110
Tel: 408-436-4270

Canada - Toronto

Tel: 905-695-1980
Fax: 905-695-2078

ASIA/PACIFIC

Australia - Sydney
Tel: 61-2-9868-6733

China - Beijing
Tel: 86-10-8569-7000

China - Chengdu
Tel: 86-28-8665-5511

China - Chongqing
Tel: 86-23-8980-9588

China - Dongguan
Tel: 86-769-8702-9880

China - Guangzhou
Tel: 86-20-8755-8029

China - Hangzhou
Tel: 86-571-8792-8115

China - Hong Kong SAR
Tel: 852-2943-5100

China - Nanjing
Tel: 86-25-8473-2460

China - Qingdao
Tel: 86-532-8502-7355

China - Shanghai
Tel: 86-21-3326-8000

China - Shenyang
Tel: 86-24-2334-2829

China - Shenzhen
Tel: 86-755-8864-2200

China - Suzhou
Tel: 86-186-6233-1526

China - Wuhan
Tel: 86-27-5980-5300

China - Xian
Tel: 86-29-8833-7252

China - Xiamen
Tel: 86-592-2388138

China - Zhuhai
Tel: 86-756-3210040

ASIA/PACIFIC

India - Bangalore
Tel: 91-80-3090-4444

India - New Delhi
Tel: 91-11-4160-8631

India - Pune
Tel: 91-20-4121-0141

Japan - Osaka
Tel: 81-6-6152-7160

Japan - Tokyo
Tel: 81-3-6880-3770

Korea - Daegu
Tel: 82-53-744-4301

Korea - Seoul
Tel: 82-2-554-7200

Malaysia - Kuala Lumpur
Tel: 60-3-7651-7906

Malaysia - Penang
Tel: 60-4-227-8870

Philippines - Manila
Tel: 63-2-634-9065

Singapore
Tel: 65-6334-8870

Taiwan - Hsin Chu
Tel: 886-3-577-8366

Taiwan - Kaohsiung
Tel: 886-7-213-7830

Taiwan - Taipei
Tel: 886-2-2508-8600

Thailand - Bangkok
Tel: 66-2-694-1351

Vietnam - Ho Chi Minh
Tel: 84-28-5448-2100

EUROPE

Austria - Wels
Tel: 43-7242-2244-39
Fax: 43-7242-2244-393

Denmark - Copenhagen
Tel: 45-4485-5910
Fax: 45-4485-2829

Finland - Espoo
Tel: 358-9-4520-820

France - Paris
Tel: 33-1-69-53-63-20
Fax: 33-1-69-30-90-79

Germany - Garching
Tel: 49-8931-9700

Germany - Haan
Tel: 49-2129-3766400

Germany - Heilbronn
Tel: 49-7131-72400

Germany - Karlsruhe
Tel: 49-721-625370

Germany - Munich
Tel: 49-89-627-144-0
Fax: 49-89-627-144-44

Germany - Rosenheim
Tel: 49-8031-354-560

Israel - Ra'anana
Tel: 972-9-744-7705

Italy - Milan
Tel: 39-0331-742611
Fax: 39-0331-466781

Italy - Padova
Tel: 39-049-7625286

Netherlands - Drunen
Tel: 31-416-690399
Fax: 31-416-690340

Norway - Trondheim
Tel: 47-7288-4388

Poland - Warsaw
Tel: 48-22-3325737

Romania - Bucharest
Tel: 40-21-407-87-50

Spain - Madrid
Tel: 34-91-708-08-90
Fax: 34-91-708-08-91

Sweden - Gothenberg
Tel: 46-31-704-60-40

Sweden - Stockholm
Tel: 46-8-5090-4654

UK - Wokingham
Tel: 44-118-921-5800
Fax: 44-118-921-5820

OUR CERTIFICATE

DiGi provide top-quality products and perfect service for customer worldwide through standardization, technological innovation and continuous improvement. DiGi through third-party certification, we stricly control the quality of products and services. Welcome your RFQ to

Email: Info@DiGi-Electronics.com



Tel: +00 852-30501935

RFQ Email: Info@DiGi-Electronics.com

DiGi is a global authorized distributor of electronic components.