

# SY89872UMG Datasheet

[www.digi-electronics.com](http://www.digi-electronics.com)

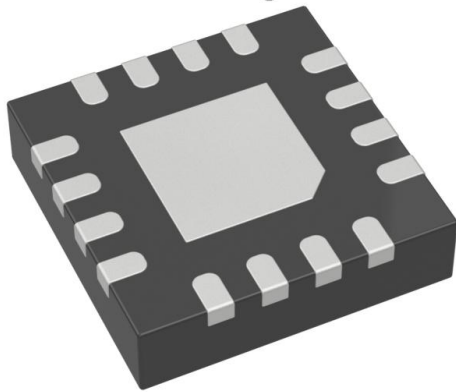

<https://www.DiGi-Electronics.com>

DiGi Electronics Part Number	SY89872UMG-DG
Manufacturer	<a href="#">Microchip Technology</a>
Manufacturer Product Number	SY89872UMG
Description	IC CLK BUFFER 1:3 2GHZ 16MLF
Detailed Description	Clock Fanout Buffer (Distribution), Divider IC 1:3 2 G Hz 16-VFQFN Exposed Pad, 16-MLF®



Tel: +00 852-30501935

RFQ Email: [Info@DiGi-Electronics.com](mailto:Info@DiGi-Electronics.com)

DiGi is a global authorized distributor of electronic components.

## Purchase and inquiry

Manufacturer Product Number:

SY89872UMG

Series:

Precision Edge®

Type:

Fanout Buffer (Distribution), Divider

Ratio - Input:Output:

1:3

Input:

CML, HSTL, LVDS, LVPECL

Frequency - Max:

2 GHz

Operating Temperature:

-40°C ~ 85°C

Package / Case:

16-VFQFN Exposed Pad, 16-MLF®

Base Product Number:

SY89872

Manufacturer:

Microchip Technology

Product Status:

Active

Number of Circuits:

1

Differential - Input:Output:

Yes/Yes

Output:

LVDS

Voltage - Supply:

2.375V ~ 2.625V

Mounting Type:

Surface Mount

Supplier Device Package:

16-MLF® (3x3)

## Environmental & Export classification

RoHS Status:

ROHS3 Compliant

REACH Status:

REACH Unaffected

HTSUS:

8542.39.0001

Moisture Sensitivity Level (MSL):

2 (1 Year)

ECCN:

EAR99



**2.5V, 2GHz ANY DIFF. IN-TO-LVDS  
PROGRAMMABLE CLOCK DIVIDER/  
FANOUT BUFFER W/INTERNAL TERMINATION**

**Precision Edge®  
SY89872U**

## FEATURES

- **Guaranteed AC performance over temperature and voltage:**
  - >2GHz  $f_{MAX}$
  - < 750ps  $t_{PD}$  (matched delay between banks)
  - < 15ps within-device skew
  - < 200ps rise/fall time
- **Low jitter design**
  - 265fs RMS phase jitter
- **Unique input termination and VT pin for DC-coupled and AC-coupled inputs: any differential inputs (LVPECL, LVDS, CML, HSTL)**
- **Precision differential LVDS outputs**
- **Matched delay: all outputs have matched delay, independent of divider setting**
- **TTL/CMOS inputs for select and reset/disable**
- **Two output banks (matched delay)**
  - **Bank A: Buffered copy of input clock (undivided)**
  - **Bank B: Divided output ( $\div 2, \div 4, \div 8, \div 16$ ), two copies**
- **2.5V power supply**
- **Wide operating temperature range:  $-40^{\circ}\text{C}$  to  $+85^{\circ}\text{C}$**
- **Available in 16-pin (3mm x 3mm) QFN package**

## APPLICATIONS

- OC-3 to OC-192 SONET/SDH applications
- Transponders
- Oscillators
- SONET/SDH line cards

## FUNCTIONAL BLOCK DIAGRAM

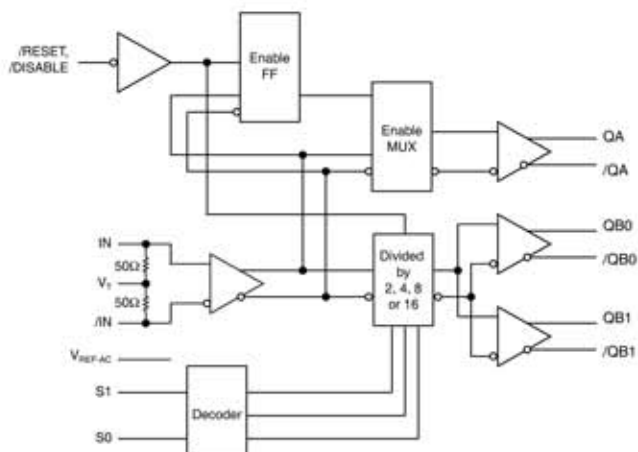

United States Patent No. RE44,134

Precision Edge is a registered trademark of Micrel, Inc.

M9999-082407  
hbwhelp@micrel.com or (408) 955-1690



Precision Edge®

## DESCRIPTION

This 2.5V low-skew, low-jitter, precision LVDS output clock divider accepts any high-speed differential clock input (AC or DC-coupled) CML, LVPECL, HSTL or LVDS and divides down the frequency using a programmable divider ratio to create a frequency-locked, lower speed version of the input clock. The SY89872U includes two output banks. Bank A is an exact copy of the input clock (pass through) with matched propagation delay to Bank B, the divided output bank. Available divider ratios are 2, 4, 8 and 16. In a typical 622MHz clock system this would provide availability of 311MHz, 155MHz, 77MHz or 38MHz auxiliary clock components.

The differential input buffer has a unique internal termination design that allows access to the termination network through a  $V_T$  pin. This feature allows the device to easily interface to different logic standards. A  $V_{REF-AC}$  reference is included for AC-coupled applications.

The SY89872U is part of Micrel's high-speed Precision Edge® timing and distribution family. For 3.3V applications, consider the SY89873L. For applications that require an LVPECL output, consider the SY89872U.

The /RESET input asynchronously resets the divider outputs (Bank B). In the pass-through function (Bank A) the /RESET synchronously enables or disables the outputs on the next falling edge of IN (rising edge of /IN). Refer to the "Timing Diagram."

## TYPICAL APPLICATION

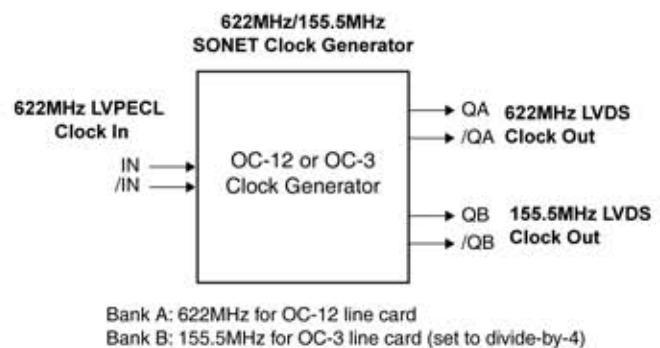

## PACKAGE/ORDERING INFORMATION

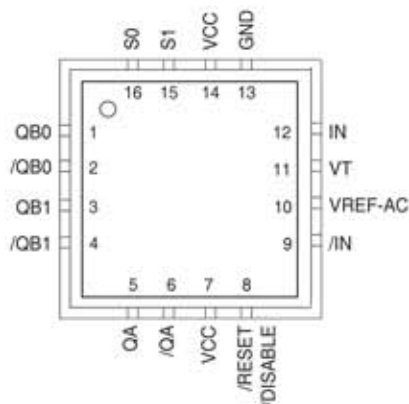

16-Pin QFN

Ordering Information<sup>(1)</sup>

Part Number	Package Type	Operating Range	Package Marking	Lead Finish
SY89872UMG	QFN-16	Industrial	872U with Pb-Free bar line indicator	NiPdAu Pb-Free
SY89872UMGTR <sup>(2)</sup>	QFN-16	Industrial	872U with Pb-Free bar line indicator	NiPdAu Pb-Free

## Notes:

- Contact factory for die availability. Dice are guaranteed at  $T_A = 25^\circ\text{C}$ , DC Electricals only.
- Tape and Reel.

## PIN DESCRIPTION

Pin Number	Pin Name	Pin Function
1, 2, 3, 4	QB0, /QB0 QB1, /QB1	Differential LVDS Compatible Outputs: Divide by 2, 4, 8, 16. Unused outputs must be terminated with $100\Omega$ across the pin (Q, /Q).
5, 6	QA, /QA	Differential LVDS Compatible Undivided Output Clock.
7, 14	VCC	Positive Power Supply: Bypass with $0.1\mu\text{F}/0.01\mu\text{F}$ low ESR capacitors.
8	/RESET, /DISABLE	Output Reset and Output Enable/Disable: Internal $25k\Omega$ pull-up. Input threshold is $V_{CC}/2$ . Logic LOW will reset the divider select, and align Bank A and Bank B edges. In addition, when LOW, Bank A and Bank B will be disabled.
12, 9	IN, /IN	Differential Reference Input Clock: Internal $50\Omega$ termination resistors to $V_T$ input. See "Input Interface Applications" section.
10	VREF-AC	Reference Voltage: Equal to $V_{CC}-1.4\text{V}$ (approx.), and used for AC-coupled applications. Maximum sink/source current is $0.5\text{mA}$ . See "Input Interface Applications" section.
11	VT	Termination Center-Tap: For DC-coupled CML and LVDS inputs, leave this pin floating. See "Input Interface Applications" section.
13	GND	Ground.
15, 16	S1, S0	Select Pins: LVTTTL/CMOS logic levels. Internal $25k\Omega$ pull-up resistor. Logic HIGH if left unconnected (divided by 16 mode). S0 = LSB. Input threshold is $V_{CC}/2$ .

## TRUTH TABLE

/RESET /DISABLE	S1	S0	Bank A Output	Bank B Outputs
1	0	0	Input Clock	Input Clock +2
1	0	1	Input Clock	Input Clock +4
1	1	0	Input Clock	Input Clock +8
1	1	1	Input Clock	Input Clock +16
0	X	X	QA = Low, /QA = High <sup>(1)</sup>	QB0 = Low, /QB0 = High <sup>(2)</sup> QB1 = Low, /QB1 = High <sup>(2)</sup>

**Note 1.** On the next negative transition of the input signal.

**Note 2.** Asynchronous reset/disable function. (See "Timing Diagram")

Micrel, Inc.

**Absolute Maximum Ratings**(Note 1)

Supply Voltage ( $V_{CC}$ )	-0.5V to +6.0V
Input Voltage ( $V_{IN}$ )	-0.5V to $V_{CC}$
LVDS Output Current ( $I_{OUT}$ )	$\pm 10$ mA
Input Current $I_N$ , /IN ( $I_{IN}$ )	$\pm 50$ mA
$V_{REF-AC}$ Input Sink/Source Current ( $I_{VREF-AC}$ ), Note 3	$\pm 2$ mA
Lead Temperature (soldering, 20sec.)	260°C
Storage Temperature ( $T_S$ )	-65°C to +150°C

**Operating Ratings**(Note 2)

Supply Voltage Range	2.375V to 2.625V
Ambient Temperature ( $T_A$ )	-40°C to +85°C
Package Thermal Resistance	
QFN ( $\theta_{JA}$ )	
Still-Air	60°C/W
500lfpm	54°C/W
QFN ( $\psi_{JB}$ ), Note 4	
Junction-to-Board	32°C/W

**Note 1.** Permanent device damage may occur if absolute maximum ratings are exceeded. This is a stress rating only and functional operation is not implied at conditions other than those detailed in the operational sections of this data sheet. Exposure to absolute maximum rating conditions for extended periods may affect device reliability.

**Note 2.** The datasheet limits are not guaranteed if the device is operated beyond the operating ratings.

**Note 3.** Due to the limited drive capability use for input of the same package only.

**Note 4.** Junction-to-board resistance assumes exposed pad is soldered (or equivalent) to the device's most negative potential on the PCB.

**DC ELECTRICAL CHARACTERISTICS**(Note 1, 2)

$T_A = -40^\circ\text{C}$  to  $+85^\circ\text{C}$ ; Unless otherwise stated.

Symbol	Parameter	Condition	Min	Typ	Max	Units
$V_{CC}$	Power Supply Voltage		2.375	2.5	2.625	V
$I_{CC}$	Power Supply Current	No load, max. $V_{CC}$		75	110	mA
$R_{IN}$	Differential Input Resistance (IN-to-/IN)		90	100	110	$\Omega$
$V_{IH}$	Input High Voltage IN, /IN	Note 3	0.1		$V_{CC}+0.3$	V
$V_{IL}$	Input Low Voltage IN, /IN	Note 3	-0.3		$V_{IH}-0.1$	V
$V_{IN}$	Input Voltage Swing	Notes 3, 4	0.1		$V_{CC}$	V
$V_{DIFF\_IN}$	Differential Input Voltage Swing	Notes 3, 4, 5	0.2			V
$ I_{IN} $	Input Current IN, /IN	Note 3			45	mA
$V_{REF-AC}$	Reference Voltage	Note 6	$V_{CC}-1.525$	$V_{CC}-1.425$	$V_{CC}-1.325$	V

**Note 1.** The circuit is designed to meet the DC specifications shown in the above table after thermal equilibrium has been established.

**Note 2.** Specification for packaged product only.

**Note 3.** Due to the internal termination (see "Input Buffer Structure" section) the input current depends on the applied voltages at IN, /IN and  $V_T$  inputs. Do not apply a combination of voltages that causes the input current to exceed the maximum limit!

**Note 4.** See "Timing Diagram" for  $V_{IN}$  definition.  $V_{IN}$  (max.) is specified when  $V_T$  is floating.

**Note 5.** See Figures 1c and 1d for  $V_{DIFF}$  definition.

**Note 6.** Operating using  $V_{IN}$  is limited to AC-coupled PECL or CML applications only. Connect directly to  $V_T$  pin.

Micrel, Inc.

**LVDS OUTPUTS DC ELECTRICAL CHARACTERISTICS**(Note 1, 2) $V_{CC} = 2.5V \pm 5\%$ ;  $T_A = -40^\circ C$  to  $+85^\circ C$ ; Unless otherwise stated.

Symbol	Parameter	Condition	Min	Typ	Max	Units
$V_{OUT}$	Output Voltage Swing	Note 5	250	350	450	mV
$V_{OH}$	Output High Voltage	Note 3			1.475	V
$V_{OL}$	Output Low Voltage	Note 3	0.925			V
$V_{OCM}$	Output Common Mode Voltage	Note 4	1.125		1.375	V
$\Delta V_{OCM}$	Change in Common Mode Voltage		-50		50	mV

**Note 1.** The circuit is designed to meet the DC specifications shown in the above table after thermal equilibrium has been established.**Note 2.** Specification for packaged product only.**Note 3.** Measured as per Figure 1a, 100 $\mu$  across Q and /Q outputs.**Note 4.** Measured as per Figure 1b.**Note 5.** See Figure 1c.**LVTTTL/CMOS INPUTS DC ELECTRICAL CHARACTERISTICS**(Note 1, 2) $V_{CC} = 2.5V \pm 5\%$ ;  $T_A = -40^\circ C$  to  $+85^\circ C$ ; Unless otherwise stated.

Symbol	Parameter	Condition	Min	Typ	Max	Units
$V_{IH}$	Input HIGH Voltage		2.0	-	$V_{CC}$	V
$V_{IL}$	Input LOW Voltage		0	-	0.8	V
$I_{IH}$	Input HIGH Current		-125	-	20	$\mu A$
$I_{IL}$	Input LOW Current		-	-	-300	$\mu A$

**Note 1.** The circuit is designed to meet the DC specifications shown in the above table after thermal equilibrium has been established.**Note 2.** Specification for packaged product only.

Micrel, Inc.

**AC ELECTRICAL CHARACTERISTICS**(Note 1, 2) $V_{CC} = 2.5V \pm 5\%$ ;  $T_A = -40^{\circ}C$  to  $+85^{\circ}C$ ; Unless otherwise stated.

Symbol	Parameter	Condition	Min	Typ	Max	Units
$f_{MAX}$	Maximum Toggle Frequency	Output Swing: $\geq 200mV$	2			GHz
	Maximum Input Frequency	Note 3	3.2			GHz
$t_{PD}$	Differential Propagation Delay IN to Q	Input Swing: $< 400mV$	500	625	750	ps
		Input Swing: $\geq 400mV$	450	575	700	ps
$t_{SKEW}$	Within-Device Skew (differential) (QB0-to-QB1)	Note 4		7	15	ps
	Within-Device Skew (differential) (Bank A-to-Bank B)	Note 4		12	30	ps
	Part-to-Part Skew (differential)	Note 4			250	ps
$t_{rr}$	Reset Recovery Time	Note 5	600			ps
$T_{jitter}$	RMS Phase Jitter	Output = 622MHz Integration Range: 12kHz - 20MHz		265		fs
$t_r, t_f$	Rise / Fall Time (20% to 80%)		70	130	200	ps

**Note 1.** Measured with 400mV input signal, 50% duty cycle. 100 $\Omega$  termination between Q and /Q, unless otherwise stated.**Note 2.** Specification packaged product only.**Note 3.** Bank A (pass-through) maximum frequency is limited by the output stage. Bank B (input-to-output +2, +4, +8, +16) can accept an input frequency  $> 3GHz$ , while Bank A will be slew rate limited.**Note 4.** Skew is measured between outputs under identical transitions.**Note 5.** See "Timing Diagram."

**LVDS OUTPUT**

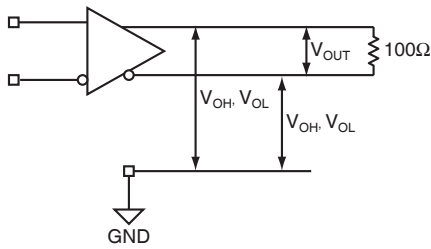

Figure 1a. LVDS Differential Measurement

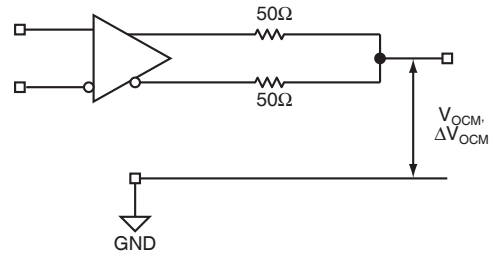

Figure 1b. LVDS Common Mode Measurement

**DEFINITION OF SINGLE-ENDED AND DIFFERENTIAL SWING**



Figure 1c. Single-Ended Swing

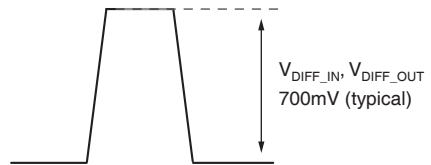
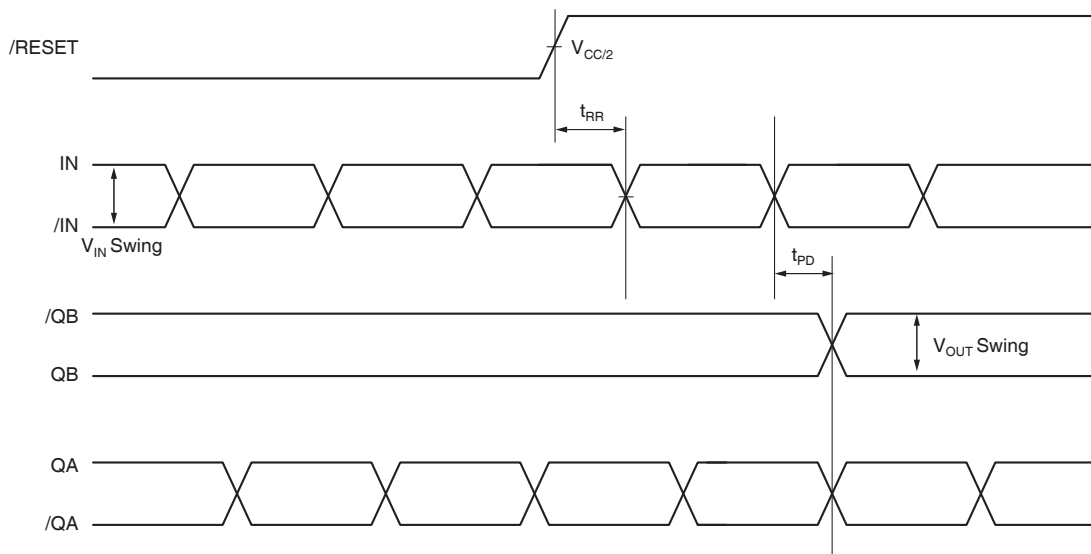

Figure 1d. Differential Swing

**TIMING DIAGRAM**





**TYPICAL OPERATING CHARACTERISTICS**

$V_{CC} = 2.5V$ ,  $V_{IN} = 400mV$ ,  $T_A = 25^{\circ}C$ , unless otherwise stated.

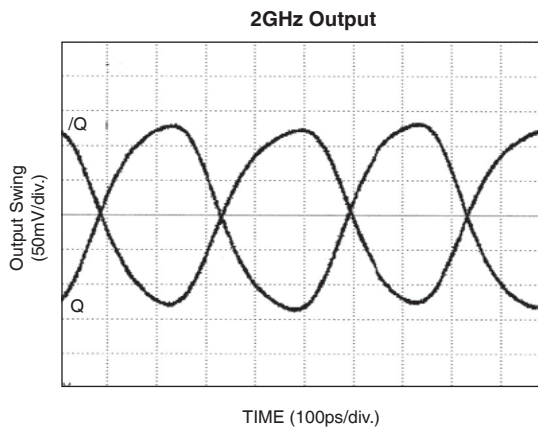
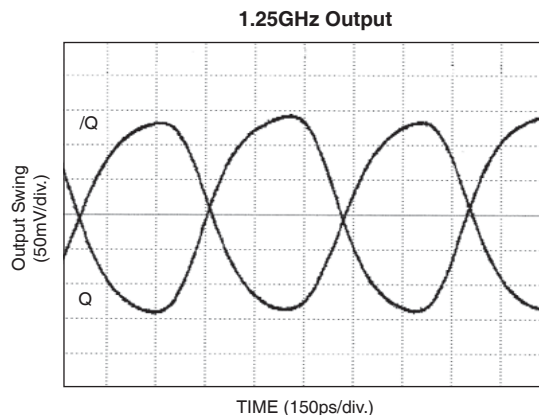
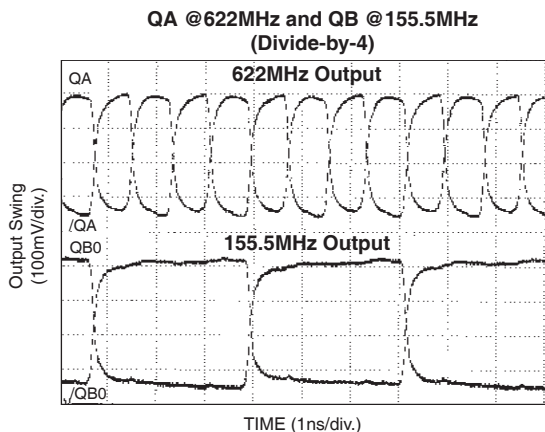
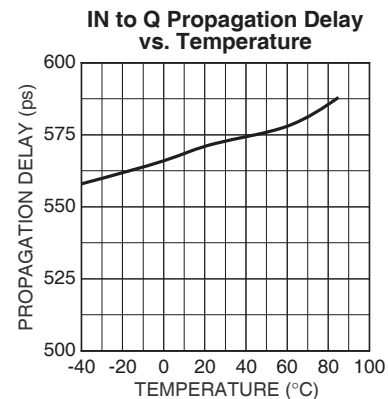
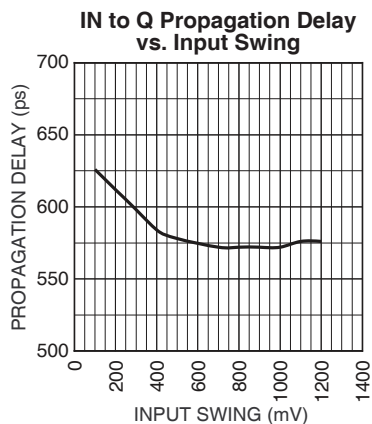
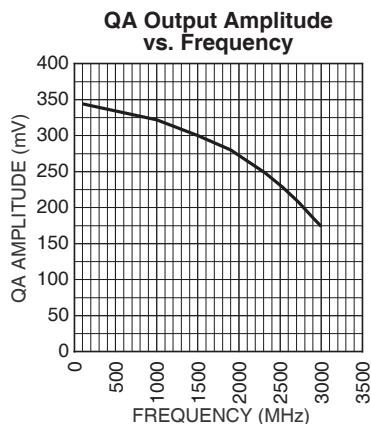

**INPUT BUFFER STRUCTURE**

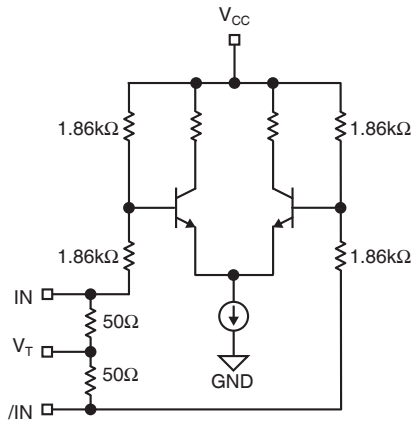

**Figure 2a. Simplified Differential Input Buffer**

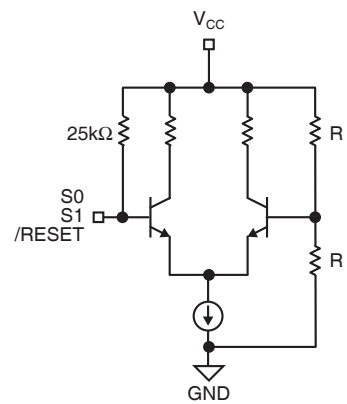

**Figure 2b. Simplified TTL/CMOS Input Buffer**

## INPUT INTERFACE APPLICATIONS

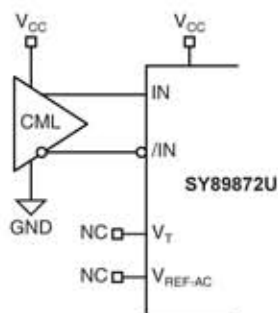

Figure 3a. DC-Coupled CML Input Interface

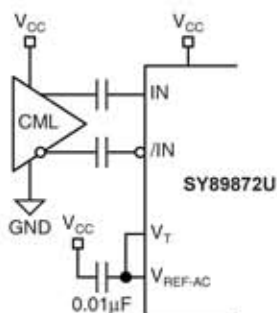

Figure 3b. AC-Coupled CML Input Interface

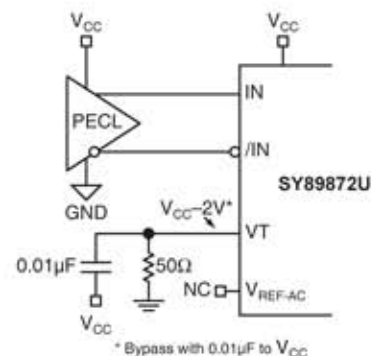

Figure 3c. DC-Coupled PECL Input Interface

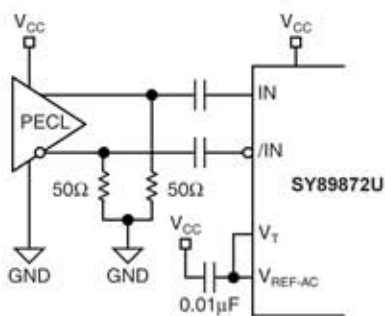

Figure 3d. AC-Coupled PECL Input Interface

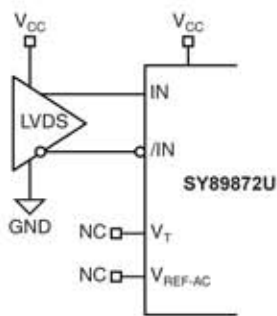

Figure 3e. LVDS Input Interface

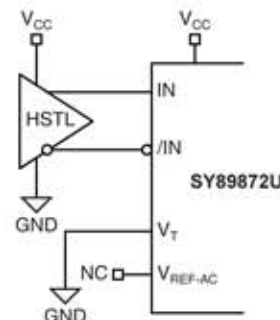
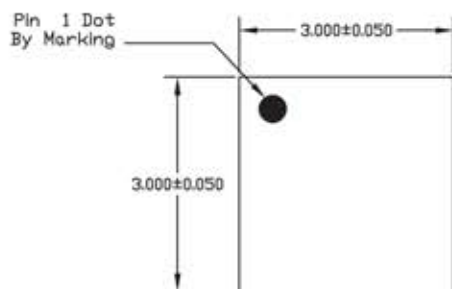

Figure 3f. HSTL Input Interface

## RELATED PRODUCT AND SUPPORT DOCUMENTATION

Part Number	Function	Data Sheet Link
SY89871U	2.5GHz Any Diff. In-to-LVPECL Programmable Clock Divider/Fanout Buffer w/Internal Termination	<a href="http://www.micrel.com/product-info/products/sy89871u.shtml">http://www.micrel.com/product-info/products/sy89871u.shtml</a>
SY89873L	3.3V, 2GHz Any Diff. In-to-LVDS Programmable Clock Divider/Fanout Buffer	<a href="http://www.micrel.com/product-info/products/sy89873l.shtml">http://www.micrel.com/product-info/products/sy89873l.shtml</a>
HBW Solutions	New Products and Applications	<a href="http://www.micrel.com/product-info/products/solutions.shtml">http://www.micrel.com/product-info/products/solutions.shtml</a>

Micrel, Inc.

**16-PIN QFN (QFN-16)**

TOP VIEW

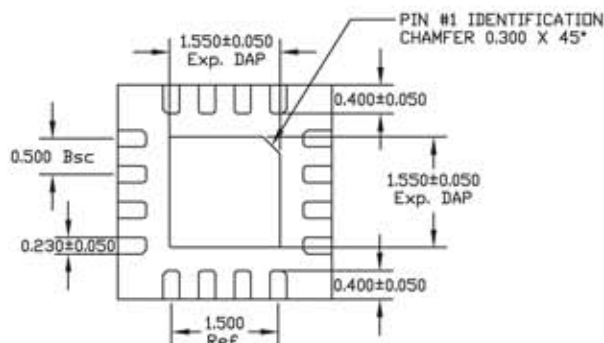

BOTTOM VIEW

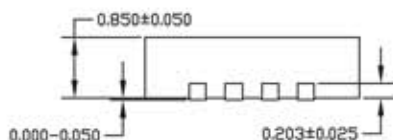

SIDE VIEW

## NOTE:

1. ALL DIMENSIONS ARE IN MILLIMETERS.
2. MAX. PACKAGE WARPAGE IS 0.05 mm.
3. MAXIMUM ALLOWABLE BURRS IS 0.076 mm IN ALL DIRECTIONS.
4. PIN #1 ID ON TOP WILL BE LASER/INK MARKED.

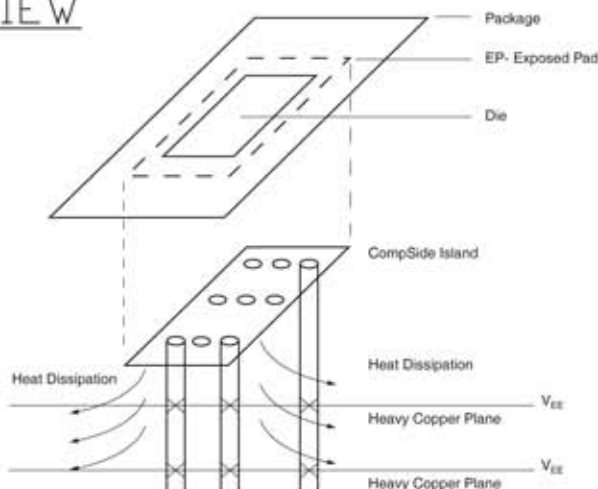

**PCB Thermal Consideration for 16-Pin QFN Package**  
(Always solder, or equivalent, the exposed pad to the PCB)

**Package Notes:**

- Note 1.** Package meets Level 2 moisture sensitivity classification, and is shipped in dry-pack form.  
**Note 2.** Exposed pads must be soldered to a ground for proper thermal management.

**MICREL, INC. 2180 FORTUNE DRIVE SAN JOSE, CA 95131 USA**

TEL + 1 (408) 944-0800 FAX + 1 (408) 944-0970 WEB <http://www.micrel.com>

The information furnished by Micrel in this datasheet is believed to be accurate and reliable. However, no responsibility is assumed by Micrel for its use. Micrel reserves the right to change circuitry and specifications at any time without notification to the customer.

Micrel Products are not designed or authorized for use as components in life support appliances, devices or systems where malfunction of a product can reasonably be expected to result in personal injury. Life support devices or systems are devices or systems that (a) are intended for surgical implant into the body or (b) support or sustain life, and whose failure to perform can be reasonably expected to result in a significant injury to the user. A Purchaser's use or sale of Micrel Products for use in life support appliances, devices or systems is at Purchaser's own risk and Purchaser agrees to fully indemnify Micrel for any damages resulting from such use or sale.

© 2005 Micrel, Incorporated.

## OUR CERTIFICATE

DiGi provide top-quality products and perfect service for customer worldwide through standardization, technological innovation and continuous improvement. DiGi through third-party certification, we stricly control the quality of products and services. Welcome your RFQ to

Email: [Info@DiGi-Electronics.com](mailto:Info@DiGi-Electronics.com)



Tel: +00 852-30501935

RFQ Email: [Info@DiGi-Electronics.com](mailto:Info@DiGi-Electronics.com)

DiGi is a global authorized distributor of electronic components.