

SIM6893M Datasheet

www.digi-electronics.com



<https://www.DiGi-Electronics.com>

DiGi Electronics Part Number	SIM6893M-DG
Manufacturer	Sanken Electric USA Inc.
Manufacturer Product Number	SIM6893M
Description	IPM - HIGH VOLTAGE 3 PHASE MOTOR
Detailed Description	Multiphase Motor Driver Power MOSFET Parallel 40 -DIP LF2971

This model SIM6893M is available at DiGi Electronics.

DiGi Electronics offers a global database of semiconductor and electronic component datasheets.

We welcome your inquiries regarding pricing, lead time, or other product-related questions.

 [Request a Quote](#)

 [Datasheet Search](#)



Tel: +00 852-30501935

RFQ Email: Info@DiGi-Electronics.com

DiGi is a global authorized distributor of electronic components.

Purchase and inquiry

Manufacturer Product Number:

SIM6893M

Series:

-

Motor Type - Stepper:

Multiphase

Function:

Driver - Fully Integrated, Control and Power Stage

Interface:

Parallel

Step Resolution:

-

Current - Output:

5A

Voltage - Load:

400V

Mounting Type:

Through Hole

Supplier Device Package:

40-DIP LF2971

Manufacturer:

Sanken Electric USA Inc.

Product Status:

Active

Motor Type - AC, DC:

Brushless DC (BLDC)

Output Configuration:

Half Bridge (3)

Technology:

Power MOSFET

Applications:

Fan Motor Driver

Voltage - Supply:

13.5V ~ 16.5V

Operating Temperature:

-30°C ~ 100°C

Package / Case:

40-DIP (0.657", 16.70mm), 29 Leads

Base Product Number:

SIM6893

Environmental & Export classification

RoHS Status:

ROHS3 Compliant

ECCN:

EAR99

Moisture Sensitivity Level (MSL):

1 (Unlimited)

HTSUS:

8542.39.0001

600 V High Voltage 3-phase Motor Drivers

SIM689xM Series

Data Sheet

Description

The SIM689xM series are high voltage 3-phase motor drivers in which transistors, pre-drive circuits, and bootstrap circuits (diodes and resistors) are highly integrated. These products can optimally control the inverter systems of low- to medium-capacity motors that require universal input standards.

Features

- Pb-free (RoHS Compliant)
- Temperature Sensing Function
- Built-in Bootstrap Diodes with Current Limiting Resistors (60 Ω)
- CMOS-compatible Input (3.3 V or 5 V)
- Isolation Voltage: 1500 V (for 1 min)
UL-recognized Component (File No.: E118037)
- Fault Signal Output at Protection Activation (FO Pin)
- Protections Include:
 - Overcurrent Protection (OCP): Auto-restart
 - Undervoltage Lockout for Power Supply High-side (UVLO_VB): Auto-restart
 - Low-side (UVLO_VCC): Auto-restart
 - Thermal Shutdown (TSD): Auto-restart

Typical Application (SIM6891MD)

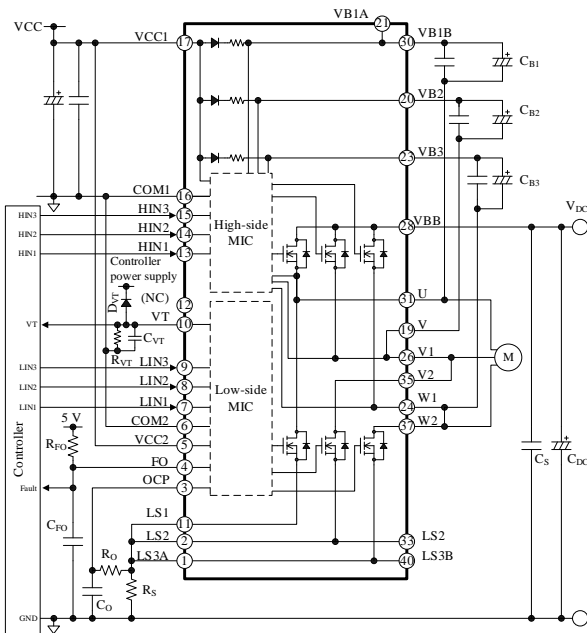

Package

DIP40

Mold Dimensions: 36.0 mm × 14.8 mm × 4.0 mm

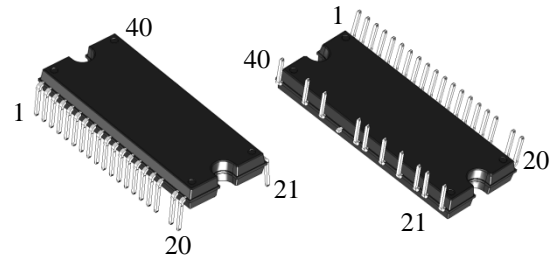

Leadform 2971

Not to scale

Selection Guide

- Breakdown Voltage: 600 V

I _O	Part Number	Feature
2.5 A	SIM6891MD	Power MOSFET, low switching dissipation
2.5 A	SIM6891MDN*	Power MOSFET, noise reduction
5 A	SIM6893M	Power MOSFET
3 A	SIM6896M	IGBT with FRD
5 A	SIM6892M	IGBT with FRD, low switching dissipation
5 A	SIM6895M	IGBT with FRD, noise reduction

* Under development

Applications

For motor drives such as:

- Refrigerator Compressor Motor
- Fan Motor and Pump Motor for Washer and Dryer
- Fan Motor for Air Conditioner
- Fan Motor for Air Purifier

SIM689xM Series**Contents**

Description	1
Contents	2
1. Absolute Maximum Ratings	4
2. Recommended Operating Conditions	5
3. Electrical Characteristics	6
3.1 Characteristics of Control Parts	6
3.2 Bootstrap Diode Characteristics	7
3.3 Thermal Resistance Characteristics	8
3.4 Transistor Characteristics	9
3.4.1 SIM6891MD	9
3.4.2 SIM6891MDN	10
3.4.3 SIM6892M	10
3.4.4 SIM6893M	11
3.4.5 SIM6895M	11
3.4.6 SIM6896M	12
4. Mechanical Characteristics	13
5. Insulation Distance	13
6. Truth Table	14
7. Block Diagrams	15
8. Pin Configuration Definitions	16
9. Typical Applications	17
10. Physical Dimensions	18
11. Marking Diagram	20
12. Functional Descriptions	21
12.1 Turning On and Off the IC	21
12.2 Pin Descriptions	21
12.2.1 U, V, V1, V2, W1, and W2	21
12.2.2 VB1A, VB1B, VB2, and VB3	21
12.2.3 VCC1 and VCC2	22
12.2.4 COM1 and COM2	23
12.2.5 HIN1, HIN2, and HIN3; LIN1, LIN2, and LIN3	23
12.2.6 VBB	24
12.2.7 LS1, LS2, LS3A, and LS3B	24
12.2.8 OCP	24
12.2.9 FO	24
12.2.10 VT	24
12.3 Temperature Sensing Function	24
12.4 Protection Functions	25
12.4.1 Fault Signal Output	25
12.4.2 Undervoltage Lockout for Power Supply (UVLO)	25
12.4.3 Overcurrent Protection (OCP)	26
12.4.4 Thermal Shutdown (TSD)	27
13. Design Notes	28
13.1 PCB Pattern Layout	28
13.2 Considerations in Heatsink Mounting	28
13.3 Considerations in IC Characteristics Measurement	29
14. Calculating Power Losses and Estimating Junction Temperatures	30
14.1 IGBT	30
14.1.1 IGBT Steady-state Loss, P_{ON}	30

SIM689xM Series

14.1.2	IGBT Switching Loss, P_{sw} -----	30
14.1.3	Estimating Junction Temperature of IGBT-----	31
14.1.4	Freewheeling Diode Steady-state Loss, P_F -----	31
14.1.5	Estimating Junction Temperature of Freewheeling Diode-----	31
14.2	Power MOSFET-----	32
14.2.1	Power MOSFET Steady-state Loss, P_{RON} -----	32
14.2.2	Power MOSFET Switching Loss, P_{sw} -----	32
14.2.3	Body Diode Steady-state Loss, P_{SD} -----	32
14.2.4	Estimating Junction Temperature of Power MOSFET-----	33
15.	Performance Curves-----	34
15.1	Performance Curves of Control Parts-----	34
15.2	Transient Thermal Resistance Curves-----	39
15.3	Performance Curves of Output Parts-----	41
15.3.1	Output Transistor Performance Curves-----	41
15.3.2	Switching Loss Curves-----	43
15.4	Allowable Effective Current Curves-----	46
15.4.1	SIM6891MD-----	46
15.4.2	SIM6891MDN-----	47
15.4.3	SIM6893M-----	48
15.4.4	SIM6896M-----	49
15.4.5	SIM6892M-----	50
15.4.6	SIM6895M-----	51
15.5	Short Circuit SOAs (Safe Operating Areas)-----	52
16.	Pattern Layout Example-----	53
17.	Typical Motor Driver Application-----	55
	Important Notes-----	56

SIM689xM Series

1. Absolute Maximum Ratings

Current polarities are defined as follows: current going into the IC (sinking) is positive current (+); current coming out of the IC (sourcing) is negative current (-).

Unless specifically noted, $T_A = 25\text{ }^\circ\text{C}$, COM1 = COM2 = COM.

Parameter	Symbol	Conditions	Rating	Unit	Remarks
Main Supply Voltage (DC) ⁽¹⁾	V_{DC}	VBB-LSx	450	V	SIM6892M SIM6895M SIM6896M
Main Supply Voltage (Surge) ⁽¹⁾	$V_{DC(SURGE)}$	VBB-LSx	500	V	SIM6892M SIM6895M SIM6896M
IGBT / Power MOSFET Breakdown Voltage	V_{DSS}	$V_{CC} = 15\text{ V}$, $I_D = 100\text{ }\mu\text{A}$, $V_{IN} = 0\text{ V}$	600	V	SIM6891MD SIM6891MDN SIM6893M
	V_{CES}	$V_{CC} = 15\text{ V}$, $I_C = 1\text{ mA}$, $V_{IN} = 0\text{ V}$	600	V	SIM6892M SIM6895M SIM6896M
Logic Supply Voltage	V_{BS}	VB1B-U, VB2-V, VB3-W1	20	V	
Output Current ⁽²⁾	I_O	$T_C = 25\text{ }^\circ\text{C}$, $T_J < 150\text{ }^\circ\text{C}$	2.5	A	SIM6891MD SIM6891MDN
			3		SIM6896M
			5		SIM6892M SIM6893M SIM6895M
Output Current (Pulse)	I_{OP}	$T_C = 25\text{ }^\circ\text{C}$, $V_{CC} = 15\text{ V}$, pulse width $\leq 100\text{ }\mu\text{s}$, single pulse	3.75	A	SIM6891MD SIM6891MDN
			4.5		SIM6896M
			7.5		SIM6892M SIM6893M SIM6895M
Input Voltage	V_{IN}	HINx-COM, LINx-COM	-0.5 to 7	V	
FO Pin Voltage	V_{FO}	FO-COM	-0.5 to 7	V	
OCP Pin Voltage	V_{OCP}	OCP-COM	-0.5 to 7	V	
LSx Pin Voltage (DC)	$V_{LS(DC)}$	LSx-COM	-0.5 to 7	V	
LSx Pin Voltage (Surge)	$V_{LS(SURGE)}$	LSx-COM	-4 to 7	V	
Operating Case Temperature ⁽³⁾	$T_{C(OP)}$		-30 to 100	$^\circ\text{C}$	
Junction Temperature ⁽⁴⁾	T_J		150	$^\circ\text{C}$	
Storage Temperature	T_{STG}		-40 to 150	$^\circ\text{C}$	
Isolation Voltage ⁽⁵⁾	$V_{ISO(RMS)}$	Between surface of the case and each pin; AC, 60 Hz, 1 min	1500	V	

⁽¹⁾ Defined for the IGBT-embedded device only.

⁽²⁾ Should be derated depending on an actual case temperature. See Section 15.4.

⁽³⁾ Refers to a case temperature measured during IC operation.

⁽⁴⁾ Refers to the junction temperature of each chip built in the IC, including the control MICs, transistors, and freewheeling diodes.

⁽⁵⁾ Refers to voltage conditions to be applied between all of the pins and the case. All the pins have to be shorted.

SIM689xM Series

2. Recommended Operating Conditions

Unless specifically noted, COM1 = COM2 = COM.

Parameter	Symbol	Conditions	Min.	Typ.	Max.	Unit	Remarks
Main Supply Voltage	V_{DC}	VBB-COM	—	300	400	V	
Logic Supply Voltage	V_{CC}	VCCx-COM	13.5	15.0	16.5	V	
	V_{BS}	VB1B-U, VB2-V, VB3-W1	13.5	—	16.5	V	
Input Voltage (HINx, LINx, OCP)	V_{IN}		0	—	5.5	V	
Minimum Input Pulse Width	$t_{IN(MIN)ON}$		0.5	—	—	μ s	
	$t_{IN(MIN)OFF}$		0.5	—	—	μ s	
Dead Time of Input Signal	t_{DEAD}		1.5	—	—	μ s	
FO Pin Pull-up Voltage	V_{FO}		3.0	—	5.5	V	
FO Pin Pull-up Resistor	R_{FO}		3.3	—	10	k Ω	
FO Pin Noise Filter Capacitor	C_{FO}		0.001	—	0.01	μ F	
Bootstrap Capacitor	C_{BOOT}		1	—	220	μ F	
VT Pin Pull-down Resistor ⁽¹⁾	R_{VT}		100	—	—	k Ω	
VT Pin Capacitor	C_{VT}		0.001	—	0.01	μ F	
Shunt Resistor ⁽²⁾	R_S	$I_{OP} \leq 3.75$ A	144	—	—	m Ω	SIM6891MD SIM6891MDN
		$I_{OP} \leq 4.5$ A	120	—	—		SIM6896M
		$I_{OP} \leq 7.5$ A	72	—	—		SIM6892M SIM6893M SIM6895M
RC Filter Resistor	R_O		—	—	100	Ω	
RC Filter Capacitor	C_O		1000	—	2200	pF	
PWM Carrier Frequency	f_C		—	—	20	kHz	
Operating Case Temperature	$T_{C(OP)}$		—	—	100	$^{\circ}$ C	

⁽¹⁾ Refers to a combined resistance with the input impedance of the microcontroller.

⁽²⁾ Should be a low-inductance resistor.

SIM689xM Series

3. Electrical Characteristics

Current polarities are defined as follows: current going into the IC (sinking) is positive current (+); current coming out of the IC (sourcing) is negative current (-).

Unless specifically noted, $T_A = 25\text{ }^\circ\text{C}$, $V_{CC} = 15\text{ V}$, $\text{COM1} = \text{COM2} = \text{COM}$.

3.1 Characteristics of Control Parts

Parameter	Symbol	Conditions	Min.	Typ.	Max.	Unit	Remarks
Power Supply Operation							
Low-side Logic Operation Start Voltage	$V_{CC(\text{ON})}$	$V_{CCx}\text{-COM}$	10.5	11.5	12.5	V	
Low-side Logic Operation Stop Voltage	$V_{CC(\text{OFF})}$	$V_{CCx}\text{-COM}$	10.0	11.0	12.0	V	
High-side Logic Operation Start Voltage	$V_{BS(\text{ON})}$	VB1B-U, VB2-V, VB3-W1	9.5	10.5	11.5	V	
High-side Logic Operation Stop Voltage	$V_{BS(\text{OFF})}$	VB1B-U, VB2-V, VB3-W1	9.0	10.0	11.0	V	
Logic Supply Current	I_{CC}	Total sink current of the VCC1 and VCC2 pins.	—	2.0	—	mA	
	I_{BS}	VB1B-U or VB2-V or VB3-W1; $HIN_x = 5\text{ V}$; VB_x pin current in 1-phase operation	—	85	170	μA	
Input Signal							
High Level Input Threshold Voltage (HIN_x, LIN_x)	V_{IH}		—	2.0	2.5	V	
Low Level Input Threshold Voltage (HIN_x, LIN_x)	V_{IL}		1.0	1.5	—	V	
High Level Input Current (HIN_x, LIN_x)	I_{IH}	$V_{IN} = 5\text{ V}$	—	230	500	μA	
Low Level Input Current (HIN_x, LIN_x)	I_{IL}	$V_{IN} = 0\text{ V}$	—	—	2	μA	
Fault Signal Output							
FO Pin Voltage at Fault Signal Output	V_{FOL}	$V_{FO} = 5\text{ V}$, $R_{FO} = 10\text{ k}\Omega$	0	—	0.5	V	
FO Pin Voltage in Normal Operation	V_{FOH}	$V_{FO} = 5\text{ V}$, $R_{FO} = 10\text{ k}\Omega$	4.8	—	—	V	
Protection							
OCP Threshold Voltage	V_{TRIP}		0.46	0.50	0.54	V	
OCP Hold Time	t_p		5.0	10.0	—	ms	
OCP Blanking Time	$t_{BK(\text{OCP})}$		—	2	—	μs	
Temperature Sensing Voltage*	V_T	$T_{J(\text{MIC})} = 125\text{ }^\circ\text{C}$	2.997	3.155	3.313	V	
TSD Operating Temperature*	T_{DH}		135	150	165	$^\circ\text{C}$	
TSD Releasing Temperature*	T_{DL}		105	120	135	$^\circ\text{C}$	

* Determined by the junction temperature of the control parts, but not of the output transistors.

SIM689xM Series

3.2 Bootstrap Diode Characteristics

Parameter	Symbol	Conditions	Min.	Typ.	Max.	Unit	Remarks
Bootstrap Diode Leakage Current	I_{LBD}	$V_R = 600 \text{ V}$	—	—	10	μA	
Bootstrap Diode Forward Voltage	V_{FB}	$I_{FB} = 0.15 \text{ A}$	—	1.0	1.3	V	
Bootstrap Diode Series Resistor	R_B		45	60	75	Ω	

SIM689xM Series

3.3 Thermal Resistance Characteristics

Parameter	Symbol	Conditions	Min.	Typ.	Max.	Unit	Remarks
Junction-to-Case Thermal Resistance ⁽¹⁾	R_{J-C}	All power MOSFETs operating	—	—	3.6	°C/W	SIM6893M SIM6891MD SIM6891MDN
	$R_{(J-C)Q}$ ⁽²⁾	All IGBTs operating	—	—	3.6	°C/W	SIM6892M SIM6895M SIM6896M
	$R_{(J-C)F}$ ⁽³⁾	All freewheeling diodes operating	—	—	4.2	°C/W	SIM6892M SIM6895M SIM6896M
Junction-to-Ambient Thermal Resistance	R_{J-A}	All power MOSFETs operating	—	—	25	°C/W	SIM6893M SIM6891MD SIM6891MDN
	$R_{(J-A)Q}$	All IGBTs operating	—	—	25	°C/W	SIM6892M SIM6895M SIM6896M
	$R_{(J-A)F}$	All freewheeling diodes operating	—	—	29	°C/W	SIM6892M SIM6895M SIM6896M

⁽¹⁾ Refers to a case temperature at the measurement point described in Figure 3-1, below.

⁽²⁾ Refers to steady-state thermal resistance between the junction of the built-in transistors and the case. For transient thermal characteristics, see Section 15.2.

⁽³⁾ Refers to steady-state thermal resistance between the junction of the built-in freewheeling diodes and the case.

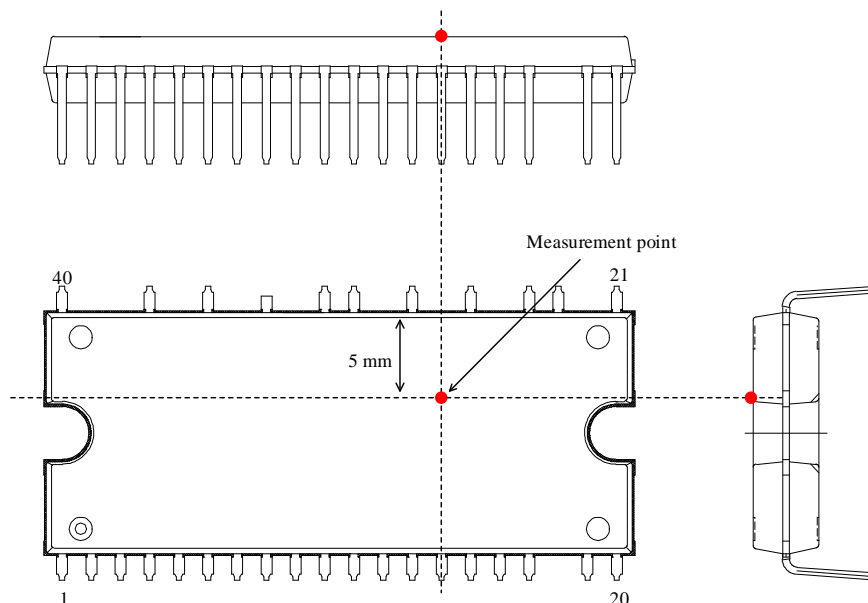

Figure 3-1. Case Temperature Measurement Point

SIM689xM Series

3.4 Transistor Characteristics

Figure 3-2 provides the definitions of switching characteristics described in this and the following sections. The SIM6891MD, SIM6891MDN, and SIM6893M are ICs having built-in power MOSFETs; the SIM6892M, SIM6895M, and SIM6896M are ICs incorporating IGBTs and freewheeling diodes.

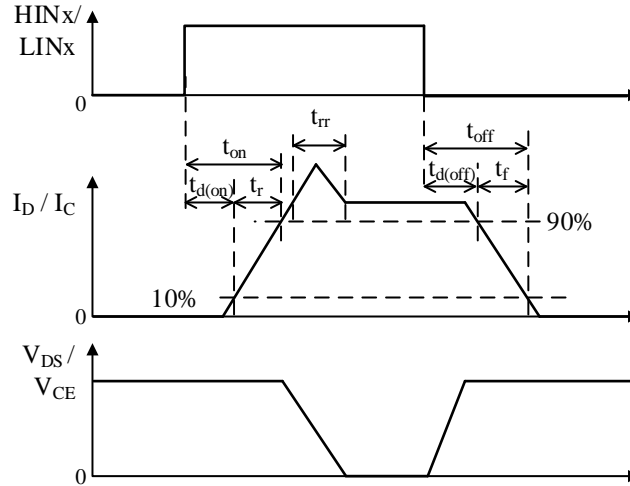

Figure 3-2. Switching Characteristics Definitions

3.4.1 SIM6891MD

Parameter	Symbol	Conditions	Min.	Typ.	Max.	Unit
Drain-to-Source Leakage Current	I_{DSS}	$V_{DS} = 600 \text{ V}$, $V_{IN} = 0 \text{ V}$	—	—	100	μA
Drain-to-Source On-resistance	$R_{DS(ON)}$	$I_D = 1.25 \text{ A}$, $V_{IN} = 5 \text{ V}$	—	2.0	2.5	Ω
Source-to-Drain Diode Forward Voltage	V_{SD}	$I_{SD} = 1.25 \text{ A}$, $V_{IN} = 0 \text{ V}$	—	1.0	1.5	V
High-side Switching						
Source-to-Drain Diode Reverse Recovery Time	t_{rr}	$V_{DC} = 300 \text{ V}$, $I_D = 1.25 \text{ A}$, $V_{IN} = 0 \rightarrow 5 \text{ V}$ or $5 \rightarrow 0 \text{ V}$, $T_J = 25 \text{ }^\circ\text{C}$, inductive load	—	100	—	ns
Turn-on Delay Time	$t_{d(ON)}$		—	425	—	ns
Rise Time	t_r		—	50	—	ns
Turn-off Delay Time	$t_{d(OFF)}$		—	350	—	ns
Fall Time	t_f		—	35	—	ns
Low-side Switching						
Source-to-Drain Diode Reverse Recovery Time	t_{rr}	$V_{DC} = 300 \text{ V}$, $I_D = 1.25 \text{ A}$, $V_{IN} = 0 \rightarrow 5 \text{ V}$ or $5 \rightarrow 0 \text{ V}$, $T_J = 25 \text{ }^\circ\text{C}$, inductive load	—	100	—	ns
Turn-on Delay Time	$t_{d(ON)}$		—	425	—	ns
Rise Time	t_r		—	55	—	ns
Turn-off Delay Time	$t_{d(OFF)}$		—	365	—	ns
Fall Time	t_f		—	20	—	ns

SIM689xM Series

3.4.2 SIM6891MDN

Parameter	Symbol	Conditions	Min.	Typ.	Max.	Unit
Drain-to-Source Leakage Current	I_{DSS}	$V_{DS} = 600\text{ V}, V_{IN} = 0\text{ V}$	—	—	100	μA
Drain-to-Source On-resistance	$R_{DS(ON)}$	$I_D = 1.25\text{ A}, V_{IN} = 5\text{ V}$	—	2.0	2.5	Ω
Source-to-Drain Diode Forward Voltage	V_{SD}	$I_{SD} = 1.25\text{ A}, V_{IN} = 0\text{ V}$	—	1.0	1.5	V
High-side Switching						
Source-to-Drain Diode Reverse Recovery Time	t_{rr}	$V_{BB} = 300\text{ V}, I_D = 1.25\text{ A}, V_{IN} = 0 \rightarrow 5\text{ V or } 5 \rightarrow 0\text{ V}, T_J = 25\text{ }^\circ\text{C},$ inductive load	—	140	—	ns
Turn-on Delay Time	$t_{d(ON)}$		—	690	—	ns
Rise Time	t_r		—	115	—	ns
Turn-off Delay Time	$t_{d(OFF)}$		—	350	—	ns
Fall Time	t_f		—	25	—	ns
Low-side Switching						
Source-to-Drain Diode Reverse Recovery Time	t_{rr}	$V_{BB} = 300\text{ V}, I_D = 1.25\text{ A}, V_{IN} = 0 \rightarrow 5\text{ V or } 5 \rightarrow 0\text{ V}, T_J = 25\text{ }^\circ\text{C},$ inductive load	—	165	—	ns
Turn-on Delay Time	$t_{d(ON)}$		—	690	—	ns
Rise Time	t_r		—	115	—	ns
Turn-off Delay Time	$t_{d(OFF)}$		—	380	—	ns
Fall Time	t_f		—	25	—	ns

3.4.3 SIM6892M

Parameter	Symbol	Conditions	Min.	Typ.	Max.	Unit
Collector-to-Emitter Leakage Current	I_{CES}	$V_{CE} = 600\text{ V}, V_{IN} = 0\text{ V}$	—	—	1	mA
Collector-to-Emitter Saturation Voltage	$V_{CE(SAT)}$	$I_C = 5.0\text{ A}, V_{IN} = 5\text{ V}$	—	1.75	2.20	V
Diode Forward Voltage	V_F	$I_F = 5.0\text{ A}, V_{IN} = 0\text{ V}$	—	2.0	2.4	V
High-side Switching						
Diode Reverse Recovery Time	t_{rr}	$V_{DC} = 300\text{ V}, I_C = 5.0\text{ A}, V_{IN} = 0 \rightarrow 5\text{ V or } 5 \rightarrow 0\text{ V}, T_J = 25\text{ }^\circ\text{C},$ inductive load	—	100	—	ns
Turn-on Delay Time	$t_{d(ON)}$		—	530	—	ns
Rise Time	t_r		—	110	—	ns
Turn-off Delay Time	$t_{d(OFF)}$		—	740	—	ns
Fall Time	t_f		—	210	—	ns
Low-side Switching						
Diode Reverse Recovery Time	t_{rr}	$V_{DC} = 300\text{ V}, I_C = 5.0\text{ A}, V_{IN} = 0 \rightarrow 5\text{ V or } 5 \rightarrow 0\text{ V}, T_J = 25\text{ }^\circ\text{C},$ inductive load	—	100	—	ns
Turn-on Delay Time	$t_{d(ON)}$		—	550	—	ns
Rise Time	t_r		—	110	—	ns
Turn-off Delay Time	$t_{d(OFF)}$		—	600	—	ns
Fall Time	t_f		—	210	—	ns

SIM689xM Series

3.4.4 SIM6893M

Parameter	Symbol	Conditions	Min.	Typ.	Max.	Unit
Drain-to-Source Leakage Current	I_{DSS}	$V_{DS} = 600\text{ V}, V_{IN} = 0\text{ V}$	—	—	100	μA
Drain-to-Source On-resistance	$R_{DS(ON)}$	$I_D = 2.5\text{ A}, V_{IN} = 5\text{ V}$	—	0.45	0.60	Ω
Source-to-Drain Diode Forward Voltage	V_{SD}	$I_{SD} = 2.5\text{ A}, V_{IN} = 0\text{ V}$	—	1.0	1.6	V
High-side Switching						
Source-to-Drain Diode Reverse Recovery Time	t_{rr}	$V_{DC} = 300\text{ V}, I_D = 2.5\text{ A}, V_{IN} = 0 \rightarrow 5\text{ V or } 5 \rightarrow 0\text{ V}, T_J = 25\text{ }^\circ\text{C},$ inductive load	—	85	—	ns
Turn-on Delay Time	$t_{d(ON)}$		—	470	—	ns
Rise Time	t_r		—	40	—	ns
Turn-off Delay Time	$t_{d(OFF)}$		—	410	—	ns
Fall Time	t_f		—	30	—	ns
Low-side Switching						
Source-to-Drain Diode Reverse Recovery Time	t_{rr}	$V_{DC} = 300\text{ V}, I_D = 2.5\text{ A}, V_{IN} = 0 \rightarrow 5\text{ V or } 5 \rightarrow 0\text{ V}, T_J = 25\text{ }^\circ\text{C},$ inductive load	—	80	—	ns
Turn-on Delay Time	$t_{d(ON)}$		—	480	—	ns
Rise Time	t_r		—	40	—	ns
Turn-off Delay Time	$t_{d(OFF)}$		—	670	—	ns
Fall Time	t_f		—	30	—	ns

3.4.5 SIM6895M

Parameter	Symbol	Conditions	Min.	Typ.	Max.	Unit
Collector-to-Emitter Leakage Current	I_{CES}	$V_{CE} = 600\text{ V}, V_{IN} = 0\text{ V}$	—	—	1	mA
Collector-to-Emitter Saturation Voltage	$V_{CE(SAT)}$	$I_C = 5.0\text{ A}, V_{IN} = 5\text{ V}$	—	1.75	2.20	V
Diode Forward Voltage	V_F	$I_F = 5.0\text{ A}, V_{IN} = 0\text{ V}$	—	2.0	2.4	V
High-side Switching						
Diode Reverse Recovery Time	t_{rr}	$V_{DC} = 300\text{ V}, I_C = 5.0\text{ A}, V_{IN} = 0 \rightarrow 5\text{ V or } 5 \rightarrow 0\text{ V}, T_J = 25\text{ }^\circ\text{C},$ inductive load	—	100	—	ns
Turn-on Delay Time	$t_{d(ON)}$		—	760	—	ns
Rise Time	t_r		—	180	—	ns
Turn-off Delay Time	$t_{d(OFF)}$		—	500	—	ns
Fall Time	t_f		—	230	—	ns
Low-side Switching						
Diode Reverse Recovery Time	t_{rr}	$V_{DC} = 300\text{ V}, I_C = 5.0\text{ A}, V_{IN} = 0 \rightarrow 5\text{ V or } 5 \rightarrow 0\text{ V}, T_J = 25\text{ }^\circ\text{C},$ inductive load	—	100	—	ns
Turn-on Delay Time	$t_{d(ON)}$		—	840	—	ns
Rise Time	t_r		—	240	—	ns
Turn-off Delay Time	$t_{d(OFF)}$		—	510	—	ns
Fall Time	t_f		—	230	—	ns

SIM689xM Series**3.4.6 SIM6896M**

Parameter	Symbol	Conditions	Min.	Typ.	Max.	Unit
Collector-to-Emitter Leakage Current	I_{CES}	$V_{CE} = 600 \text{ V}, V_{IN} = 0 \text{ V}$	—	—	1	mA
Collector-to-Emitter Saturation Voltage	$V_{CE(SAT)}$	$I_C = 3.0 \text{ A}, V_{IN} = 5 \text{ V}$	—	1.85	2.30	V
Diode Forward Voltage	V_F	$I_F = 3.0 \text{ A}, V_{IN} = 0 \text{ V}$	—	2.0	2.4	V
High-side Switching						
Diode Reverse Recovery Time	t_{rr}	$V_{DC} = 300 \text{ V}, I_C = 3.0 \text{ A},$ $V_{IN} = 0 \rightarrow 5 \text{ V}$ or $5 \rightarrow 0 \text{ V},$ $T_J = 25 \text{ }^\circ\text{C},$ inductive load	—	125	—	ns
Turn-on Delay Time	$t_{d(ON)}$		—	630	—	ns
Rise Time	t_r		—	115	—	ns
Turn-off Delay Time	$t_{d(OFF)}$		—	470	—	ns
Fall Time	t_f		—	250	—	ns
Low-side Switching						
Diode Reverse Recovery Time	t_{rr}	$V_{DC} = 300 \text{ V}, I_C = 3.0 \text{ A},$ $V_{IN} = 0 \rightarrow 5 \text{ V}$ or $5 \rightarrow 0 \text{ V},$ $T_J = 25 \text{ }^\circ\text{C},$ inductive load	—	130	—	ns
Turn-on Delay Time	$t_{d(ON)}$		—	700	—	ns
Rise Time	t_r		—	140	—	ns
Turn-off Delay Time	$t_{d(OFF)}$		—	540	—	ns
Fall Time	t_f		—	200	—	ns

SIM689xM Series

4. Mechanical Characteristics

Parameter	Conditions	Min.	Typ.	Max.	Unit	Remarks
Heatsink Mounting Screw Torque	*	0.294	—	0.441	N·m	
Flatness of Heatsink Attachment Area	See Figure 4-1.	0	—	100	μm	
Package Weight		—	5.2	—	g	

* Requires using a metric screw of M2.5 and a plain washer of 6.0 mm (ϕ). For more on screw tightening, see Section 13.2.

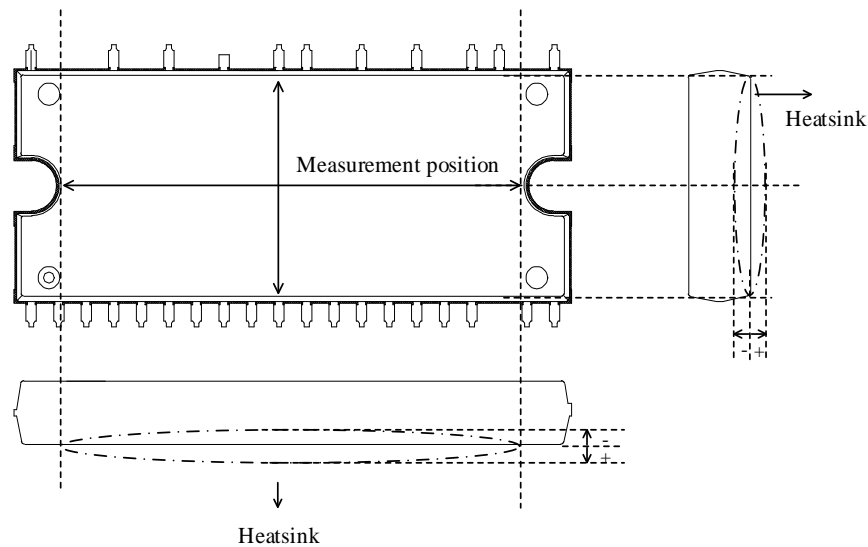

Figure 4-1. Flatness Measurement Position

5. Insulation Distance

Parameter	Conditions	Min.	Typ.	Max.	Unit	Remarks
Clearance	Between heatsink* and leads. See Figure 5-1.	1.5	—	2.1	mm	
Creepage		1.7	—	—	mm	

* Refers to when a heatsink to be mounted is flat. If your application requires a clearance exceeding the maximum distance given above, use an alternative (e.g., a convex heatsink) that will meet the target requirement.

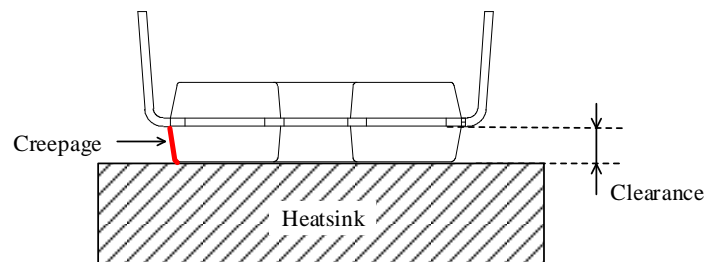

Figure 5-1. Insulation Distance Definitions

SIM689xM Series

6. Truth Table

Table 6-1 is a truth table that provides the logic level definitions of operation modes.

In the case where HINx and LINx pin signals in each phase are high at the same time, both the high- and low-side transistors become on (simultaneous on-state). Therefore, HINx and LINx signals, the input signals for the HINx and LINx pins, require dead time setting so that such a simultaneous on-state event can be avoided.

After the IC recovers from a UVLO_VCC condition, the high- and low-side transistors resume switching, according to the input logic levels of the HINx and LINx signals (level-triggered).

After the IC recovers from a UVLO_VB condition, the high-side transistors resume switching at the next rising edge of an HINx signal (edge-triggered).

Table 6-1. Truth Table for Operation Modes

Mode	HINx	LINx	High-side Transistor	Low-side Transistor
Normal Operation	L	L	OFF	OFF
	H	L	ON	OFF
	L	H	OFF	ON
	H	H	ON	ON
Undervoltage Lockout for High-side Power Supply (UVLO_VB)	L	L	OFF	OFF
	H	L	OFF	OFF
	L	H	OFF	ON
	H	H	OFF	ON
Undervoltage Lockout for Low-side Power Supply (UVLO_VCC)	L	L	OFF	OFF
	H	L	OFF	OFF
	L	H	OFF	OFF
	H	H	OFF	OFF
Overcurrent Protection (OCP)	L	L	OFF	OFF
	H	L	ON	OFF
	L	H	OFF	OFF
	H	H	ON	OFF
Thermal Shutdown (TSD)	L	L	OFF	OFF
	H	L	ON	OFF
	L	H	OFF	OFF
	H	H	ON	OFF

SIM689xM Series

8. Pin Configuration Definitions

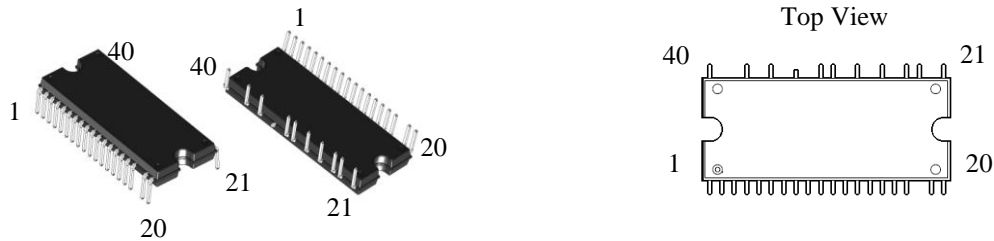

Pin Number	Pin Name	Description
1	LS3A	W-phase low-side power MOSFET source or IGBT emitter
2	LS2	V-phase low-side power MOSFET source or IGBT emitter
3	OCP	Input for overcurrent protection
4	FO	Fault signal output
5	VCC2	Low-side logic supply voltage input
6	COM2	Low-side logic ground
7	LIN1	Logic input for U-phase low-side gate driver
8	LIN2	Logic input for V-phase low-side gate driver
9	LIN3	Logic input for W-phase low-side gate driver
10	VT	Temperature sensing voltage output
11	LS1	U-phase low-side power MOSFET source or IGBT emitter
12	NC	(No connection)
13	HIN1	Logic input for U-phase high-side gate driver
14	HIN2	Logic input for V-phase high-side gate driver
15	HIN3	Logic input for W-phase high-side gate driver
16	COM1	High-side logic ground
17	VCC1	High-side logic supply voltage input
18	—	(Pin removed)
19	V	V-phase bootstrap capacitor connection
20	VB2	V-phase high-side floating supply voltage input
21	VB1A	U-phase high-side floating supply voltage input
22	—	(Pin removed)
23	VB3	W-phase high-side floating supply voltage input
24	W1	W-phase output (connected to W2 externally)
25	—	(Pin removed)
26	V1	V-phase output (connected to V2 externally)
27	—	(Pin removed)
28	VBB	Positive DC bus supply voltage (+)
29	—	(Pin removed)
30	VB1B	U-phase high-side floating supply voltage input
31	U	U-phase output
32	—	(Pin removed)
33	LS2	(Pin trimmed) V-phase low-side power MOSFET source or IGBT emitter
34	—	(Pin removed)
35	V2	V-phase output (connected to V1 externally)
36	—	(Pin removed)
37	W2	W-phase output (connected to W1 externally)
38	—	(Pin removed)
39	—	(Pin removed)
40	LS3B	W-phase low-side power MOSFET source or IGBT emitter

SIM689xM Series

9. Typical Applications

CR filters and Zener diodes should be added to your application as needed. This is to protect each pin against surge voltages causing malfunctions, and to avoid the IC being used under the conditions exceeding the absolute maximum ratings where critical damage is inevitable. Then, check all the pins thoroughly under actual operating conditions to ensure that your application works flawlessly.

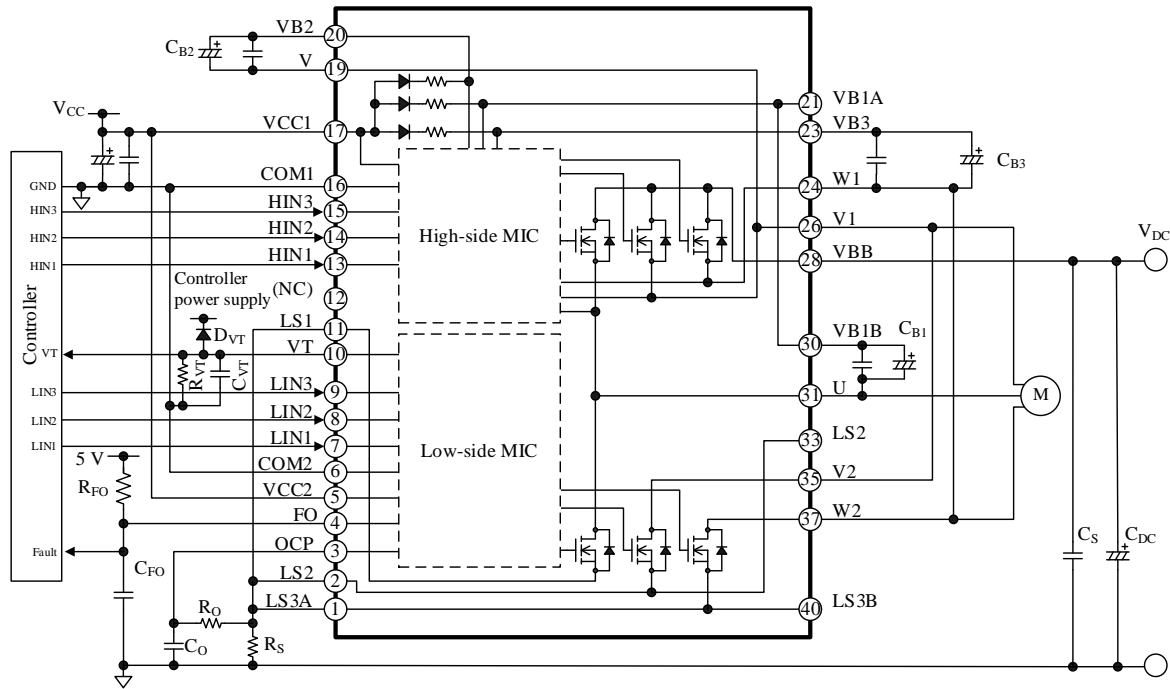

Figure 9-1. SIM6891MD Typical Application Using a Single Shunt Resistor

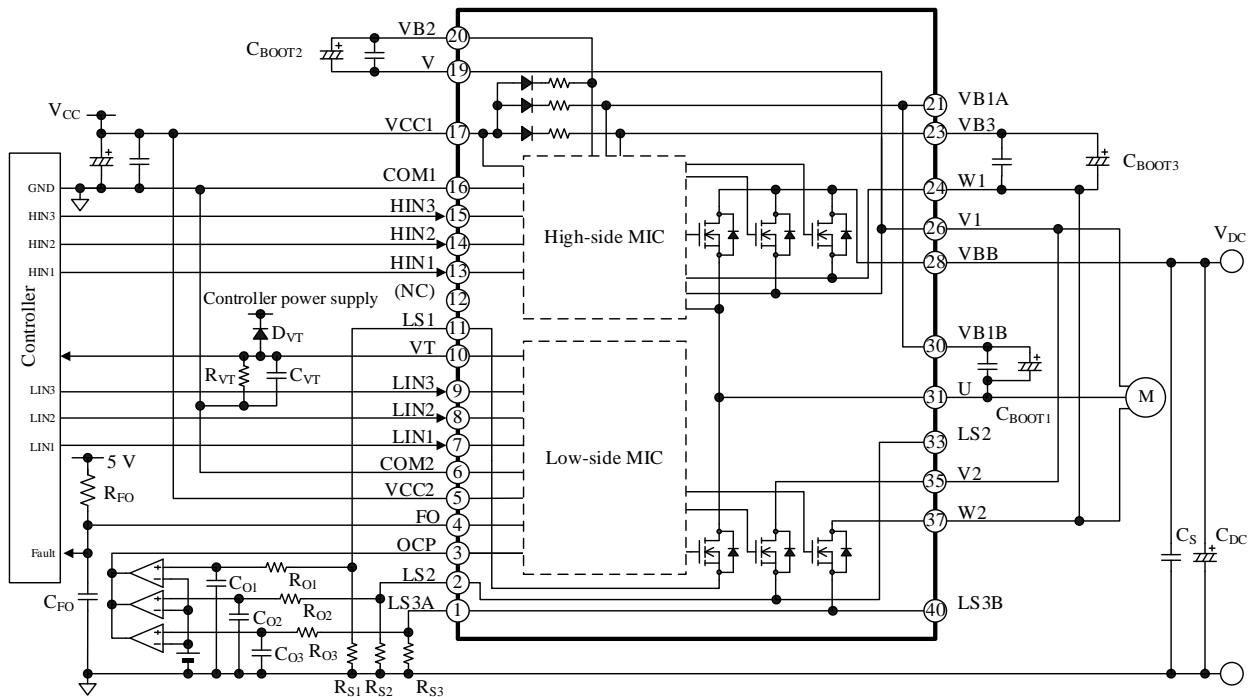
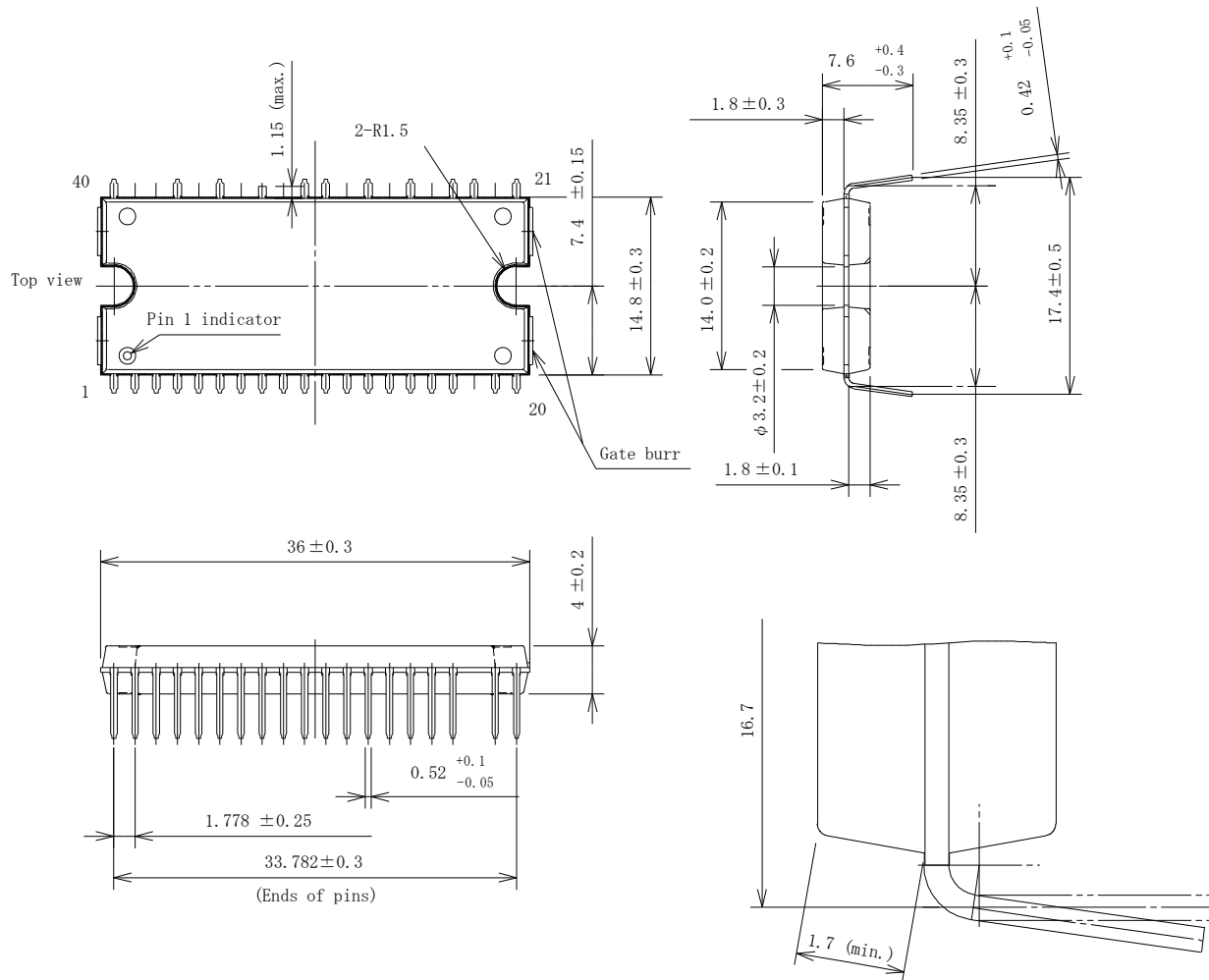

Figure 9-2. SIM6891MD Typical Application Using Three Shunt Resistors

SIM689xM Series

10. Physical Dimensions

• DIP40 Package



NOTES:

- Dimensions in millimeters
- Pb-free (RoHS compliant)
- The leads illustrated above are for reference only, and may not be actual states of being bent.
- Maximum gate burr height is 0.3 mm.

SIM689xM Series

• Reference Through Hole Size and Layout

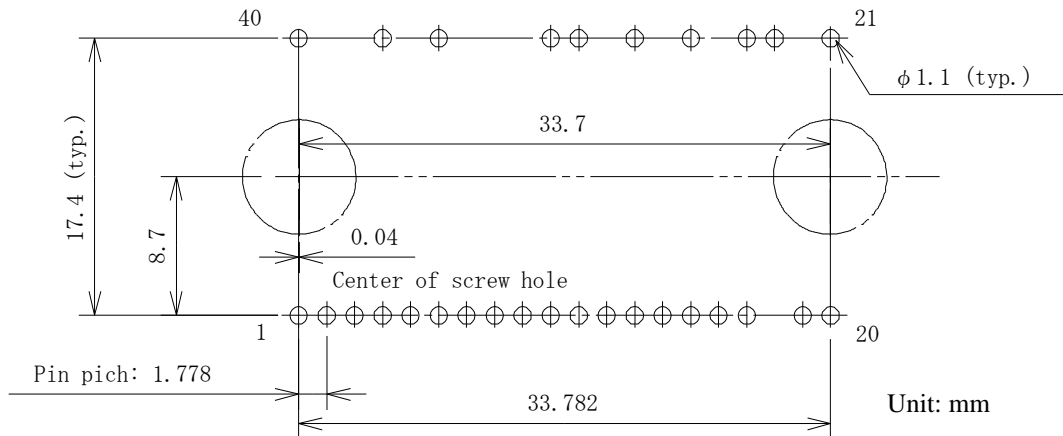

SIM689xM Series

11. Marking Diagram

- SIM6892M, 93M, 95M, 96M

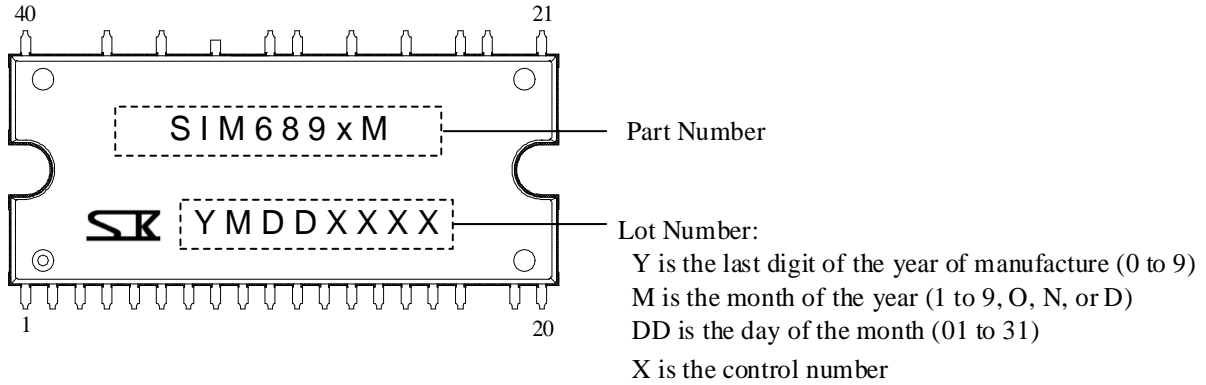

- SIM6891MD

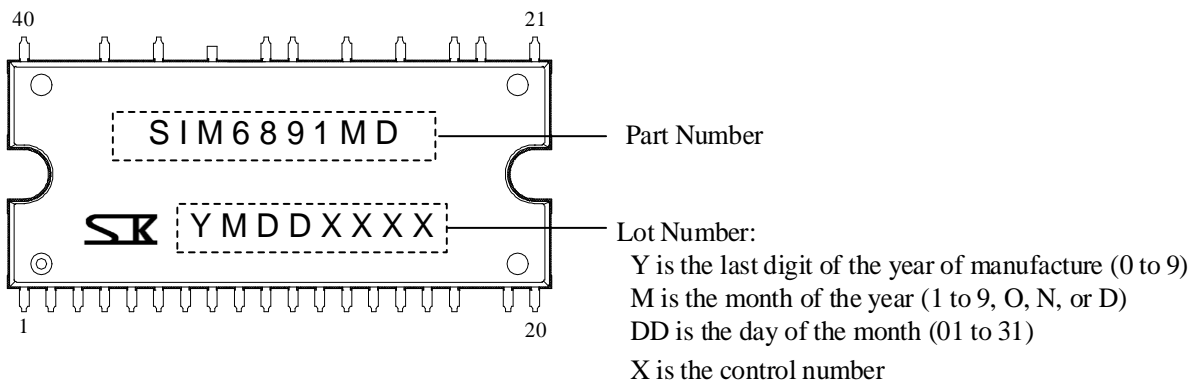

- SIM6891MDN

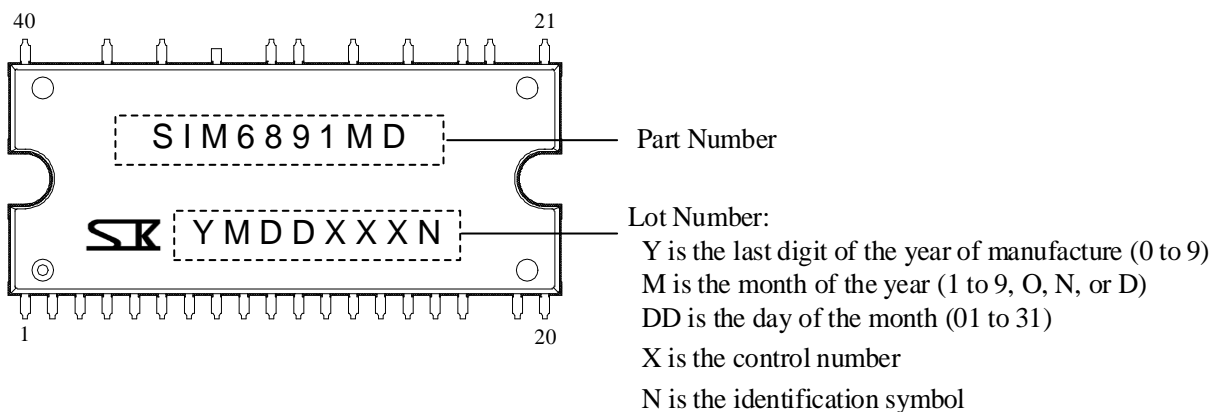

SIM689xM Series

12. Functional Descriptions

Unless specifically noted, this section uses the following definitions:

- All the characteristic values given in this section are typical values.
- All the circuit diagrams listed in this section represent the type of IC that incorporates power MOSFETs. All the functional descriptions in this section are also applicable to the type of IC that incorporates IGBTs.
- For pin and peripheral component descriptions, this section employs a notation system that denotes a pin name with the arbitrary letter “x”, depending on context. Thus, “the VCCx pin” is used when referring to either or both of the VCC1 and VCC2 pins.
- The COM1 pin is always connected to the COM2 pin.

12.1 Turning On and Off the IC

The procedures listed below provide recommended startup and shutdown sequences. To turn on the IC properly, do not apply any voltage on the VBB, HINx, and LINx pins until the VCCx pin voltage has reached a stable state ($V_{CC(ON)} \geq 12.5$ V).

It is required to fully charge bootstrap capacitors, C_{Bx} , at startup (see Section 12.2.2).

To turn off the IC, set the HINx and LINx pins to logic low (or “L”), and then decrease the VCCx pin voltage.

12.2 Pin Descriptions

12.2.1 U, V, V1, V2, W1, and W2

The U, V1, V2, W1, and W2 pins are the outputs of the three phases, and serve as the connection terminals to the 3-phase motor. The V pin must be connected to a bootstrap capacitor of the V-phase. Do not connect the 3-phase motor to the V pin. The V1 and W1 pins must be connected to the V2 and W2 pins on a PCB, respectively.

The U, V (V1) and W1 pins are the grounds for the VB1A (VB1B), VB2, and VB3 pins. The U, V, and W1 pins are connected to the negative nodes of bootstrap capacitors, C_{Bx} . The V pin is internally connected to the V1 pin.

Since high voltages are applied to these output pins (U, V1, V2, W1, and W2), it is required to take measures for insulating as follows:

- Keep enough distance between the output pins and low-voltage traces.
- Coat the output pins with insulating resin.

12.2.2 VB1A, VB1B, VB2, and VB3

These pins are connected to bootstrap capacitors for the high-side floating supply.

In actual applications, use either of the VB1A or VB1B pin because they are internally connected.

Voltages across the VBx and these output pins should be maintained within the recommended range (i.e., the Logic Supply Voltage, V_{BS}) given in Section 2.

A bootstrap capacitor, C_{Bx} , should be connected in each of the traces between the VB1A (VB1B) and U pins, the VB2 and V pins, the VB3 and W1 pins.

For proper startup, turn on the low-side transistor first, then fully charge the bootstrap capacitor, C_{Bx} .

For the capacitance of the bootstrap capacitors, C_{Bx} , choose the values that satisfy Equations (1) and (2). Note that capacitance tolerance and DC bias characteristics must be taken into account when you choose appropriate values for C_{Bx} .

$$C_{Bx}(\mu\text{F}) > 800 \times t_{L(OFF)} \quad (1)$$

$$1 \mu\text{F} \leq C_{Bx} \leq 220 \mu\text{F} \quad (2)$$

In Equation (1), let $t_{L(OFF)}$ be the maximum off-time of the low-side transistor (i.e., the non-charging time of C_{Bx}), measured in seconds.

Even while the high-side transistor is not on, voltage across the bootstrap capacitor keeps decreasing due to power dissipation in the IC. When the VBx pin voltage decreases to $V_{BS(OFF)}$ or less, the high-side undervoltage lockout (UVLO_VB) starts operating (see Section 12.4.2.1). Therefore, actual board checking should be done thoroughly to validate that voltage across the VBx pin maintains over 11.0 V ($V_{BS} > V_{BS(OFF)}$) during a low-frequency operation such as a startup period.

As Figure 12-1 shows, a bootstrap diode, D_{Bx} , and a current-limiting resistor, R_{Bx} , are internally placed in series between the VCC1 and VBx pins.

Time constant for the charging time of C_{Bx} , τ , can be computed by Equation (3):

$$\tau = C_{Bx} \times R_{Bx} \quad (3)$$

where C_{Bx} is the optimized capacitance of the bootstrap capacitor, and R_{Bx} is the resistance of the current-limiting resistor ($60 \Omega \pm 25\%$).

SIM689xM Series

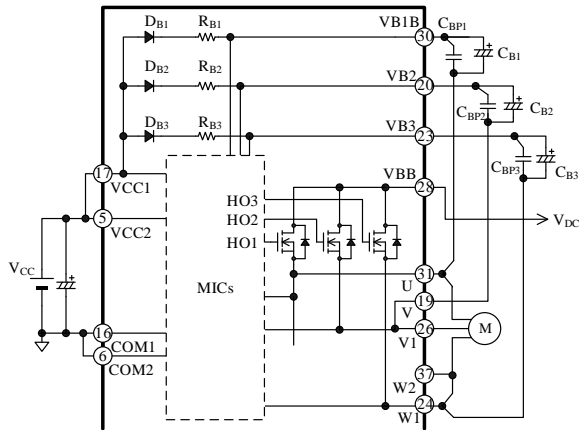

Figure 12-1. Bootstrap Circuit

Figure 12-2 shows an internal level-shifting circuit. A high-side output signal, HOx, is generated according to an input signal on the HINx pin. When an input signal on the HINx pin transits from low to high (rising edge), a “Set” signal is generated. When the HINx input signal transits from high to low (falling edge), a “Reset” signal is generated. These two signals are then transmitted to the high-side by the level-shifting circuit and are input to the SR flip-flop circuit. Finally, the SR flip-flop circuit feeds an output signal, Q (i.e., HOx).

Figure 12-3 is a timing diagram describing how noise or other detrimental effects will improperly influence the level-shifting process. When a noise-induced rapid voltage drop between the VBx and output pins (U, V, or W1; hereafter “VBx–HSx”) occurs after the Set signal generation, the next Reset signal cannot be sent to the SR flip-flop circuit. And the state of an HOx signal stays logic high (or “H”) because the SR flip-flop does not respond. With the HOx state being held high (i.e., the high-side transistor is in an on-state), the next LINx signal turns on the low-side transistor and causes a simultaneously-on condition, which may result in critical damage to the IC. To protect the VBx pin against such a noise effect, add a bootstrap capacitor, CBx, in each phase. CBx must be placed near the IC and be connected between the VBx and HSx pins with a minimum length of trace. To use an electrolytic capacitor, add a 0.01 μF to 0.1 μF bypass capacitor, CBPx, in parallel near these pins used for the same phase.

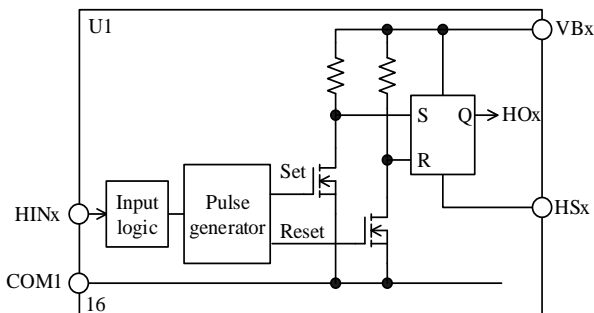

Figure 12-2. Internal Level-shifting Circuit

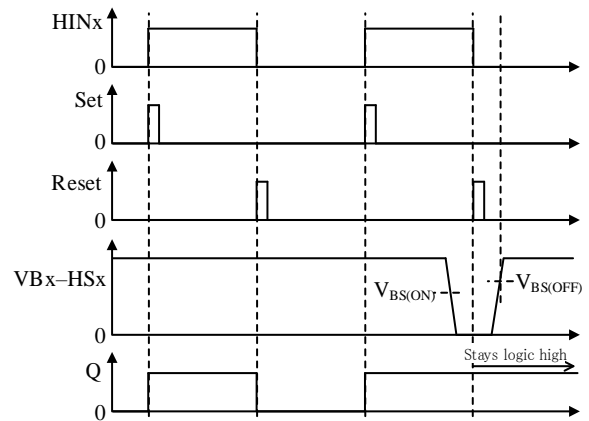

Figure 12-3. Waveforms at VBx–HSx Voltage Drop

12.2.3 VCC1 and VCC2

These are the logic supply pins for the built-in control MICs. The VCC1 and VCC2 pins must be externally connected on a PCB because they are not internally connected. To prevent malfunction induced by supply ripples or other factors, put a 0.01 μF to 0.1 μF ceramic capacitor, Cp, near these pins. To prevent damage caused by surge voltages, put an 18 V to 20 V Zener diode, DZ, between the VCCx and COMx pins.

Voltages to be applied between the VCCx and COMx pins should be regulated within the recommended operational range of VCC, given in Section 2.

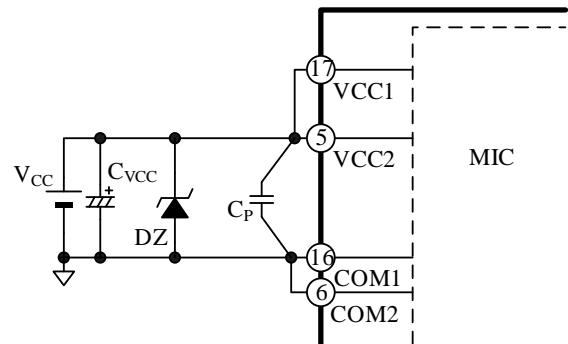

Figure 12-4. VCCx Pin Peripheral Circuit

SIM689xM Series

12.2.4 COM1 and COM2

These are the logic ground pins for the built-in control MICs. The COM1 and COM2 pins should be connected externally on a PCB because they are not internally connected. Varying electric potential of the logic ground can be a cause of improper operations. Therefore, connect the logic ground as close and short as possible to a shunt resistor, R_{Sx} , at a single-point ground (or star ground) which is separated from the power ground (see Figure 12-5).

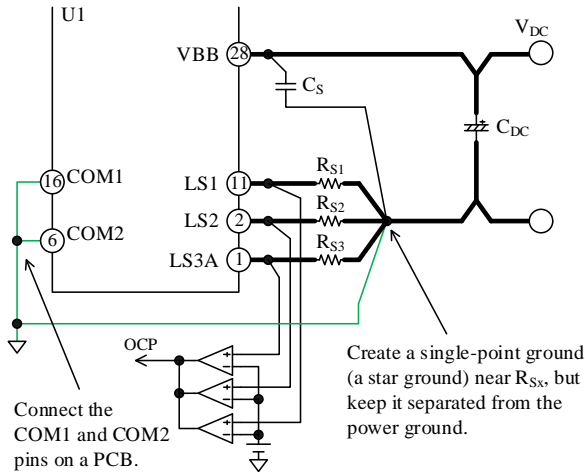

Figure 12-5. Connections to Logic Ground

12.2.5 HIN1, HIN2, and HIN3; LIN1, LIN2, and LIN3

These are the input pins of the internal motor drivers for each phase. The HIN_x pin acts as a high-side controller; the LIN_x pin acts as a low-side controller.

Figure 12-6 shows an internal circuit diagram of the HIN_x or LIN_x pin. This is a CMOS Schmitt trigger circuit with a built-in 20 k Ω pull-down resistor, and its input logic is active high.

Input signals applied across the HIN_x–COM_x and the LIN_x–COM_x pins in each phase should be set within the ranges provided in Table 12-1, below. **Note that dead time setting must be done for HIN_x and LIN_x signals** because the IC does not have a dead time generator.

The higher PWM carrier frequency rises, the more switching loss increases. Hence, the PWM carrier frequency must be set so that operational case temperatures and junction temperatures have sufficient margins against the absolute maximum ranges, specified in Section 1.

If the signals from the microcontroller become unstable, the IC may result in malfunctions. To avoid such malfunctions, set the microcontroller output line not to have high-impedance outputs. Also, if the traces from the microcontroller to the HIN_x or LIN_x pin (or both) are too long, the traces may be interfered by noise.

Therefore, it is recommended to add an additional filter or a pull-down resistor near the HIN_x or LIN_x pin as needed (see Figure 12-7).

Here are filter circuit constants for reference:

- R_{IN1x} : 33 Ω to 500 Ω
- R_{IN2x} : 5 k Ω to 10 k Ω
- C_{INx} : 100 pF to 200 pF

Care should be taken in adding R_{IN1x} and R_{IN2x} to the traces. When they are connected to each other, the input voltage of the HIN_x and LIN_x pins becomes slightly lower than the output voltage of the microcontroller.

Table 12-1. Input Signals for HIN_x and LIN_x Pins

Parameter	High Level Signal	Low Level Signal
Input Voltage	$3\text{ V} < V_{IN} < 5.5\text{ V}$	$0\text{ V} < V_{IN} < 0.5\text{ V}$
Input Pulse Width	$\geq 0.5\text{ }\mu\text{s}$	$\geq 0.5\text{ }\mu\text{s}$
PWM Carrier Frequency	$\leq 20\text{ kHz}$	
Dead Time	$\geq 1.5\text{ }\mu\text{s}$	

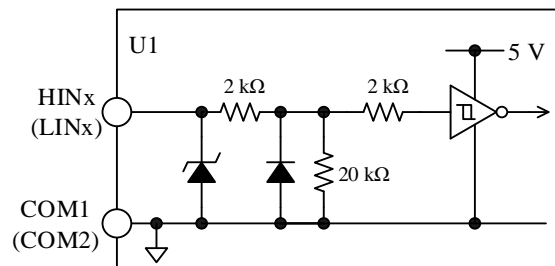

Figure 12-6. Internal Circuit Diagram of HIN_x or LIN_x Pin

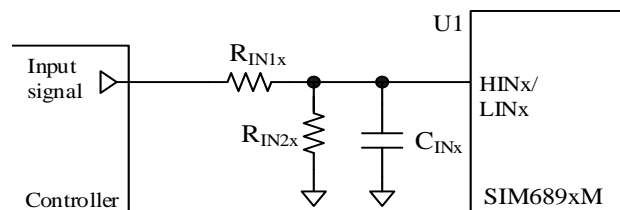

Figure 12-7. Filter Circuit for HIN_x or LIN_x Pin

SIM689xM Series

12.2.6 VBB

This is the input pin for the main supply voltage, i.e., the positive DC bus. All of the power MOSFET drains (IGBT collectors) of the high-side are connected to this pin. Voltages between the VBB and COMx pins should be set within the recommended range of the main supply voltage, V_{DC} , given in Section 2.

To suppress surge voltages, put a $0.01 \mu\text{F}$ to $0.1 \mu\text{F}$ bypass capacitor, C_S , near the VBB pin and an electrolytic capacitor, C_{DC} , with a minimum length of PCB trace to the VBB pin.

12.2.7 LS1, LS2, LS3A, and LS3B

These are the source (emitter) pins of the low-side power MOSFETs (IGBTs). For current detection, the LS1, LS2, and LS3A (LS3B) pins should be externally connected to shunt resistors, R_{Sx} . In actual applications, use either of the LS3A or LS3B pin because they are internally connected.

When connecting a shunt resistor, use a resistor with low inductance, and place it as near as possible to the IC with a minimum length of trace to the LSx and COMx pins. Otherwise, malfunction may occur because a longer circuit trace increases its inductance and thus increases its susceptibility to improper operations. In applications where long PCB traces are required, add a fast recovery diode, D_{RSx} , between the LSx and COMx pins in order to prevent the IC from malfunctioning.

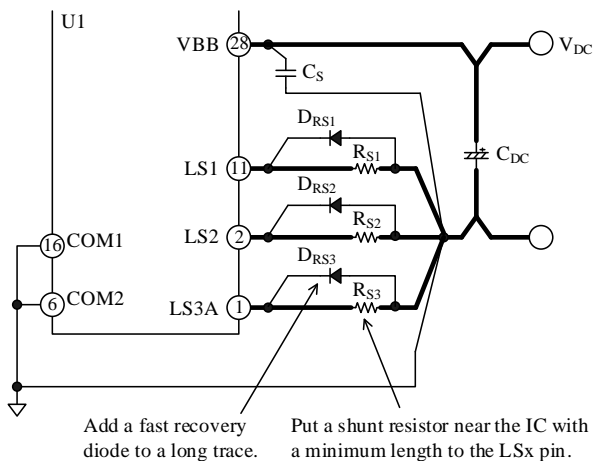

Figure 12-8. Connections to LSx Pin

12.2.8 OCP

The OCP pin serves as the input for the overcurrent protections which monitor the currents going through the output transistors. For more details on the overcurrent protection (OCP), see Section 12.4.3.

12.2.9 FO

The FO pin operates as the fault signal output. For more details on this function, see Section 12.4.1. Figure 12-9 illustrates an internal circuit diagram of the FO pin and its peripheral circuit. Because of its open-collector nature, the FO pin should be tied by a pull-up resistor, R_{FO} , to the external power supply. The external power supply voltage (i.e., the FO Pin Pull-up Voltage, V_{FO}) should range from 3.0 V to 5.5 V. When the pull-up resistor, R_{FO} , has a too small resistance, the FO pin voltage at fault signal output becomes high due to the saturation voltage drop of a built-in transistor, Q_{FO} . Therefore, it is recommended to use a $3.3 \text{ k}\Omega$ to $10 \text{ k}\Omega$ pull-up resistor. To suppress noise, add a filter capacitor, C_{FO} , near the IC with minimizing a trace length between the FO and COMx pins.

For avoiding repeated OCP activation, the external microcontroller must shut off any input signals to the IC within an OCP hold time, $t_p = 5 \text{ ms}$ (min.), after the internal transistor (Q_{FO}) turn-on. (For more details, see Section 12.4.3) Our recommendation is to use a $0.001 \mu\text{F}$ to $0.01 \mu\text{F}$ filter capacitor.

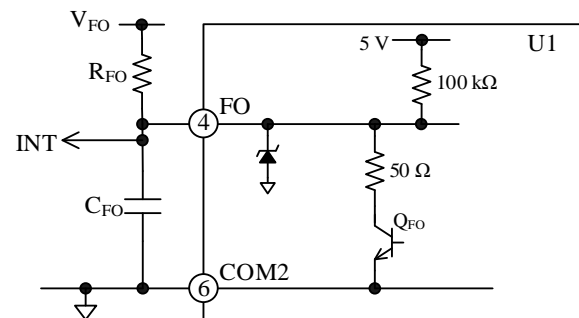

Figure 12-9. Internal Circuit Diagram of FO Pin and Its Peripheral Circuit

12.2.10 VT

This pin outputs temperature sensing voltages. The external microcontroller can monitor the junction temperature of the internal control stage, not of the output transistors, with the VT pin. Section 12.3 explains the configuration of the VT pin and its peripheral circuit and the temperature sensing function.

12.3 Temperature Sensing Function

The microcontroller can monitor the junction temperature of the internal control stage, through temperature sensing voltages that the VT pin outputs. The IC must be set to stop its operation as it detects an abnormal heating state with temperature sensing voltages. A typical example is turning off input signals from the microcontroller. Figure 12-11 shows a relation between the VT pin voltage and temperature. Table 12-2

SIM689xM Series

and Table 12-3 provide the details of variations found in Figure 12-11.

Temperature sensing voltages may exceed 3.0 V, causing permanent damage to the IC in the worst case. To protect the parts connected to the VT pin such as the microcontroller, add a clamp diode, D_{VT} , between the microcontroller power supply and the VT pin (see Figure 12-10).

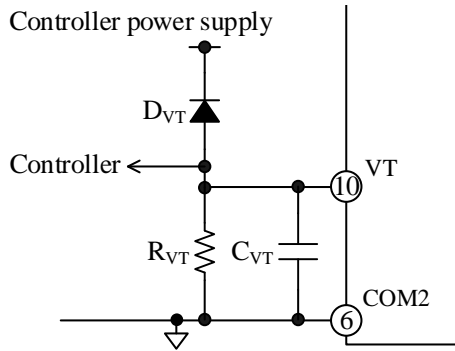

Figure 12-10. VT Pin Peripheral Circuit

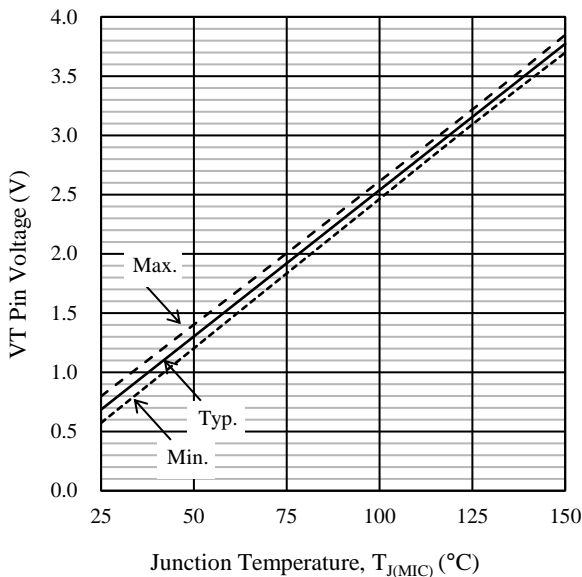

Figure 12-11. VT Pin Voltage vs. Internal Control Stage Junction Temperature, $T_{J(MIC)}$ (Design Value)

Table 12-2. $T_{J(MIC)}$ Variation on VT Pin Voltage (Design Value)

VT Pin Voltage (V)	$T_{J(MIC)}$ (°C)
1.30	50 ± 4
3.15	125 ± 3

Table 12-3. VT Pin Voltage Variation on $T_{J(MIC)}$ (Design Value)

$T_{J(MIC)}$ (°C)	VT Pin Voltage (V)
50	1.30 ± 0.10
125	3.15 ± 0.07

12.4 Protection Functions

This section describes the various protection circuits provided in the SIM689xM series. The protection circuits include the undervoltage lockout for power supplies (UVLO), the overcurrent protection (OCP), and the thermal shutdown (TSD). In case one or more of these protection circuits are activated, the FO pin outputs a fault signal; as a result, the external microcontroller can stop the operations of the three phases by receiving the fault signal. In the following functional descriptions, “HOx” denotes a gate input signal on the high-side transistor, whereas “LOx” denotes a gate input signal on the low-side transistor. “VBx-HSx” refers to the voltages between the VBx pin and output pins (U, V, and W1).

12.4.1 Fault Signal Output

In case one or more of the following protections are actuated, an internal transistor, Q_{FO} , turns on, then the FO pin becomes logic low (≤ 0.5 V).

- 1) Low-side undervoltage lockout (UVLO_VCC)
- 2) Overcurrent protection (OCP)
- 3) Thermal shutdown (TSD)

While the FO pin is in the low state, all the low-side transistors turn off. In normal operation, the FO pin outputs a high signal of about 5 V. Motor operations must be controlled by the external microcontroller so that it can immediately stop the motor when fault signals are detected. To prevent the IC from having permanent damage at OCP activation, be sure to set the motor operation to stop within $t_P = 10.0$ ms (typ.). t_P is the fault signal output time of the FO pin, fixed by a built-in feature of the IC itself (see Section 12.4.3). To resume the motor operation thereafter, set the motor to be resumed after a lapse of ≥ 2 seconds.

12.4.2 Undervoltage Lockout for Power Supply (UVLO)

In case the gate-driving voltages of the output transistors decrease, their steady-state power dissipations increase. This overheating condition may cause permanent damage to the IC in the worst case. To prevent this event, the SIM689xM series has the undervoltage lockout (UVLO) circuits for both of the

SIM689xM Series

high- and low-side power supplies.

12.4.2.1. Undervoltage Lockout for High-side Power Supply (UVLO_VB)

Figure 12-12 shows operational waveforms of the undervoltage lockout for high-side power supply (i.e., UVLO_VB).

When the voltage between the VBx and output pins (VBx- HS_x) decreases to the High-side Logic Operation Stop Voltage ($V_{BS(OFF)} = 10.0\text{ V}$) or less, the UVLO_VB circuit in the corresponding phase gets activated and sets an HOx signal to logic low. When the voltage between the VBx and HSx pins increases to the High-side Logic Operation Start Voltage ($V_{BS(ON)} = 10.5\text{ V}$) or more, the IC releases the UVLO_VB operation. Then, the HOx signal becomes logic high at the rising edge of the first input command after the UVLO_VB release. Any fault signals are not output from the FO pin during the UVLO_VB operation. In addition, the VBx pin has an internal UVLO_VB filter of about $3\ \mu\text{s}$, in order to prevent noise-induced malfunctions.

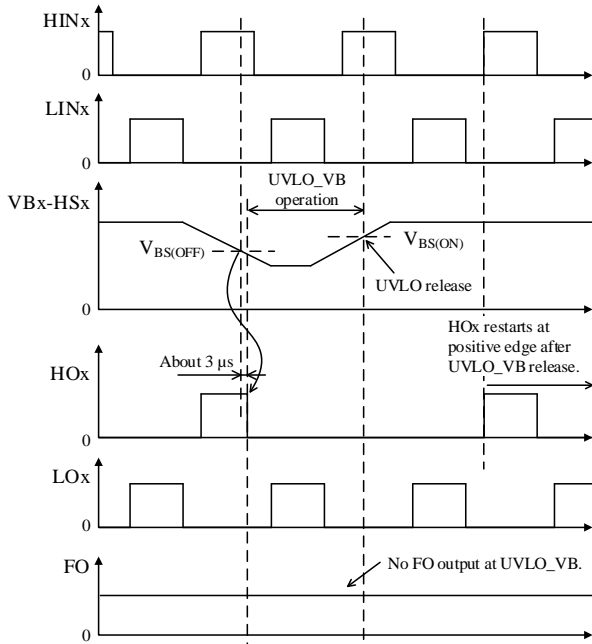

Figure 12-12. UVLO_VB Operational Waveforms

12.4.2.2. Undervoltage Lockout for Low-side Power Supply (UVLO_VCC)

Figure 12-13 shows operational waveforms of the undervoltage lockout for low-side power supply (i.e., UVLO_VCC). When the VCC2 pin voltage decreases to the Low-side Logic Operation Stop Voltage ($V_{CC(OFF)} = 11.0\text{ V}$) or less, the UVLO_VCC circuit in

the corresponding phase gets activated and sets both of HOx and LOx signals to logic low. When the VCC2 pin voltage increases to the Low-side Logic Operation Start Voltage ($V_{CC(ON)} = 11.5\text{ V}$) or more, the IC releases the UVLO_VCC operation. The IC then resumes transmitting HOx and LOx signals according to input commands on the HINx and LINx pins, respectively. During the UVLO_VCC operation, the FO pin becomes logic low and sends fault signals.

In addition, the VCC2 pin has an internal UVLO_VCC filter of about $3\ \mu\text{s}$, in order to prevent noise-induced malfunctions.

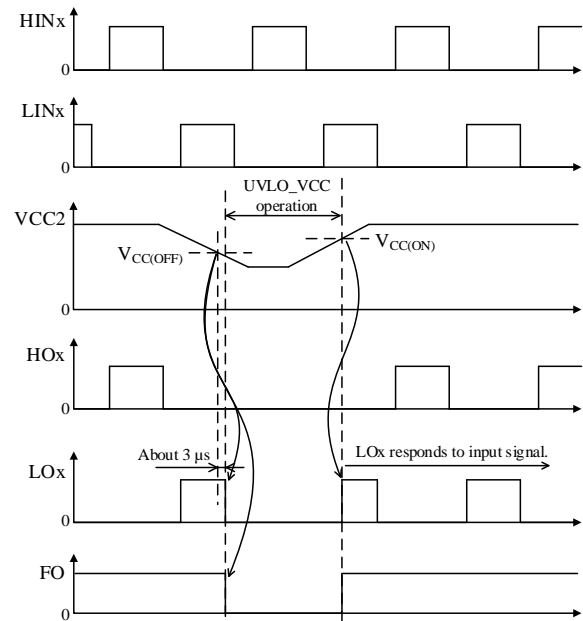

Figure 12-13. UVLO_VCC Operational Waveforms

12.4.3 Overcurrent Protection (OCP)

The overcurrent protection (OCP) is a protection against large inrush currents (i.e., high di/dt). Figure 12-14 is an internal circuit diagram describing the OCP pin and its peripheral circuit. The OCP pin detects overcurrents with voltage across external shunt resistors, R_{Sx} . Because the OCP pin is internally pulled down, the OCP pin voltage increases proportionally to a rise in the current running through the shunt resistor, R_{Sx} .

SIM689xM Series

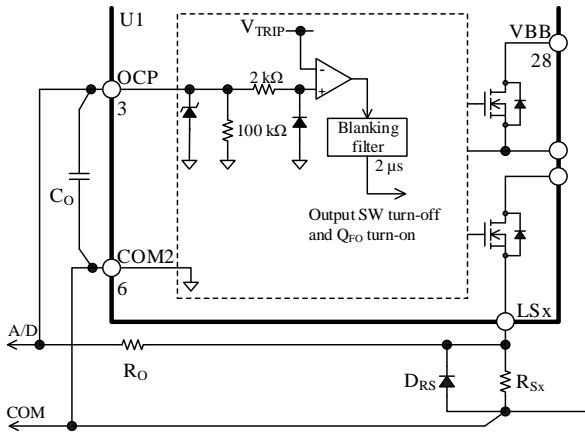

Figure 12-14. Internal Circuit Diagram of OCP Pin and Its Peripheral Circuit

Figure 12-15 is a timing chart that represents operation waveforms during OCP operation. When the OCP pin voltage increases to the OCP Threshold Voltage ($V_{TRIP} = 0.50$ V) or more, and remains in this condition for a period of the OCP Blanking Time (see Section 3.1) or longer, the OCP circuit is activated. The enabled OCP circuit shuts off the low-side transistors and puts the FO pin into a low state.

Then, output current decreases as a result of the output transistor turn-offs. Even if the OCP pin voltage falls below V_{TRIP} , the IC holds the FO pin in the low state for a fixed OCP hold time, $t_p = 10.0$ ms (typ.). Then, the output transistors operate according to input signals.

The OCP is used for detecting abnormal conditions, such as an output transistor shorted. In case short-circuit conditions occur repeatedly, the output transistors can be destroyed. For this reason, motor operations must be controlled by the external microcontroller so that it can immediately stop the motor when fault signals are detected.

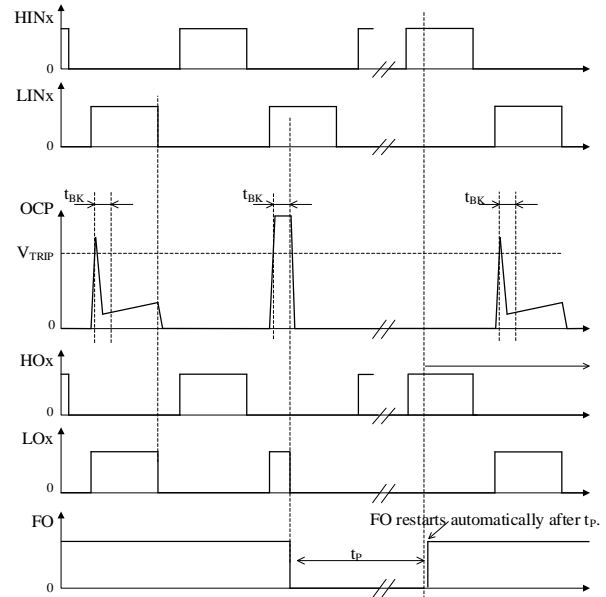

Figure 12-15. OCP Operational Waveforms

For proper shunt resistor setting, your application must meet the following:

- Use the shunt resistor that has a recommended resistance, R_{Sx} (see Section 2).
- Set the OCP pin input voltage to vary within the rated OCP pin voltages, V_{OCP} (see Section 1).
- Keep the current through the output transistors below the rated output current (pulse), I_{OP} (see Section 1).

It is required to use a resistor with low internal inductance because high-frequency switching current will flow through the shunt resistors, R_{Sx} . In addition, choose a resistor with allowable power dissipation according to your application.

When you connect a CR filter (i.e., a pair of a filter resistor, R_{Sx} , and a filter capacitor, C_O) to the OCP pin, care should be taken in setting the time constants of R_O and C_O . The larger the time constant, the longer the time that the OCP pin voltage rises to V_{TRIP} . And this may cause permanent damage to the transistors. Consequently, a propagation delay of the IC must be taken into account when you determine the time constants. For R_O and C_O , their time constants must be set to ≤ 0.2 μ s.

Note that overcurrents are undetectable when one or more of the U, V/V1/V2, and W1/W2 pins or their traces are shorted to ground (ground fault). In case any of these pins falls into a state of ground fault, the output transistors may be destroyed.

12.4.4 Thermal Shutdown (TSD)

The SIM689xM series incorporates the thermal shutdown (TSD) circuit. Figure 12-16 shows TSD

SIM689xM Series

operational waveforms. In case of overheating (e.g., increased power dissipation due to overload, or elevated ambient temperature at the device), the IC shuts down the low-side output transistors.

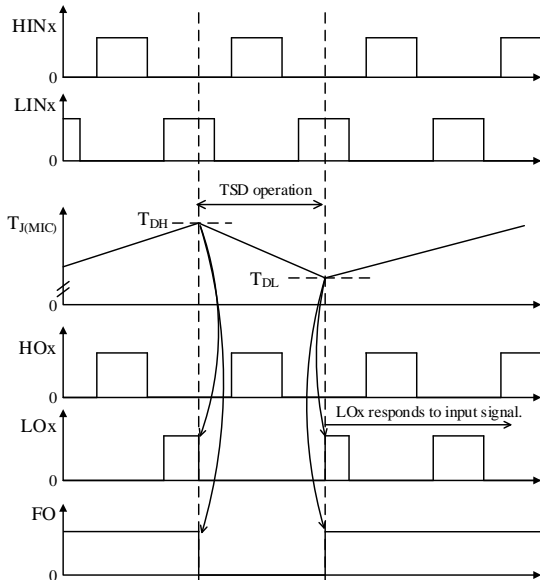

Figure 12-16. TSD Operational Waveforms

The TSD circuit in the low-side MIC monitors temperatures (see Section 7). When the temperature of the low-side MIC exceeds the TSD Operating Temperature ($T_{DH} = 150\text{ }^{\circ}\text{C}$), the TSD circuit is activated. When the temperature of the low-side MIC decreases to the TSD Releasing Temperature ($T_{DL} = 120\text{ }^{\circ}\text{C}$) or less, the shutdown condition is released. The output transistors then resume operating according to input signals. During the TSD operation, the FO pin becomes logic low and transmits fault signals. Note that junction temperatures of the output transistors themselves are not monitored; therefore, do not use the TSD function as an overtemperature prevention for the output transistors.

13. Design Notes

13.1 PCB Pattern Layout

Figure 13-1 shows a schematic diagram of a motor drive circuit. The circuit consists of current paths having high frequencies and high voltages, which also bring about negative influences on IC operation, noise interference, and power dissipation. Therefore, PCB trace layouts and component placements play an important role in circuit designing.

Current loops, which have high frequencies and high voltages, should be as small and wide as possible, in order to maintain a low-impedance state. In addition,

ground traces should be as wide and short as possible so that radiated EMI levels can be reduced.

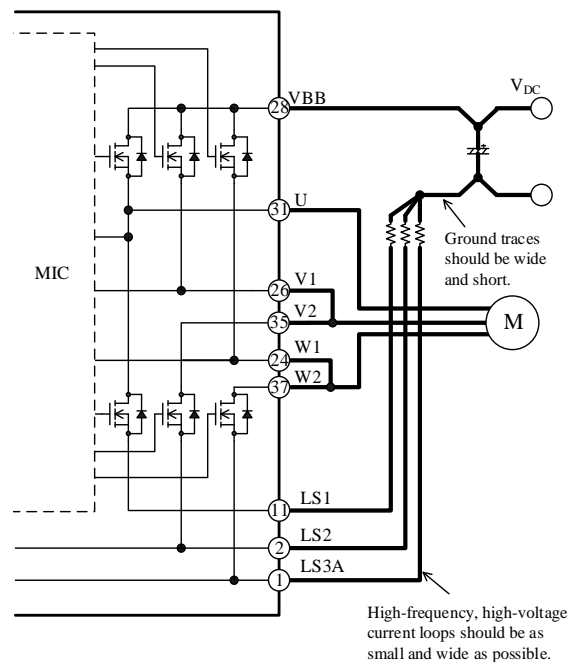

Figure 13-1. High-frequency, High-voltage Current Paths

13.2 Considerations in Heatsink Mounting

The following are the key considerations and the guidelines for mounting a heatsink:

- Be sure to use a metric screw of M2.5 and a plain washer of 6.0 mm (ϕ). When tightening the screws, use a torque screwdriver and tighten them within the range of screw torque defined in Section 4. Be sure to avoid uneven tightening. Temporarily tighten the two screws first, then tighten them equally on both sides until the specified screw torque is reached.
- When mounting a heatsink, it is recommended to use silicone greases. If a thermally conductive sheet or an electrically insulating sheet is used, package cracks may be occurred due to creases at screw tightening. Therefore, you should conduct thorough evaluations before using these materials.
- When applying a silicone grease, make sure that there are no foreign substances between the IC and a heatsink. Extreme care should be taken not to apply a silicone grease onto any device pins as much as possible. The following requirements must be met for proper grease application:
 - Grease thickness: 100 μm
 - Heatsink flatness: $\pm 100\text{ } \mu\text{m}$
 - Apply a silicone grease within the area indicated in Figure 13-2, below.

SIM689xM Series

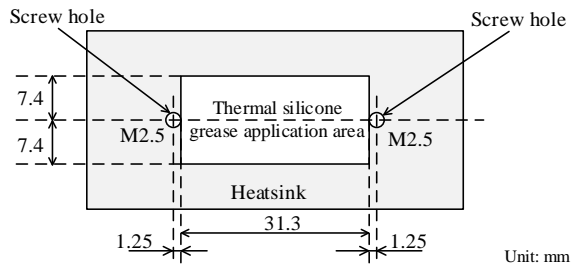

Figure 13-2. Reference Application Area for Thermal Silicone Grease

13.3 Considerations in IC Characteristics Measurement

When measuring the breakdown voltage or leakage current of the transistors incorporated in the IC, note that the gate and source (emitter) of each transistor should have the same potential. Moreover, care should be taken during the measurement because each transistor is connected as follows:

- All the high-side drains (collectors) are internally connected to the VBB pin.
- In the U-phase, the high-side source (emitter) and the low-side drain (collector) are internally connected to the U pin. (In the V- and W-phases, the high- and low-side transistors are unconnected inside the IC.)

The gates of the high-side transistors are pulled down to the corresponding output (U, V/V1, and W1) pins; similarly, the gates of the low-side transistors are pulled down to the COM2 pin. When measuring the breakdown voltage or leakage current of the transistors, note that all of the output (U, V, and W1), LSx, and COMx pins must be appropriately connected. Otherwise, the output transistors may result in permanent damage.

The following are circuit diagrams representing typical measurement circuits for breakdown voltage: Figure 13-3 shows the high-side transistor (Q_{1H}) in the U-phase; Figure 13-4 shows the low-side transistor (Q_{1L}) in the U-phase. And all the pins that are not represented in these figures are open. When measuring the high-side transistors, leave all the non-measuring pins open. When measuring the low-side transistors, connect only the measuring LSx pin to the COMx pin and leave the other pins open.

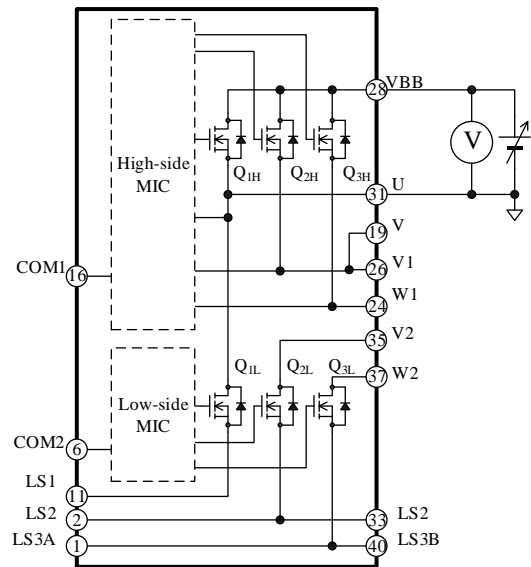

Figure 13-3. Typical Measurement Circuit for High-side Transistor (Q_{1H}) in U-phase

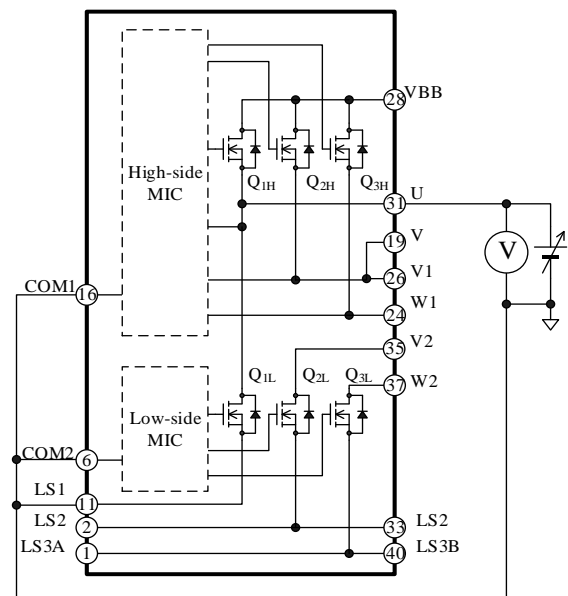

Figure 13-4. Typical Measurement Circuit for Low-side Transistor (Q_{1L}) in U-phase

SIM689xM Series

14. Calculating Power Losses and Estimating Junction Temperatures

This section describes the procedures to calculate power losses in an output transistor, and to estimate a junction temperature (in all-element operation). Note that the descriptions listed here are applicable to the SIM689xM series, which is controlled by a 3-phase sine-wave PWM driving strategy.

For quick and easy references, we offer calculation support tools online. Please visit our website to find out more.

- DT0050: Motor Driver ICs (with Power MOSFETs) Power Loss Calculation Tool
https://www.semicon.sanken-ele.co.jp/en/calc-tool/mosfet_caltool_en.html
- DT0107: Motor Driver ICs (with IGBTs) Power Loss Calculation Tool
https://www.semicon.sanken-ele.co.jp/en/calc-tool/igbtall_caltool2_en.html

14.1 IGBT

Total power loss in an output transistor can be obtained by taking the sum of IGBT steady-state loss, P_{ON} , IGBT switching loss, P_{SW} , and freewheeling diode steady-state loss, P_F . The following subsections contain the mathematical procedures to calculate these losses (P_{ON} , P_{SW} , and P_F) and the junction temperature of all IGBTs and freewheeling diodes operating.

14.1.1 IGBT Steady-state Loss, P_{ON}

Steady-state loss in an IGBT can be computed by using the $V_{CE(SAT)}$ vs. I_C curves, listed in Section 15.3.1. As expressed by the curves in Figure 14-1, a linear approximation at a range the I_C is actually used is obtained by: $V_{CE(SAT)} = \alpha \times I_C + \beta$. The values gained by the above calculation are then applied as parameters in Equation (4), below. Hence, the equation to obtain the IGBT steady-state loss, P_{ON} , is:

$$\begin{aligned} P_{ON} &= \frac{1}{2\pi} \int_0^\pi V_{CE(SAT)}(\varphi) \times I_C(\varphi) \times DT \times d\varphi \\ &= \frac{1}{2} \alpha \left(\frac{1}{2} + \frac{4}{3\pi} M \times \cos \theta \right) I_M^2 \\ &\quad + \frac{\sqrt{2}}{\pi} \beta \left(\frac{1}{2} + \frac{\pi}{8} M \times \cos \theta \right) I_M. \end{aligned} \quad (4)$$

Where:

$V_{CE(SAT)}$ is the collector-to-emitter saturation voltage of the IGBT (V),

I_C is the collector current of the IGBT (A),
DT is the duty cycle, which is given by

$$DT = \frac{1 + M \times \sin(\varphi + \theta)}{2},$$

M is the modulation index (0 to 1),

$\cos \theta$ is the motor power factor (0 to 1),

I_M is the effective motor current (A),

α is the slope of the linear approximation in the $V_{CE(SAT)}$ vs. I_C curve, and

β is the intercept of the linear approximation in the $V_{CE(SAT)}$ vs. I_C curve.

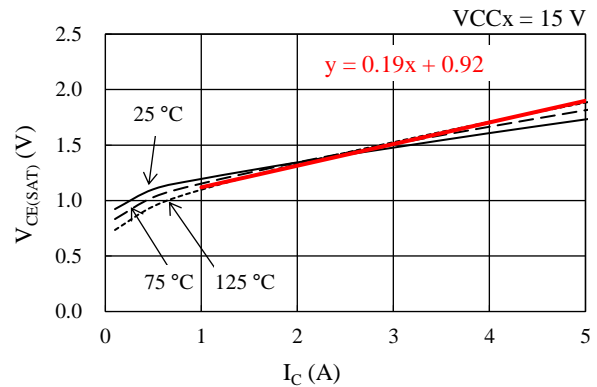

Figure 14-1. Linear Approximate Equation of $V_{CE(SAT)}$ vs. I_C

14.1.2 IGBT Switching Loss, P_{SW}

Switching loss in an IGBT can be calculated by Equation (5), letting I_M be the effective current value of the motor:

$$P_{SW} = \frac{\sqrt{2}}{\pi} \times f_C \times \alpha_E \times I_M \times \frac{V_{DC}}{300}. \quad (5)$$

Where:

f_C is the PWM carrier frequency (Hz),

V_{DC} is the main power supply voltage (V), i.e., the VBB pin input voltage, and

α_E is the slope of the switching loss curve (see Section 14.1.2).

SIM689xM Series

14.1.3 Estimating Junction Temperature of IGBT

The junction temperature of all IGBTs operating, T_J , can be estimated with Equation (6):

$$T_J = R_{(J-C)Q} \times \{(P_{ON} + P_{SW}) \times 6\} + T_C \quad (6)$$

Where:

$R_{(J-C)Q}$ is the junction-to-case thermal resistance ($^{\circ}\text{C}/\text{W}$) of all the IGBTs operating, and
 T_C is the case temperature ($^{\circ}\text{C}$), measured at the point defined in Figure 3-1.

14.1.4 Freewheeling Diode Steady-state Loss, P_F

Steady-state loss in a freewheeling diode can be computed by using the V_F vs. I_F curves, listed in Section 15.3.1. As expressed by the curves in Figure 14-2, a linear approximation at a range the I_F is actually used is obtained by: $V_F = \alpha \times I_F + \beta$.

The values gained by the above calculation are then applied as parameters in Equation (7), below. Hence, the equation to obtain the freewheeling diode steady-state loss, P_F , is:

$$P_F = \frac{1}{2\pi} \int_0^{\pi} V_F(\varphi) \times I_F(\varphi) \times (1 - DT) \times d\varphi$$

$$= \frac{1}{2} \alpha \left(\frac{1}{2} - \frac{4}{3\pi} M \times \cos \theta \right) I_M^2 + \frac{\sqrt{2}}{\pi} \beta \left(\frac{1}{2} - \frac{\pi}{8} M \times \cos \theta \right) I_M \quad (7)$$

Where:

V_F is the forward voltage of the freewheeling diode (V),
 I_F is the forward current of the freewheeling diode (A),
 DT is the duty cycle, which is given by

$$DT = \frac{1 + M \times \sin(\varphi + \theta)}{2},$$

M is the modulation index (0 to 1),
 $\cos \theta$ is the motor power factor (0 to 1),
 I_M is the effective motor current (A),
 α is the slope of the linear approximation in the V_F vs. I_F curve, and
 β is the intercept of the linear approximation in the V_F vs. I_F curve.

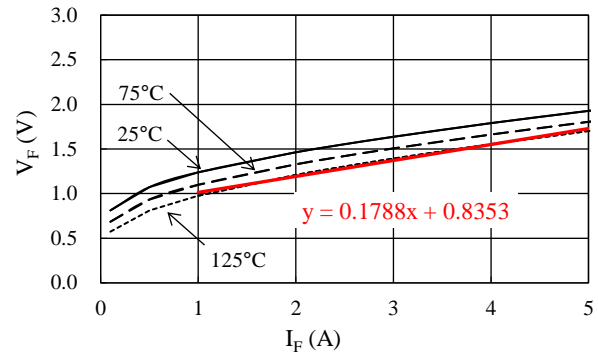

Figure 14-2. Linear Approximate Equation of V_F vs. I_F

14.1.5 Estimating Junction Temperature of Freewheeling Diode

The junction temperature of all freewheeling diodes operating, T_J , can be estimated with Equation (8):

$$T_J = R_{(J-C)F} \times (P_F \times 6) + T_C \quad (8)$$

Where:

$R_{(J-C)F}$ is the junction-to-case thermal resistance ($^{\circ}\text{C}/\text{W}$) of all the freewheeling diodes operating, and
 T_C is the case temperature ($^{\circ}\text{C}$), measured at the point defined in Figure 3-1.

SIM689xM Series

14.2 Power MOSFET

Total power loss in a power MOSFET can be obtained by taking the sum of the following losses: steady-state loss, P_{RON} ; switching loss, P_{SW} ; the steady-state loss of a body diode, P_{SD} . In the calculation procedure we offer, the recovery loss of a body diode, P_{RR} , is considered negligibly small compared with the ratios of other losses.

The following subsections contain the mathematical procedures to calculate these losses (P_{RON} , P_{SW} , and P_{SD}) and the junction temperature of all power MOSFETs operating.

14.2.1 Power MOSFET Steady-state Loss, P_{RON}

Steady-state loss in a power MOSFET can be computed by using the $R_{DS(ON)}$ vs. I_D curves, listed in Section 15.3.1. As expressed by the curves in Figure 14-3, a linear approximation at a range the I_D is actually used is obtained by: $R_{DS(ON)} = \alpha \times I_D + \beta$. The values gained by the above calculation are then applied as parameters in Equation (9), below. Hence, the equation to obtain the power MOSFET steady-state loss, P_{RON} , is:

$$\begin{aligned} P_{RON} &= \frac{1}{2\pi} \int_0^\pi I_D(\varphi)^2 \times R_{DS(ON)}(\varphi) \times DT \times d\varphi \\ &= 2\sqrt{2}\alpha \left(\frac{1}{3\pi} + \frac{3}{32} M \times \cos\theta \right) I_M^3 \\ &\quad + 2\beta \left(\frac{1}{8} + \frac{1}{3\pi} M \times \cos\theta \right) I_M^2. \end{aligned} \quad (9)$$

Where:

I_D is the drain current of the power MOSFET (A),
 $R_{DS(ON)}$ is the drain-to-source on-resistance of the power MOSFET (Ω),
 DT is the duty cycle, which is given by

$$DT = \frac{1 + M \times \sin(\varphi + \theta)}{2},$$

M is the modulation index (0 to 1),
 $\cos\theta$ is the motor power factor (0 to 1),
 I_M is the effective motor current (A),
 α is the slope of the linear approximation in the $R_{DS(ON)}$ vs. I_D curve, and
 β is the intercept of the linear approximation in the $R_{DS(ON)}$ vs. I_D curve.

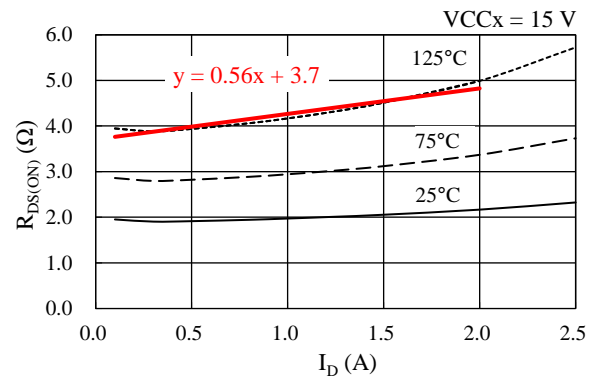

Figure 14-3. Linear Approximate Equation of $R_{DS(ON)}$ vs. I_D

14.2.2 Power MOSFET Switching Loss, P_{SW}

Switching loss in a power MOSFET can be calculated by Equation (10), letting I_M be the effective current value of the motor:

$$P_{SW} = \frac{\sqrt{2}}{\pi} \times f_c \times \alpha_E \times I_M \times \frac{V_{DC}}{300}. \quad (10)$$

Where:

f_c is the PWM carrier frequency (Hz),
 V_{DC} is the main power supply voltage (V), i.e., the VBB pin input voltage, and
 α_E is the slope of the switching loss curve (see Section 14.2.2).

14.2.3 Body Diode Steady-state Loss, P_{SD}

Steady-state loss in the body diode of a power MOSFET can be computed by using the V_{SD} vs. I_{SD} curves, listed in Section 15.3.1. As expressed by the curves in Figure 14-4, a linear approximation at a range the I_{SD} is actually used is obtained by: $V_{SD} = \alpha \times I_{SD} + \beta$. The values gained by the above calculation are then applied as parameters in Equation (11), below. Hence, the equation to obtain the body diode steady-state loss, P_{SD} , is:

$$\begin{aligned} P_{SD} &= \frac{1}{2\pi} \int_0^\pi V_{SD}(\varphi) \times I_{SD}(\varphi) \times (1 - DT) \times d\varphi \\ &= \frac{1}{2} \alpha \left(\frac{1}{2} - \frac{4}{3\pi} M \times \cos\theta \right) I_M^2 \\ &\quad + \frac{\sqrt{2}}{\pi} \beta \left(\frac{1}{2} - \frac{\pi}{8} M \times \cos\theta \right) I_M. \end{aligned} \quad (11)$$

Where:

SIM689xM Series

V_{SD} is the source-to-drain diode forward voltage of the power MOSFET (V),

I_{SD} is the source-to-drain diode forward current of the power MOSFET (A),

DT is the duty cycle, which is given by

$$DT = \frac{1 + M \times \sin(\varphi + \theta)}{2},$$

M is the modulation index (0 to 1),

$\cos\theta$ is the motor power factor (0 to 1),

I_M is the effective motor current (A),

α is the slope of the linear approximation in the V_{SD} vs. I_{SD} curve, and

β is the intercept of the linear approximation in the V_{SD} vs. I_{SD} curve.

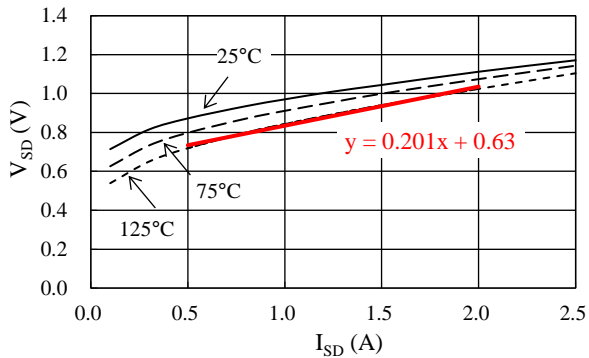

Figure 14-4. Linear Approximate Equation of V_{SD} vs. I_{SD}

14.2.4 Estimating Junction Temperature of Power MOSFET

The junction temperature of all power MOSFETs operating, T_J , can be estimated with Equation (12):

$$T_J = R_{J-C} \times \{(P_{ON} + P_{SW} + P_{SD}) \times 6\} + T_C. \quad (12)$$

Where:

R_{J-C} is the junction-to-case thermal resistance ($^{\circ}\text{C}/\text{W}$) of all the power MOSFETs operating, and

T_C is the case temperature ($^{\circ}\text{C}$), measured at the point defined in Figure 3-1.

SIM689xM Series

15. Performance Curves

15.1 Performance Curves of Control Parts

Figure 15-1 to Figure 15-23 provide performance curves of the control parts integrated in the SIM689xM series, including variety-dependent characteristics and thermal characteristics. T_J represents the junction temperature of the control parts.

Table 15-1. Typical Characteristics of Control Parts

Figure Number	Figure Caption
Figure 15-1	Logic Supply Current, I_{CC} vs. T_C ($I_{N_x} = 0$ V)
Figure 15-2	Logic Supply Current, I_{CC} vs. T_C ($I_{N_x} = 5$ V)
Figure 15-3	VCCx Pin Voltage, V_{CC} vs. Logic Supply Current, I_{CC}
Figure 15-4	Logic Supply Current (1-phase) I_{BS} vs. T_C ($HIN_x = 0$ V)
Figure 15-5	Logic Supply Current (1-phase) I_{BS} vs. T_C ($HIN_x = 5$ V)
Figure 15-6	VBx Pin Voltage, V_B vs. Logic Supply Current, I_{BS} ($HIN_x = 0$ V)
Figure 15-7	Logic Operation Start Voltage, $V_{BS(ON)}$ vs. T_C
Figure 15-8	Logic Operation Stop Voltage, $V_{BS(OFF)}$ vs. T_C
Figure 15-9	Logic Operation Start Voltage, $V_{CC(ON)}$ vs. T_C
Figure 15-10	Logic Operation Stop Voltage, $V_{CC(OFF)}$ vs. T_C
Figure 15-11	UVLO_VB Filtering Time vs. T_C
Figure 15-12	UVLO_VCC Filtering Time vs. T_C
Figure 15-13	High Level Input Threshold Voltage, V_{IH} vs. T_C
Figure 15-14	Low Level Input Threshold Voltage, V_{IL} vs. T_C
Figure 15-15	Input Current at High Level (HIN_x or LIN_x), I_{IN} vs. T_C
Figure 15-16	High-side Turn-on Propagation Delay vs. T_C (from HIN_x to HO_x)
Figure 15-17	Low-side Turn-on Propagation Delay vs. T_C (from LIN_x to LO_x)
Figure 15-18	Minimum Transmittable Pulse Width for High-side Switching, $t_{HIN(MIN)}$ vs. T_C
Figure 15-19	Minimum Transmittable Pulse Width for Low-side Switching, $t_{LIN(MIN)}$ vs. T_C
Figure 15-20	OCP Threshold Voltage, V_{TRIP} vs. T_C
Figure 15-21	OCP Hold Time, t_P vs. T_C
Figure 15-22	OCP Blanking Time, $t_{BK(OCP)}$ + Propagation Delay, t_D vs. T_C
Figure 15-23	FO Pin Voltage in Normal Operation, V_{FOL} vs. T_C

SIM689xM Series

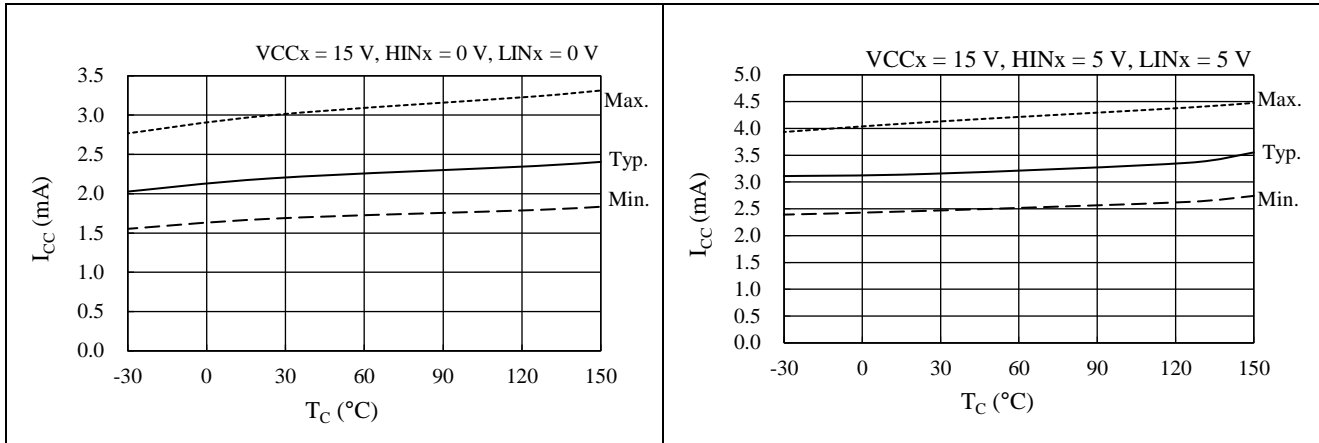
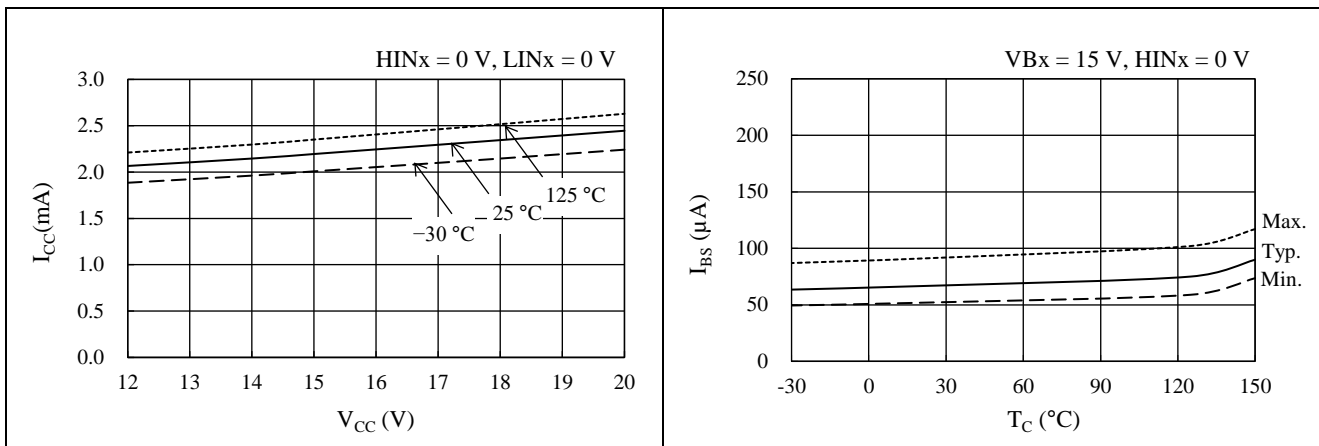
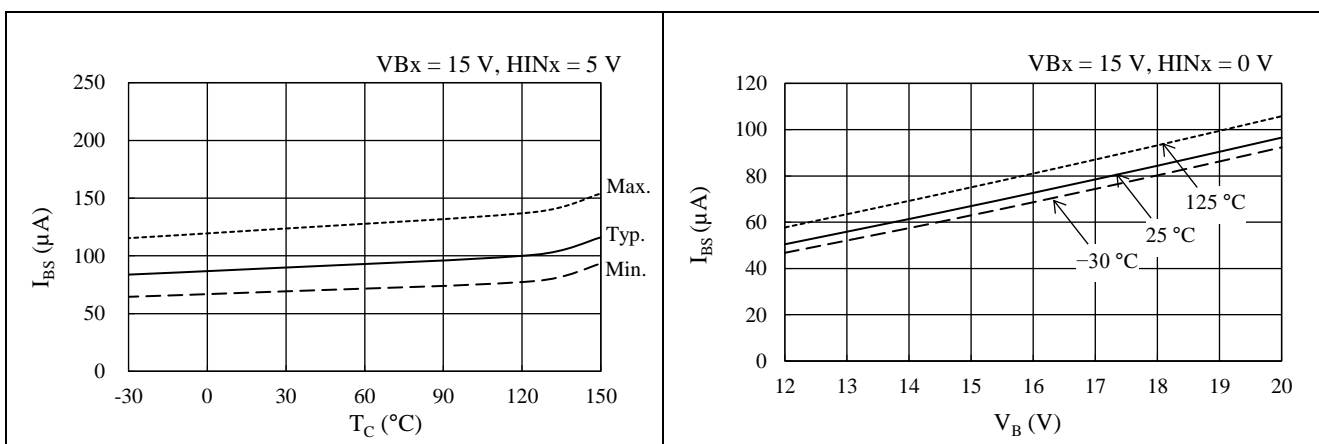
Figure 15-1. Logic Supply Current, I_{CC} vs. T_C ($I_{N_x} = 0$ V)Figure 15-2. Logic Supply Current, I_{CC} vs. T_C ($I_{N_x} = 5$ V)Figure 15-3. V_{CCx} Pin Voltage, V_{CC} vs. Logic Supply Current, I_{CC} curveFigure 15-4. Logic Supply Current (1-phase) I_{BS} vs. T_C ($H_{INx} = 0$ V)Figure 15-5. Logic Supply Current (1-phase) I_{BS} vs. T_C ($H_{INx} = 5$ V)Figure 15-6. V_{Bx} Pin Voltage, V_B vs. Logic Supply Current, I_{BS} ($H_{INx} = 0$ V)

SIM689xM Series

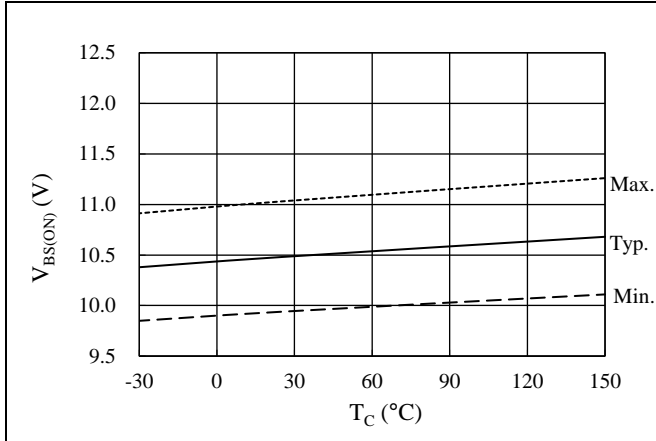
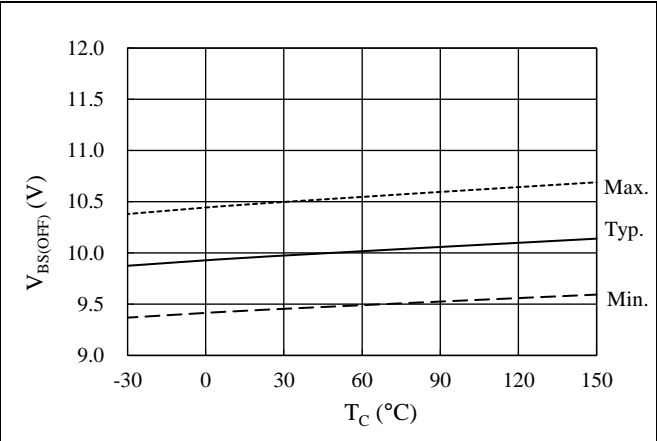
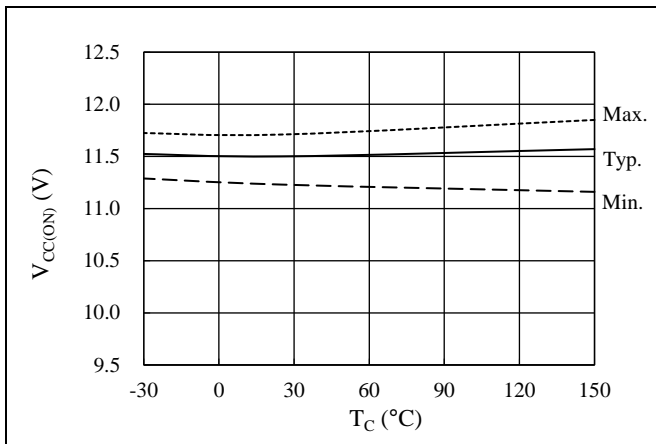
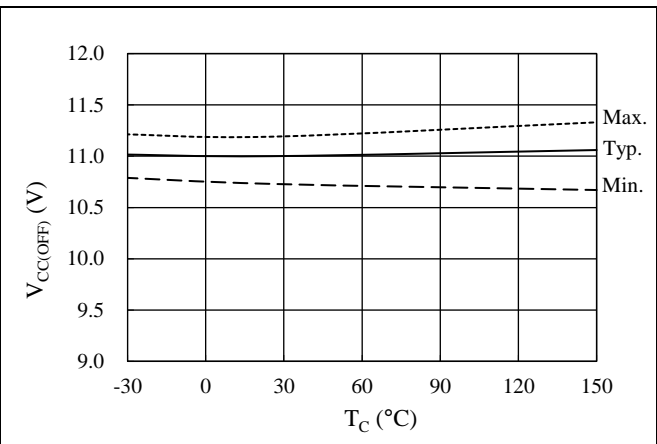
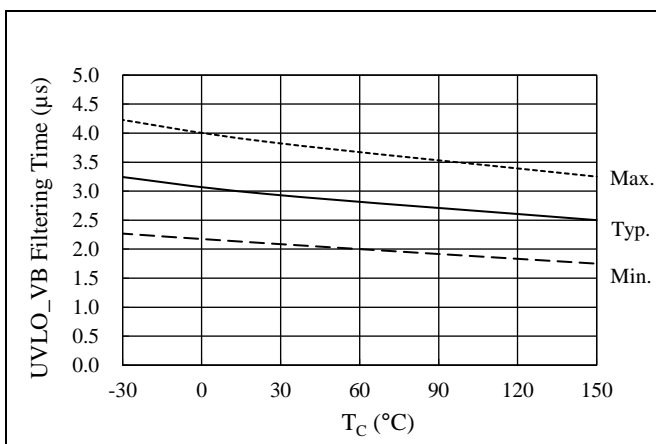
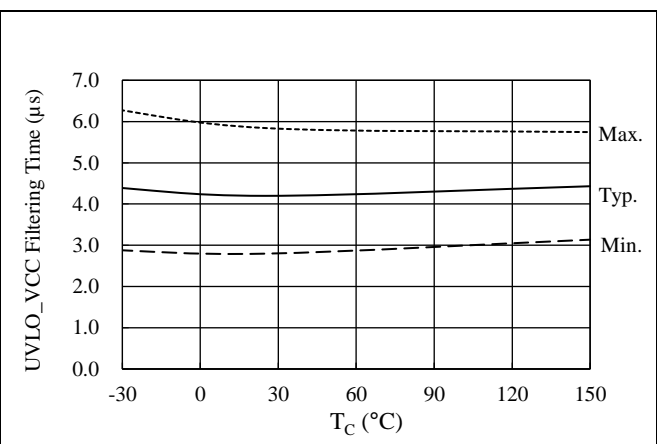
Figure 15-7. Logic Operation Start Voltage, $V_{BS(ON)}$ vs. T_C Figure 15-8. Logic Operation Stop Voltage, $V_{BS(OFF)}$ vs. T_C Figure 15-9. Logic Operation Start Voltage, $V_{CC(ON)}$ vs. T_C Figure 15-10. Logic Operation Stop Voltage, $V_{CC(OFF)}$ vs. T_C Figure 15-11. UVLO_VB Filtering Time vs. T_C Figure 15-12. UVLO_VCC Filtering Time vs. T_C

SIM689xM Series

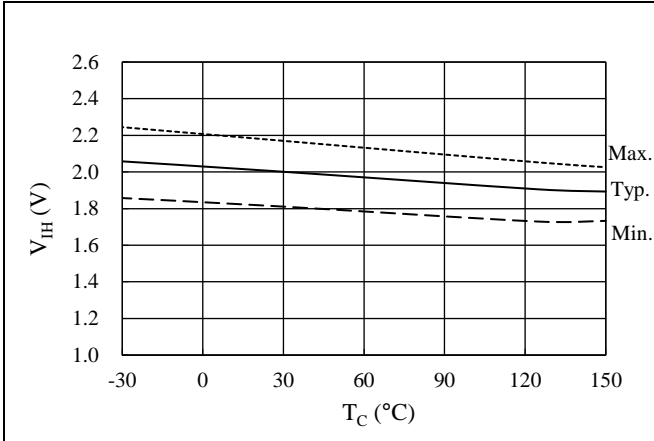
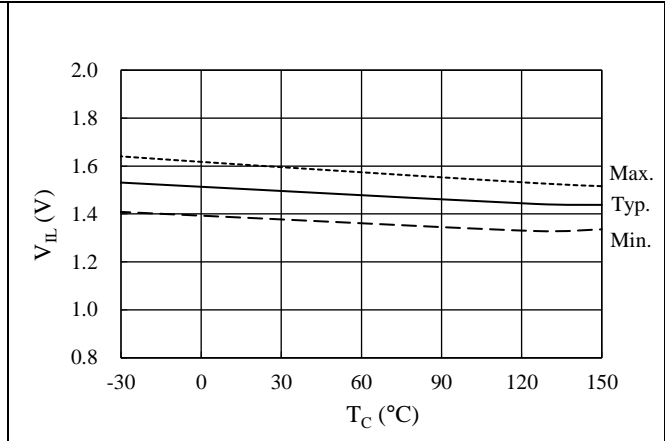
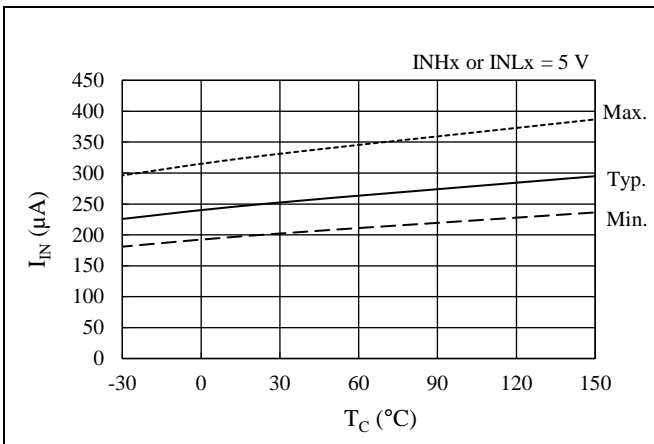
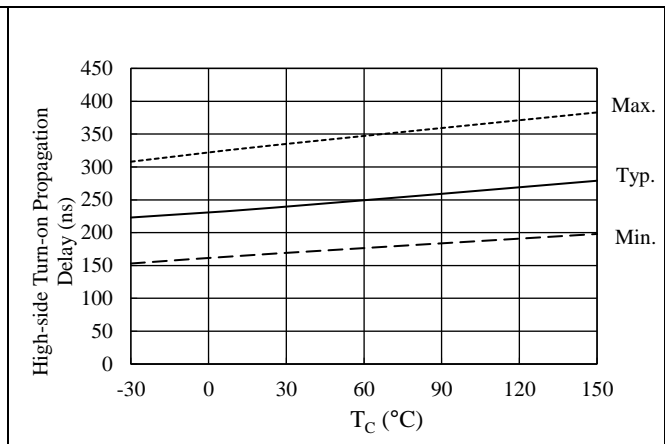
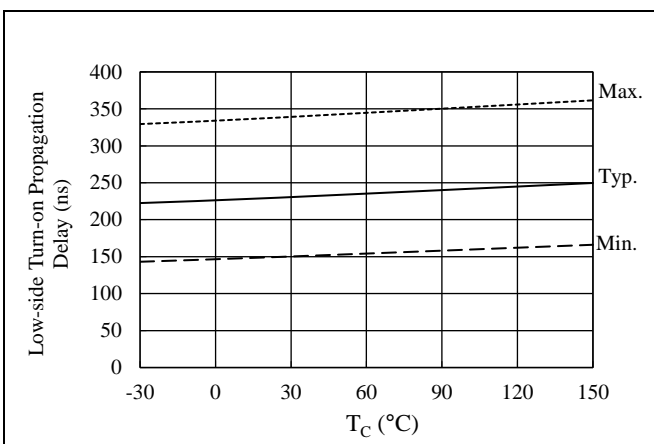
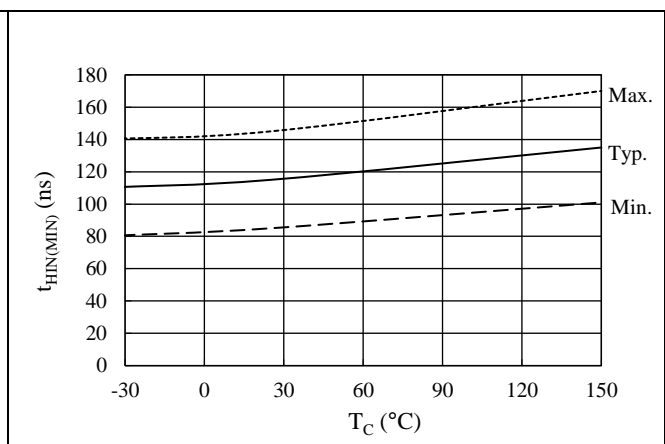
Figure 15-13. High Level Input Threshold Voltage, V_{IH} vs. T_CFigure 15-14. Low Level Input Threshold Voltage, V_{IL} vs. T_CFigure 15-15. Input Current at High Level (HINx or LINx), I_{IN} vs. T_CFigure 15-16. High-side Turn-on Propagation Delay vs. T_C (from HINx to HOx)Figure 15-17. Low-side Turn-on Propagation Delay vs. T_C (from LINx to LOx)Figure 15-18. Minimum Transmittable Pulse Width for High-side Switching, t_{HIN(MIN)} vs. T_C

SIM689xM Series

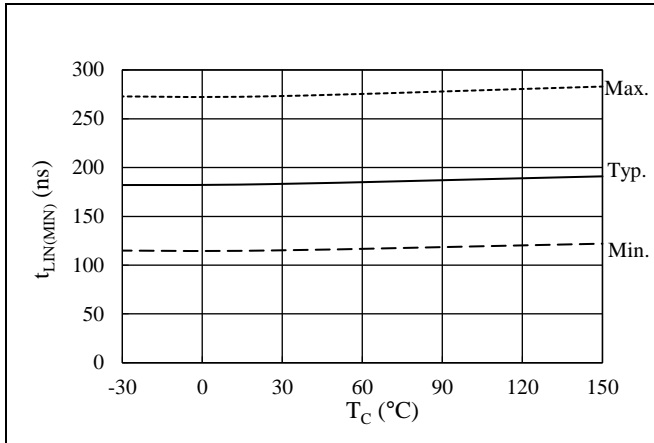

Figure 15-19. Minimum Transmittable Pulse Width for Low-side Switching, $t_{LIN(MIN)}$ vs. T_C

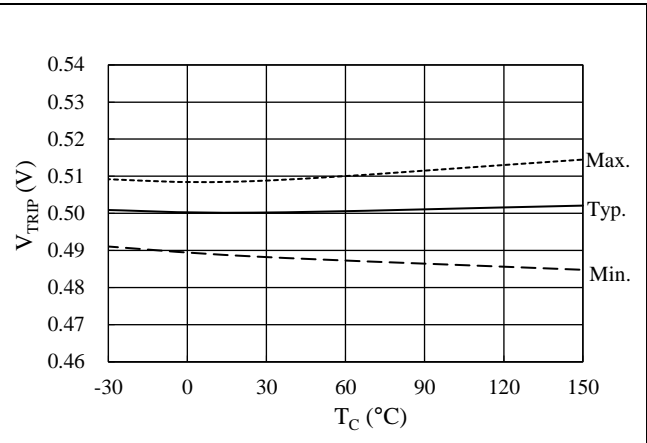

Figure 15-20. OCP Threshold Voltage, V_{TRIP} vs. T_C

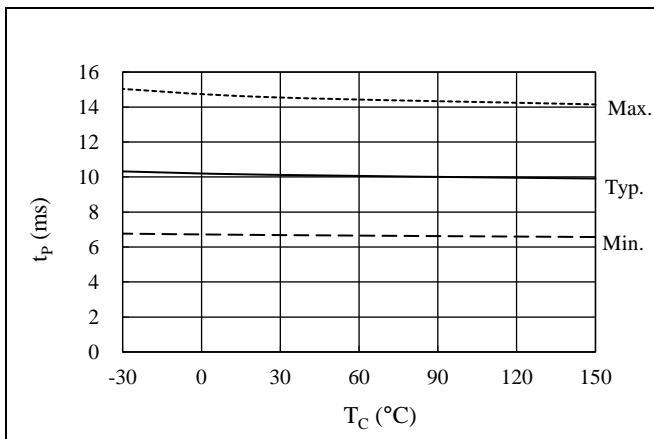

Figure 15-21. OCP Hold Time, t_p vs. T_C

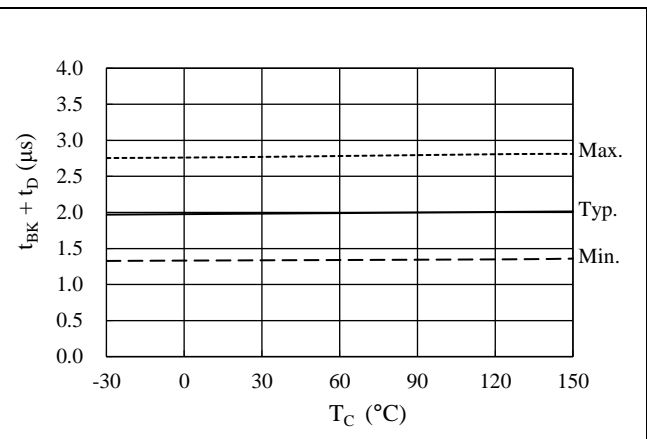

Figure 15-22. OCP Blanking Time, $t_{BK(OCP)}$ + Propagation Delay, t_D vs. T_C
(SIM6891MD/92M/93M/95M/96M)

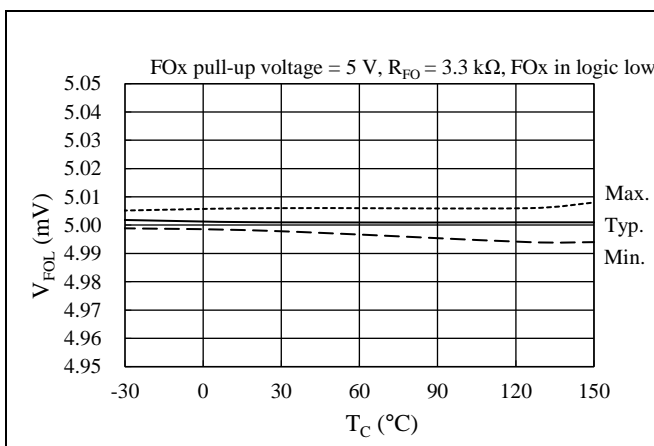

Figure 15-23. FO Pin Voltage in Normal Operation, V_{FOL} vs. T_C

SIM689xM Series

15.2 Transient Thermal Resistance Curves

The following graphs represent transient thermal resistance (the ratios of transient thermal resistance), with steady-state junction-to-case thermal resistance = 1. Note that the graph representing that of the IGBT-embedded device shows only IGBT characteristics; no freewheeling diode characteristics are included.

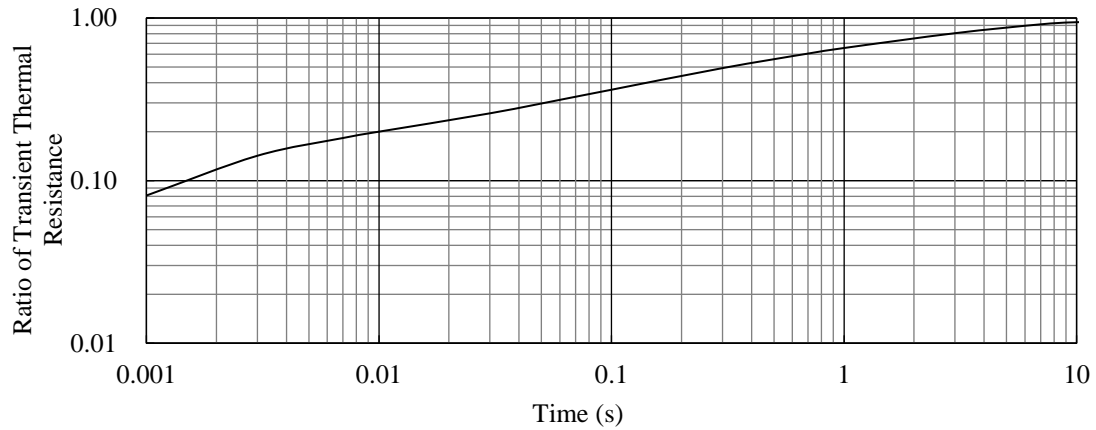

Figure 15-24. Transient Thermal Resistance: SIM6891MD/ SIM6891MDN

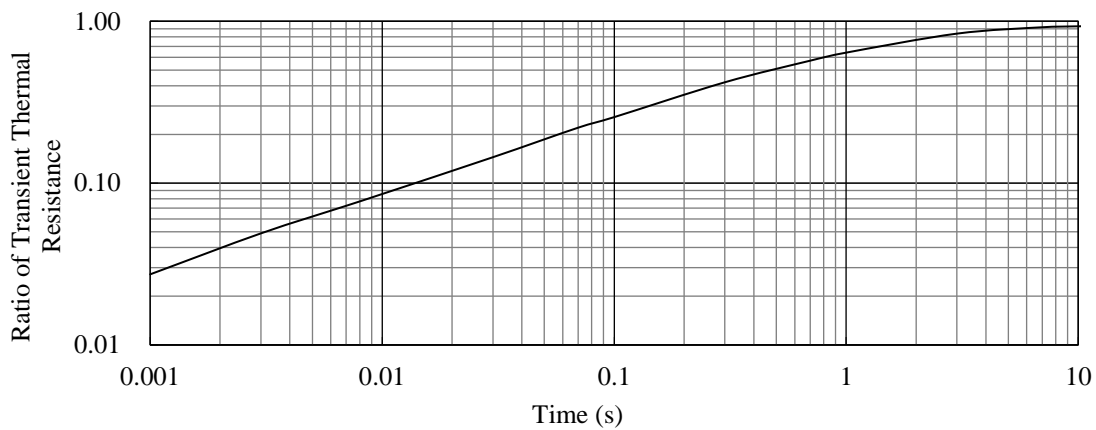

Figure 15-25. Transient Thermal Resistance: SIM6893M

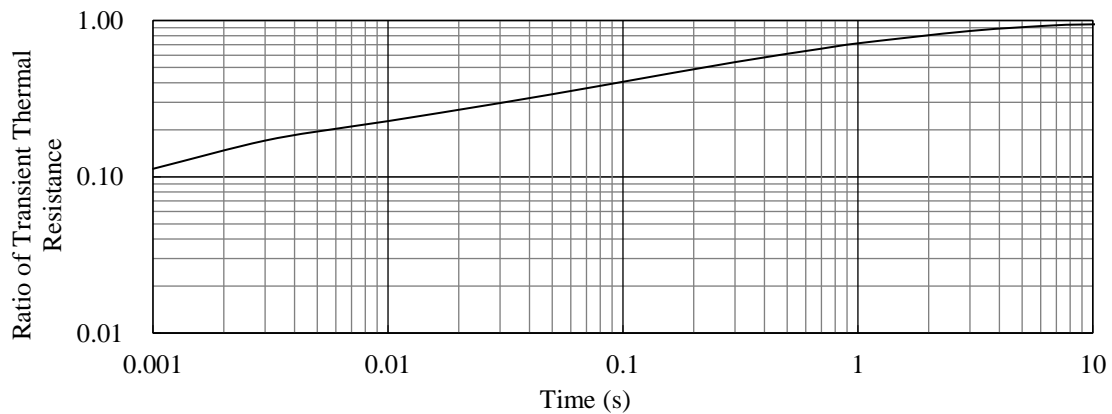

Figure 15-26. Transient Thermal Resistance: SIM6896M

SIM689xM Series

Figure 15-27. Transient Thermal Resistance: SIM6892M/SIM6895M

SIM689xM Series

15.3 Performance Curves of Output Parts

15.3.1 Output Transistor Performance Curves

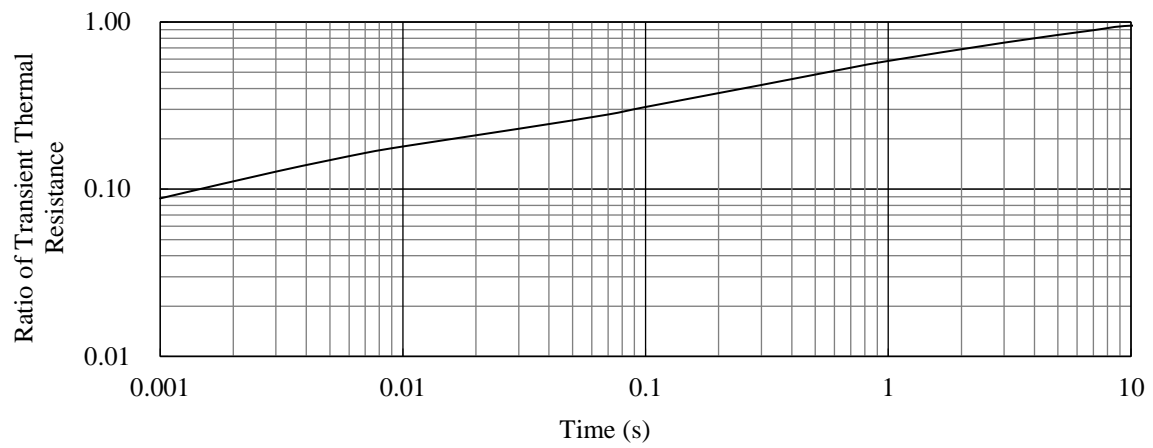
15.3.1.1. SIM6891MD/ SIM6891MDN

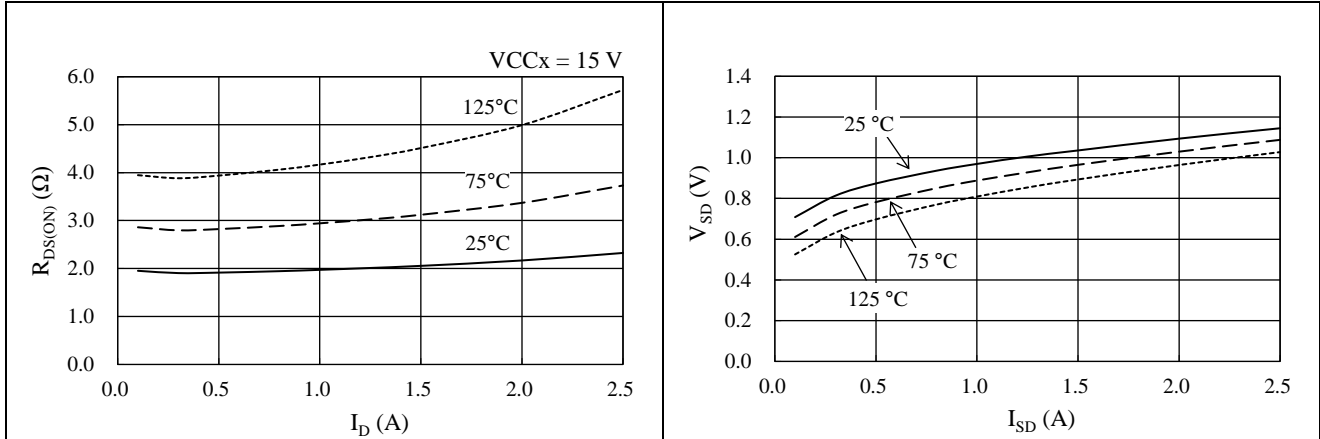
Figure 15-28. Power MOSFET $R_{DS(ON)}$ vs. I_D Figure 15-29. Power MOSFET V_{SD} vs. I_{SD}

15.3.1.2. SIM6893M

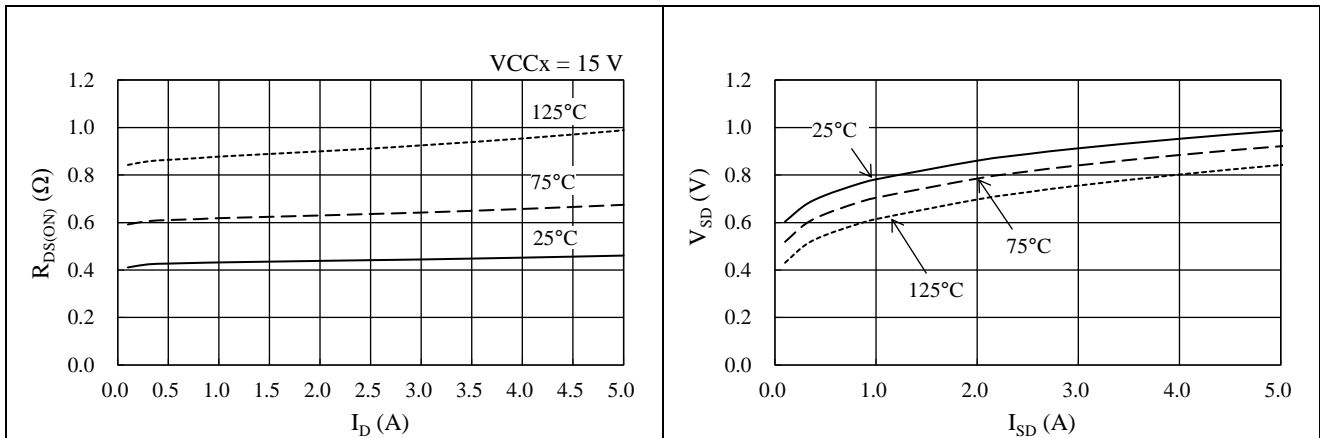
Figure 15-30. Power MOSFET $R_{DS(ON)}$ vs. I_D Figure 15-31. Power MOSFET V_{SD} vs. I_{SD}

SIM689xM Series

15.3.1.3. SIM6896M

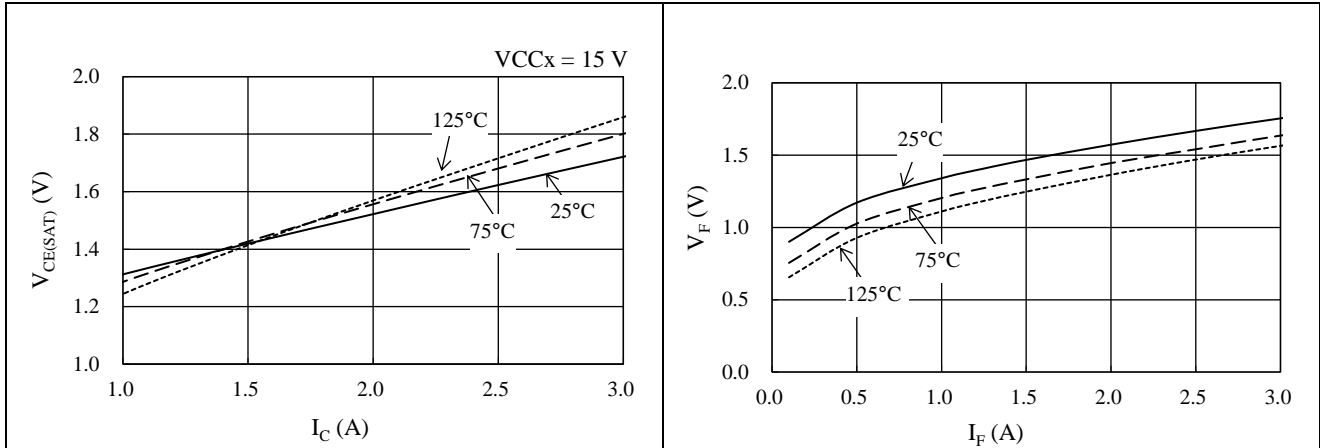
Figure 15-32. IGBT $V_{CE(SAT)}$ vs. I_C Figure 15-33. FRD V_F vs. I_F

15.3.1.4. SIM6892M/SIM6895M

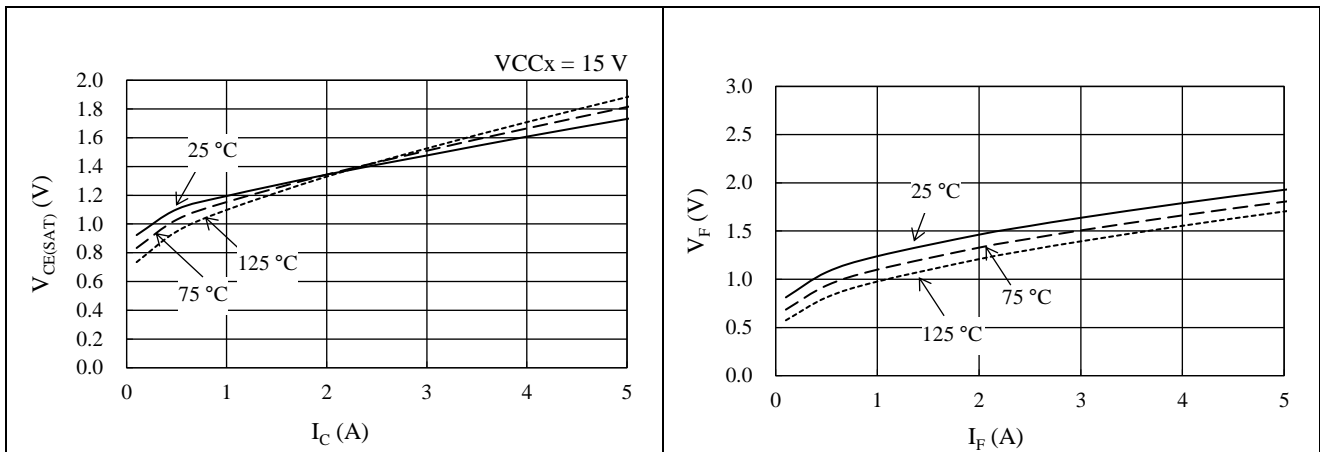
Figure 15-34. IGBT $V_{CE(SAT)}$ vs. I_C Figure 15-35. FRD V_F vs. I_F

SIM689xM Series

15.3.2 Switching Loss Curves

Conditions: VBB pin voltage = 300 V, half-bridge circuit with inductive load.
Switching Loss, E, is the sum of turn-on loss and turn-off loss.

15.3.2.1. SIM6891MD

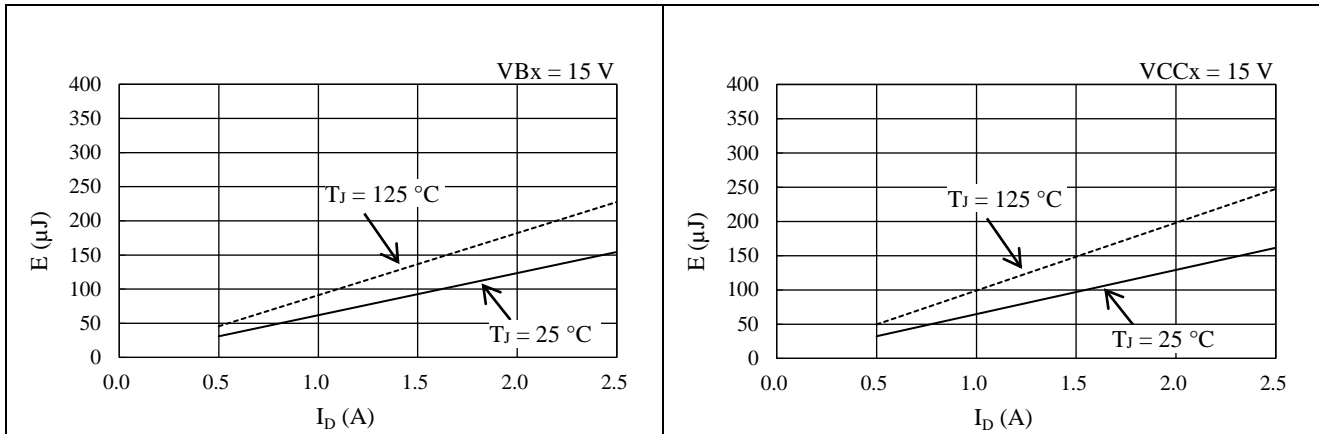

Figure 15-36. High-side Switching Loss

Figure 15-37. Low-side Switching Loss

15.3.2.2. SIM6891MDN

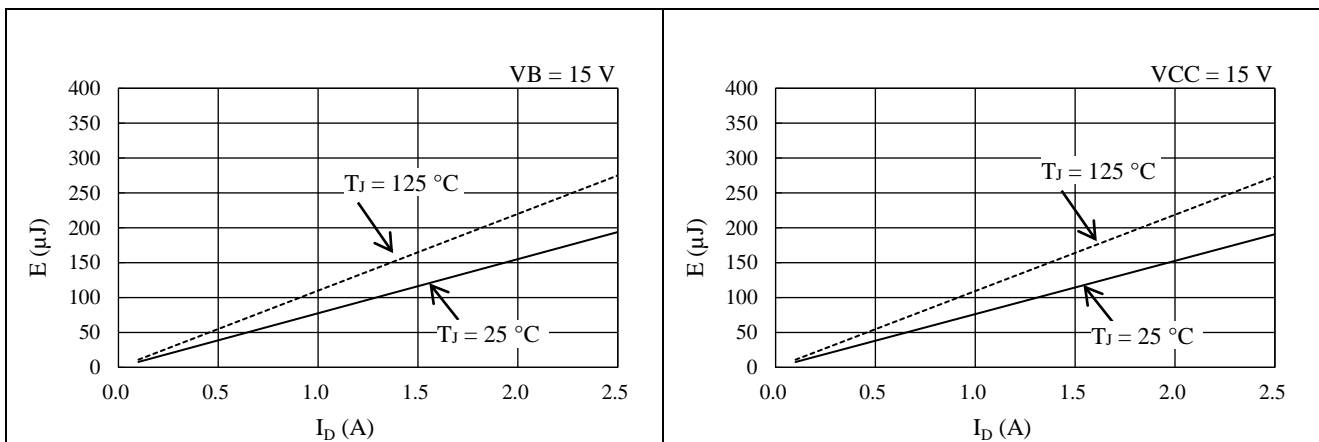

Figure 15-38. High-side Switching Loss

Figure 15-39. Low-side Switching Loss

SIM689xM Series

15.3.2.3. SIM6893M

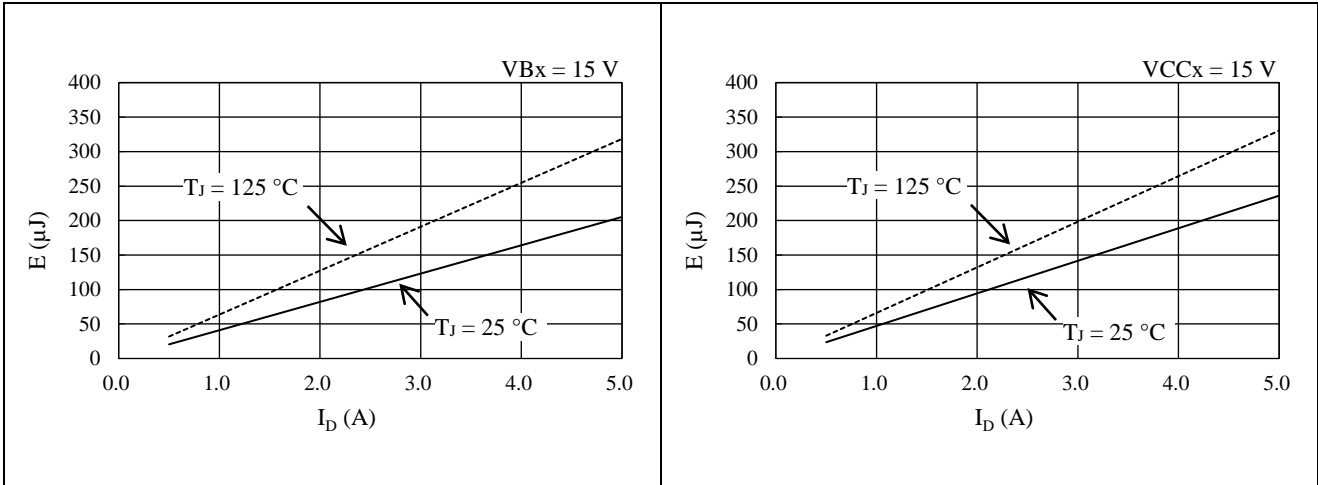

Figure 15-40. High-side Switching Loss

Figure 15-41. Low-side Switching Loss

15.3.2.4. SIM6896M

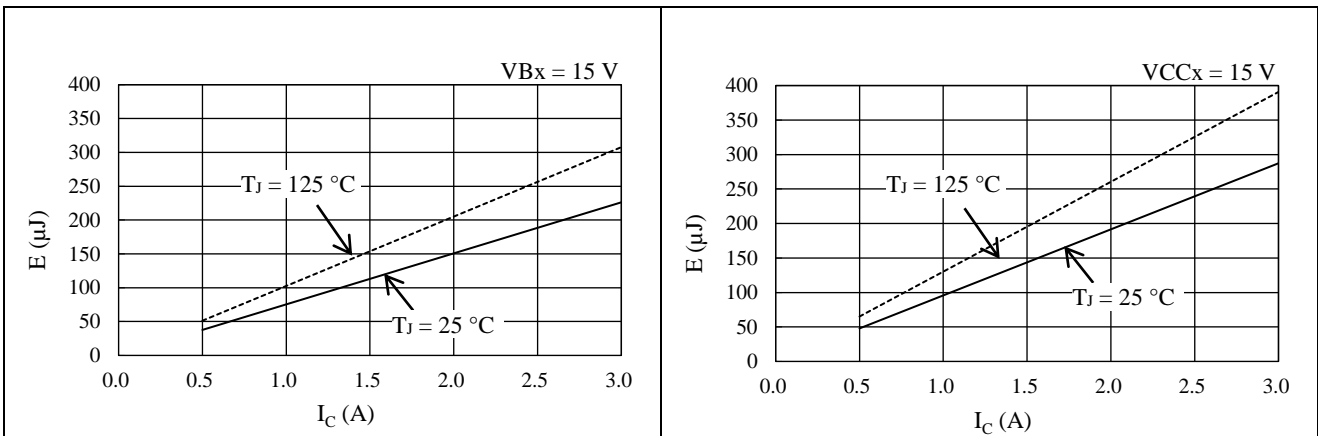

Figure 15-42. High-side Switching Loss

Figure 15-43. Low-side Switching Loss

SIM689xM Series

15.3.2.5. SIM6892M

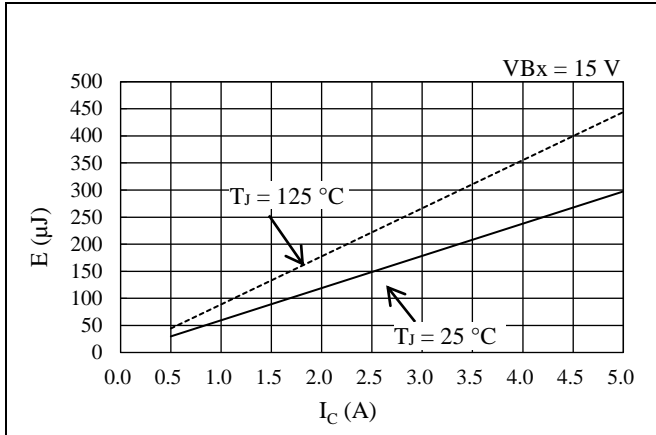

Figure 15-44. High-side Switching Loss

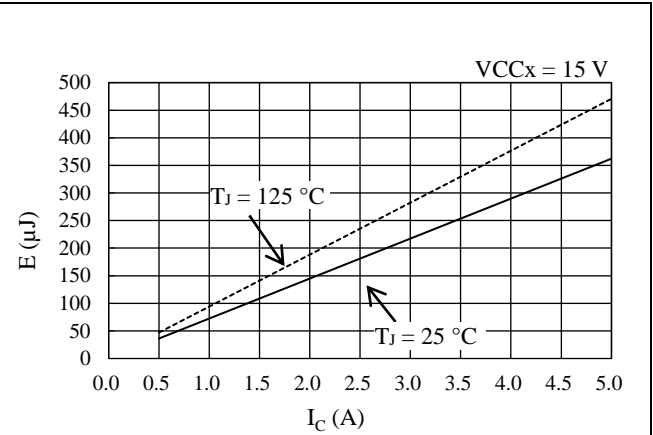

Figure 15-45. Low-side Switching Loss

SIM6895M

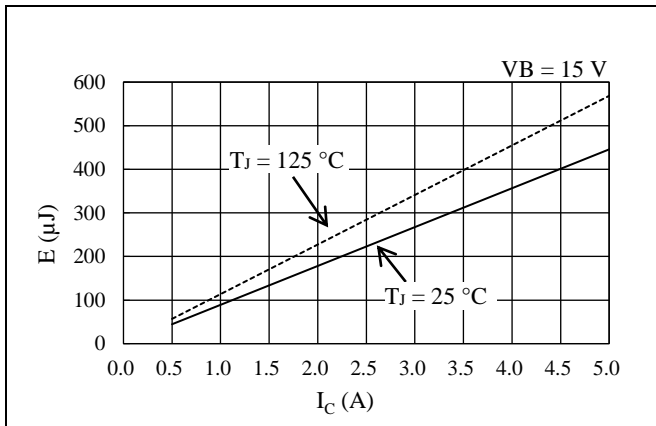

Figure 15-46. High-side Switching Loss

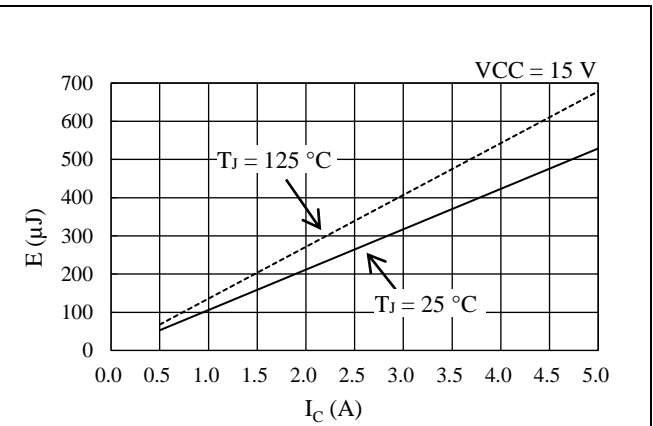

Figure 15-47. Low-side Switching Loss

SIM689xM Series

15.4 Allowable Effective Current Curves

The following curves represent allowable effective currents in 3-phase sine-wave PWM driving with parameters such as typical $R_{DS(ON)}$ or $V_{CE(SAT)}$, and typical switching losses.

Operating conditions: VBB pin input voltage, $V_{DC} = 300$ V; VCC pin input voltage, $V_{CC} = 15$ V; modulation index, $M = 0.9$; motor power factor, $\cos\theta = 0.8$; junction temperature, $T_J = 150$ °C.

15.4.1 SIM6891MD

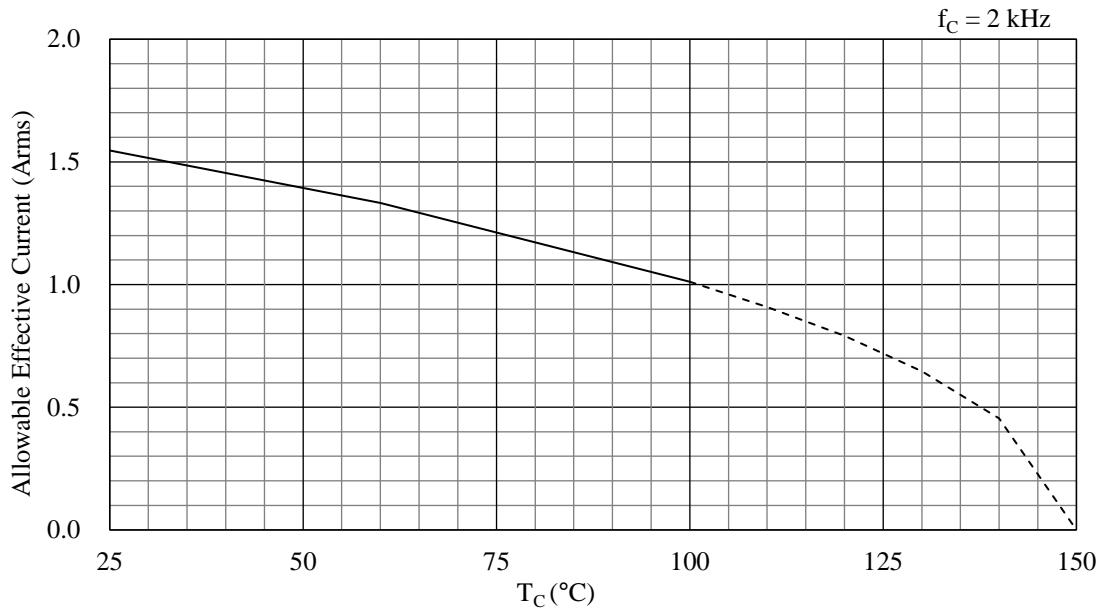

Figure 15-48. Allowable Effective Current ($f_c = 2$ kHz): SIM6891MD

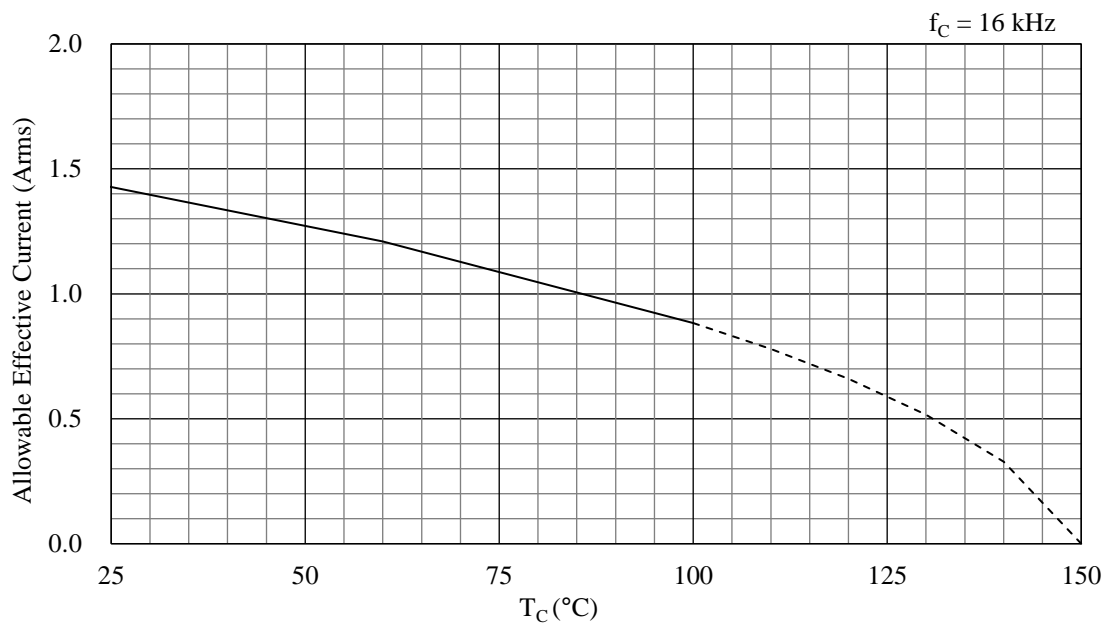

Figure 15-49. Allowable Effective Current ($f_c = 16$ kHz): SIM6891MD

SIM689xM Series

15.4.2 SIM6891MDN

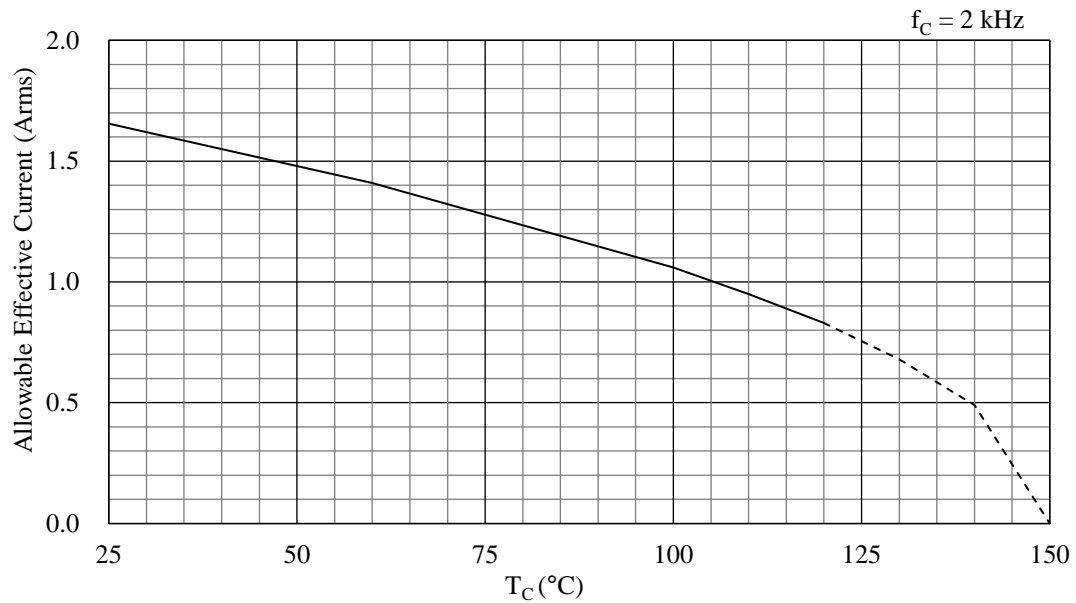

Figure 15-50. Allowable Effective Current ($f_c = 2 \text{ kHz}$): SIM6891MDN

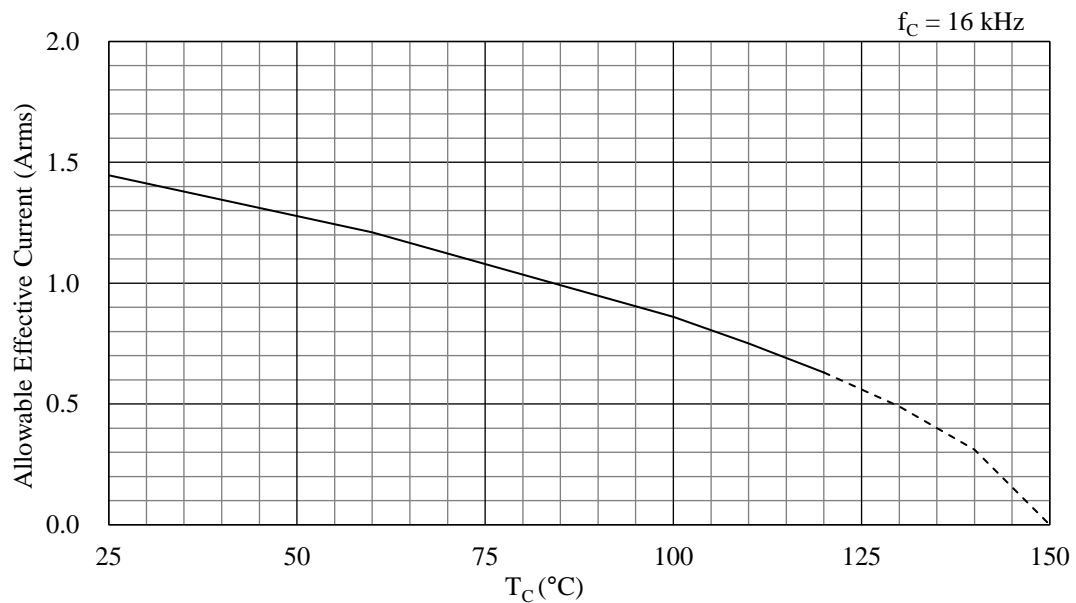

Figure 15-51. Allowable Effective Current ($f_c = 16 \text{ kHz}$): SIM6891MDN

SIM689xM Series

15.4.3 SIM6893M

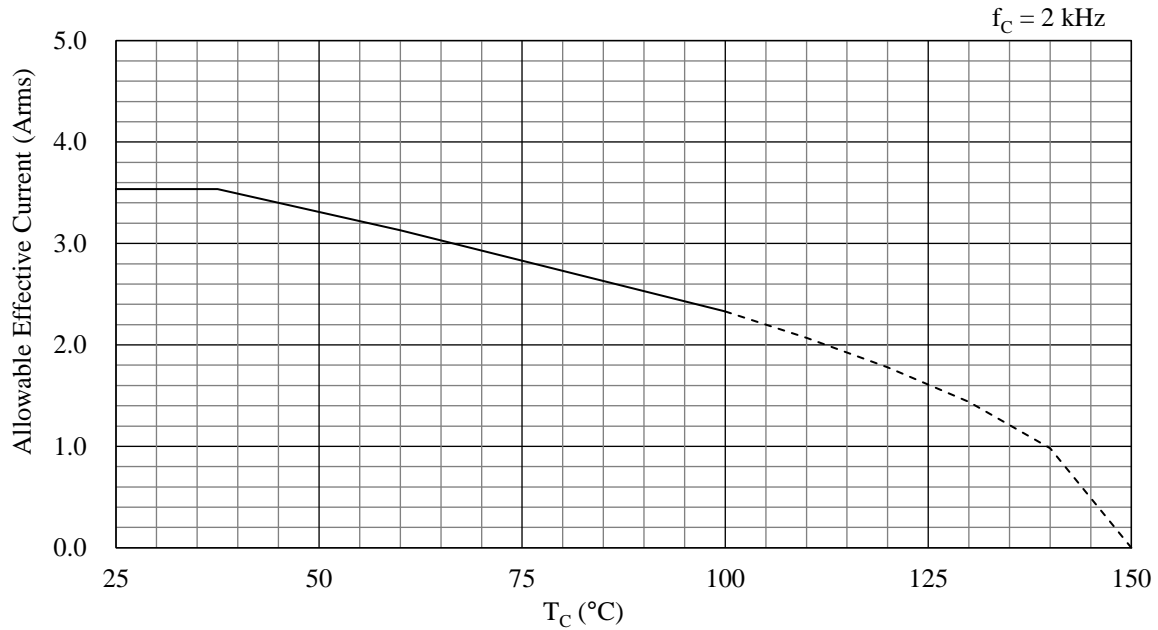

Figure 15-52. Allowable Effective Current ($f_c = 2 \text{ kHz}$): SIM6893M

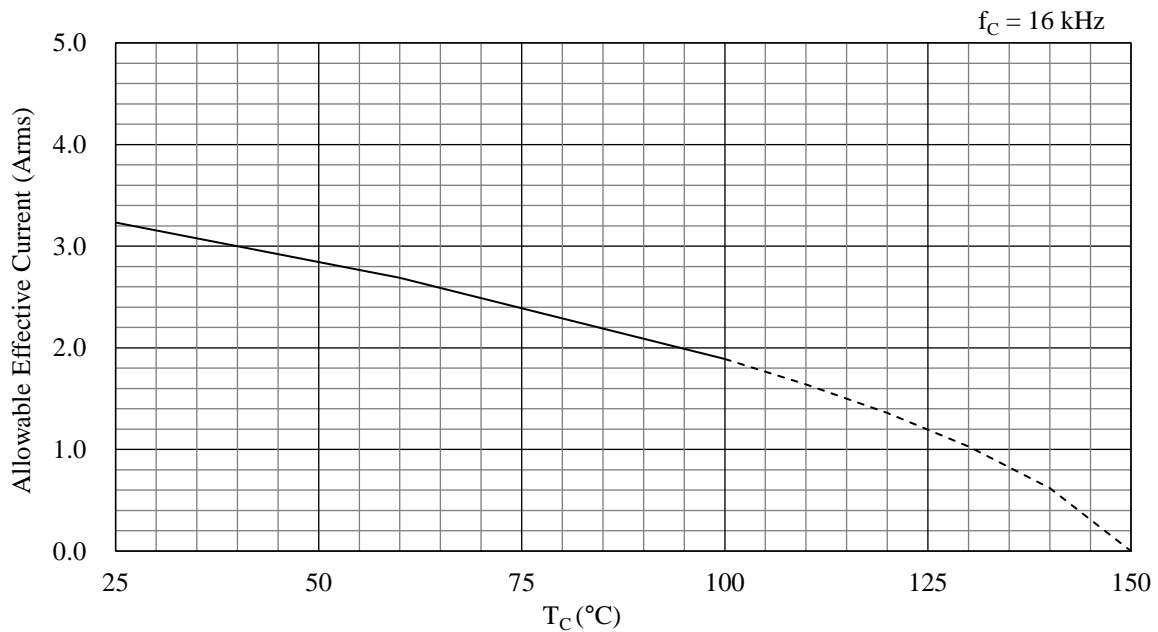

Figure 15-53. Allowable Effective Current ($f_c = 16 \text{ kHz}$): SIM6893M

SIM689xM Series

15.4.4 SIM6896M

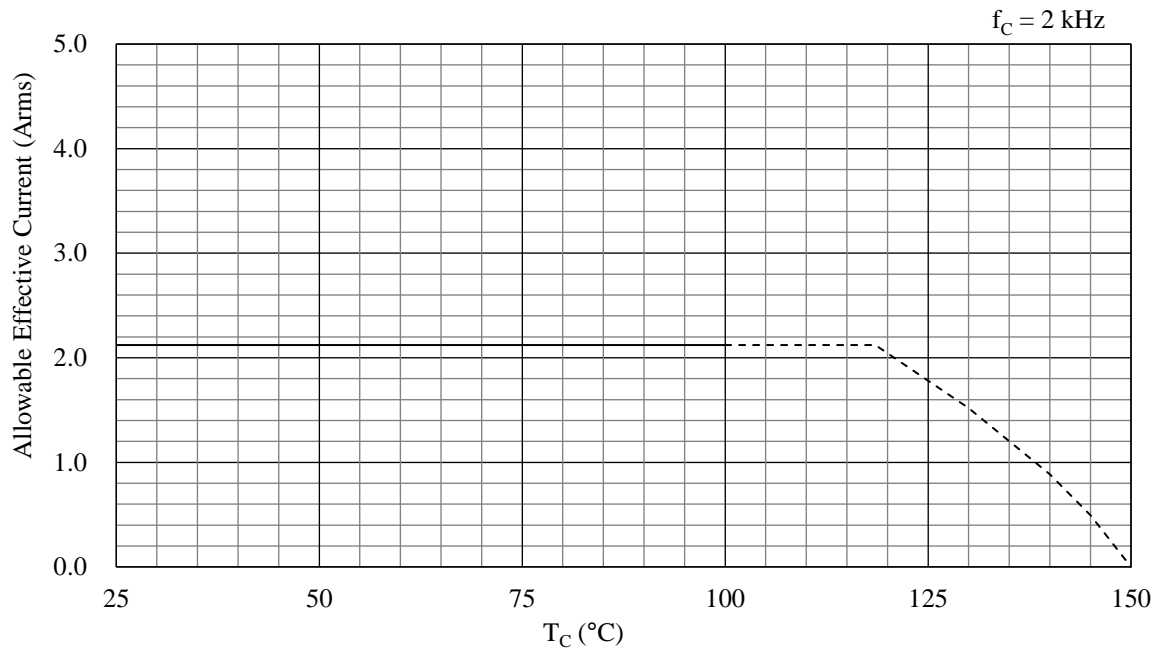

Figure 15-54. Allowable Effective Current ($f_c = 2 \text{ kHz}$): SIM6896M

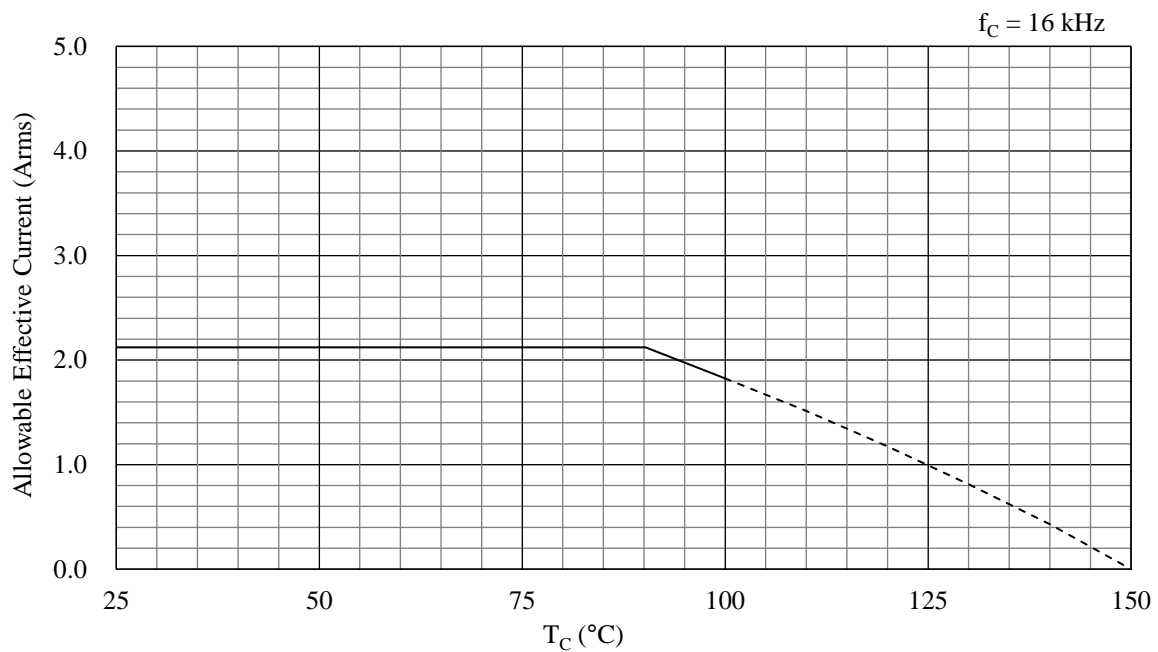

Figure 15-55. Allowable Effective Current ($f_c = 16 \text{ kHz}$): SIM6896M

SIM689xM Series

15.4.5 SIM6892M

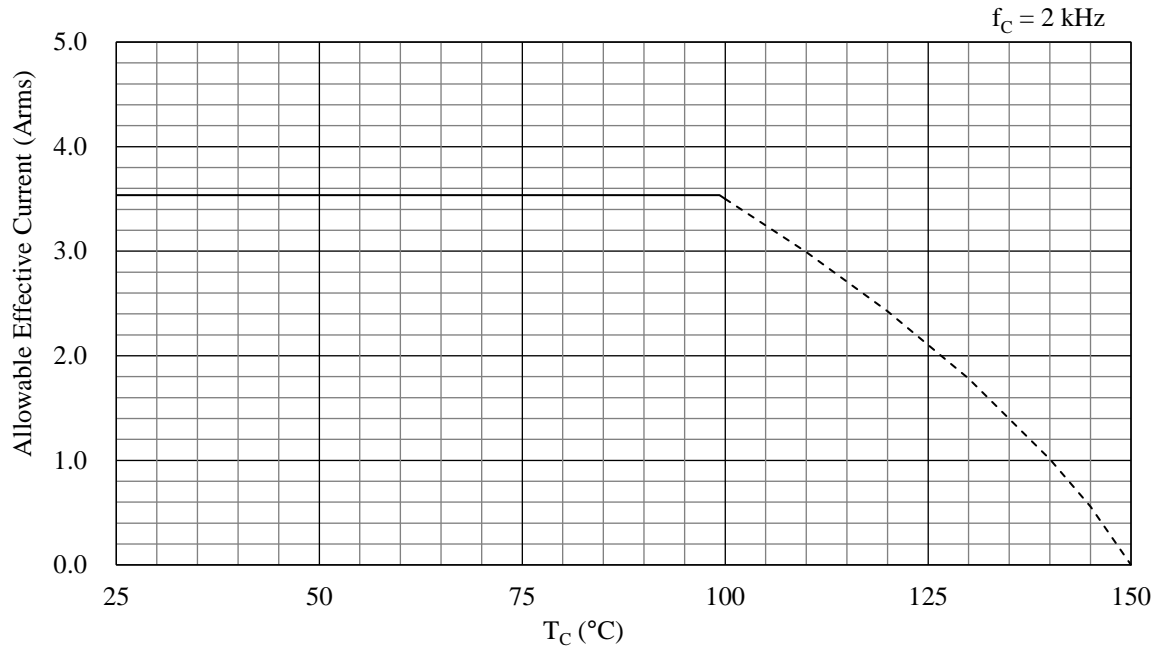

Figure 15-56. Allowable Effective Current ($f_c = 2 \text{ kHz}$): SIM6892M

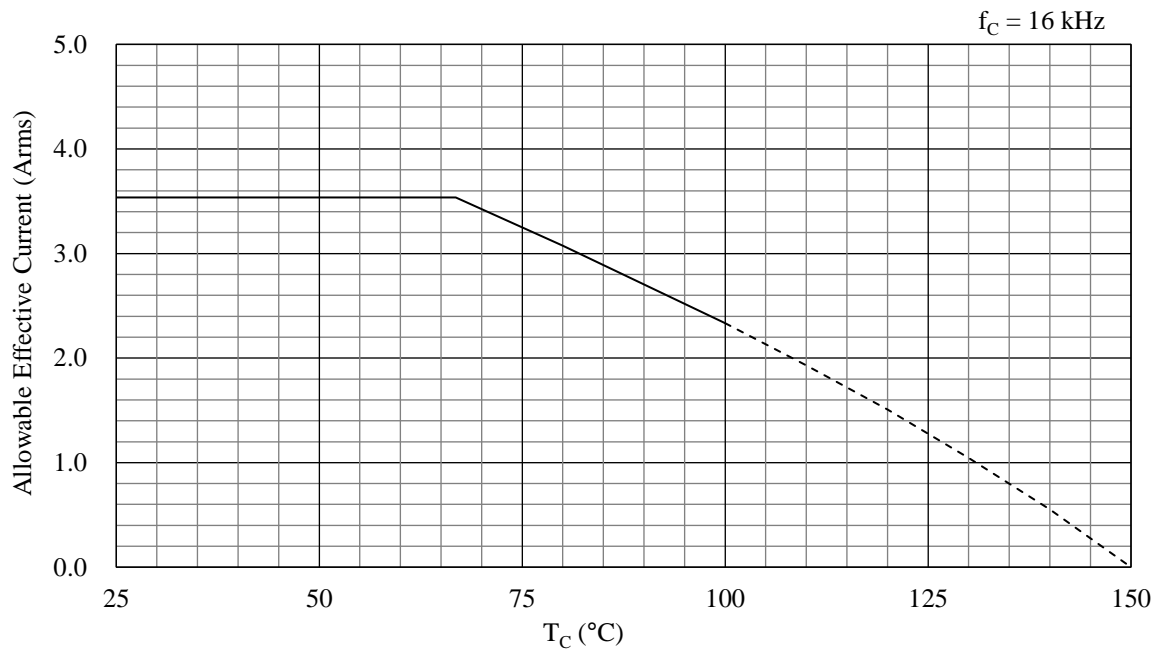

Figure 15-57. Allowable Effective Current ($f_c = 16 \text{ kHz}$): SIM6892M

SIM689xM Series

15.4.6 SIM6895M

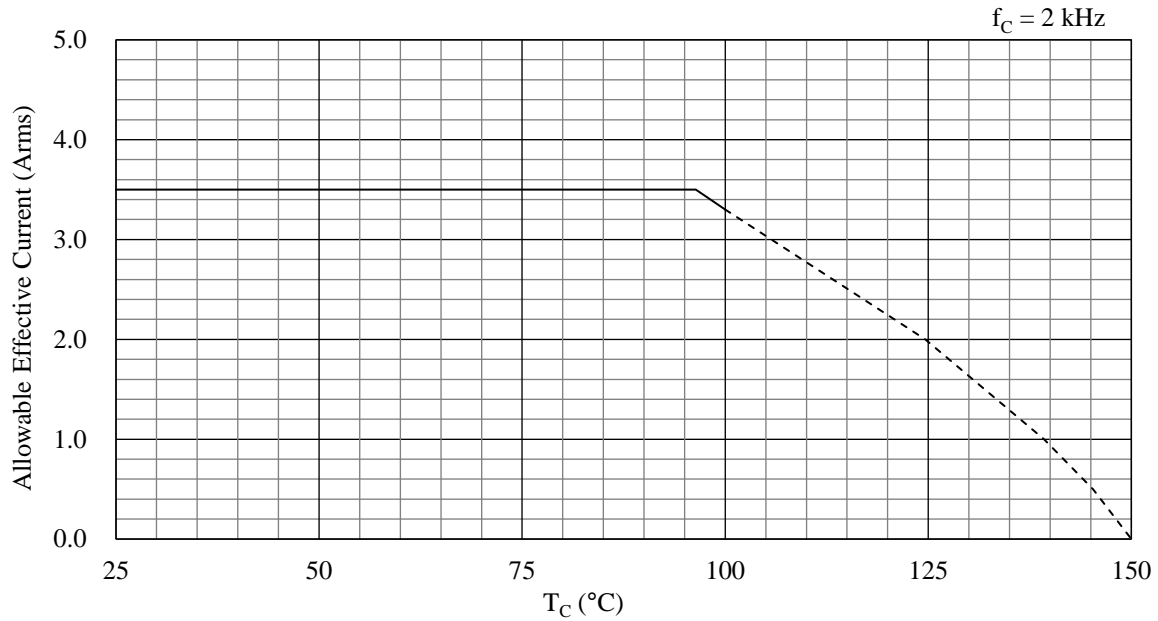

Figure 15-58. Allowable Effective Current ($f_c = 2 \text{ kHz}$): SIM6895M

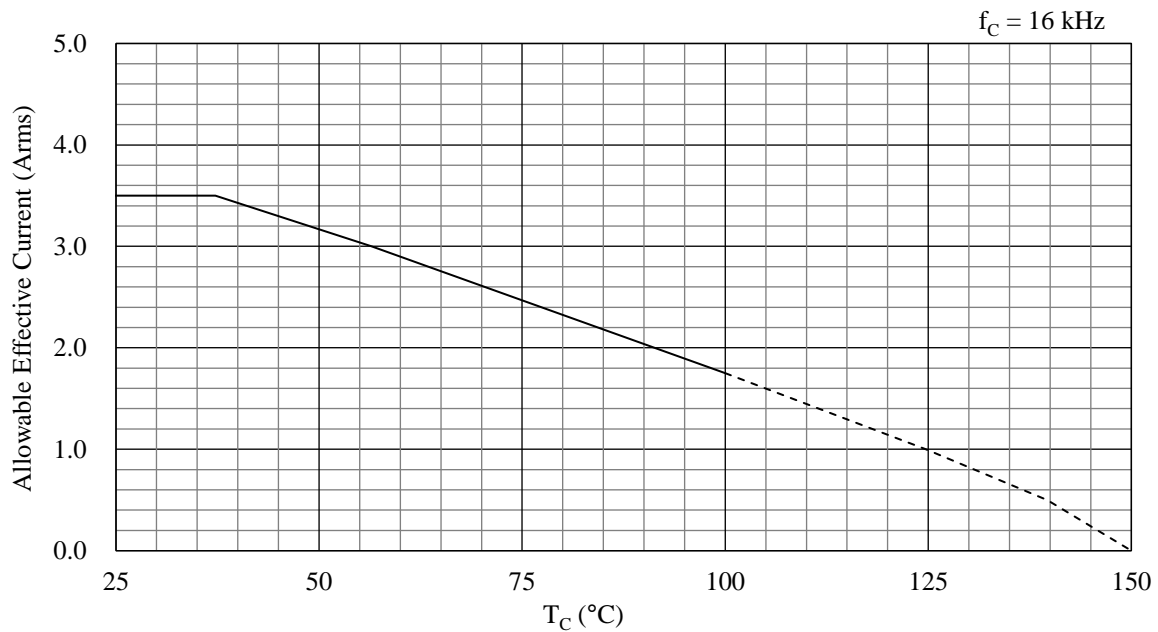

Figure 15-59. Allowable Effective Current ($f_c = 16 \text{ kHz}$): SIM6895M

SIM689xM Series

15.5 Short Circuit SOAs (Safe Operating Areas)

This section provides the graphs illustrating the short circuit SOAs of the SIM689xM series devices whose output transistors consist of built-in IGBTs.

Conditions: $V_{DC} \leq 400 \text{ V}$, $13.5 \text{ V} \leq V_{CC} \leq 16.5 \text{ V}$, $T_J = 125 \text{ }^\circ\text{C}$, 1 pulse.

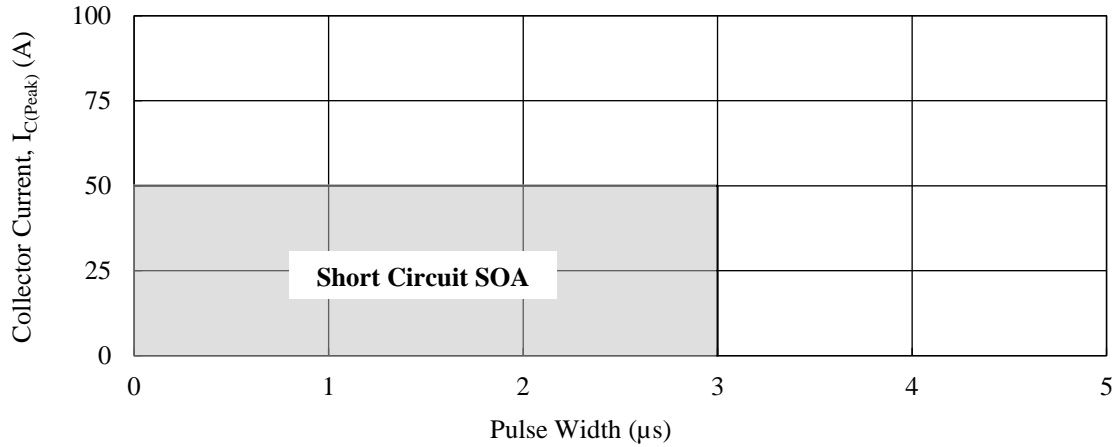

Figure 15-60. Short Circuit SOA: SIM6892M/SIM6895M

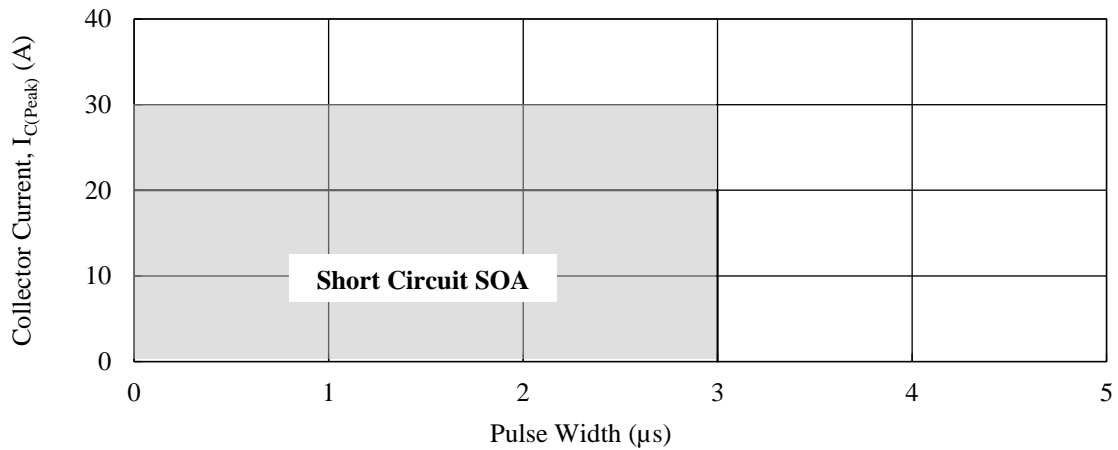
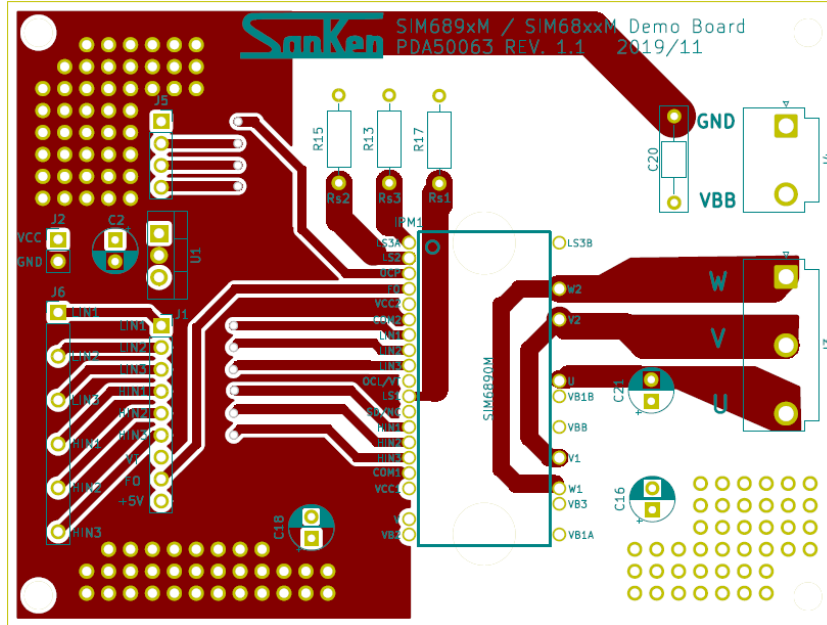

Figure 15-61. Short Circuit SOA: SIM6896M

SIM689xM Series

16. Pattern Layout Example

This section contains the schematic diagrams of a PCB pattern layout example using an SIM689xM series device. Note that the pattern layout example only uses the parts illustrated in the circuit diagram below. For more details on through holes, see Section 10.



(Top View)

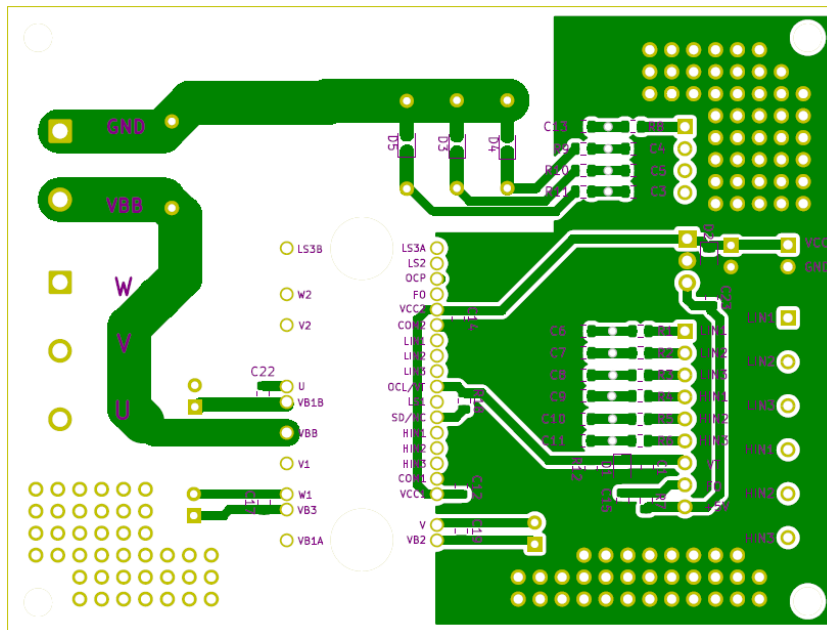

(Bottom View)

Figure 16-1. Pattern Layout Example

SIM689xM Series

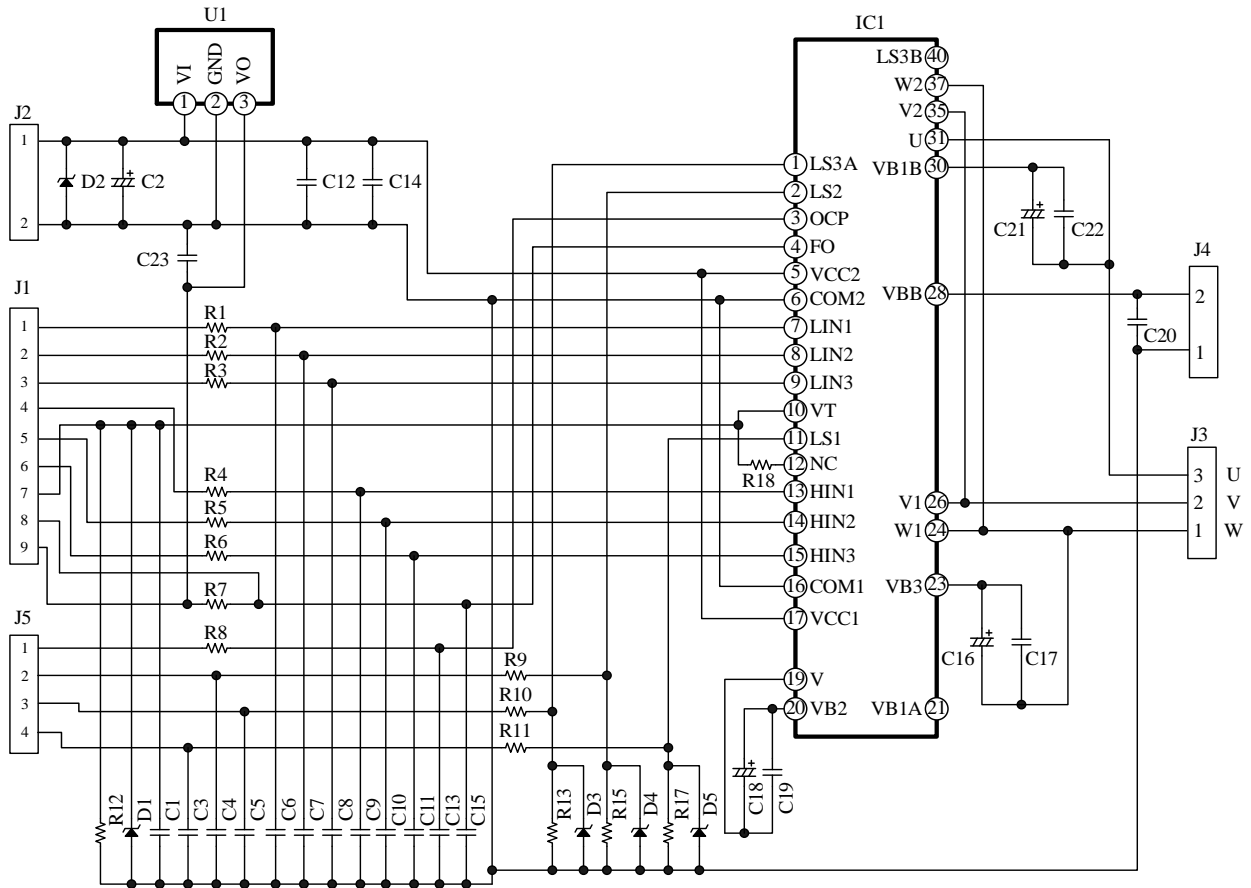

Figure 16-2. Circuit Diagram of PCB Pattern Layout Example

SIM689xM Series

17. Typical Motor Driver Application

This section contains the information on the typical motor driver application listed in the previous section, including a circuit diagram, specifications, and the bill of the materials used.

- **Motor Driver Specifications**

IC	SIM6892M
Main Supply Voltage, V_{DC}	300 VDC (typ.)
Rated Output Power	500 W

- **Circuit Diagram**

See Figure 16-2.

- **Bill of Materials**

Symbol	Part Type	Ratings	Symbol	Part Type	Ratings
C1	Ceramic	0.01 μ F, 50 V	R3	General	100 Ω , 1/8 W
C2	Electrolytic	100 μ F, 50 V	R4	General	100 Ω , 1/8 W
C3	Ceramic	100 pF, 50 V	R5	General	100 Ω , 1/8 W
C4	Ceramic	100 pF, 50 V	R6	General	100 Ω , 1/8 W
C5	Ceramic	100 pF, 50 V	R7	General	3.3 k Ω , 1/8 W
C6	Ceramic	100 pF, 50 V	R8	General	100 Ω , 1/8 W
C7	Ceramic	100 pF, 50 V	R9	General	100 Ω , 1/8 W
C8	Ceramic	100 pF, 50 V	R10	General	100 Ω , 1/8 W
C9	Ceramic	100 pF, 50 V	R11	General	100 Ω , 1/8 W
C10	Ceramic	100 pF, 50 V	R12	General	100 k Ω , 1/8 W
C11	Ceramic	100 pF, 50 V	R13*	Metal plate	72 m Ω , 2 W
C12	Ceramic	0.1 μ F, 50 V	R15*	Metal plate	72 m Ω , 2 W
C13	Ceramic	2200 pF, 50 V	R17*	Metal plate	72 m Ω , 2 W
C14	Ceramic	0.1 μ F, 50 V	R18	General	Open
C15	Ceramic	0.01 μ F, 50 V	D1	Zener diode	$V_z = 7$ V
C16	Electrolytic	47 μ F, 50 V	D2	Zener diode	$V_z = 20$ V
C17	Ceramic	100 pF, 50 V	D3	Zener diode	1A, 50 V
C18	Electrolytic	47 μ F, 50 V	D4	Zener diode	1A, 50 V
C19	Ceramic	100 pF, 50 V	D5	Zener diode	1A, 50 V
C20	Film	0.033 μ F, 630 V	J1	Connector	Equiv. to MA09-1
C21	Electrolytic	47 μ F, 50 V	J2	Connector	Equiv. to MA02-1
C22	Ceramic	100 pF, 50 V	J3	Pin header	Equiv. to B2P5-VH
C23	Ceramic	100 nF, 50 V	J4	Pin header	Equiv. to B2P3-VH
R1	General	100 Ω , 1/8 W	J5	Connector	Equiv. to MA04-1
R2	General	100 Ω , 1/8 W	IC1	IC	SIM6892M
			U1	IC	LM7805

* Refers to a part that requires adjustment based on operation performance in an actual application.

SIM689xM Series

Important Notes

- All data, illustrations, graphs, tables and any other information included in this document (the “Information”) as to Sanken’s products listed herein (the “Sanken Products”) are current as of the date this document is issued. The Information is subject to any change without notice due to improvement of the Sanken Products, etc. Please make sure to confirm with a Sanken sales representative that the contents set forth in this document reflect the latest revisions before use.
- The Sanken Products are intended for use as components of general purpose electronic equipment or apparatus (such as home appliances, office equipment, telecommunication equipment, measuring equipment, etc.). Prior to use of the Sanken Products, please put your signature, or affix your name and seal, on the specification documents of the Sanken Products and return them to Sanken. When considering use of the Sanken Products for any applications that require higher reliability (such as transportation equipment and its control systems, traffic signal control systems or equipment, disaster/crime alarm systems, various safety devices, etc.), you must contact a Sanken sales representative to discuss the suitability of such use and put your signature, or affix your name and seal, on the specification documents of the Sanken Products and return them to Sanken, prior to the use of the Sanken Products. The Sanken Products are not intended for use in any applications that require extremely high reliability such as: aerospace equipment; nuclear power control systems; and medical equipment or systems, whose failure or malfunction may result in death or serious injury to people, i.e., medical devices in Class III or a higher class as defined by relevant laws of Japan (collectively, the “Specific Applications”). Sanken assumes no liability or responsibility whatsoever for any and all damages and losses that may be suffered by you, users or any third party, resulting from the use of the Sanken Products in the Specific Applications or in manner not in compliance with the instructions set forth herein.
- In the event of using the Sanken Products by either (i) combining other products or materials or both therewith or (ii) physically, chemically or otherwise processing or treating or both the same, you must duly consider all possible risks that may result from all such uses in advance and proceed therewith at your own responsibility.
- Although Sanken is making efforts to enhance the quality and reliability of its products, it is impossible to completely avoid the occurrence of any failure or defect or both in semiconductor products at a certain rate. You must take, at your own responsibility, preventative measures including using a sufficient safety design and confirming safety of any equipment or systems in/for which the Sanken Products are used, upon due consideration of a failure occurrence rate and derating, etc., in order not to cause any human injury or death, fire accident or social harm which may result from any failure or malfunction of the Sanken Products. Please refer to the relevant specification documents and Sanken’s official website in relation to derating.
- No anti-radioactive ray design has been adopted for the Sanken Products.
- The circuit constant, operation examples, circuit examples, pattern layout examples, design examples, recommended examples, all information and evaluation results based thereon, etc., described in this document are presented for the sole purpose of reference of use of the Sanken Products.
- Sanken assumes no responsibility whatsoever for any and all damages and losses that may be suffered by you, users or any third party, or any possible infringement of any and all property rights including intellectual property rights and any other rights of you, users or any third party, resulting from the Information.
- No information in this document can be transcribed or copied or both without Sanken’s prior written consent.
- Regarding the Information, no license, express, implied or otherwise, is granted hereby under any intellectual property rights and any other rights of Sanken.
- Unless otherwise agreed in writing between Sanken and you, Sanken makes no warranty of any kind, whether express or implied, including, without limitation, any warranty (i) as to the quality or performance of the Sanken Products (such as implied warranty of merchantability, and implied warranty of fitness for a particular purpose or special environment), (ii) that any Sanken Product is delivered free of claims of third parties by way of infringement or the like, (iii) that may arise from course of performance, course of dealing or usage of trade, and (iv) as to the Information (including its accuracy, usefulness, and reliability).
- In the event of using the Sanken Products, you must use the same after carefully examining all applicable environmental laws and regulations that regulate the inclusion or use or both of any particular controlled substances, including, but not limited to, the EU RoHS Directive, so as to be in strict compliance with such applicable laws and regulations.
- You must not use the Sanken Products or the Information for the purpose of any military applications or use, including but not limited to the development of weapons of mass destruction. In the event of exporting the Sanken Products or the Information, or providing them for non-residents, you must comply with all applicable export control laws and regulations in each country including the U.S. Export Administration Regulations (EAR) and the Foreign Exchange and Foreign Trade Act of Japan, and follow the procedures required by such applicable laws and regulations.
- Sanken assumes no responsibility for any troubles, which may occur during the transportation of the Sanken Products including the falling thereof, out of Sanken’s distribution network.
- Although Sanken has prepared this document with its due care to pursue the accuracy thereof, Sanken does not warrant that it is error free and Sanken assumes no liability whatsoever for any and all damages and losses which may be suffered by you resulting from any possible errors or omissions in connection with the Information.
- Please refer to our official website in relation to general instructions and directions for using the Sanken Products, and refer to the relevant specification documents in relation to particular precautions when using the Sanken Products.
- All rights and title in and to any specific trademark or tradename belong to Sanken and such original right holder(s).

DSGN-CEZ-16003

OUR CERTIFICATE

DiGi provide top-quality products and perfect service for customer worldwide through standardization, technological innovation and continuous improvement. DiGi through third-party certification, we stricly control the quality of products and services. Welcome your RFQ to

Email: Info@DiGi-Electronics.com



Tel: +00 852-30501935

RFQ Email: Info@DiGi-Electronics.com

DiGi is a global authorized distributor of electronic components.