

SLA6868MZ-LF2175 Datasheet

www.digi-electronics.com

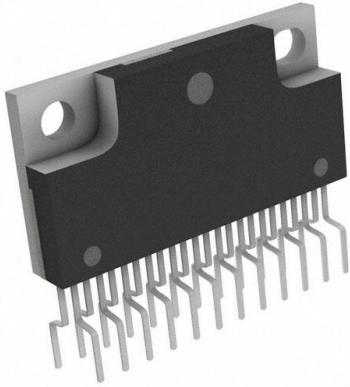

<https://www.DiGi-Electronics.com>

DiGi Electronics Part Number	SLA6868MZ-LF2175-DG
Manufacturer	Sanken Electric USA Inc.
Manufacturer Product Number	SLA6868MZ-LF2175
Description	IC BRIDGE DRIVER PAR 24SIP
Detailed Description	Motor Driver Power MOSFET Logic 24-ZIP LF2175

This model SLA6868MZ-LF2175 is available at DiGi Electronics.

DiGi Electronics offers a global database of semiconductor and electronic component datasheets.

We welcome your inquiries regarding pricing, lead time, or other product-related questions.

 [Request a Quote](#)

 [Datasheet Search](#)



Tel: +00 852-30501935

RFQ Email: Info@DiGi-Electronics.com

DiGi is a global authorized distributor of electronic components.

Purchase and inquiry

Manufacturer Product Number:

SLA6868MZ-LF2175

Series:

-

Motor Type - Stepper:

-

Function:

Driver

Interface:

Logic

Step Resolution:

-

Current - Output:

2.5A

Voltage - Load:

500V (Max)

Mounting Type:

Through Hole

Supplier Device Package:

24-ZIP LF2175

Manufacturer:

Sanken Electric USA Inc.

Product Status:

Obsolete

Motor Type - AC, DC:

Brushless DC (BLDC)

Output Configuration:

Half Bridge (3)

Technology:

Power MOSFET

Applications:

Home Appliance

Voltage - Supply:

13.5V ~ 16.5V

Operating Temperature:

-20°C ~ 150°C (TJ)

Package / Case:

24-SSIP Exposed Pad, Formed Leads

Base Product Number:

SLA6868

Environmental & Export classification

RoHS Status:

RoHS Compliant

ECCN:

EAR99

Moisture Sensitivity Level (MSL):

1 (Unlimited)

HTSUS:

8542.39.0001



SLA6868MZ and SLA6870MZ

High Voltage 3-Phase Motor Drivers

Features and Benefits

- Built-in pre-drive IC
- MOSFET power element
- Alleviate noise generation by adjusting an internal resistor
- CMOS compatible input (5 V)
- High-side gate driver using bootstrap circuit or floating power supply
- Built-in protection circuit for controlling power supply voltage drop (UVLO on VCC)
- Overcurrent protection (OCP), overcurrent limiting (OCL), and thermal shutdown (TSD)
- Output of fault signal during operation of protection circuit
- Output current 1.5, 2.5, or 3 A
- Small SIP (SLA 24-pin)

Packages: Power SIP

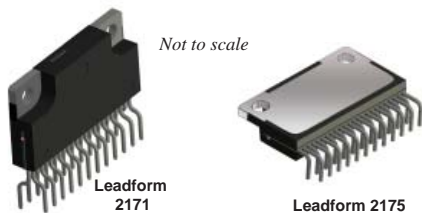

Description

The SLA6868MZ and SLA6870MZ inverter power module (IPM) ICs provide a robust, highly-integrated solution for optimally controlling 3-phase motor power inverter systems and variable speed control systems used in energy-conserving designs to drive motors of residential and commercial appliances. These ICs take 230 VAC input voltage, and up to 3 A (continuous) output current. They can withstand voltages of up to 500 V (MOSFET breakdown voltage).

The SLA power package includes an IC with all of the necessary power elements (six MOSFETs), pre-driver ICs (two), and bootstrap diodes (three), needed to configure the main circuit of an inverter. This enables the main circuit of the inverter to be configured with fewer external components than traditional designs.

Applications include residential white goods (home applications) and commercial appliance motor control:

- Air conditioner fan
- Small ventilation fan
- Dishwasher pump

Functional Block Diagram

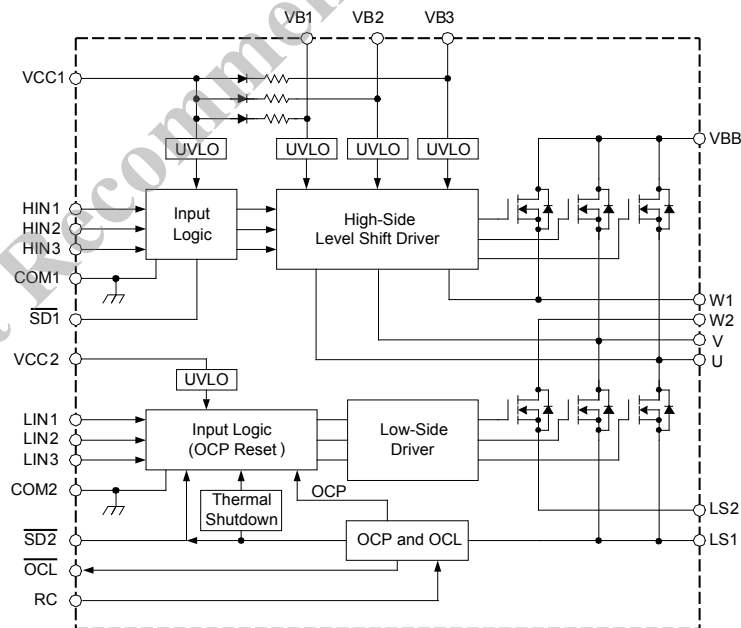

A. $\overline{SD1}$, $\overline{SD2}$ terminals are used for both input and output.

B. $\overline{SD1}$, $\overline{SD2}$, and \overline{OCL} terminals are open-collector output. RC terminal is open-drain input.

C. Blanking Time (t_{blank}) is used in Overcurrent Limiting (OCL) and Overcurrent Protection (OCP).

If the time exceeds the limit, the signal will be output (open-collector output turns on), and protection operation will start up.

Figure 1. Driver block diagram.

**SLA6868MZ and
SLA6870MZ**

High Voltage 3-Phase Motor Drivers

Selection Guide

Part Number	MOSFET Breakdown Voltage, $V_{DSS}(\text{min})$ (V)	Output Current	
		Continuous, $I_o(\text{max})$ (A)	Pulsed, $I_{OP}(\text{max})$ (A)
SLA6868MZ	500	2.5	3.75
SLA6870MZ	500	3	4.5

Absolute Maximum Ratings, valid at $T_A = 25^\circ\text{C}$

Characteristic	Symbol	Remarks	Rating	Unit
MOSFET Breakdown Voltage	V_{DSS}	$V_{CC} = 15\text{ V}$, $I_D = 100\ \mu\text{A}$, $V_{IN} = 0\text{ V}$	500	V
Logic Supply Voltage	V_{CC}	Between VCC and COM	20	V
Bootstrap Voltage	V_{BS}	Between VB and HS (U,V, and W phases)	20	V
Output Current, Continuous	I_o	SLA6868MZ	2.5	A
		SLA6870MZ	3	A
Output Current, Pulsed	I_{OP}	SLA6868MZ	3.75	A
		SLA6870MZ	4.5	A
Input Voltage	V_{IN}	HINx and LINx pins	-0.5 to 7	V
Pull-up Voltage for Shutdown Pins	V_{SDX}	SDx pins	7	V
Pull-up Voltage for Overcurrent Limiting Pin	V_{OCL}		7	V
Allowable Power Dissipation	P_D	$T_C = 25^\circ\text{C}$	32.9	W
Thermal Resistance (Junction to Case)	$R_{\theta JC}$	All elements operating	3.8	$^\circ\text{C}/\text{W}$
Case Operating Temperature	T_{COP}		-20 to 100	$^\circ\text{C}$
Junction Temperature (MOSFET)	T_J		150	$^\circ\text{C}$
Storage Temperature	T_{stg}		-40 to 150	$^\circ\text{C}$

All performance characteristics given are typical values for circuit or system baseline design only and are at the nominal operating voltage and an ambient temperature, T_A , of 25°C , unless otherwise stated.

**SLA6868MZ and
SLA6870MZ**

High Voltage 3-Phase Motor Drivers

Recommended Operating Conditions

Characteristic	Symbol	Remarks	Min.	Typ.	Max.	Units
Main Supply Voltage	V_{BB}	Between V_{BB} and LS	–	–	400	V
V_{BB} Snubber Capacitor	C_{SB}		0.01	–	0.1	μF
Logic Supply Voltage	V_{CC}	Between VCC and COM	13.5	15	16.5	V
Zener Voltage for VCCx Pins	V_Z	Between VCC and COM	18	–	20	V
Pull-up Voltage	V_{SDx}, V_{OCL}		4.5	5	5.5	V
Pull-up Resistor \overline{SDx} Pins	R_{UP2}		3.3	–	10	$\text{k}\Omega$
Pull-up Resistor OCL Pin	R_{UP1}		1	–	10	$\text{k}\Omega$
Pull-up Resistor RC Pin	R_R		33	–	390	$\text{k}\Omega$
Capacitor \overline{SDx} Pins	C_{SDX}		1	–	10	nF
Capacitor RC Pin	C_C		1	–	4.7	nF
Dead Time	t_{dead}	$T_J = -20^\circ\text{C}$ to 150°C	1.5	–	–	μs
Minimum Input Pulse Width	$I_{INMIN(on)}$	$T_J = -20^\circ\text{C}$ to 150°C	0.5	–	–	μs
	$I_{INMIN(off)}$	$T_J = -20^\circ\text{C}$ to 150°C	0.5	–	–	μs
Switching Frequency	f_{PWM}		–	–	20	kHz

SLA6868MZ and SLA6870MZ

High Voltage 3-Phase Motor Drivers

Typical Application Diagram

Shows configuration for implementing current limiter function: OCL and SD1 pins tied together

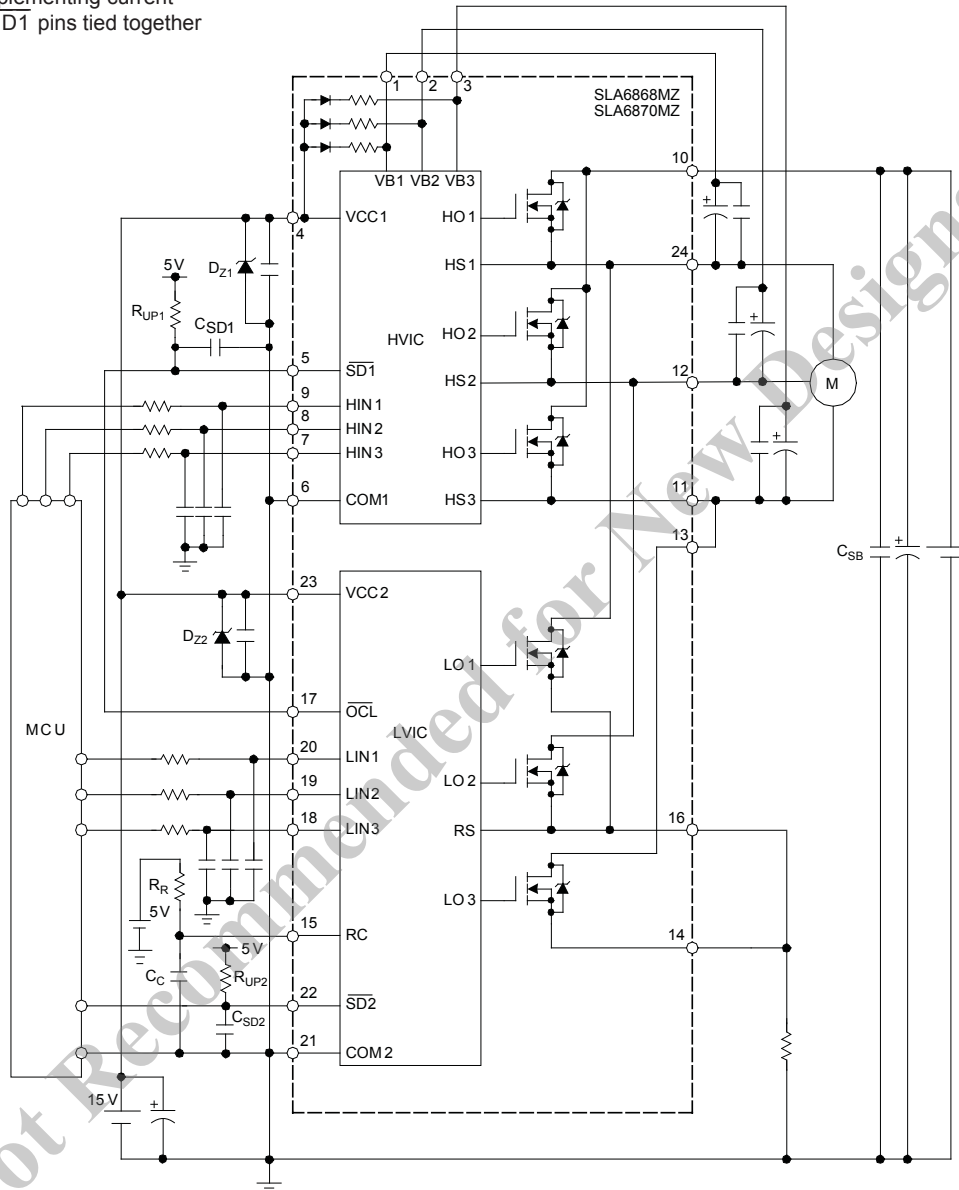

NOTE:

- The external electrolytic capacitors should be placed as close to the IC as possible, in order to avoid malfunctions from external noise interference. Put a ceramic capacitor in parallel with the electrolytic capacitor if further reduction of noise susceptibility is necessary.

SLA6868MZ and SLA6870MZ

High Voltage 3-Phase Motor Drivers

Typical Application Diagram

Shows configuration without current limiter
function: SD1 and SD2 pins tied together

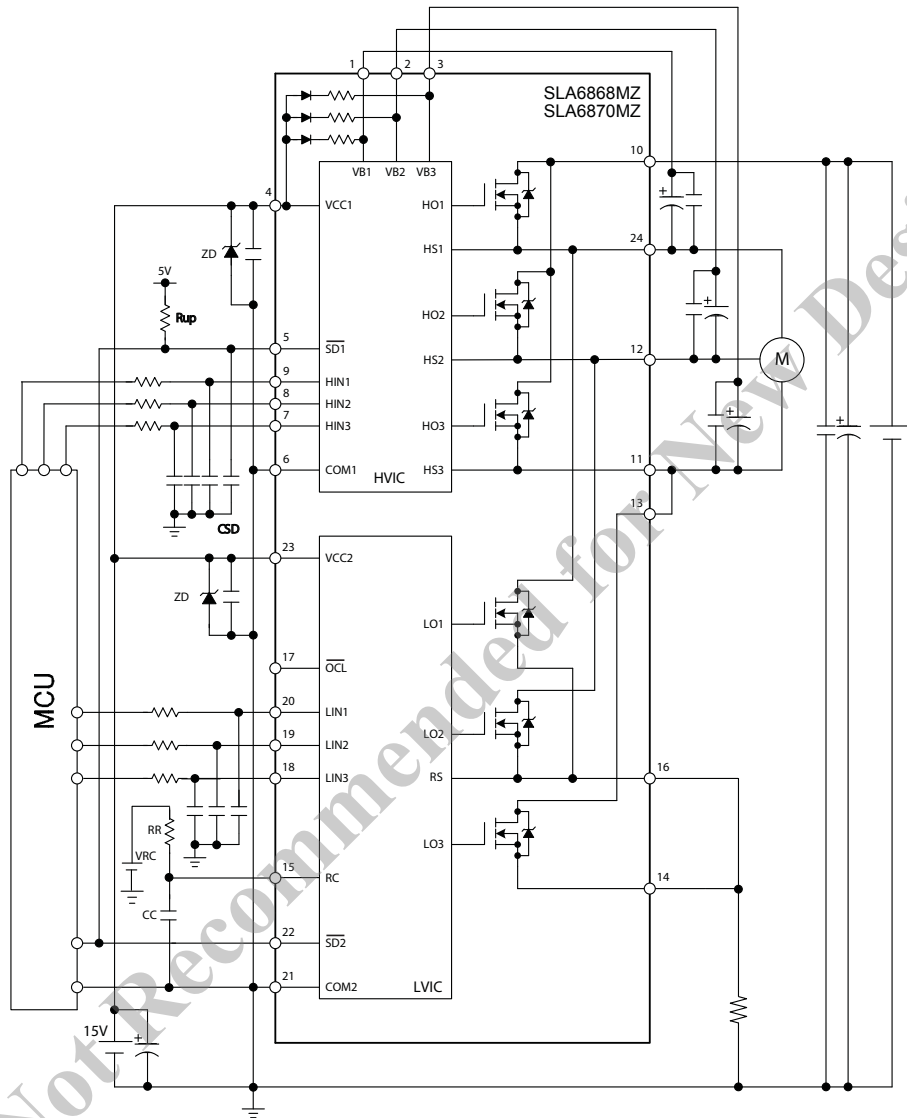

NOTE:

The external electrolytic capacitors should be placed as close to the IC as possible, in order to avoid malfunctions from external noise interference. Put a ceramic capacitor in parallel with the electrolytic capacitor if further reduction of noise susceptibility is necessary.

**SLA6868MZ and
SLA6870MZ**

High Voltage 3-Phase Motor Drivers

ELECTRICAL CHARACTERISTICS, valid at $T_A=25^\circ\text{C}$, unless otherwise noted

Characteristics	Symbol	Conditions	Min	Typ	Max	Units
Logic Supply Current	I_{CC}	SLA6868MZ	-	4.2	7	mA
		SLA6870MZ		2.7	5.0	
Bootstrap Supply Current	I_{BX}	$V_{BX} = 15\text{ V}$, $V_{HIN} = 5\text{ V}$	-	135	380	μA
Input Voltage	V_{IH}	$V_{CC} = 15\text{ V}$	-	2.9	3.4	V
	V_{IL}	$V_{CC} = 15\text{ V}$	1.6	2.1	-	V
Input Voltage Hysteresis	V_{Ihys}	$V_{CC} = 15\text{ V}$	-	0.8	-	V
Input Current	I_{IN}	$V_{IN} = 5\text{ V}$	-	230	500	μA
Undervoltage Lock Out	V_{UVHL}	High side, between VBx and U, V, or W	9.0	10.0	11.0	V
	V_{UVHH}		9.5	10.5	11.5	V
	V_{UVHhys}	High side, hysteresis	-	0.5	-	V
	V_{UVLL}	Low side, between VCC2 and COM2	10.0	11.0	12.0	V
	V_{UVLH}		10.5	11.5	12.5	V
	V_{UVLhys}	Low side, hysteresis	-	0.5	-	V
SDx and OCL Output Voltage	$V_{SDX(on)}$, V_{OCL}	$V_{SDX} = V_{OCL} = 5\text{ V}$, $R_{UPX} = 3.3\text{ k}\Omega$	-	-	0.6	V
Overtemperature Detection Threshold Temperature (Activation and Deactivation)	T_{DH}	$V_{CC} = 15\text{ V}$, high-side and low side	120	135	150	$^\circ\text{C}$
	T_{DL}		100	115	130	$^\circ\text{C}$
	T_{Dhys}		-	20	-	$^\circ\text{C}$
Overcurrent Protection Trip Voltage	V_{TRIP}	$V_{CC} = 15\text{ V}$	0.9	1.0	1.1	V
Overcurrent Limit Reference Voltage	V_{LIM}	$V_{CC} = 15\text{ V}$	0.5035	0.53	0.5565	V
Overcurrent Protection Hold Time	t_p	$V_{RC} = 5\text{ V}$, $R_R = 360\text{ k}\Omega$, $C_C = 0.0047\text{ }\mu\text{F}$	-	2.0	-	ms
Blanking Time	t_{blank}	$V_{CC} = 15\text{ V}$	1.4	2.0	2.6	μs
Bootstrap Diode Leakage Current	I_{LBD}	$V_R = 250\text{ V}$	-	-	10	μA
Bootstrap Diode Forward Voltage	V_{FBD}	SLA6868MZ	-	1.1	1.3	V
		SLA6870MZ		0.8	1.3	
Bootstrap Diode Recovery Time	t_{rb}	$I_F / I_{RP} = 100\text{ mA} / 100\text{ mA}$	-	70	-	ns
Bootstrap Diode Series Resistor	R_{BD}		168	210	252	Ω
MOSFET Breakdown Voltage	V_{DSS}	$V_{CC} = 15\text{ V}$, $I_D = 100\text{ }\mu\text{A}$, $V_{IN} = 0\text{ V}$	500	-	-	V
MOSFET Leakage Current	I_{DSS}	$V_{CC} = 15\text{ V}$, $V_{DS} = 500\text{ V}$, $V_{IN} = 0\text{ V}$	-	-	100	μA
MOSFET On State Resistance	$R_{DS(on)}$	SLA6868MZ	-	2.0	2.4	Ω
		SLA6870MZ		1.4	1.7	
MOSFET Diode Forward Voltage	V_{SDF}	SLA6868MZ	-	1.1	1.5	V
		SLA6870MZ		1.0	1.5	

**SLA6868MZ and
SLA6870MZ**

High Voltage 3-Phase Motor Drivers

SLA6868MZ SWITCHING CHARACTERISTICS, valid at $T_A=25^\circ\text{C}$, unless otherwise noted

Characteristics	Symbol	Conditions	Min	Typ	Max	Units
Switching Time, High Side	$t_{dH(on)}$	$V_{BB} = 300\text{ V}, V_{CC} = 15\text{ V}, I_D = 2.5\text{ A}, 0\text{ V} \leq V_{IN} \leq 5\text{ V}$	-	790	-	ns
	t_{rH}		-	60	-	ns
	t_{rrH}		-	115	-	ns
	$t_{dH(off)}$		-	725	-	ns
	t_{fH}		-	20	-	ns
Switching Time, Low Side	$t_{dL(on)}$	$V_{BB} = 300\text{ V}, V_{CC} = 15\text{ V}, I_D = 2.5\text{ A}, 0\text{ V} \leq V_{IN} \leq 5\text{ V}$	-	680	-	ns
	t_{rL}		-	70	-	ns
	t_{rrL}		-	120	-	ns
	$t_{dL(off)}$		-	605	-	ns
	t_{fL}		-	20	-	ns

SLA6870MZ SWITCHING CHARACTERISTICS, valid at $T_A=25^\circ\text{C}$, unless otherwise noted

Characteristics	Symbol	Conditions	Min	Typ	Max	Units
Switching Time, High Side	$t_{dH(on)}$	$V_{BB} = 300\text{ V}, V_{CC} = 15\text{ V}, I_D = 2.5\text{ A}, 0\text{ V} \leq V_{IN} \leq 5\text{ V},$ inductive load	-	755	-	ns
	t_{rH}		-	65	-	ns
	t_{rrH}		-	100	-	ns
	$t_{dH(off)}$		-	680	-	ns
	t_{fH}		-	15	-	ns
Switching Time, Low Side	$t_{dL(on)}$	$V_{BB} = 300\text{ V}, V_{CC} = 15\text{ V}, I_D = 2.5\text{ A}, 0\text{ V} \leq V_{IN} \leq 5\text{ V},$ inductive load	-	645	-	ns
	t_{rL}		-	70	-	ns
	t_{rrL}		-	105	-	ns
	$t_{dL(off)}$		-	560	-	ns
	t_{fL}		-	20	-	ns

SLA6868MZ and
SLA6870MZ

High Voltage 3-Phase Motor Drivers

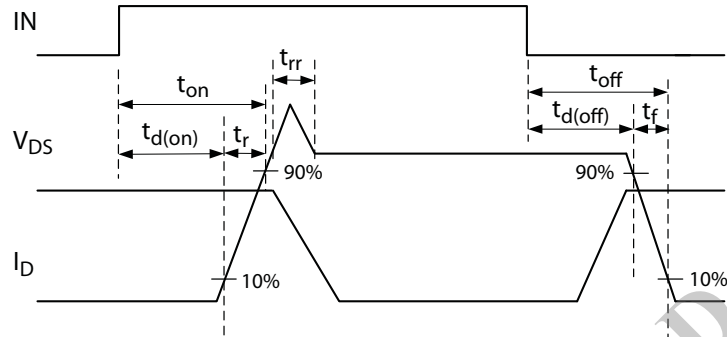

Switching Characteristics Definitions

Not Recommended for New Designs

Truth Table

Mode	Hin	Lin	H-side MOSFET	L-side MOSFET
Normal	L	L	Off	Off
	H	L	On	Off
	L	H	Off	On
	H	H	On	On
TSD	L	L	Off	Off
	H	L	On	Off
	L	H	Off	Off
	H	H	On	Off
OCP	L	L	Off	Off
	H	L	On	Off
	L	H	Off	Off
	H	H	On	Off
$\overline{\text{OCL}} (= L)^1$	L	L	Off	Off
	H	L	Off	Off
	L	H	Off	On
	H	H	Off	On
UVLO (VCC) ²	L	L	Off	Off
	H	L	Off	Off
	L	H	Off	Off
	H	H	Off	Off
UVLO (VB) ³	L	L	Off	Off
	H	L	Off	Off
	L	H	Off	On
	H	H	Off	On
$\overline{\text{SD2}} (= L)$	L	L	Off	Off
	H	L	On	Off
	L	H	Off	Off
	H	H	On	Off

¹The OCL feature is enabled when the $\overline{\text{OCL}}$ and $\overline{\text{SD1}}$ pins are tied together externally. If these pins are not tied when an OCL condition occurs, device operation continues in Normal mode.

²Returning to the Normal mode of operation from a V_{CC} UVLO condition, a high-side MOSFET resumes switching on the rising edge of an HINx input. On the other hand, a low-side MOSFET resumes switching on the first logic high of a LINx input after release of the UVLO condition.

³Returning to the Normal mode of operation from a V_B UVLO condition, a high-side MOSFET resumes switching on the rising edge of an HINx input.

Note: To prevent a shoot-through condition, the external microcontroller should not drive HINx = LINx = H at the same time.

OCP Timing Diagram

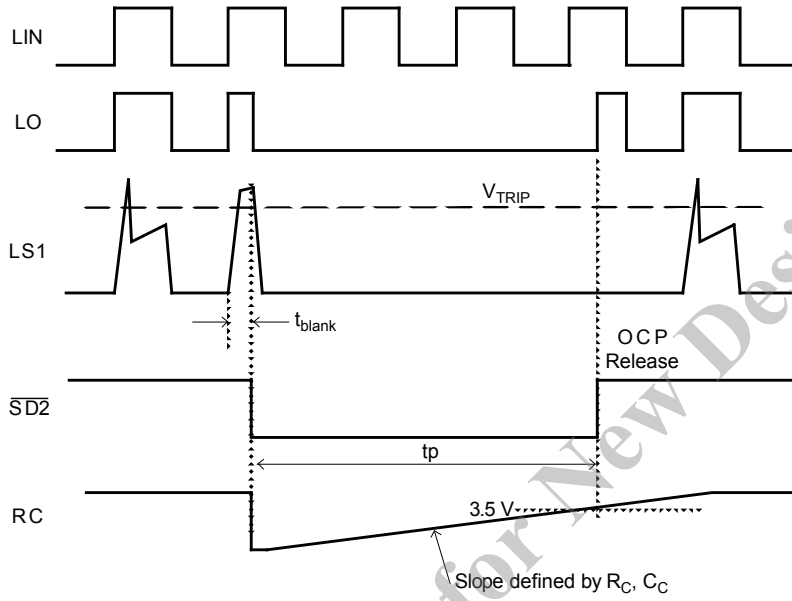

Low-Side TSD Timing Diagram

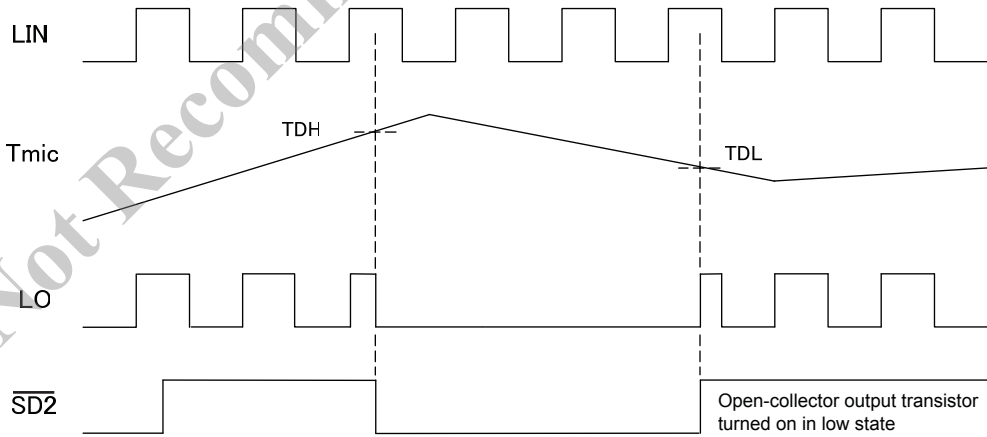

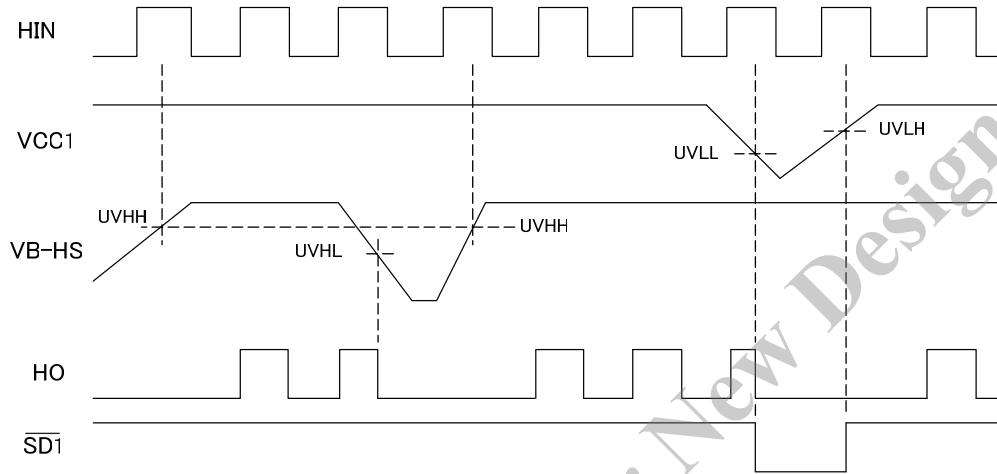
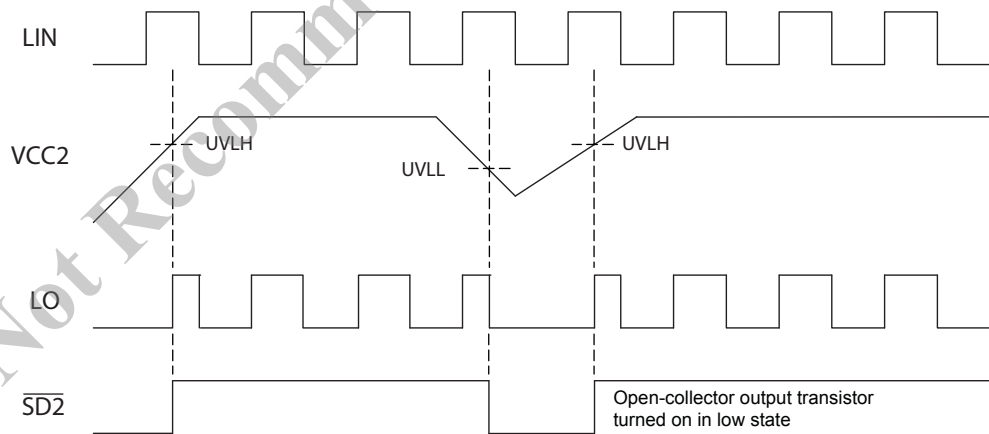
High-Side UVLO Timing Diagram**Low-Side UVLO Timing Diagram**

OCL Timing Diagram

$\overline{\text{OCL}}$ and $\overline{\text{SD1}}$ pins connected externally

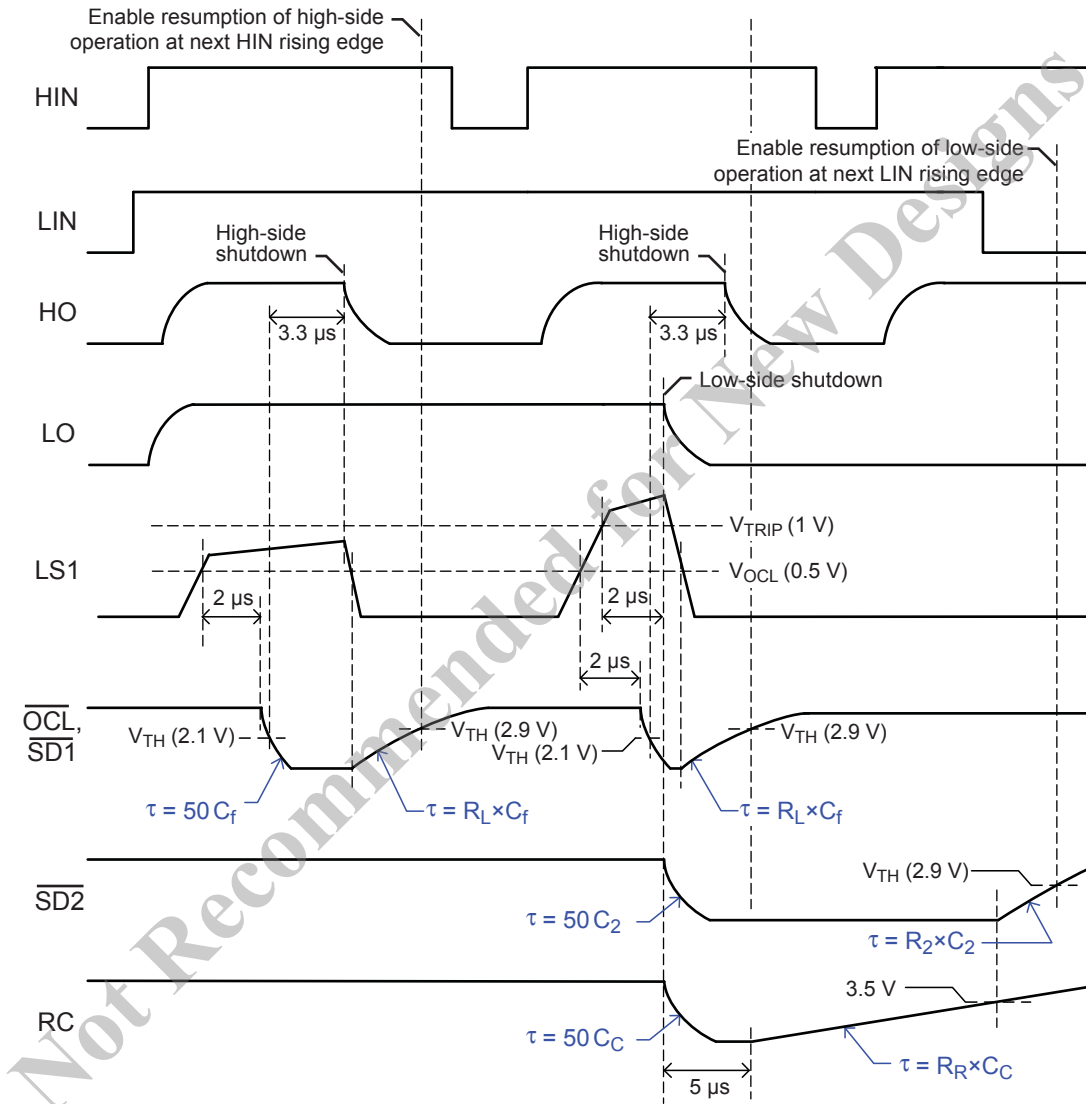

Shut Down Timing Diagram

$\overline{SD1}$ and $\overline{SD2}$ pins connected externally; current-limiter function not in use

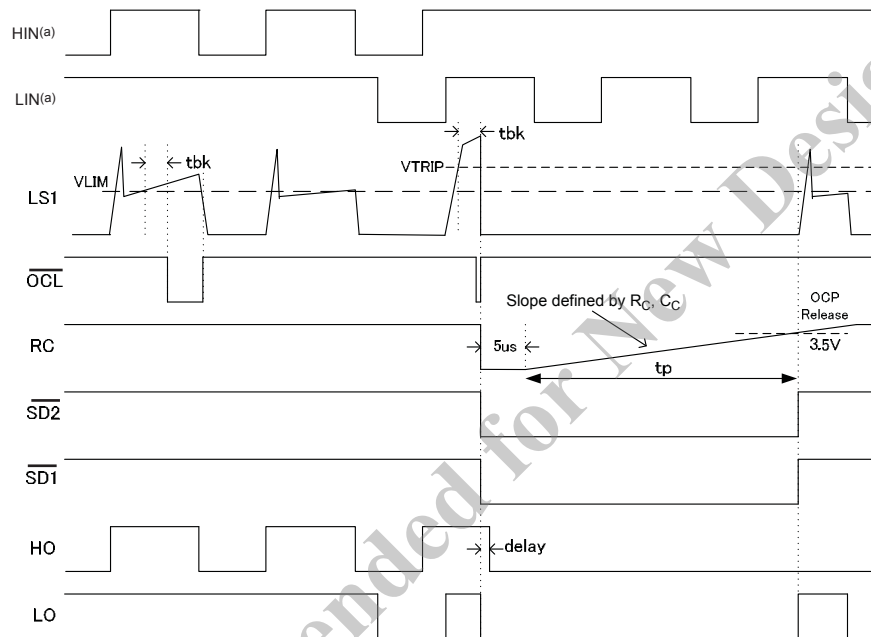

(a) Each HINx or LINx pin drives a independent side of a phase, that is, the high-side and the low-side switching devices of a U, V, or W motor coil phase are each driven separately, by the corresponding dedicated HINx or LINx input

**SLA6868MZ and
SLA6870MZ**

High Voltage 3-Phase Motor Drivers

Pin-out Diagram

Leadform 2171

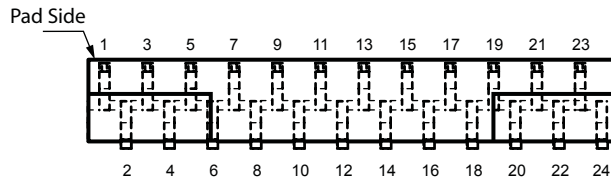

Leadform 2175

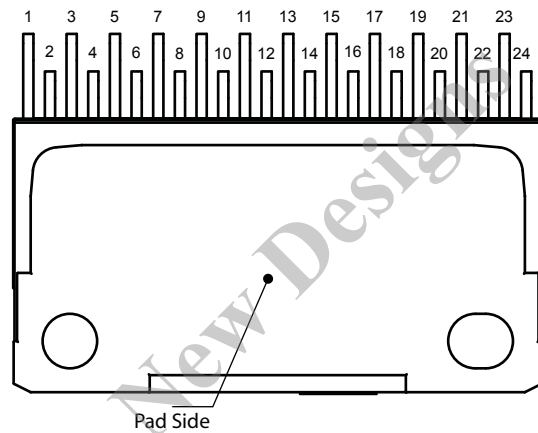
Terminal List Table

Number	Name	Function
1	VB1	High side bootstrap terminal (U phase)
2	VB2	High side bootstrap terminal (V phase)
3	VB3	High side bootstrap terminal (W phase)
4	VCC1	High side logic supply voltage
5	$\overline{SD1}$	High side shutdown input and UVLO fault signal output
6	COM1	High side logic GND terminal
7	HIN3	High side input terminal (W phase)
8	HIN2	High side input terminal (V phase)
9	HIN1	High side input terminal (U phase)
10	VBB	Main supply voltage
11	W1	Output of W phase (connect to W2 externally)
12	V	Output of V phase
13	W2	Output of W phase (connect to W1 externally)
14	LS2	Low side source terminal (connect to LS1 externally)
15	RC	Overcurrent protection hold time adjustment input terminal
16	LS1	Low side source terminal (connect to LS2 externally)
17	\overline{OCL}	Output for overcurrent limiting
18	LIN3	Low side input terminal (W phase)
19	LIN2	Low side input terminal (V phase)
20	LIN1	Low side input terminal (U phase)
21	COM2	Low side GND terminal
22	$\overline{SD2}$	Low side shutdown input and overtemperature, overcurrent, and UVLO fault signals output
23	VCC2	Low side logic supply voltage
24	U	Output of U phase

SLA6868MZ and
SLA6870MZ

High Voltage 3-Phase Motor Drivers

Package Outline Drawing Leadform 2171

Dual rows, 24 alternating pins; vertical case mounting; pin #1 on pad side

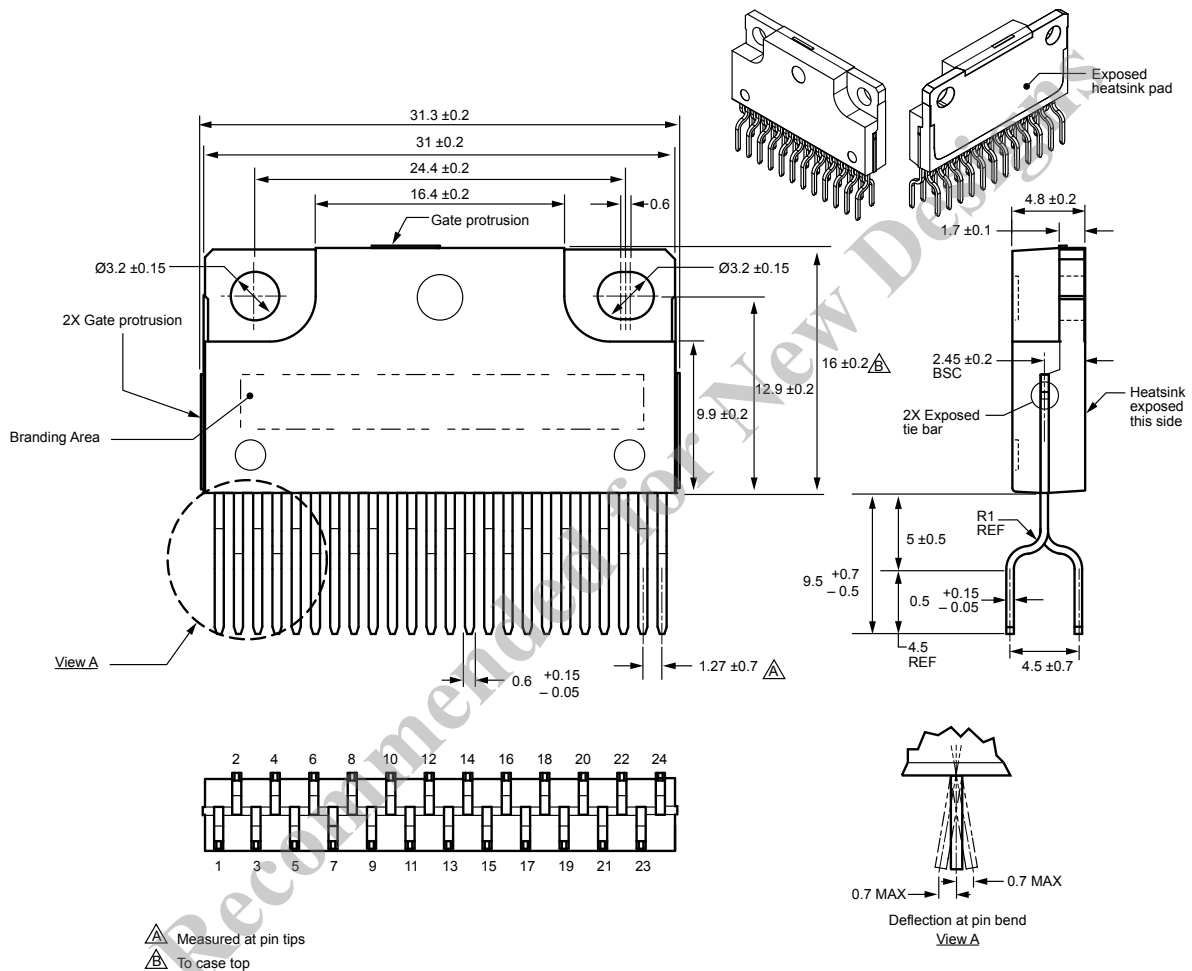

Leadform: 2171
Terminal core material: Cu
Terminal plating: Ni
Recommended attachment: Solder dip (Sn-Ag-Cu)

Dimensions in millimeters

Branding codes (exact appearance at manufacturer discretion):
1st line, type: SLA6868MZ or SLA6870MZ

2nd line, lot: YMDD#
Where: Y is the last digit of the year of manufacture
M is the month (1 to 9, O, N, D)
DD is the date
is the tracking letter



Leadframe plating Pb-free. Device composition
complies with the RoHS directive.

SLA6868MZ and
SLA6870MZ

High Voltage 3-Phase Motor Drivers

Package Outline Drawing Leadform 2175

Dual rows, 24 alternating pins; pins bent 90° for horizontal case mounting; pin #1 in outer row

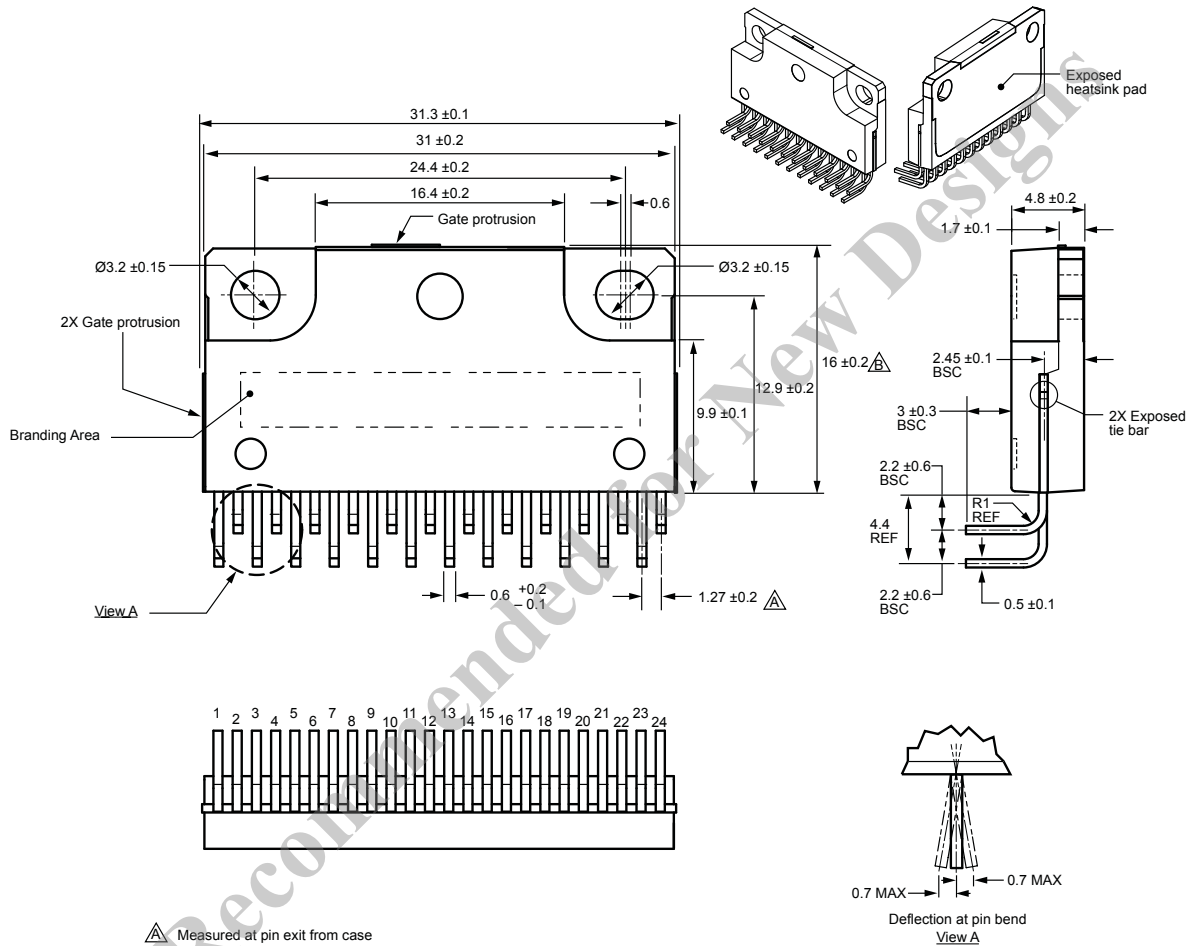

Leadform: 2175

Terminal core material: Cu

Terminal plating: Ni

Recommended attachment: Solder dip (Sn-Ag-Cu)

Dimensions in millimeters

Branding codes (exact appearance at manufacturer discretion):

1st line, type: SLA6868MZ or SLA6870MZ

2nd line, lot: YMDD#

Where: Y is the last digit of the year of manufacture

M is the month (1 to 9, O, N, D)

DD is the date

is the tracking letter



Leadframe plating Pb-free. Device composition complies with the RoHS directive.

SLA6868MZ and SLA6870MZ

High Voltage 3-Phase Motor Drivers

Because reliability can be affected adversely by improper storage environments and handling methods, please observe the following cautions.

Cautions for Storage

- Ensure that storage conditions comply with the standard temperature (5°C to 35°C) and the standard relative humidity (around 40% to 75%); avoid storage locations that experience extreme changes in temperature or humidity.
- Avoid locations where dust or harmful gases are present and avoid direct sunlight.
- Reinspect for rust on leads and solderability of the products that have been stored for a long time.

Cautions for Testing and Handling

When tests are carried out during inspection testing and other standard test periods, protect the products from power surges from the testing device, shorts between the product pins, and wrong connections. Ensure all test parameters are within the ratings specified by Sanken for the products.

Remarks About Using Silicone Grease with a Heatsink

- When silicone grease is used in mounting the products on a heatsink, it shall be applied evenly and thinly. If more silicone grease than required is applied, it may produce excess stress.
- Volatile-type silicone greases may crack after long periods of time, resulting in reduced heat radiation effect. Silicone greases with low consistency (hard grease) may cause cracks in the mold resin when screwing the products to a heatsink.

Our recommended silicone greases for heat radiation purposes, which will not cause any adverse effect on the product life, are indicated below:

Type	Suppliers
G746	Shin-Etsu Chemical Co., Ltd.
YG6260	Momentive Performance Materials Inc.
SC102	Dow Corning Toray Co., Ltd.

Cautions for Mounting to a Heatsink

- When the flatness around the screw hole is insufficient, such as when mounting the products to a heatsink that has an extruded (burred) screw hole, the products can be damaged, even with a lower than recommended screw torque. For mounting the products, the mounting surface flatness should be 0.05 mm or less.

- Please select suitable screws for the product shape. Do not use a flat-head machine screw because of the stress to the products. Self-tapping screws are not recommended. When using self-tapping screws, the screw may enter the hole diagonally, not vertically, depending on the conditions of hole before threading or the work situation. That may stress the products and may cause failures.
- Recommended screw torque: 0.588 to 0.785 N•m (6 to 8 kgf•cm).
- For tightening screws, if a tightening tool (such as a driver) hits the products, the package may crack, and internal stress fractures may occur, which shorten the lifetime of the electrical elements and can cause catastrophic failure. Tightening with an air driver makes a substantial impact. In addition, a screw torque higher than the set torque can be applied and the package may be damaged. Therefore, an electric driver is recommended.
- When the package is tightened at two or more places, first pre-tighten with a lower torque at all places, then tighten with the specified torque. When using a power driver, torque control is mandatory.

Soldering

- When soldering the products, please be sure to minimize the working time, within the following limits:
 - 260±5°C 10±1 s (Flow, 2 times)
 - 380±10°C 5±0.5 s (Soldering iron, 1 time)
- Soldering should be at a distance of at least 1.5 mm from the body of the products.

Electrostatic Discharge

- When handling the products, the operator must be grounded. Grounded wrist straps worn should have at least 1 MΩ of resistance from the operator to ground to prevent shock hazard, and it should be placed near the operator.
- Workbenches where the products are handled should be grounded and be provided with conductive table and floor mats.
- When using measuring equipment such as a curve tracer, the equipment should be grounded.
- When soldering the products, the head of soldering irons or the solder bath must be grounded in order to prevent leak voltages generated by them from being applied to the products.
- The products should always be stored and transported in Sanken shipping containers or conductive containers, or be wrapped in aluminum foil.

-
- The contents in this document are subject to changes, for improvement and other purposes, without notice. Make sure that this is the latest revision of the document before use.
 - Application and operation examples described in this document are quoted for the sole purpose of reference for the use of the products herein and Sanken can assume no responsibility for any infringement of industrial property rights, intellectual property rights or any other rights of Sanken or any third party which may result from its use.
 - Although Sanken undertakes to enhance the quality and reliability of its products, the occurrence of failure and defect of semiconductor products at a certain rate is inevitable. Users of Sanken products are requested to take, at their own risk, preventative measures including safety design of the equipment or systems against any possible injury, death, fires or damages to the society due to device failure or malfunction.
 - Sanken products listed in this document are designed and intended for the use as components in general purpose electronic equipment or apparatus (home appliances, office equipment, telecommunication equipment, measuring equipment, etc.).

When considering the use of Sanken products in the applications where higher reliability is required (transportation equipment and its control systems, traffic signal control systems or equipment, fire/crime alarm systems, various safety devices, etc.), and whenever long life expectancy is required even in general purpose electronic equipment or apparatus, please contact your nearest Sanken sales representative to discuss, prior to the use of the products herein.

The use of Sanken products without the written consent of Sanken in the applications where extremely high reliability is required (aerospace equipment, nuclear power control systems, life support systems, etc.) is strictly prohibited.

- In the case that you use Sanken products or design your products by using Sanken products, the reliability largely depends on the degree of derating to be made to the rated values. Derating may be interpreted as a case that an operation range is set by derating the load from each rated value or surge voltage or noise is considered for derating in order to assure or improve the reliability. In general, derating factors include electric stresses such as electric voltage, electric current, electric power etc., environmental stresses such as ambient temperature, humidity etc. and thermal stress caused due to self-heating of semiconductor products. For these stresses, instantaneous values, maximum values and minimum values must be taken into consideration.

In addition, it should be noted that since power devices or IC's including power devices have large self-heating value, the degree of derating of junction temperature affects the reliability significantly.

- When using the products specified herein by either (i) combining other products or materials therewith or (ii) physically, chemically or otherwise processing or treating the products, please duly consider all possible risks that may result from all such uses in advance and proceed therewith at your own responsibility.
- Anti radioactive ray design is not considered for the products listed herein.
- Sanken assumes no responsibility for any troubles, such as dropping products caused during transportation out of Sanken's distribution network.
- The contents in this document must not be transcribed or copied without Sanken's written consent.

OUR CERTIFICATE

DiGi provide top-quality products and perfect service for customer worldwide through standardization, technological innovation and continuous improvement. DiGi through third-party certification, we stricly control the quality of products and services. Welcome your RFQ to

Email: Info@DiGi-Electronics.com



Tel: +00 852-30501935

RFQ Email: Info@DiGi-Electronics.com

DiGi is a global authorized distributor of electronic components.