

# 74ACT175SJX Datasheet

[www.digi-electronics.com](http://www.digi-electronics.com)

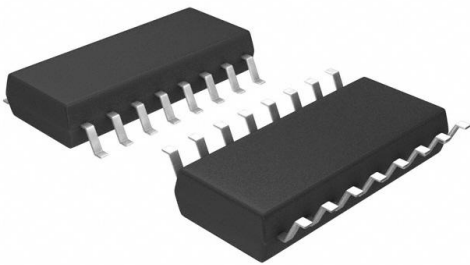

<https://www.DiGi-Electronics.com>

DiGi Electronics Part Number	74ACT175SJX-DG
Manufacturer	<a href="#">onsemi</a>
Manufacturer Product Number	74ACT175SJX
Description	IC FF D-TYPE SNGL 4BIT 16SOP
Detailed Description	Flip Flop 1 Element D-Type 4 Bit Positive Edge 16-S OIC (0.209", 5.30mm Width)



Tel: +00 852-30501935

RFQ Email: [Info@DiGi-Electronics.com](mailto:Info@DiGi-Electronics.com)

DiGi is a global authorized distributor of electronic components.

## Purchase and inquiry

Manufacturer Product Number:

74ACT175SJX

Series:

74ACT

Function:

Master Reset

Output Type:

Complementary

Number of Bits per Element:

4

Max Propagation Delay @ V, Max CL:

11ns @ 5V, 50pF

Current - Output High, Low:

24mA, 24mA

Current - Quiescent (Iq):

40  $\mu$ A

Operating Temperature:

-40°C ~ 85°C (TA)

Supplier Device Package:

16-SOP

Base Product Number:

74ACT175

Manufacturer:

onsemi

Product Status:

Obsolete

Type:

D-Type

Number of Elements:

1

Clock Frequency:

236 MHz

Trigger Type:

Positive Edge

Voltage - Supply:

4.5V ~ 5.5V

Input Capacitance:

4.5 pF

Mounting Type:

Surface Mount

Package / Case:

16-SOIC (0.209", 5.30mm Width)

## Environmental & Export classification

Moisture Sensitivity Level (MSL):

1 (Unlimited)

ECCN:

EAR99

REACH Status:

REACH Unaffected

HTSUS:

8542.39.0001



## 74AC175, 74ACT175 Quad D-Type Flip-Flop

### Features

- $I_{CC}$  reduced by 50%
- Edge-triggered D-type inputs
- Buffered positive edge-triggered clock
- Asynchronous common reset
- True and complement output
- Outputs source/sink 24mA
- ACT175 has TTL-compatible inputs

### General Description

The AC/ACT175 is a high-speed quad D-type flip-flop. The device is useful for general flip-flop requirements where clock and clear inputs are common. The information on the D-type inputs is stored during the LOW-to-HIGH clock transition. Both true and complemented outputs of each flip-flop are provided. A Master Reset input resets all flip-flops, independent of the Clock or D-type inputs, when LOW.

### Ordering Information

Order Number	Package Number	Package Description
74AC175SC	M16A	16-Lead Small Outline Integrated Circuit (SOIC), JEDEC MS-012, 0.150" Narrow Body
74AC175SJ	M16D	16-Lead Small Outline Package (SOP), EIAJ TYPE II, 5.3mm Wide
74AC175MTC	MTC16	16-Lead Thin Shrink Small Outline Package (TSSOP), JEDEC MO-153, 4.4mm Wide
74AC175PC	N16E	16-Lead Plastic Dual-In-Line Package (PDIP), JEDEC MS-001, 0.300" Wide
74ACT175SC	M16A	16-Lead Small Outline Integrated Circuit (SOIC), JEDEC MS-012, 0.150" Narrow Body
74ACT175SJ	M16D	16-Lead Small Outline Package (SOP), EIAJ TYPE II, 5.3mm Wide
74ACT175MTC	MTC16	16-Lead Thin Shrink Small Outline Package (TSSOP), JEDEC MO-153, 4.4mm Wide

Device also available in Tape and Reel. Specify by appending suffix letter "X" to the ordering number.

### Connection Diagram

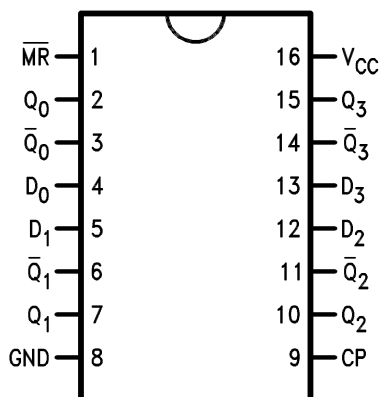

### Pin Descriptions

Pin Names	Description
$D_0$ – $D_3$	Data Inputs
CP	Clock Pulse Input
$\overline{MR}$	Master Reset Input
$Q_0$ – $Q_3$	True Outputs
$\overline{Q_0}$ – $\overline{Q_3}$	Complement Outputs

FACT™ is a trademark of Fairchild Semiconductor Corporation.

### Logic Symbol

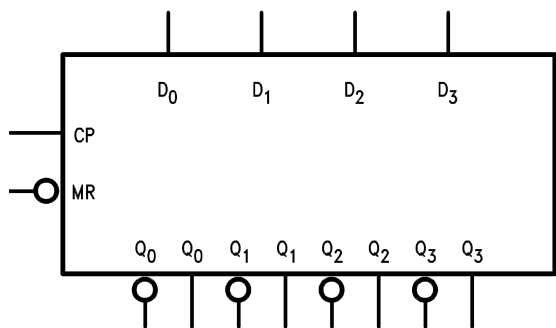

### Functional Description

The AC/ACT175 consists of four edge-triggered D-type flip-flops with individual D inputs and Q and  $\bar{Q}$  outputs. The Clock and Master Reset are common. The four flip-flops will store the state of their individual D inputs on the LOW-to-HIGH clock (CP) transition, causing individual Q and  $\bar{Q}$  outputs to follow. A LOW input on the Master Reset ( $\overline{MR}$ ) will force all Q outputs LOW and  $\bar{Q}$  outputs HIGH independent of Clock or Data inputs. The AC/ACT175 is useful for general logic applications where a common Master Reset and Clock are acceptable.

### Truth Table

Inputs @ $t_n$ , $\overline{MR} = H$	Outputs @ $t_{n+1}$	
$D_n$	$Q_n$	$\bar{Q}_n$
L	L	H
H	H	L

H = HIGH Voltage Level

L = LOW Voltage Level

$t_n$  = Bit Time before Clock Pulse

$t_{n+1}$  = Bit Time after Clock Pulse

### IEEE/IEC

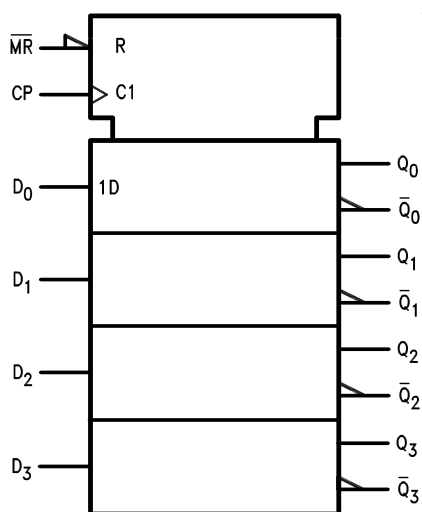

### Logic Diagram

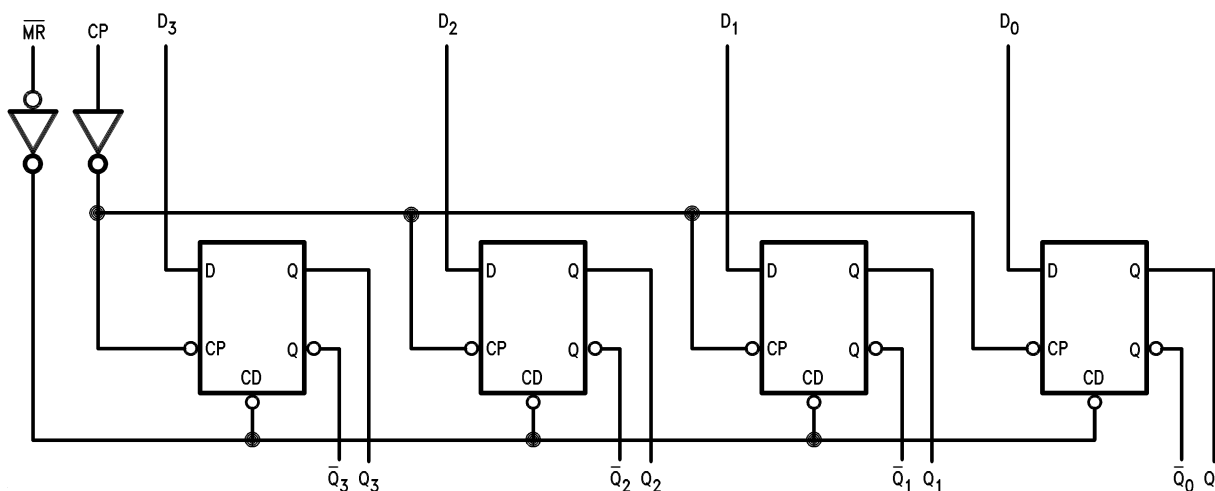

Please note that this diagram is provided only for the understanding of logic operations and should not be used to estimate propagation delays.

Figure 1.

## Absolute Maximum Ratings

Stresses exceeding the absolute maximum ratings may damage the device. The device may not function or be operable above the recommended operating conditions and stressing the parts to these levels is not recommended. In addition, extended exposure to stresses above the recommended operating conditions may affect device reliability. The absolute maximum ratings are stress ratings only.

Symbol	Parameter	Rating
$V_{CC}$	Supply Voltage	-0.5V to +7.0V
$I_{IK}$	DC Input Diode Current $V_I = -0.5V$ $V_I = V_{CC} + 0.5V$	-20mA +20mA
$V_I$	DC Input Voltage	-0.5V to $V_{CC} + 0.5V$
$I_{OK}$	DC Output Diode Current $V_O = -0.5V$ $V_O = V_{CC} + 0.5V$	-20mA +20mA
$V_O$	DC Output Voltage	-0.5V to $V_{CC} + 0.5V$
$I_O$	DC Output Source or Sink Current	$\pm 50mA$
$I_{CC}$ or $I_{GND}$	DC $V_{CC}$ or Ground Current per Output Pin	$\pm 50mA$
$T_{STG}$	Storage Temperature	-65°C to +150°C
$T_J$	Junction Temperature	140°C

## Recommended Operating Conditions

The Recommended Operating Conditions table defines the conditions for actual device operation. Recommended operating conditions are specified to ensure optimal performance to the datasheet specifications. Fairchild does not recommend exceeding them or designing to absolute maximum ratings.

Symbol	Parameter	Rating
$V_{CC}$	Supply Voltage AC ACT	2.0V to 6.0V 4.5V to 5.5V
$V_I$	Input Voltage	0V to $V_{CC}$
$V_O$	Output Voltage	0V to $V_{CC}$
$T_A$	Operating Temperature	-40°C to +85°C
$\Delta V / \Delta t$	Minimum Input Edge Rate, AC Devices: $V_{IN}$ from 30% to 70% of $V_{CC}$ , $V_{CC}$ @ 3.3V, 4.5V, 5.5V	125mV/ns
$\Delta V / \Delta t$	Minimum Input Edge Rate, ACT Devices: $V_{IN}$ from 0.8V to 2.0V, $V_{CC}$ @ 4.5V, 5.5V	125mV/ns

**DC Electrical Characteristics for AC**

Symbol	Parameter	V <sub>CC</sub> (V)	Conditions	T <sub>A</sub> = +25°C		T <sub>A</sub> = -40°C to +85°C		Units		
				Typ.	Guaranteed Limits					
V <sub>IH</sub>	Minimum HIGH Level Input Voltage	3.0	V <sub>OUT</sub> = 0.1V or V <sub>CC</sub> - 0.1V	1.5	2.1	2.1		V		
		4.5		2.25	3.15	3.15				
		5.5		2.75	3.85	3.85				
V <sub>IL</sub>	Maximum LOW Level Input Voltage	3.0	V <sub>OUT</sub> = 0.1V or V <sub>CC</sub> - 0.1V	1.5	0.9	0.9		V		
		4.5		2.25	1.35	1.35				
		5.5		2.75	1.65	1.65				
V <sub>OH</sub>	Minimum HIGH Level Output Voltage	3.0	I <sub>OUT</sub> = -50μA	2.99	2.9	2.9		V		
		4.5		4.49	4.4	4.4				
		5.5		5.49	5.4	5.4				
		3.0	V <sub>IN</sub> = V <sub>IL</sub> or V <sub>IH</sub> : I <sub>OH</sub> = -12mA			2.56	2.46			
		4.5		I <sub>OH</sub> = -24mA			3.86		3.76	
		5.5		I <sub>OH</sub> = -24mA <sup>(1)</sup>			4.86		4.76	
V <sub>OL</sub>	Maximum LOW Level Output Voltage	3.0	I <sub>OUT</sub> = 50μA	0.002	0.1	0.1		V		
		4.5		0.001	0.1	0.1				
		5.5		0.001	0.1	0.1				
		3.0	V <sub>IN</sub> = V <sub>IL</sub> or V <sub>IH</sub> : I <sub>OL</sub> = 12mA			0.36	0.44			
		4.5		I <sub>OL</sub> = 24mA			0.36		0.44	
		5.5		I <sub>OL</sub> = 24mA <sup>(1)</sup>			0.36		0.44	
I <sub>IN</sub> <sup>(3)</sup>	Maximum Input Leakage Current	5.5	V <sub>I</sub> = V <sub>CC</sub> , GND		±0.1	±1.0		μA		
I <sub>OLD</sub>	Minimum Dynamic Output Current <sup>(2)</sup>	5.5	V <sub>OLD</sub> = 1.65V Max.			75		mA		
I <sub>OHD</sub>		5.5	V <sub>OHD</sub> = 3.85V Min.			-75		mA		
I <sub>CC</sub> <sup>(3)</sup>	Maximum Quiescent Supply Current	5.5	V <sub>IN</sub> = V <sub>CC</sub> or GND		4.0	40.0		μA		

**Notes:**

1. All outputs loaded; thresholds on input associated with output under test.
2. Maximum test duration 2.0ms, one output loaded at a time.
3. I<sub>IN</sub> and I<sub>CC</sub> @ 3.0V are guaranteed to be less than or equal to the respective limit @ 5.5V V<sub>CC</sub>.

## DC Electrical Characteristics for ACT

Symbol	Parameter	V <sub>CC</sub> (V)	Conditions	T <sub>A</sub> = +25°C		T <sub>A</sub> = -40°C to +85°C		Units
				Typ.	Guaranteed Limits			
V <sub>IH</sub>	Minimum HIGH Level Input Voltage	4.5	V <sub>OUT</sub> = 0.1V or V <sub>CC</sub> - 0.1V	1.5	2.0	2.0		V
		5.5		1.5	2.0	2.0		
V <sub>IL</sub>	Maximum LOW Level Input Voltage	4.5	V <sub>OUT</sub> = 0.1V or V <sub>CC</sub> - 0.1V	1.5	0.8	0.8		V
		5.5		1.5	0.8	0.8		
V <sub>OH</sub>	Minimum HIGH Level Output Voltage	4.5	I <sub>OUT</sub> = -50μA	4.49	4.4	4.4		V
		5.5		5.49	5.4	5.4		
		4.5	V <sub>IN</sub> = V <sub>IL</sub> or V <sub>IH</sub> : I <sub>OH</sub> = -24mA		3.86	3.76		
		5.5	I <sub>OH</sub> = -24mA <sup>(4)</sup>		4.86	4.76		
V <sub>OL</sub>	Maximum LOW Level Output Voltage	4.5	I <sub>OUT</sub> = 50μA	0.001	0.1	0.1		V
		5.5		0.001	0.1	0.1		
		4.5	V <sub>IN</sub> = V <sub>IL</sub> or V <sub>IH</sub> : I <sub>OL</sub> = 24mA		0.36	0.44		
		5.5	I <sub>OL</sub> = 24mA <sup>(4)</sup>		0.36	0.44		
I <sub>IN</sub>	Maximum Input Leakage Current	5.5	V <sub>I</sub> = V <sub>CC</sub> , GND		±0.1	±1.0		μA
I <sub>CCT</sub>	Maximum I <sub>CC</sub> /Input	5.5	V <sub>I</sub> = V <sub>CC</sub> - 2.1V	0.6		1.5		mA
I <sub>OLD</sub>	Minimum Dynamic Output Current <sup>(5)</sup>	5.5	V <sub>OLD</sub> = 1.65V Max.			75		mA
I <sub>OHD</sub>		5.5	V <sub>OHD</sub> = 3.85V Min.			-75		mA
I <sub>CC</sub>	Maximum Quiescent Supply Current	5.5	V <sub>IN</sub> = V <sub>CC</sub> or GND		4.0	40.0		μA

**Notes:**

- All outputs loaded; thresholds on input associated with output under test.
- Maximum test duration 2.0ms, one output loaded at a time.

## AC Electrical Characteristics for AC

Symbol	Parameter	$V_{CC}$ (V) <sup>(6)</sup>	$T_A = +25^\circ\text{C}$ , $C_L = 50\text{pF}$			$T_A = -40^\circ\text{C to } +85^\circ\text{C}$ , $C_L = 50\text{pF}$		Units
			Min.	Typ.	Max.	Min.	Max.	
$f_{\text{MAX}}$	Maximum Clock Frequency	3.3	149	214		139		MHz
		5.0	187	244		187		
$t_{\text{PLH}}$	Propagation Delay, CP to $Q_n$ or $\overline{Q}_n$	3.3	2.0	9.5	12.0	2.0	13.5	ns
		5.0	1.5	7.0	9.0	1.0	9.5	
$t_{\text{PHL}}$	Propagation Delay, CP to $Q_n$ or $\overline{Q}_n$	3.3	2.5	8.5	13.0	2.0	14.5	ns
		5.0	1.5	6.0	9.5	1.5	10.5	
$t_{\text{PLH}}$	Propagation Delay, $\overline{\text{MR}}$ to $Q_n$	3.3	3.0	7.5	12.5	2.5	13.5	ns
		5.0	2.0	5.5	9.0	1.5	10.0	
$t_{\text{PHL}}$	Propagation Delay, $\overline{\text{MR}}$ to $Q_n$	3.3	3.0	8.5	11.0	2.5	12.5	ns
		5.0	2.0	6.0	8.5	1.5	9.0	

## Note:

6. Voltage range 3.3 is  $3.3\text{V} \pm 0.3\text{V}$ . Voltage range 5.0 is  $5.0\text{V} \pm 0.5\text{V}$ .

## AC Operating Requirements for AC

Symbol	Parameter	$V_{CC}$ (V) <sup>(7)</sup>	$T_A = +25^\circ\text{C}$ , $C_L = 50\text{pF}$		$T_A = -40^\circ\text{C to } +85^\circ\text{C}$ , $C_L = 50\text{pF}$		Units
			Typ.	Guaranteed Minimum			
$t_S$	Setup Time, HIGH or LOW, $D_n$ to CP	3.3	2.0	4.5	4.5		ns
		5.0	1.0	3.0	3.0		
$t_H$	Hold Time, HIGH or LOW, $D_n$ to CP	3.3	1.0	1.0	1.0		ns
		5.0	1.0	1.0	1.0		
$t_W$	CP Pulse Width, HIGH or LOW	3.3	2.5	4.5	4.5		ns
		5.0	2.0	3.5	3.5		
$t_W$	$\overline{\text{MR}}$ Pulse Width, LOW	3.3	2.5	4.5	5.0		ns
		5.0	2.0	3.5	3.5		
$t_{\text{REC}}$	Recovery Time, $\overline{\text{MR}}$ to CP	3.3	-2.0	0	0		ns
		5.0	-1.0	0	0		

## Note:

7. Voltage range 3.3 is  $3.3\text{V} \pm 0.3\text{V}$ . Voltage range 5.0 is  $5.0\text{V} \pm 0.5\text{V}$ .



**AC Electrical Characteristics for ACT**

Symbol	Parameter	V <sub>CC</sub> (V) <sup>(8)</sup>	T <sub>A</sub> = +25°C, C <sub>L</sub> = 50pF			T <sub>A</sub> = -40°C to +85°C, C <sub>L</sub> = 50pF		Units
			Min.	Typ.	Max.	Min.	Max.	
f <sub>MAX</sub>	Maximum Clock Frequency	5.0	175	236		145		MHz
t <sub>PLH</sub>	Propagation Delay, CP to Q <sub>n</sub> or $\overline{Q}_n$	5.0	2.0	6.0	10.0	1.5	11.0	ns
t <sub>PHL</sub>	Propagation Delay, CP to Q <sub>n</sub> or $\overline{Q}_n$	5.0	2.0	7.0	11.0	1.5	12.0	ns
t <sub>PLH</sub>	Propagation Delay, $\overline{MR}$ to $\overline{Q}_n$	5.0	2.0	6.0	9.5	1.5	10.5	ns
t <sub>PHL</sub>	Propagation Delay, $\overline{MR}$ to Q <sub>n</sub>	5.0	2.0	5.5	9.5	1.5	10.5	ns

**Note:**

8. Voltage Range 5.0 is 5.0V ± 0.5V.

**AC Operating Requirements for ACT**

Symbol	Parameter	V <sub>CC</sub> (V) <sup>(9)</sup>	T <sub>A</sub> = +25°C, C <sub>L</sub> = 50pF		T <sub>A</sub> = -40°C to +85°C, C <sub>L</sub> = 50pF		Units
			Typ.	Guaranteed Minimum			
t <sub>S</sub> (H)	Setup Time, D <sub>n</sub> to CP	5.0	3.0	2.0	2.0		ns
t <sub>S</sub> (L)			3.0	2.5	2.5		
t <sub>H</sub>	Hold Time, HIGH or LOW, D <sub>n</sub> to CP	5.0	0	1.0	1.0		ns
t <sub>W</sub>	CP Pulse Width, HIGH or LOW	5.0	4.0	3.0	3.5		ns
t <sub>W</sub>	$\overline{MR}$ Pulse Width, LOW	5.0	4.0	3.0	4.0		ns
t <sub>rec</sub>	Recovery Time, $\overline{MR}$ to CP	5.0	0	0	0		ns

**Note:**

9. Voltage Range 5.0 is 5.0V ± 0.5V.

**Capacitance**

Symbol	Parameter	Conditions	Typ.	Units
C <sub>IN</sub>	Input Capacitance	V <sub>CC</sub> = OPEN	4.5	pF
C <sub>PD</sub>	Power Dissipation Capacitance	V <sub>CC</sub> = 5.0V	45.0	pF



**Physical Dimensions** (Continued)

Dimensions are in millimeters unless otherwise noted.

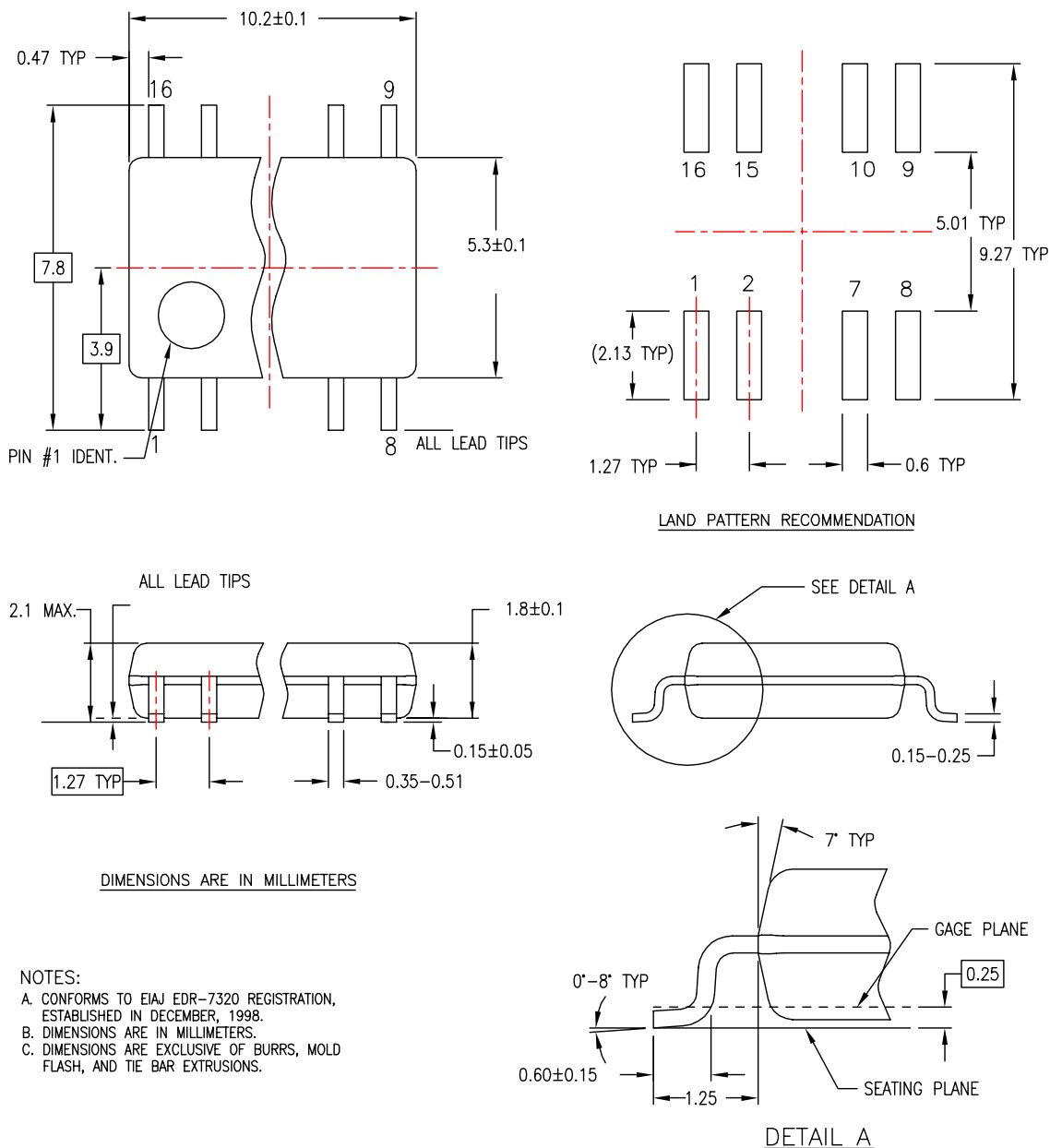

M16DREVC

**Figure 3. 16-Lead Small Outline Package (SOP), EIAJ TYPE II, 5.3mm Wide Package Number M16D**

**Physical Dimensions** (Continued)

Dimensions are in millimeters unless otherwise noted.

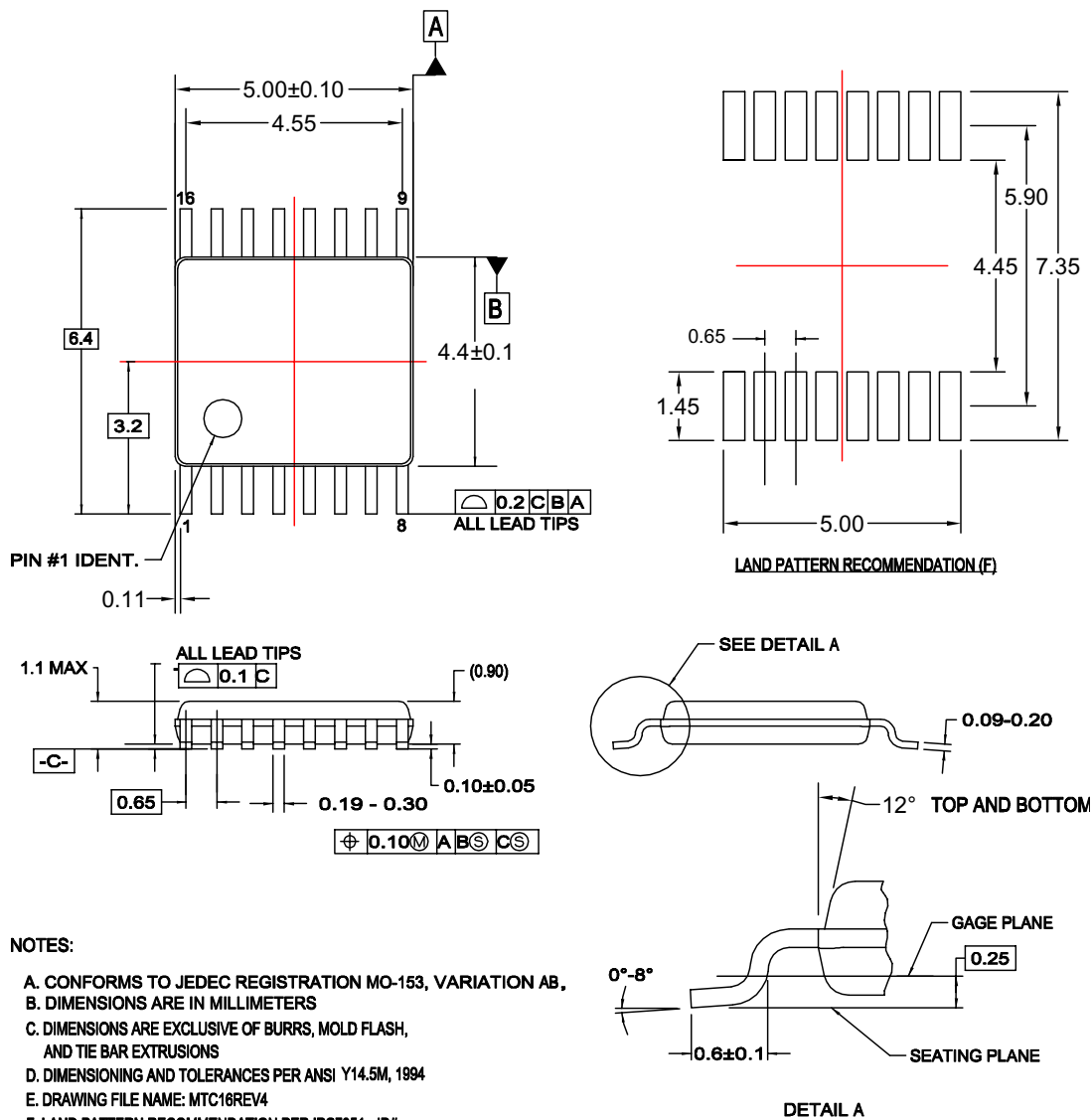

**NOTES:**

- A. CONFORMS TO JEDEC REGISTRATION MO-153, VARIATION AB,
- B. DIMENSIONS ARE IN MILLIMETERS
- C. DIMENSIONS ARE EXCLUSIVE OF BURRS, MOLD FLASH, AND TIE BAR EXTRUSIONS
- D. DIMENSIONING AND TOLERANCES PER ANSI Y14.5M, 1994
- E. DRAWING FILE NAME: MTC16REV4
- F. LAND PATTERN RECOMMENDATION PER IPC7351 - ID# TSOP65P640X110-16N

MTC16rev4

**Figure 4. 16-Lead Thin Shrink Small Outline Package (TSSOP), JEDEC MO-153, 4.4mm Wide Package Number MTC16**

**Physical Dimensions** (Continued)

Dimensions are in inches (millimeters) unless otherwise noted.

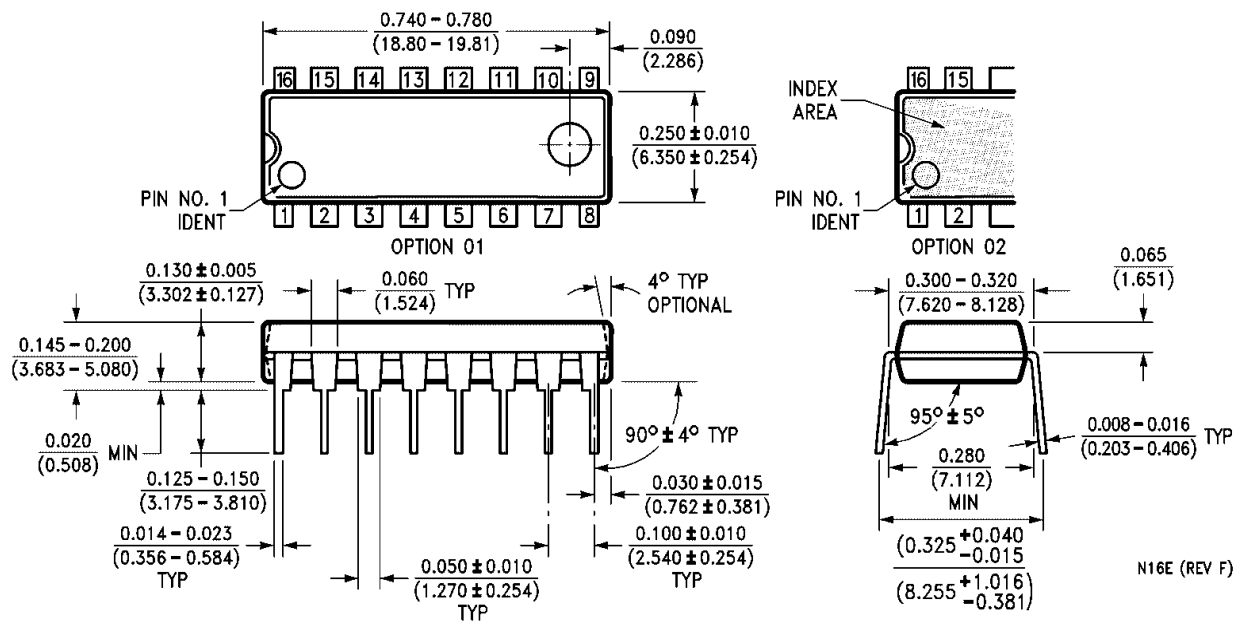



Figure 5. 16-Lead Plastic Dual-In-Line Package (PDIP), JEDEC MS-001, 0.300" Wide Package Number N16E

N16E (REV F)



## TRADEMARKS

The following are registered and unregistered trademarks Fairchild Semiconductor owns or is authorized to use and is not intended to be an exhaustive list of all such trademarks.

ACEx <sup>®</sup>	HiSeC <sup>™</sup>	Programmable Active Droop <sup>™</sup>	TinyLogic <sup>®</sup>
Across the board. Around the world. <sup>™</sup>	<i>i-Lo</i> <sup>™</sup>	QFET <sup>®</sup>	TINYOPTO <sup>™</sup>
ActiveArray <sup>™</sup>	ImpliedDisconnect <sup>™</sup>	QS <sup>™</sup>	TinyPower <sup>™</sup>
Bottomless <sup>™</sup>	IntelliMAX <sup>™</sup>	QT Optoelectronics <sup>™</sup>	TinyWire <sup>™</sup>
Build it Now <sup>™</sup>	ISOPLANAR <sup>™</sup>	Quiet Series <sup>™</sup>	TruTranslation <sup>™</sup>
CoolFET <sup>™</sup>	MICROCOUPLER <sup>™</sup>	RapidConfigure <sup>™</sup>	μSerDes <sup>™</sup>
CROSSVOLT <sup>™</sup>	MicroPak <sup>™</sup>	RapidConnect <sup>™</sup>	UHC <sup>®</sup>
CTL <sup>™</sup>	MICROWIRE <sup>™</sup>	ScalarPump <sup>™</sup>	UniFET <sup>™</sup>
Current Transfer Logic <sup>™</sup>	MSX <sup>™</sup>	SMART START <sup>™</sup>	VCX <sup>™</sup>
DOME <sup>™</sup>	MSXPro <sup>™</sup>	SPM <sup>®</sup>	Wire <sup>™</sup>
E <sup>2</sup> CMOS <sup>™</sup>	OCX <sup>™</sup>	STEALTH <sup>™</sup>	
EcoSPARK <sup>®</sup>	OCXPro <sup>™</sup>	SuperFET <sup>™</sup>	
EnSigna <sup>™</sup>	OPTOLOGIC <sup>®</sup>	SuperSOT <sup>™</sup> -3	
FACT Quiet Series <sup>™</sup>	OPTOPLANAR <sup>®</sup>	SuperSOT <sup>™</sup> -6	
FACT <sup>®</sup>	PACMAN <sup>™</sup>	SuperSOT <sup>™</sup> -8	
FAST <sup>®</sup>	POP <sup>™</sup>	SyncFET <sup>™</sup>	
FASTr <sup>™</sup>	Power220 <sup>®</sup>	TCM <sup>™</sup>	
FPS <sup>™</sup>	Power247 <sup>®</sup>	The Power Franchise <sup>®</sup>	
FRFET <sup>®</sup>	PowerEdge <sup>™</sup>	 ™	
GlobalOptoisolator <sup>™</sup>	PowerSaver <sup>™</sup>	TinyBoost <sup>™</sup>	
GTO <sup>™</sup>	PowerTrench <sup>®</sup>	TinyBuck <sup>™</sup>	

## DISCLAIMER

FAIRCHILD SEMICONDUCTOR RESERVES THE RIGHT TO MAKE CHANGES WITHOUT FURTHER NOTICE TO ANY PRODUCTS HEREIN TO IMPROVE RELIABILITY, FUNCTION OR DESIGN. FAIRCHILD DOES NOT ASSUME ANY LIABILITY ARISING OUT OF THE APPLICATION OR USE OF ANY PRODUCT OR CIRCUIT DESCRIBED HEREIN; NEITHER DOES IT CONVEY ANY LICENSE UNDER ITS PATENT RIGHTS, NOR THE RIGHTS OF OTHERS. THESE SPECIFICATIONS DO NOT EXPAND THE TERMS OF FAIRCHILD'S WORLDWIDE TERMS AND CONDITIONS, SPECIFICALLY THE WARRANTY THEREIN, WHICH COVERS THESE PRODUCTS.

## LIFE SUPPORT POLICY

FAIRCHILD'S PRODUCTS ARE NOT AUTHORIZED FOR USE AS CRITICAL COMPONENTS IN LIFE SUPPORT DEVICES OR SYSTEMS WITHOUT THE EXPRESS WRITTEN APPROVAL OF FAIRCHILD SEMICONDUCTOR CORPORATION.

As used herein:

1. Life support devices or systems are devices or systems which, (a) are intended for surgical implant into the body or (b) support or sustain life, and (c) whose failure to perform when properly used in accordance with instructions for use provided in the labeling, can be reasonably expected to result in a significant injury of the user.
2. A critical component in any component of a life support, device, or system whose failure to perform can be reasonably expected to cause the failure of the life support device or system, or to affect its safety or effectiveness.

## PRODUCT STATUS DEFINITIONS

### Definition of Terms

Datasheet Identification	Product Status	Definition
Advance Information	Formative or In Design	This datasheet contains the design specifications for product development. Specifications may change in any manner without notice.
Preliminary	First Production	This datasheet contains preliminary data; supplementary data will be published at a later date. Fairchild Semiconductor reserves the right to make changes at any time without notice to improve design.
No Identification Needed	Full Production	This datasheet contains final specifications. Fairchild Semiconductor reserves the right to make changes at any time without notice to improve design.
Obsolete	Not In Production	This datasheet contains specifications on a product that has been discontinued by Fairchild Semiconductor. The datasheet is printed for reference information only.

Rev. I24

## OUR CERTIFICATE

DiGi provide top-quality products and perfect service for customer worldwide through standardization, technological innovation and continuous improvement. DiGi through third-party certification, we stricly control the quality of products and services. Welcome your RFQ to

Email: [Info@DiGi-Electronics.com](mailto:Info@DiGi-Electronics.com)



Tel: +00 852-30501935

RFQ Email: [Info@DiGi-Electronics.com](mailto:Info@DiGi-Electronics.com)

DiGi is a global authorized distributor of electronic components.