

# CAT5114VI-50-GT3 Datasheet

[www.digi-electronics.com](http://www.digi-electronics.com)

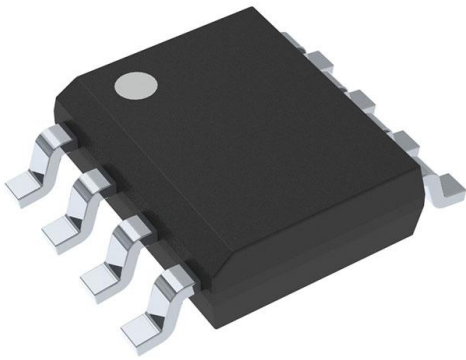

<https://www.DiGi-Electronics.com>

DiGi Electronics Part Number	CAT5114VI-50-GT3-DG
Manufacturer	<a href="#">onsemi</a>
Manufacturer Product Number	CAT5114VI-50-GT3
Description	IC DGTL POT 50KOHM 32TAP 8SOIC
Detailed Description	Digital Potentiometer 50k Ohm 1 Circuit 32 Taps Up /Down (U/D, INC, CS) Interface 8-SOIC

This model CAT5114VI-50-GT3 is available at DiGi Electronics.

DiGi Electronics offers a global database of semiconductor and electronic component datasheets.

We welcome your inquiries regarding pricing, lead time, or other product-related questions.

 [Request a Quote](#)

 [Datasheet Search](#)



Tel: +00 852-30501935

RFQ Email: [Info@DiGi-Electronics.com](mailto:Info@DiGi-Electronics.com)

DiGi is a global authorized distributor of electronic components.

## Purchase and inquiry

Manufacturer Product Number:

CAT5114VI-50-GT3

Series:

-

DiGi-Electronics Programmable:

Not Verified

Configuration:

Potentiometer

Number of Taps:

32

Interface:

Up/Down (U/D, INC, CS)

Voltage - Supply:

2.5V ~ 6V

Tolerance:

±20%

Mounting Type:

Surface Mount

Package / Case:

8-SOIC (0.154", 3.90mm Width)

Resistance - Wiper (Ohms) (Typ):

150

Manufacturer:

onsemi

Product Status:

Obsolete

Taper:

Linear

Number of Circuits:

1

Resistance (Ohms):

50k

Memory Type:

Non-Volatile

Features:

-

Temperature Coefficient (Typ):

300ppm/°C

Supplier Device Package:

8-SOIC

Operating Temperature:

-40°C ~ 85°C

Base Product Number:

CAT5114

## Environmental & Export classification

Moisture Sensitivity Level (MSL):

1 (Unlimited)

ECCN:

EAR99

REACH Status:

REACH Unaffected

HTSUS:

8542.39.0001

# 32-tap Digital Potentiometer (POT)

## CAT5114

### Description

The CAT5114 is a single digital POT designed as an electronic replacement for mechanical potentiometers and trim pots. Ideal for automated adjustments on high volume production lines, they are also well suited for applications where equipment requiring periodic adjustment is either difficult to access or located in a hazardous or remote environment.

The CAT5114 contains a 32-tap series resistor array connected between two terminals  $R_H$  and  $R_L$ . An up/down counter and decoder that are controlled by three input pins, determines which tap is connected to the wiper,  $R_W$ . The wiper setting, stored in nonvolatile memory, is not lost when the device is powered down and is automatically reinstated when power is returned. The wiper can be adjusted to test new system values without affecting the stored setting. Wiper-control of the CAT5114 is accomplished with three input control pins,  $\overline{CS}$ ,  $U/\overline{D}$ , and  $\overline{INC}$ . The  $\overline{INC}$  input increments the wiper in the direction which is determined by the logic state of the  $U/\overline{D}$  input. The  $\overline{CS}$  input is used to select the device and also store the wiper position prior to power down.

The digital POT can be used as a three-terminal resistive divider or as a two-terminal variable resistor. Digital POTs bring variability and programmability to a wide variety of applications including control, parameter adjustments, and signal processing.

### Features

- 32-position Linear Taper Potentiometer
- Non-volatile EEPROM Wiper Storage
- Low Standby Current
- Single Supply Operation: 2.5 V – 6.0 V
- Increment Up/Down Serial Interface
- Resistance Values: 10 k $\Omega$ , 50 k $\Omega$  and 100 k $\Omega$
- Available in PDIP, SOIC, TSSOP, MSOP and Space Saving 2 × 3 mm TDFN Packages
- These Devices are Pb-Free, Halogen Free/BFR Free and are RoHS Compliant

### Applications

- Automated Product Calibration
- Remote Control Adjustments
- Offset, Gain and Zero Control
- Tamper-proof Calibrations
- Contrast, Brightness and Volume Controls
- Motor Controls and Feedback Systems
- Programmable Analog Functions



SOIC-8  
V SUFFIX  
CASE 751BD

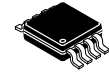

MSOP-8  
Z SUFFIX  
CASE 846AD

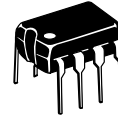

PDIP-8  
L SUFFIX  
CASE 646AA

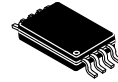

TSSOP-8  
Y SUFFIX  
CASE 948AL



TDFN-8  
VP2 SUFFIX  
CASE 511AK

### PIN CONFIGURATIONS

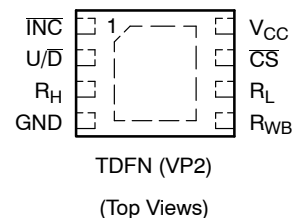
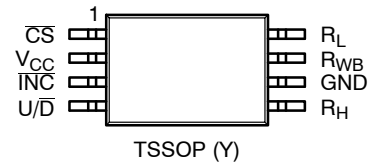
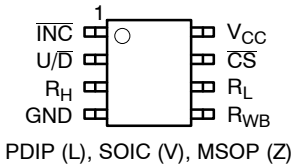

### ORDERING INFORMATION

See detailed ordering and shipping information in the package dimensions section on page 9 of this data sheet.

# CAT5114

## DEVICE MARKING INFORMATION

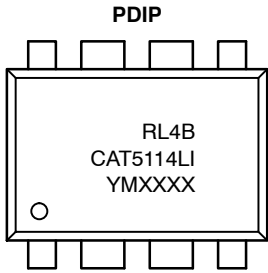

R = Resistance:  
 2 = 10 kΩ  
 4 = 50 kΩ  
 5 = 100 kΩ

L = Assembly Location  
 4 = Lead Finish - NiPdAu  
 B = Product Revision (Fixed as "B")  
 CAT5114L = Device Code (PDIP)  
 CAT5114V = Device Code (SOIC)  
 I = Temperature Range (Industrial)  
 Y = Production Year (Last Digit)  
 M = Production Month (1-9, O, N, D)  
 XXXX = Last Four Digits of Assembly Lot Number

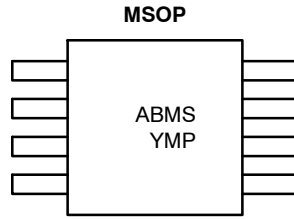
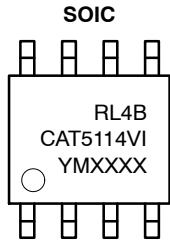

ABMS = CAT5114ZI-10-GT3  
 ABMT = CAT5114ZI-50-GT3  
 ABTH = CAT5114ZI-00-GT3  
 Y = Production Year (Last Digit)  
 M = Production Month (1-9, O, N, D)  
 P = Product Revision

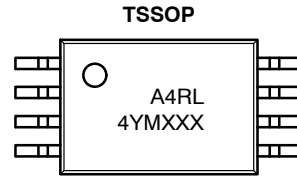

A4 = Device Code  
 R = Resistance:  
 2 = 10 kΩ  
 4 = 50 kΩ  
 5 = 100 kΩ

L = Assembly Location  
 4 = Lead Finish - NiPdAu  
 Y = Production Year (last digit)  
 M = Production Month (1-9, O, N, D)  
 XXX = Last Three Digits of Assembly Lot Number

### TDFN



EF = CAT5114VP2I10GT3  
 HF = CAT5114VP2I50GT3  
 GW = CAT5114VP2I00GT3  
 L = Assembly Location  
 XXX = Last Three Digits of Assembly Lot Number  
 Y = Production Year (Last Digit)  
 M = Production Month (1-9, O, N, D)

## Functional Diagram

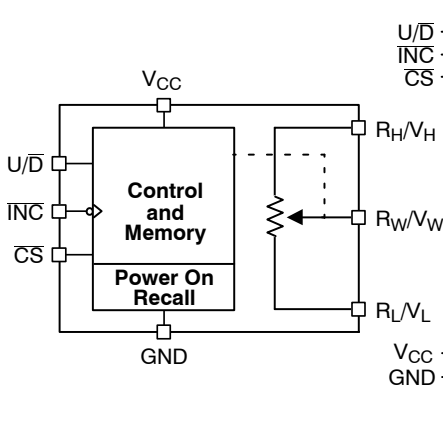

Figure 1. General

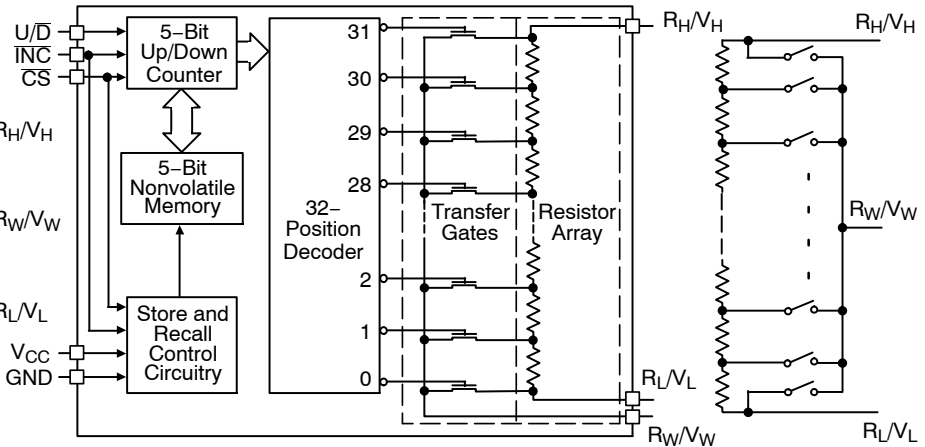

Figure 2. Detailed

Figure 3. Electronic Potentiometer Implementation

**CAT5114****Table 1. PIN DESCRIPTIONS**

Name	Function
$\overline{\text{INC}}$	Increment Control
$\text{U}/\overline{\text{D}}$	Up/Down Control
$\text{R}_\text{H}$	Potentiometer High Terminal
GND	Ground
$\text{R}_\text{W}$	Wiper Terminal
$\text{R}_\text{L}$	Potentiometer Low Terminal
$\overline{\text{CS}}$	Chip Select
$\text{V}_\text{CC}$	Supply Voltage

**Pin Function** **$\overline{\text{INC}}$ : Increment Control Input**

The  $\overline{\text{INC}}$  input moves the wiper in the up or down direction determined by the condition of the  $\text{U}/\overline{\text{D}}$  input.

 **$\text{U}/\overline{\text{D}}$ : Up/Down Control Input**

The  $\text{U}/\overline{\text{D}}$  input controls the direction of the wiper movement. When in a high state and  $\overline{\text{CS}}$  is low, any high-to-low transition on  $\overline{\text{INC}}$  will cause the wiper to move one increment toward the  $\text{R}_\text{H}$  terminal. When in a low state and  $\overline{\text{CS}}$  is low, any high-to-low transition on  $\overline{\text{INC}}$  will cause the wiper to move one increment towards the  $\text{R}_\text{L}$  terminal.

 **$\text{R}_\text{H}$ : High End Potentiometer Terminal**

$\text{R}_\text{H}$  is the high end terminal of the potentiometer. It is not required that this terminal be connected to a potential greater than the  $\text{R}_\text{L}$  terminal. Voltage applied to the  $\text{R}_\text{H}$  terminal cannot exceed the supply voltage,  $\text{V}_\text{CC}$  or go below ground, GND.

 **$\text{R}_\text{W}$ : Wiper Potentiometer Terminal**

$\text{R}_\text{W}$  is the wiper terminal of the potentiometer. Its position on the resistor array is controlled by the control inputs,  $\overline{\text{INC}}$ ,  $\text{U}/\overline{\text{D}}$  and  $\overline{\text{CS}}$ . Voltage applied to the  $\text{R}_\text{W}$  terminal cannot exceed the supply voltage,  $\text{V}_\text{CC}$  or go below ground, GND.

 **$\text{R}_\text{L}$ : Low End Potentiometer Terminal**

$\text{R}_\text{L}$  is the low end terminal of the potentiometer. It is not required that this terminal be connected to a potential less

than the  $\text{R}_\text{H}$  terminal. Voltage applied to the  $\text{R}_\text{L}$  terminal cannot exceed the supply voltage,  $\text{V}_\text{CC}$  or go below ground, GND.  $\text{R}_\text{L}$  and  $\text{R}_\text{H}$  are electrically interchangeable.

 **$\overline{\text{CS}}$ : Chip Select**

The chip select input is used to activate the control input of the CAT5114 and is active low. When in a high state, activity on the  $\overline{\text{INC}}$  and  $\text{U}/\overline{\text{D}}$  inputs will not affect or change the position of the wiper.

**Device Operation**

The CAT5114 operates like a digitally controlled potentiometer with  $\text{R}_\text{H}$  and  $\text{R}_\text{L}$  equivalent to the high and low terminals and  $\text{R}_\text{W}$  equivalent to the mechanical potentiometer's wiper. There are 32 available tap positions including the resistor end points,  $\text{R}_\text{H}$  and  $\text{R}_\text{L}$ . There are 31 resistor elements connected in series between the  $\text{R}_\text{H}$  and  $\text{R}_\text{L}$  terminals. The wiper terminal is connected to one of the 32 taps and controlled by three inputs,  $\overline{\text{INC}}$ ,  $\text{U}/\overline{\text{D}}$  and  $\overline{\text{CS}}$ . These inputs control a five-bit up/down counter whose output is decoded to select the wiper position. The selected wiper position can be stored in nonvolatile memory using the  $\overline{\text{INC}}$  and  $\overline{\text{CS}}$  inputs.

With  $\overline{\text{CS}}$  set LOW the CAT5114 is selected and will respond to the  $\text{U}/\overline{\text{D}}$  and  $\overline{\text{INC}}$  inputs. HIGH to LOW transitions on  $\overline{\text{INC}}$  will increment or decrement the wiper (depending on the state of the  $\text{U}/\overline{\text{D}}$  input and five-bit counter). The wiper, when at either fixed terminal, acts like its mechanical equivalent and does not move beyond the last position. The value of the counter is stored in nonvolatile memory whenever  $\overline{\text{CS}}$  transitions HIGH while the  $\overline{\text{INC}}$  input is also HIGH. When the CAT5114 is powered-down, the last stored wiper counter position is maintained in the nonvolatile memory. When power is restored, the contents of the memory are recalled and the counter is set to the value stored.

With  $\overline{\text{INC}}$  set low, the CAT5114 may be de-selected and powered down without storing the current wiper position in nonvolatile memory. This allows the system to always power up to a preset value stored in nonvolatile memory.

**CAT5114****Table 2. OPERATION MODES**

INC	CS	U/D	Operation
High to Low	Low	High	Wiper toward H
High to Low	Low	Low	Wiper toward L
High	Low to High	X	Store Wiper Position
Low	Low to High	X	No Store, Return to Standby
X	High	X	Standby

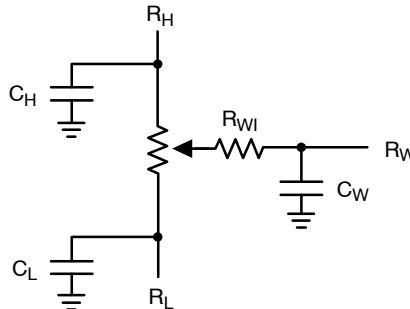
**Figure 4. Potentiometer Equivalent Circuit****Table 3. ABSOLUTE MAXIMUM RATINGS**

Parameters	Ratings	Units
Supply Voltage $V_{CC}$ to GND	-0.5 to +7	V
Inputs CS to GND	-0.5 to $V_{CC} + 0.5$	V
INC to GND	-0.5 to $V_{CC} + 0.5$	V
U/D to GND	-0.5 to $V_{CC} + 0.5$	V
H to GND	-0.5 to $V_{CC} + 0.5$	V
L to GND	-0.5 to $V_{CC} + 0.5$	V
W to GND	-0.5 to $V_{CC} + 0.5$	V
Operating Ambient Temperature Industrial ('I' suffix)	-40 to +85	°C
Junction Temperature	+150	°C
Storage Temperature	-65 to 150	°C
Lead Soldering (10 s max)	+300	°C

Stresses exceeding those listed in the Maximum Ratings table may damage the device. If any of these limits are exceeded, device functionality should not be assumed, damage may occur and reliability may be affected.

**Table 4. RELIABILITY CHARACTERISTICS**

Symbol	Parameter	Test Method	Min	Typ	Max	Units
$V_{ZAP}$ (Note 1)	ESD Susceptibility	MIL-STD-883, Test Method 3015	2000			V
$I_{LTH}$ (Notes 1, 2)	Latch-up	JEDEC Standard 17	100			mA
$T_{DR}$	Data Retention	MIL-STD-883, Test Method 1008	100			Years
$N_{END}$	Endurance	MIL-STD-883, Test Method 1003	1,000,000			Stores

1. This parameter is tested initially and after a design or process change that affects the parameter.
2. Latch-up protection is provided for stresses up to 100 mA on address and data pins from -1 V to  $V_{CC} + 1$  V.

## CAT5114

Table 5. DC ELECTRICAL CHARACTERISTICS ( $V_{CC} = +2.5\text{ V}$  to  $+6\text{ V}$  unless otherwise specified)

Symbol	Parameter	Conditions	Min	Typ	Max	Units
<b>POWER SUPPLY</b>						
$V_{CC}$	Operating Voltage Range		2.5	–	6.0	V
$I_{CC1}$	Supply Current (Increment)	$V_{CC} = 6\text{ V}$ , $f = 1\text{ MHz}$ , $I_W = 0$	–	–	100	$\mu\text{A}$
		$V_{CC} = 6\text{ V}$ , $f = 250\text{ kHz}$ , $I_W = 0$	–	–	50	$\mu\text{A}$
$I_{CC2}$	Supply Current (Write)	Programming, $V_{CC} = 6\text{ V}$	–	–	1000	$\mu\text{A}$
		$V_{CC} = 3\text{ V}$	–	–	500	$\mu\text{A}$
$I_{SB1}$ (Note 4)	Supply Current (Standby)	$\overline{CS} = V_{CC} - 0.3\text{ V}$ $U/\overline{D}$ , $\overline{INC} = V_{CC} - 0.3\text{ V}$ or GND	–	–	1	$\mu\text{A}$
<b>LOGIC INPUTS</b>						
$I_{IH}$	Input Leakage Current	$V_{IN} = V_{CC}$	–	–	10	$\mu\text{A}$
$I_{IL}$	Input Leakage Current	$V_{IN} = 0\text{ V}$	–	–	–10	$\mu\text{A}$
$V_{IH2}$	CMOS High Level Input Voltage	$2.5\text{ V} \leq V_{CC} \leq 6\text{ V}$	$V_{CC} \times 0.7$	–	$V_{CC} + 0.3$	V
$V_{IL2}$	CMOS Low Level Input Voltage		–0.3	–	$V_{CC} \times 0.2$	V
<b>POTENTIOMETER CHARACTERISTICS</b>						
$R_{POT}$	Potentiometer Resistance	–10 Device		10		k $\Omega$
		–50 Device		50		
		–00 Device		100		
	Pot. Resistance Tolerance				$\pm 20$	%
$V_{RH}$	Voltage on $R_H$ pin		0		$V_{CC}$	V
$V_{RL}$	Voltage on $R_L$ pin		0		$V_{CC}$	V
	Resolution			3.2		%
INL	Integral Linearity Error	$I_W \leq 2\ \mu\text{A}$		0.5	1	LSB
DNL	Differential Linearity Error	$I_W \leq 2\ \mu\text{A}$		0.25	0.5	LSB
$R_{WI}$	Wiper Resistance	$V_{CC} = 5\text{ V}$ , $I_W = 1\text{ mA}$		70	200	$\Omega$
		$V_{CC} = 2.5\text{ V}$ , $I_W = 1\text{ mA}$		150	400	$\Omega$
$I_W$	Wiper Current		–4.4		4.4	mA
$TC_{RPOT}$	TC of Pot Resistance			300		ppm/ $^{\circ}\text{C}$
$TC_{RATIO}$	Ratiometric TC				20	ppm/ $^{\circ}\text{C}$
$V_N$	Noise	100 kHz / 1 kHz		8/24		nV/ $\sqrt{\text{Hz}}$
$C_H/C_L/C_W$	Potentiometer Capacitances			8/8/25		pF
fc	Frequency Response	Passive Attenuator, 10 k $\Omega$		1.7		MHz

3. This parameter is tested initially and after a design or process change that affects the parameter.

4. Latch-up protection is provided for stresses up to 100 mA on address and data pins from  $-1\text{ V}$  to  $V_{CC} + 1\text{ V}$ .

5.  $I_W$  = source or sink.

6. These parameters are periodically sampled and are not 100% tested.

**CAT5114****Table 6. AC TEST CONDITIONS**

V <sub>CC</sub> Range	2.5 V ≤ V <sub>CC</sub> ≤ 6 V
Input Pulse Levels	0.2 × V <sub>CC</sub> to 0.7 × V <sub>CC</sub>
Input Rise and Fall Times	10 ns
Input Reference Levels	0.5 × V <sub>CC</sub>

**Table 7. AC OPERATING CHARACTERISTICS** (V<sub>CC</sub> = +2.5 V to +6.0 V, V<sub>H</sub> = V<sub>CC</sub>, V<sub>L</sub> = 0 V, unless otherwise specified)

Symbol	Parameter	Min	Typ (Note 7)	Max	Units
t <sub>CI</sub>	$\overline{CS}$ to $\overline{INC}$ Setup	100	–	–	ns
t <sub>DI</sub>	U/D to $\overline{INC}$ Setup	50	–	–	ns
t <sub>ID</sub>	U/D to $\overline{INC}$ Hold	100	–	–	ns
t <sub>IL</sub>	$\overline{INC}$ LOW Period	250	–	–	ns
t <sub>IH</sub>	$\overline{INC}$ HIGH Period	250	–	–	ns
t <sub>IC</sub>	$\overline{INC}$ Inactive to $\overline{CS}$ Inactive	1	–	–	μs
t <sub>CPH</sub>	$\overline{CS}$ Deselect Time (NO STORE)	100	–	–	ns
t <sub>CPH</sub>	$\overline{CS}$ Deselect Time (STORE)	10	–	–	ms
t <sub>IW</sub>	$\overline{INC}$ to V <sub>OUT</sub> Change	–	1	5	μs
t <sub>CYC</sub>	$\overline{INC}$ Cycle Time	1	–	–	μs
t <sub>R</sub> , t <sub>F</sub> (Note 8)	$\overline{INC}$ Input Rise and Fall Time	–	–	500	μs
t <sub>PU</sub> (Note 8)	Power-up to Wiper Stable	–	–	1	ms
t <sub>WR</sub>	Store Cycle	–	5	10	ms

7. Typical values are for T<sub>A</sub> = 25°C and nominal supply voltage.

8. This parameter is periodically sampled and not 100% tested.

9. MI in the A.C. Timing diagram refers to the minimum incremental change in the W output due to a change in the wiper position.

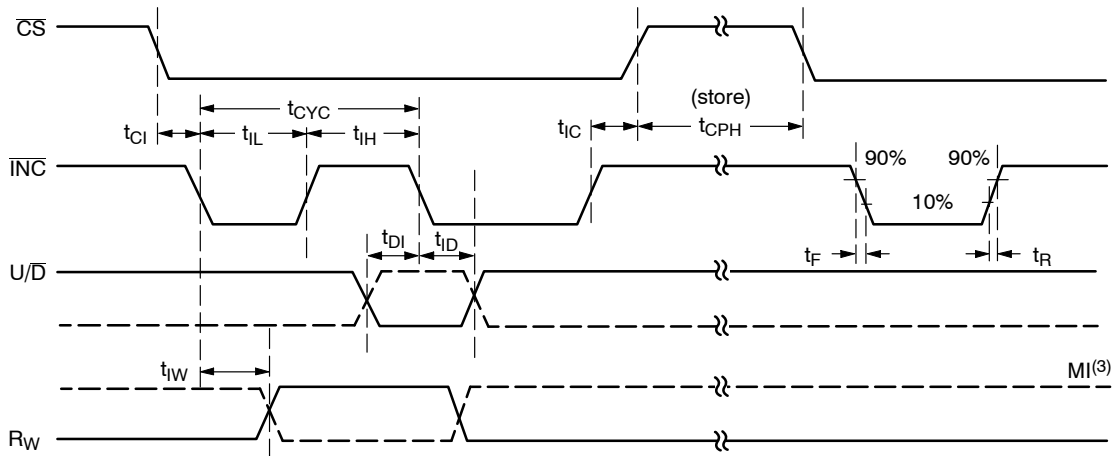
**Figure 5. A.C. Timing**

# CAT5114

## APPLICATIONS INFORMATION

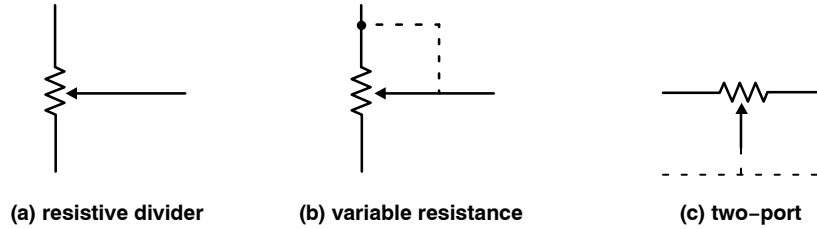

Figure 6. Potentiometer Configuration

### Applications

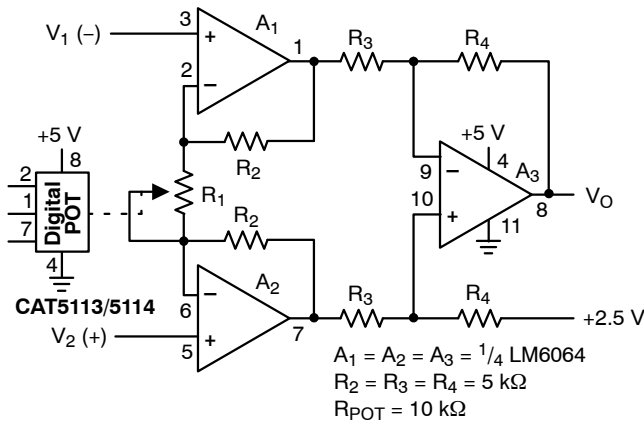

Figure 7. Programmable Instrumentation Amplifier

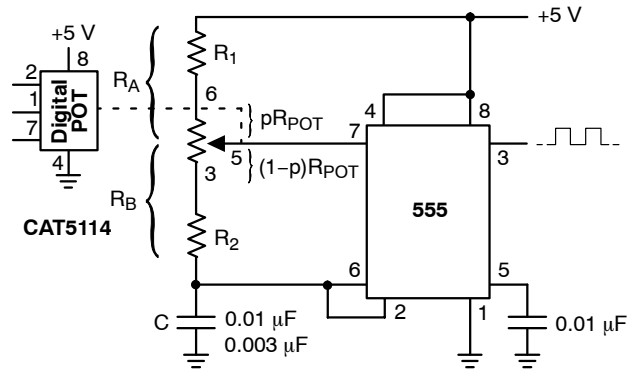

Figure 8. Programmable Sq. Wave Oscillator (555)

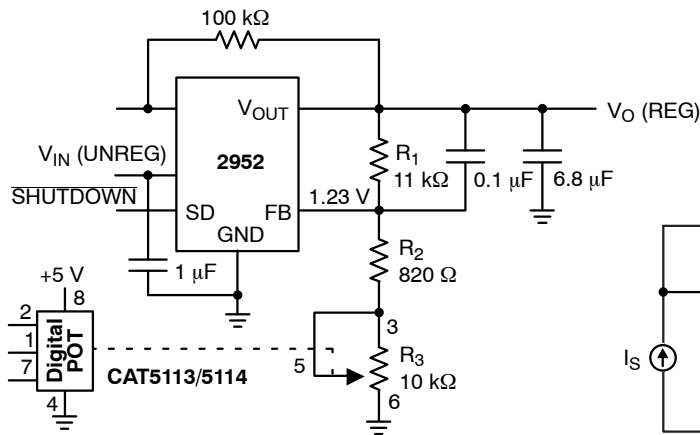

Figure 9. Programmable Voltage Regulator

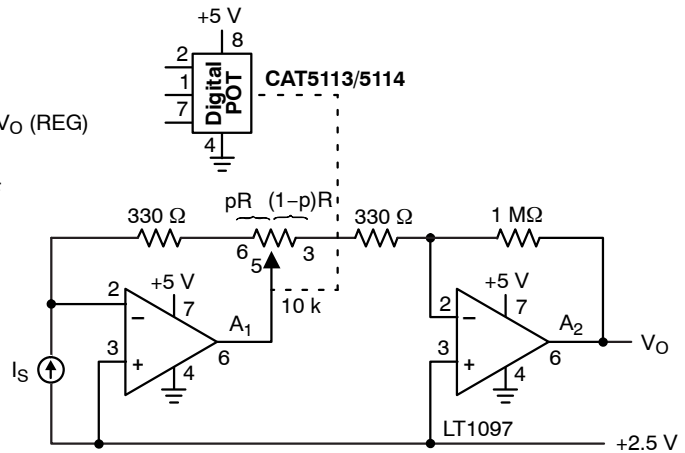

Figure 10. Programmable I to V Converter



**CAT5114****Table 8. ORDERING INFORMATION**

Orderable Part Numbers	Resistance Values (k $\Omega$ )	Package–Pin	Lead Finish	Shipping†
CAT5114LI–10–G	10	PDIP–8	NiPdAu	50 Units / Rail
CAT5114LI–50–G	50			
CAT5114LI–00–G	100			
CAT5114VI–10–GT3	10	SOIC–8	NiPdAu	100 Units / Rail
CAT5114VI–50–GT3	50			
CAT5114VI–00–GT3	100			
CAT5114VP2I10GT3 (Notes 10, 11)	10	TDFN–8 2 x 3 mm	NiPdAu	3000 / Tape & Reel
CAT5114VP2I50GT3 (Notes 10, 11)	50			
CAT5114VP2I00GT3 (Notes 10, 11)	100			
CAT5114YI–10–GT3	10	TSSOP–8	NiPdAu	3000 / Tape & Reel
CAT5114YI–50–GT3	50			
CAT5114YI–00–GT3	100			
CAT5114ZI–10–GT3	10	MSOP–8	NiPdAu	96 Units / Rail
CAT5114ZI–50–GT3	50			
CAT5114ZI–00–GT3	100			

†For information on tape and reel specifications, including part orientation and tape sizes, please refer to our Tape and Reel Packaging Specifications Brochure, BRD8011/D.

10. Contact factory for package availability.

11. Part number is not exactly the same as the “Example of Ordering Information” shown above. For the indicated part numbers there are NO hyphens in the orderable part numbers.

12. All packages are RoHS-compliant (Pb-Free, Halogen-Free).

13. The standard lead finish is NiPdAu.

14. For additional package and temperature options, please contact your nearest ON Semiconductor Sales office.

# CAT5114

## PACKAGE DIMENSIONS

PDIP-8, 300 mils  
CASE 646AA  
ISSUE A

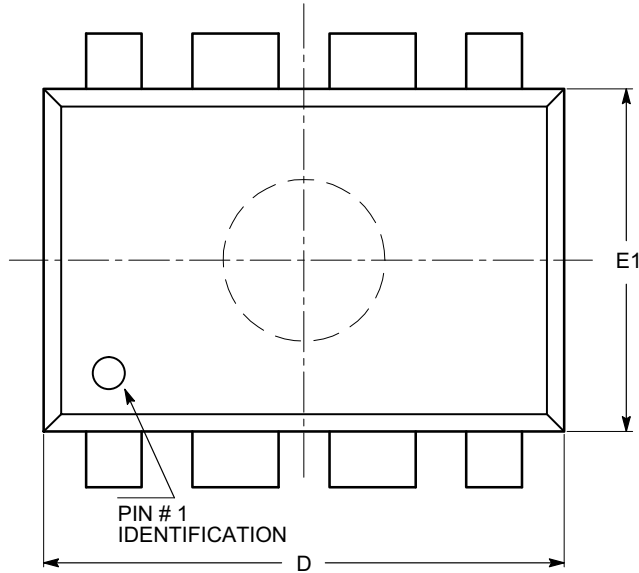

SYMBOL	MIN	NOM	MAX
A			5.33
A1	0.38		
A2	2.92	3.30	4.95
b	0.36	0.46	0.56
b2	1.14	1.52	1.78
c	0.20	0.25	0.36
D	9.02	9.27	10.16
E	7.62	7.87	8.25
E1	6.10	6.35	7.11
e	2.54 BSC		
eB	7.87		10.92
L	2.92	3.30	3.80

TOP VIEW

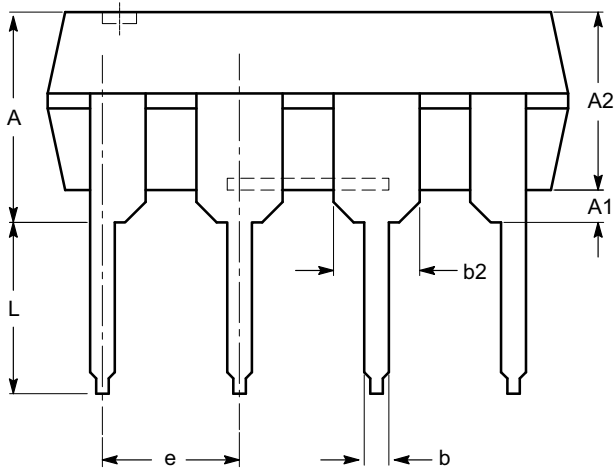

SIDE VIEW

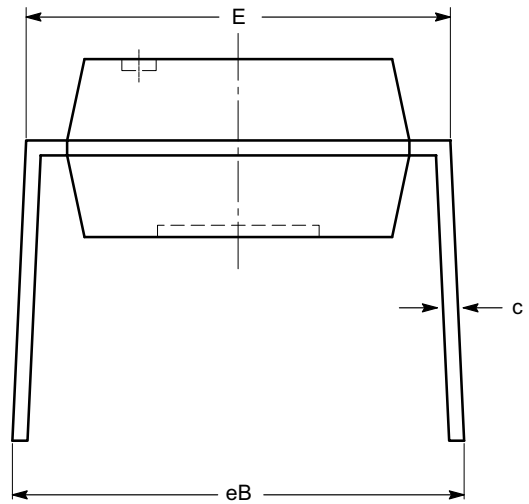

END VIEW

**Notes:**

- (1) All dimensions are in millimeters.
- (2) Complies with JEDEC MS-001.

**CAT5114****PACKAGE DIMENSIONS**

**SOIC 8, 150 mils**  
**CASE 751BD**  
**ISSUE O**

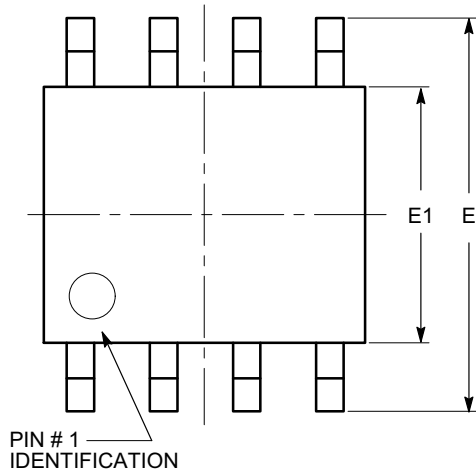
**TOP VIEW**

SYMBOL	MIN	NOM	MAX
A	1.35		1.75
A1	0.10		0.25
b	0.33		0.51
c	0.19		0.25
D	4.80		5.00
E	5.80		6.20
E1	3.80		4.00
e	1.27 BSC		
h	0.25		0.50
L	0.40		1.27
$\theta$	0°		8°

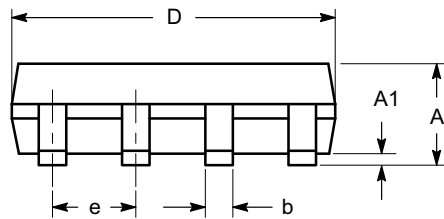
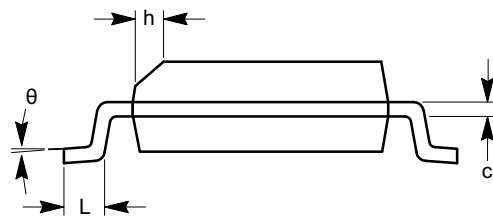
**SIDE VIEW****END VIEW****Notes:**

- (1) All dimensions are in millimeters. Angles in degrees.
- (2) Complies with JEDEC MS-012.

# CAT5114

## PACKAGE DIMENSIONS

MSOP 8, 3x3  
CASE 846AD  
ISSUE O

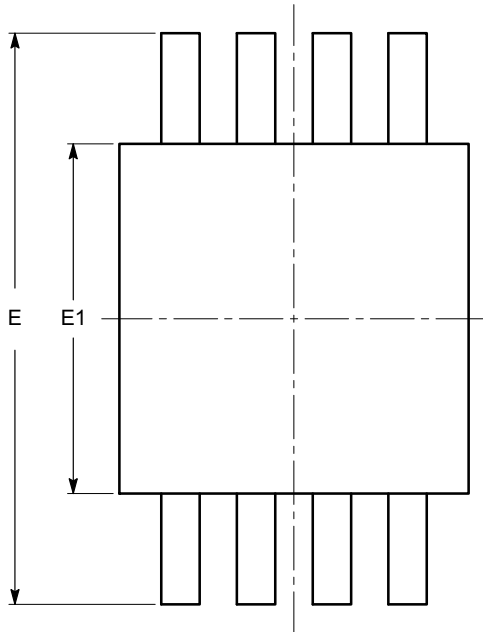

TOP VIEW

SYMBOL	MIN	NOM	MAX
A			1.10
A1	0.05	0.10	0.15
A2	0.75	0.85	0.95
b	0.22		0.38
c	0.13		0.23
D	2.90	3.00	3.10
E	4.80	4.90	5.00
E1	2.90	3.00	3.10
e	0.65 BSC		
L	0.40	0.60	0.80
L1	0.95 REF		
L2	0.25 BSC		
$\theta$	0°		6°

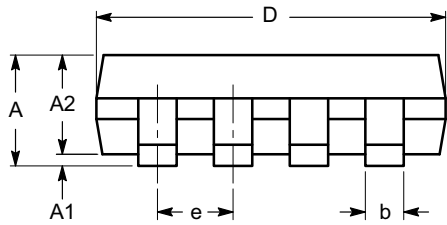

SIDE VIEW

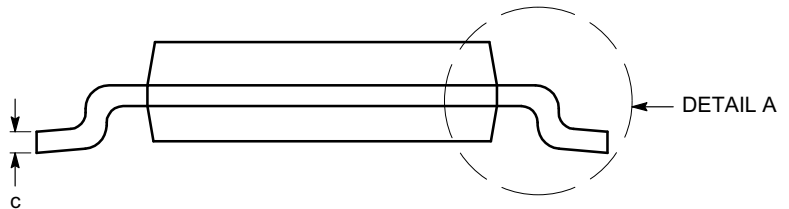

END VIEW

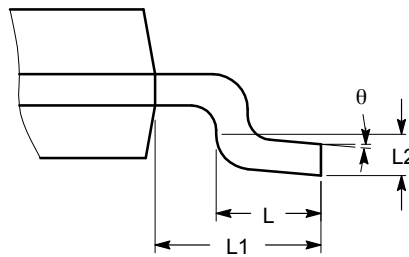

DETAIL A

**Notes:**

- (1) All dimensions are in millimeters. Angles in degrees.
- (2) Complies with JEDEC MO-187.

# CAT5114

## PACKAGE DIMENSIONS

TSSOP8, 4.4x3  
 CASE 948AL  
 ISSUE O

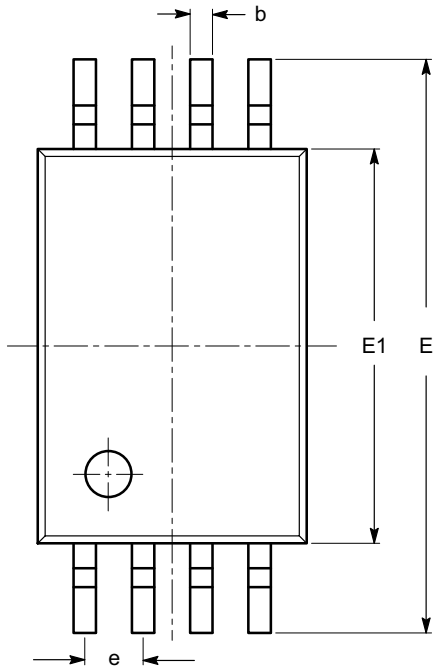

SYMBOL	MIN	NOM	MAX
A			1.20
A1	0.05		0.15
A2	0.80	0.90	1.05
b	0.19		0.30
c	0.09		0.20
D	2.90	3.00	3.10
E	6.30	6.40	6.50
E1	4.30	4.40	4.50
e	0.65 BSC		
L	1.00 REF		
L1	0.50	0.60	0.75
$\theta$	0°		8°

TOP VIEW

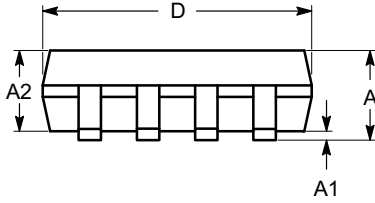

SIDE VIEW

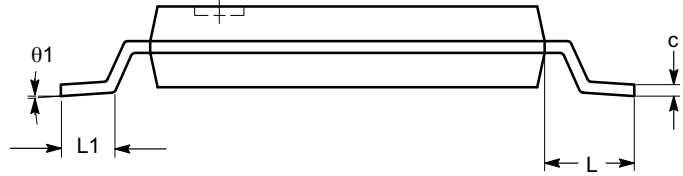

END VIEW

**Notes:**

- (1) All dimensions are in millimeters. Angles in degrees.
- (2) Complies with JEDEC MO-153.

# CAT5114

## PACKAGE DIMENSIONS

TDFN8, 2x3  
CASE 511AK  
ISSUE A

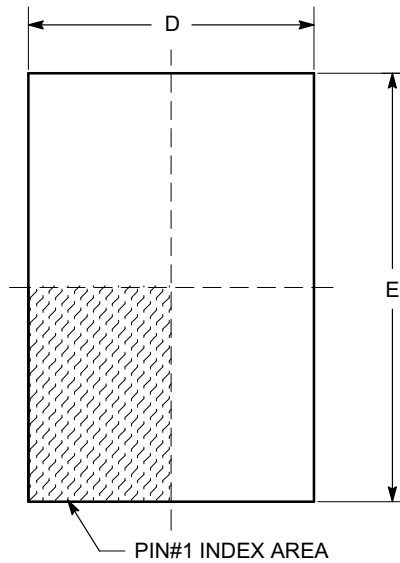

TOP VIEW

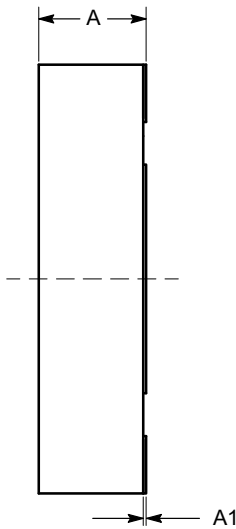

SIDE VIEW

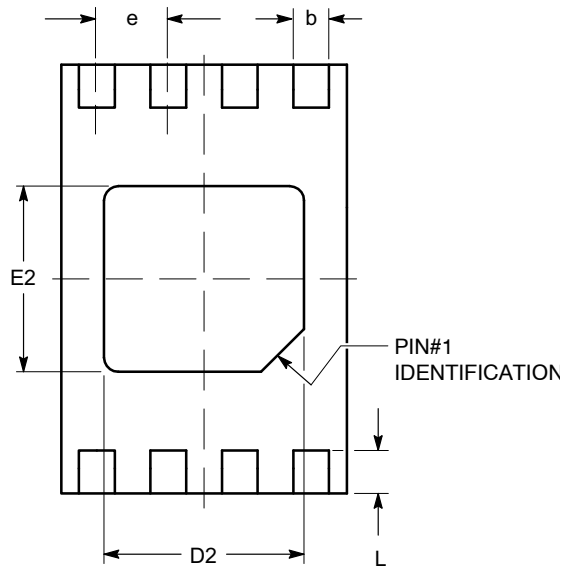

BOTTOM VIEW

SYMBOL	MIN	NOM	MAX
A	0.70	0.75	0.80
A1	0.00	0.02	0.05
A2	0.45	0.55	0.65
A3	0.20 REF		
b	0.20	0.25	0.30
D	1.90	2.00	2.10
D2	1.30	1.40	1.50
E	2.90	3.00	3.10
E2	1.20	1.30	1.40
e	0.50 TYP		
L	0.20	0.30	0.40

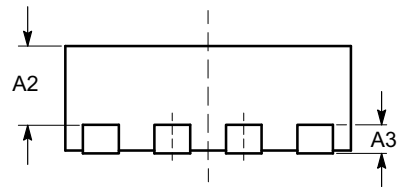

FRONT VIEW

**Notes:**

- (1) All dimensions are in millimeters.
- (2) Complies with JEDEC MO-229.

**CAT5114**

**onsemi**, **Onsemi**, and other names, marks, and brands are registered and/or common law trademarks of Semiconductor Components Industries, LLC dba "**onsemi**" or its affiliates and/or subsidiaries in the United States and/or other countries. **onsemi** owns the rights to a number of patents, trademarks, copyrights, trade secrets, and other intellectual property. A listing of **onsemi**'s product/patent coverage may be accessed at [www.onsemi.com/site/pdf/Patent-Marking.pdf](http://www.onsemi.com/site/pdf/Patent-Marking.pdf). **onsemi** reserves the right to make changes at any time to any products or information herein, without notice. The information herein is provided "as-is" and **onsemi** makes no warranty, representation or guarantee regarding the accuracy of the information, product features, availability, functionality, or suitability of its products for any particular purpose, nor does **onsemi** assume any liability arising out of the application or use of any product or circuit, and specifically disclaims any and all liability, including without limitation special, consequential or incidental damages. Buyer is responsible for its products and applications using **onsemi** products, including compliance with all laws, regulations and safety requirements or standards, regardless of any support or applications information provided by **onsemi**. "Typical" parameters which may be provided in **onsemi** data sheets and/or specifications can and do vary in different applications and actual performance may vary over time. All operating parameters, including "Typicals" must be validated for each customer application by customer's technical experts. **onsemi** does not convey any license under any of its intellectual property rights nor the rights of others. **onsemi** products are not designed, intended, or authorized for use as a critical component in life support systems or any FDA Class 3 medical devices or medical devices with a same or similar classification in a foreign jurisdiction or any devices intended for implantation in the human body. Should Buyer purchase or use **onsemi** products for any such unintended or unauthorized application, Buyer shall indemnify and hold **onsemi** and its officers, employees, subsidiaries, affiliates, and distributors harmless against all claims, costs, damages, and expenses, and reasonable attorney fees arising out of, directly or indirectly, any claim of personal injury or death associated with such unintended or unauthorized use, even if such claim alleges that **onsemi** was negligent regarding the design or manufacture of the part. **onsemi** is an Equal Opportunity/Affirmative Action Employer. This literature is subject to all applicable copyright laws and is not for resale in any manner.

**PUBLICATION ORDERING INFORMATION****LITERATURE FULFILLMENT:**Email Requests to: [orderlit@onsemi.com](mailto:orderlit@onsemi.com)**onsemi Website:** [www.onsemi.com](http://www.onsemi.com)**TECHNICAL SUPPORT****North American Technical Support:**

Voice Mail: 1 800-282-9855 Toll Free USA/Canada

Phone: 011 421 33 790 2910

**Europe, Middle East and Africa Technical Support:**

Phone: 00421 33 790 2910

For additional information, please contact your local Sales Representative

## OUR CERTIFICATE

DiGi provide top-quality products and perfect service for customer worldwide through standardization, technological innovation and continuous improvement. DiGi through third-party certification, we stricly control the quality of products and services. Welcome your RFQ to

Email: [Info@DiGi-Electronics.com](mailto:Info@DiGi-Electronics.com)



Tel: +00 852-30501935

RFQ Email: [Info@DiGi-Electronics.com](mailto:Info@DiGi-Electronics.com)

DiGi is a global authorized distributor of electronic components.