

# FIN1001M5 Datasheet

[www.digi-electronics.com](http://www.digi-electronics.com)

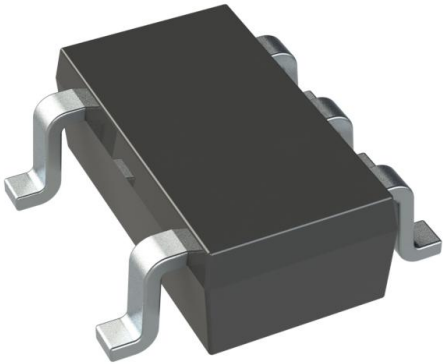

<https://www.DiGi-Electronics.com>

DiGi Electronics Part Number	FIN1001M5-DG
Manufacturer	<a href="#">onsemi</a>
Manufacturer Product Number	FIN1001M5
Description	IC DRIVER 1/0 SOT23-5
Detailed Description	1/0 Driver LVDS SOT-23-5



Tel: +00 852-30501935

RFQ Email: [Info@DiGi-Electronics.com](mailto:Info@DiGi-Electronics.com)

DiGi is a global authorized distributor of electronic components.

## Purchase and inquiry

Manufacturer Product Number:

FIN1001M5

Series:

-

Type:

Driver

Number of Drivers/Receivers:

1/0

Data Rate:

600Mbps

Operating Temperature:

-40°C ~ 85°C

Package / Case:

SC-74A, SOT-753

Base Product Number:

FIN1001

Manufacturer:

onsemi

Product Status:

Obsolete

Protocol:

LVDS

Duplex:

-

Voltage - Supply:

3V ~ 3.6V

Mounting Type:

Surface Mount

Supplier Device Package:

SOT-23-5

## Environmental & Export classification

Moisture Sensitivity Level (MSL):

1 (Unlimited)

ECCN:

EAR99

REACH Status:

REACH Unaffected

HTSUS:

8542.39.0001





December 2001  
Revised August 2004

## FIN1001

### 3.3V LVDS 1-Bit High Speed Differential Driver

#### General Description

This single driver is designed for high speed interconnects utilizing Low Voltage Differential Signaling (LVDS) technology. The driver translates LVTTTL signal levels to LVDS levels with a typical differential output swing of 350 mV which provides low EMI at ultra low power dissipation even at high frequencies. This device is ideal for high speed transfer of clock or data.

The FIN1001 can be paired with its companion receiver, the FIN1002, or with any other LVDS receiver.

#### Features

- Greater than 600Mbps data rate
- 3.3V power supply operation
- 0.5ns maximum differential pulse skew
- 1.5ns maximum propagation delay
- Low power dissipation
- Power-Off protection
- Meets or exceeds the TIA/EIA-644 LVDS standard
- Flow-through pinout simplifies PCB layout
- 5-Lead SOT23 package saves space

#### Ordering Code:

Order Number	Package Number	Package Description
FIN1001M5	MA05B	5-Lead SOT23, JEDEC MO-178, 1.6mm [250 Units on Tape and Reel]
FIN1001M5X	MA05B	5-Lead SOT23, JEDEC MO-178, 1.6mm [3000 Units on Tape and Reel]

#### Pin Descriptions

Pin Name	Description
D <sub>IN</sub>	LVTTTL Data Input
D <sub>OUT+</sub>	Non-inverting LVDS Driver Output
D <sub>OUT-</sub>	Inverting LVDS Driver Output
V <sub>CC</sub>	Power Supply
GND	Ground
NC	No Connect

#### Function Table

Input	Outputs	
D <sub>IN</sub>	D <sub>OUT+</sub>	D <sub>OUT-</sub>
L	L	H
H	H	L

H = HIGH Logic Level      L = LOW Logic Level

#### Connection Diagram

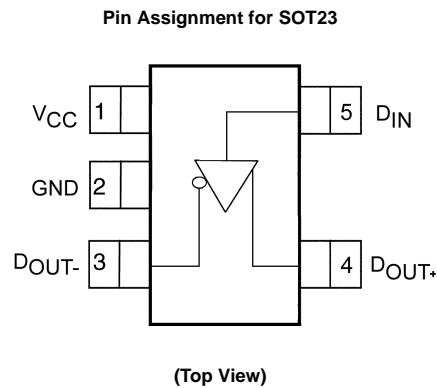

FIN1001 3.3V LVDS 1-Bit High Speed Differential Driver

FIN1001

**Absolute Maximum Ratings** (Note 1)

Supply Voltage ( $V_{CC}$ )	-0.5V to +4.6V
DC Input Voltage ( $D_{IN}$ )	-0.5V to +6V
DC Output Voltage ( $D_{OUT}$ )	-0.5V to +4.6V
Driver Short Circuit Current ( $I_{OSD}$ )	Continuous
Storage Temperature Range ( $T_{STG}$ )	-65°C to +150°C
Max Junction Temperature ( $T_J$ )	150°C
Lead Temperature ( $T_L$ ) (Soldering, 10 seconds)	260°C
ESD (Human Body Model)	≥ 7500V
ESD (Machine Model)	≥ 400V

**Recommended Operating Conditions**

Supply Voltage ( $V_{CC}$ )	3.0V to 3.6V
Input Voltage ( $V_{IN}$ )	0 to $V_{CC}$
Operating Temperature ( $T_A$ )	-40°C to +85°C

**Note 1:** The "Absolute Maximum Ratings" are those values beyond which damage to the device may occur. The databook specifications should be met, without exception, to ensure that the system design is reliable over its power supply, temperature and output/input loading variables. Fairchild does not recommend operation of circuits outside databook specification.

**DC Electrical Characteristics**

Over supply voltage and operating temperature ranges, unless otherwise specified

Symbol	Parameter	Test Conditions	Min	Typ (Note 2)	Max	Units
$V_{OD}$	Output Differential Voltage	$R_L = 100 \Omega$ , See Figure 1	250	350	450	mV
$\Delta V_{OD}$	$V_{OD}$ Magnitude Change from Differential LOW-to-HIGH				25	mV
$V_{OS}$	Offset Voltage		1.125	1.25	1.375	V
$\Delta V_{OS}$	Offset Magnitude Change from Differential LOW-to-HIGH				25	mV
$I_{OFF}$	Power-Off Output Current	$V_{CC} = 0V$ , $V_{OUT} = 0V$ or 3.6V			±20	μA
$I_{OS}$	Short Circuit Output Current	$V_{OUT} = 0V$		-5.5	-8	mA
		$V_{OD} = 0V$		±4	±8	
$V_{IH}$	Input HIGH Voltage		2.0		$V_{CC}$	V
$V_{IL}$	Input LOW Voltage		GND		0.8	V
$I_{IN}$	Input Current	$V_{IN} = 0V$ or $V_{CC}$			±20	μA
$I_{I(OFF)}$	Power-Off Input Current	$V_{CC} = 0V$ , $V_{IN} = 0V$ or 3.6V			±20	μA
$V_{IK}$	Input Clamp Voltage	$I_{IK} = -18$ mA	-1.5	-0.8		V
$I_{CC}$	Power Supply Current	No Load, $V_{IN} = 0V$ or $V_{CC}$		4.5	8	mA
		$R_L = 100 \Omega$ , $V_{IN} = 0V$ or $V_{CC}$		6.5	10	
$C_{IN}$	Input Capacitance	$V_{CC} = 3.3V$		3.2		pF
$C_{OUT}$	Output Capacitance	$V_{CC} = 0V$		3.3		pF

**Note 2:** All typical values are at  $T_A = 25^\circ\text{C}$  and with  $V_{CC} = 3.3V$ .

**AC Electrical Characteristics**

Over supply voltage and operating temperature ranges, unless otherwise specified

Symbol	Parameter	Test Conditions	Min	Typ (Note 3)	Max	Units	
$t_{PLHD}$	Differential Propagation Delay LOW-to-HIGH	$R_L = 100 \Omega$ , $C_L = 10\text{pF}$ , See Figure 2 and Figure 3	0.5	0.98	1.5	ns	
$t_{PHLD}$	Differential Propagation Delay HIGH-to-LOW		0.5	0.93	1.5	ns	
$t_{TLHD}$	Differential Output Rise Time (20% to 80%)		0.4	0.5	1.0	ns	
$t_{THLD}$	Differential Output Fall Time (80% to 20%)		0.4	0.5	1.0	ns	
$t_{SK(P)}$	Pulse Skew $ t_{PLH} - t_{PHL} $				0.05	0.5	ns
$t_{SK(PP)}$	Part-to-Part Skew (Note 4)					1.0	ns

**Note 3:** All typical values are at  $T_A = 25^\circ\text{C}$  and with  $V_{CC} = 3.3V$ .

**Note 4:**  $t_{SK(PP)}$  is the magnitude of the difference in propagation delay times between any specified terminals of two devices switching in the same direction (either LOW-to-HIGH or HIGH-to-LOW) when both devices operate with the same supply voltage, same temperature, and have identical test circuits.

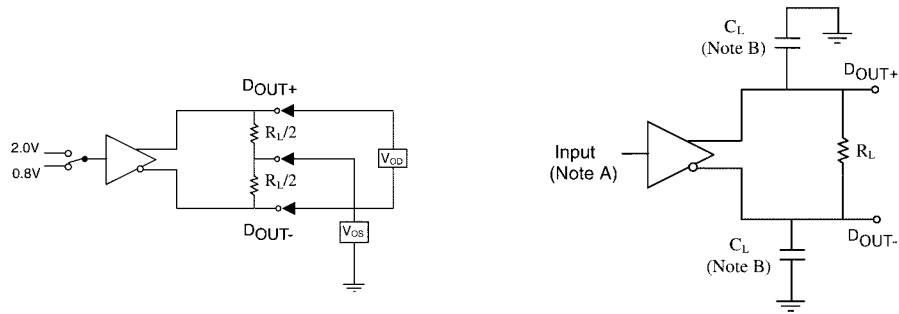

**Note A:** All input pulses have frequency = 10 MHz,  $t_r$  or  $t_f = 2$  ns  
**Note B:**  $C_L$  includes all probe and fixture capacitances

**FIGURE 1. Differential Driver DC Test Circuit**

**FIGURE 2. Differential Driver Propagation Delay and Transition Time Test Circuit**

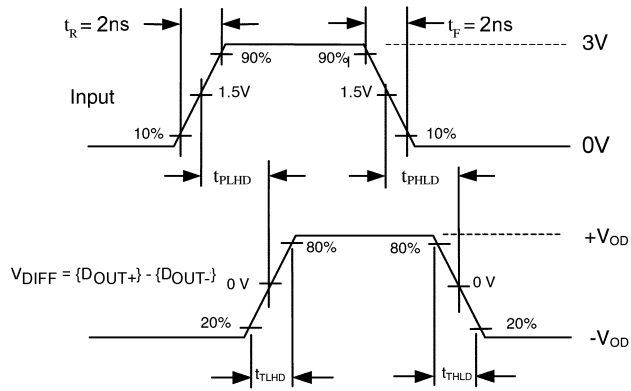

**FIGURE 3. AC Waveforms**

FIN1001

DC / AC Typical Performance Curves

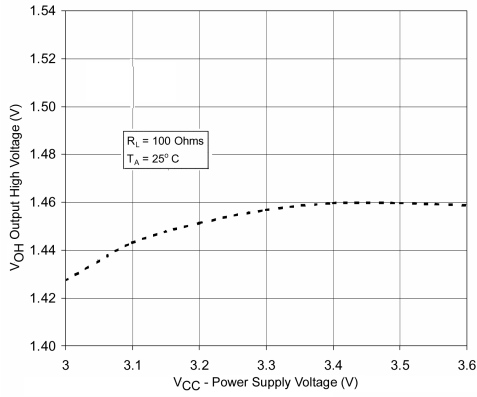

FIGURE 4. Output High Voltage vs. Power Supply Voltage

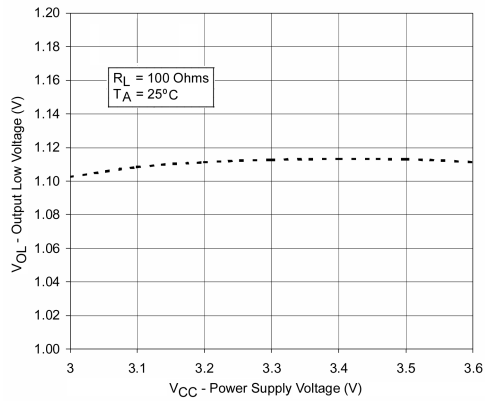

FIGURE 5. Output Low Voltage vs. Power Supply Voltage

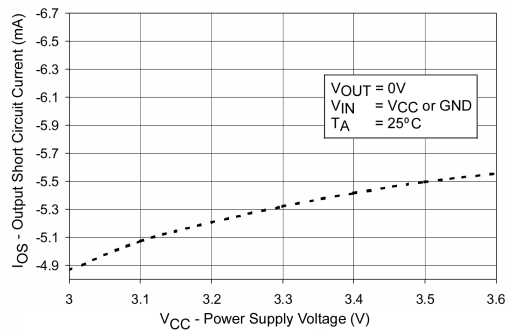

FIGURE 6. Output Short Circuit Current vs. Power Supply Voltage

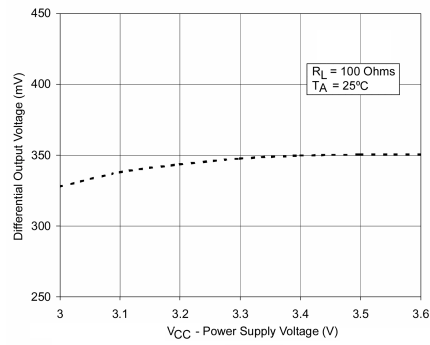

FIGURE 7. Differential Output Voltage vs. Power Supply Voltage

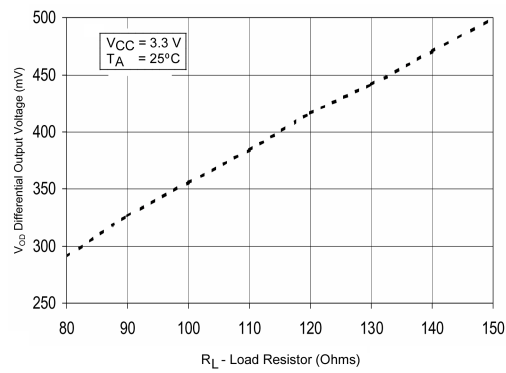

FIGURE 8. Differential Output Voltage vs. Load Resistor

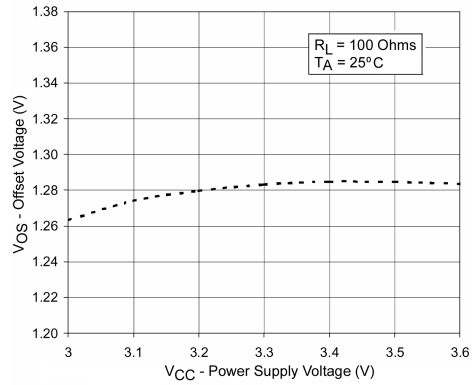
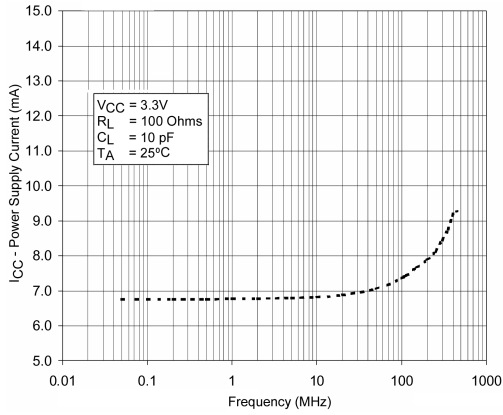
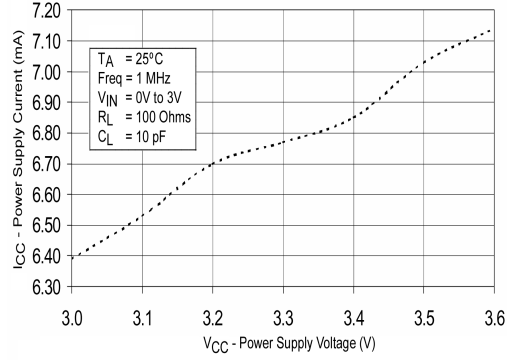

FIGURE 9. Offset Voltage vs. Power Supply Voltage

**DC / AC Typical Performance Curves** (Continued)



**FIGURE 10. Power Supply Current vs. Frequency**



**FIGURE 11. Power Supply Current vs. Power Supply Voltage**

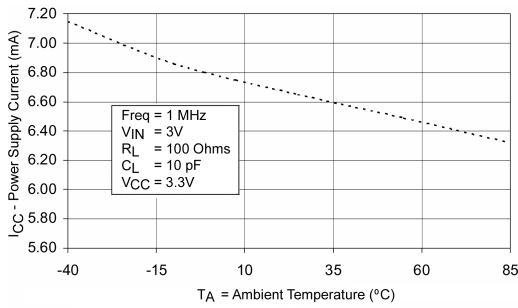

**FIGURE 12. Power Supply Current vs. Ambient Temperature**

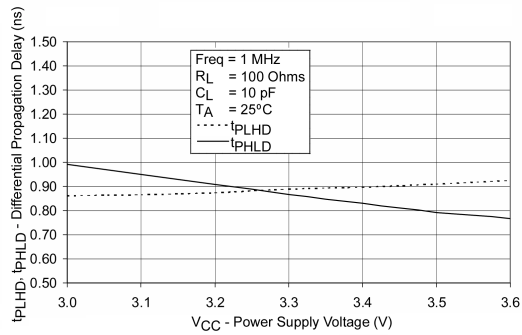

**FIGURE 13. Differential Propagation Delay vs. Power Supply**

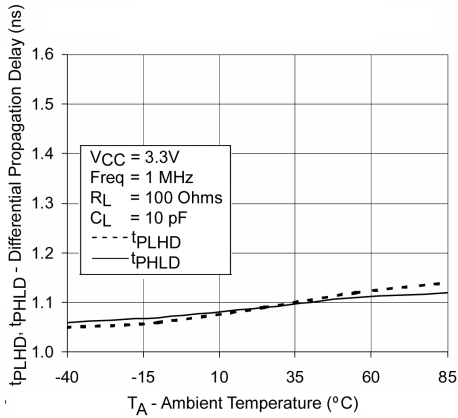

**FIGURE 14. Differential Propagation Delay vs. Ambient Temperature**

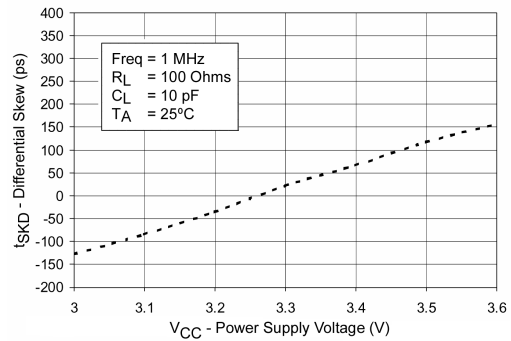

**FIGURE 15. Differential Pulse Skew ( $t_{PLH} - t_{PHL}$ ) vs. Power Supply Voltage**

FIN1001

DC / AC Typical Performance Curves (Continued)

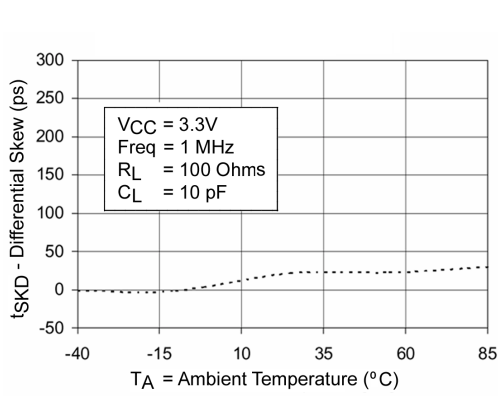

FIGURE 16. Differential Pulse Skew ( $t_{PLH} - t_{PHL}$ ) vs. Ambient Temperature

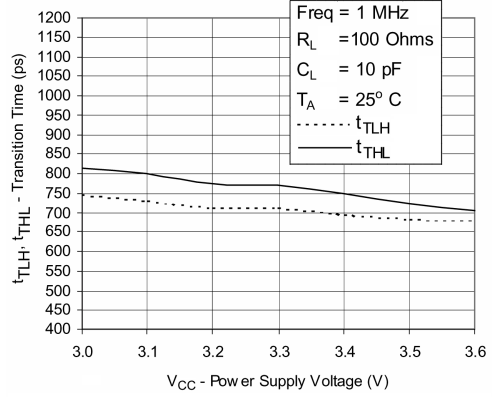

FIGURE 17. Transition Time vs. Power Supply Voltage

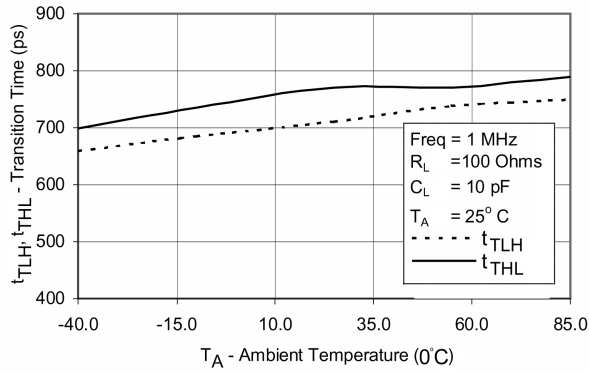
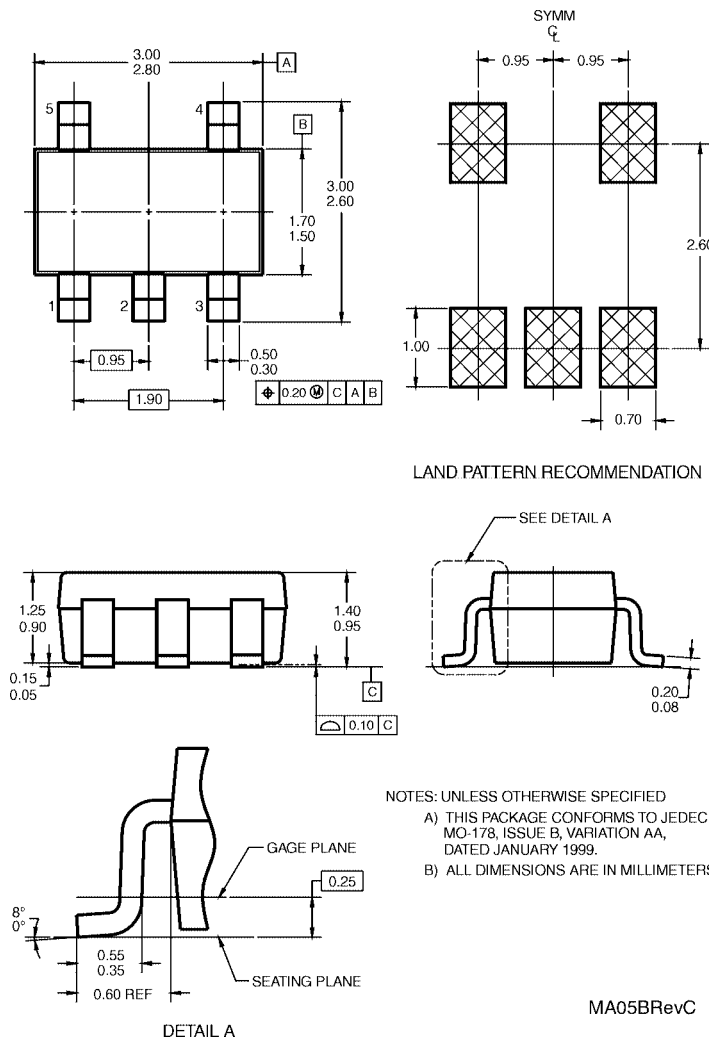

FIGURE 18. Transition Time vs. Ambient Temperature



**Physical Dimensions** inches (millimeters) unless otherwise noted



**5-Lead SOT23, JEDEC MO-178, 1.6mm  
 Package Number MA05B**

Fairchild does not assume any responsibility for use of any circuitry described, no circuit patent licenses are implied and Fairchild reserves the right at any time without notice to change said circuitry and specifications.

**LIFE SUPPORT POLICY**

FAIRCHILD'S PRODUCTS ARE NOT AUTHORIZED FOR USE AS CRITICAL COMPONENTS IN LIFE SUPPORT DEVICES OR SYSTEMS WITHOUT THE EXPRESS WRITTEN APPROVAL OF THE PRESIDENT OF FAIRCHILD SEMICONDUCTOR CORPORATION. As used herein:

1. Life support devices or systems are devices or systems which, (a) are intended for surgical implant into the body, or (b) support or sustain life, and (c) whose failure to perform when properly used in accordance with instructions for use provided in the labeling, can be reasonably expected to result in a significant injury to the user.
2. A critical component in any component of a life support device or system whose failure to perform can be reasonably expected to cause the failure of the life support device or system, or to affect its safety or effectiveness.

[www.fairchildsemi.com](http://www.fairchildsemi.com)

## OUR CERTIFICATE

DiGi provide top-quality products and perfect service for customer worldwide through standardization, technological innovation and continuous improvement. DiGi through third-party certification, we stricly control the quality of products and services. Welcome your RFQ to

Email: [Info@DiGi-Electronics.com](mailto:Info@DiGi-Electronics.com)



Tel: +00 852-30501935

RFQ Email: [Info@DiGi-Electronics.com](mailto:Info@DiGi-Electronics.com)

DiGi is a global authorized distributor of electronic components.