

# FOD8342R2V Datasheet

[www.digi-electronics.com](http://www.digi-electronics.com)



<https://www.DiGi-Electronics.com>

DiGi Electronics Part Number	FOD8342R2V-DG
Manufacturer	<a href="#">onsemi</a>
Manufacturer Product Number	FOD8342R2V
Description	OPTOISO 5KV 1CH GATE DVR 6SOP
Detailed Description	3A Gate Driver Optical Coupling 5000Vrms 1 Channel 6-SOP

This model FOD8342R2V is available at DiGi Electronics.

DiGi Electronics offers a global database of semiconductor and electronic component datasheets.

We welcome your inquiries regarding pricing, lead time, or other product-related questions.

 [Request a Quote](#)

 [Datasheet Search](#)



Tel: +00 852-30501935

RFQ Email: [Info@DiGi-Electronics.com](mailto:Info@DiGi-Electronics.com)

DiGi is a global authorized distributor of electronic components.

## Purchase and inquiry

Manufacturer Product Number:

FOD8342R2V

Series:

-

Technology:

Optical Coupling

Voltage - Isolation:

5000Vrms

Propagation Delay tpLH / tpHL (Max):

210ns, 210ns

Rise / Fall Time (Typ):

38ns, 24ns

Current - Peak Output:

3A

Current - DC Forward (If) (Max):

25 mA

Grade:

-

Mounting Type:

Surface Mount

Supplier Device Package:

6-SOP

Base Product Number:

FOD8342

Manufacturer:

onsemi

Product Status:

Active

Number of Channels:

1

Common Mode Transient Immunity (Min):

20kV/ $\mu$ s

Pulse Width Distortion (Max):

65ns

Current - Output High, Low:

2.5A, 2.5A

Voltage - Forward (Vf) (Typ):

1.5V

Voltage - Output Supply:

10V ~ 30V

Operating Temperature:

-40°C ~ 100°C

Package / Case:

6-SOIC (0.268", 6.80mm Width)

Approval Agency:

UL

## Environmental & Export classification

RoHS Status:

ROHS3 Compliant

REACH Status:

REACH Unaffected

HTSUS:

8541.49.8000

Moisture Sensitivity Level (MSL):

1 (Unlimited)

ECCN:

EAR99

# 3.0 A Output Current, High Speed Gate Drive Optocoupler in Stretched Body SOP 6-Pin

## FOD8342, FOD8342T

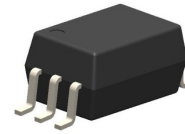

SOIC6  
CASE 751EL

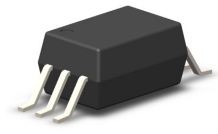

SOIC6 W  
CASE 751EM

### Description

The FOD8342 series is a 3.0 A output current gate drive optocoupler, capable of driving medium-power IGBT/ MOSFETs. It is ideally suited for fast-switching driving of power IGBT and MOSFET used in motor-control inverter applications, and high-performance power systems.

The FOD8342 series utilizes stretched body package to achieve 8 mm creepage and clearance distances (FOD8342T), and optimized IC design to achieve reliably high-insulation voltage and high-noise immunity.

The FOD8342 series consists of an Aluminum Gallium Arsenide (AlGaAs) Light-Emitting Diode (LED) optically coupled to an integrated circuit with a high-speed driver for push-pull MOSFET output stage. The device is housed in a stretched body, 6-pin, small outline, plastic package.

### Features

- FOD8342T – 8 mm Creepage and Clearance Distance, and 0.4 mm Insulation Distance to Achieve Reliable and High-Voltage Insulation
- 3.0 A Peak Output Current Driving Capability for Medium-Power IGBT/MOSFET
  - ◆ Use of P-Channel MOSFETs at Output Stage Enables Output Voltage Swing Close to Supply Rail
- 20 kV/μs Minimum Common Mode Rejection
- Wide Supply Voltage Range: 10 V to 30 V
- Fast Switching Speed Over Full Operating Temperature Range
  - ◆ 210 ns Maximum Propagation Delay
  - ◆ 65 ns Maximum Pulse Width Distortion
- Under-Voltage Lockout (UVLO) with Hysteresis
- Extended Industrial Temperature Range: -40°C to 100°C
- Safety and Regulatory Approvals:
  - ◆ UL1577, 5,000 V<sub>RMS</sub> for 1 Minute
  - ◆ DIN EN/IEC60747-5-5, 1,140V Peak Working Insulation Voltage

### Applications

- AC and Brushless DC Motor Drives
- Industrial Inverter
- Uninterruptible Power Supply
- Induction Heating
- Isolated IGBT/Power MOSFET Gate Drive

### MARKING DIAGRAM

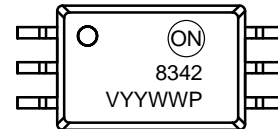

8342	=	Specific Device Number
V	=	DIN EN/IEC60747-5-5 Option
YY	=	Two Digit Year Code
WW	=	Two Digit Work Week
P	=	Assembly Package Code

### FUNCTIONAL SCHEMATIC

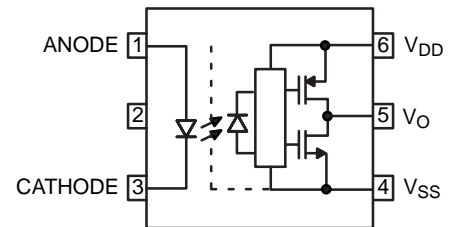

### ORDERING INFORMATION

See detailed ordering, marking and shipping information in the package dimensions section on page 18 of this data sheet.

NOTE: Some of the devices on this data sheet have been **DISCONTINUED**. Please refer to the table on page 18.

### Related Resources

- [FOD3182, 3 A Output Current, High Speed MOSFET Gate Drive Optocoupler](#)
- [FOD8314, FOD8314T, 1.0 A Output Current, Gate Drive Optocoupler in Stretched Body SOP 6-Pin](#)
- [www.onsemi.com](http://www.onsemi.com)

**FOD8342, FOD8342T****Table 1. TRUTH TABLE**

LED	$V_{DD} - V_{SS}$ "Positive Going" (Turn-On)	$V_{DD} - V_{SS}$ "Negative Going" (Turn-Off)	$V_O$
Off	0 V to 30 V	0 V to 30 V	LOW
On	0 V to 7 V	0 V to 6.5 V	LOW
On	7 V to 9.5 V	6.5 V to 9 V	Transition
On	9.5 V to 30 V	9 V to 30 V	HIGH

**Table 2. PIN DESCRIPTION**

Pin No.	Name	Description
1	ANODE	LED Anode
2	N.C	Not Connection
3	CATHODE	LED Cathode
4	$V_{SS}$	Negative Supply Voltage
5	$V_O$	Output Voltage
6	$V_{DD}$	Positive Supply Voltage

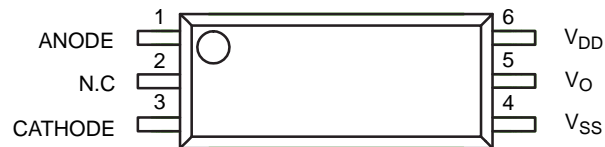
**Pin Configuration****Figure 1. Pin Configuration**

**FOD8342, FOD8342T****Table 3. SAFETY AND INSULATION RATINGS**

As per DIN\_EN/IEC60747-5-5. This optocoupler is suitable for "safe electrical insulation" only within the safety limit data. Compliance with the safety ratings shall be ensured by means of protective circuits.

Parameter	Symbol	FOD8342	FOD8342T	Unit
Installation Classifications per DIN VDE 0110/1.89 Table 1, For Rated Main Voltage	<150 Vrms		I-IV	
	<300 Vrms		I-IV	
	<450 Vrms		I-III	
	<600 Vrms		I-III	
Climatic Classification		40/100/21	40/100/21	
Pollution Degree (DIN VDE 0110/1.89)		2	2	
Comparative Tracking Index	CTI	175	175	
Input to Output Test Voltage, Method B, $V_{IORM} \times 1.875 = V_{PR}$ , 100% Production Test with $t_m = 1$ sec, Partial Discharge <5 pC	$V_{PR}$	1,671	2,137	$V_{peak}$
Input to Output Test Voltage, Method A, $V_{IORM} \times 1.6 = V_{PR}$ , Type and Sample Test with $t_m = 10$ sec, Partial Discharge <5 pC		1,426	1,824	$V_{peak}$
Max Working Insulation Voltage	$V_{IORM}$	891	1,140	$V_{peak}$
Highest Allowable Over Voltage	$V_{IOTM}$	6,000	8,000	$V_{peak}$
External Creepage		≥8.0	≥8.0	mm
External Clearance		≥7.0	≥8.0	mm
Distance Through Insulation (Insulation Thickness)	DTI	≥0.4	≥0.4	mm
Safety Limit Values– Maximum Values Allowed in the Event of a Failure,				
Case Temperature	$T_S$	150	150	°C
Input Current	$I_{S,INPUT}$	200	200	mA
Output Power	$P_{S,OUTPUT}$	600	600	mW
Insulation Resistance at $T_S, V_{IO} = 500$ V	$R_{IO}$	$10^9$	$10^9$	$\Omega$

**FOD8342, FOD8342T****Table 4. ABSOLUTE MAXIMUM RATINGS** ( $T_A = 25^\circ\text{C}$  unless otherwise specified)

Symbol	Parameter	Value	Units
$T_{STG}$	Storage Temperature	-40 to +125	$^\circ\text{C}$
$T_{OPR}$	Operating Temperature	-40 to +100	$^\circ\text{C}$
$T_J$	Junction Temperature	-40 to +125	$^\circ\text{C}$
$T_{SOL}$	Lead Solder Temperature ( <i>Refer to Reflow Temperature Profile</i> )	260 for 10 s	$^\circ\text{C}$
$I_{F(AVG)}$	Average Input Current	25	mA
$V_R$	Reverse Input Voltage	5.0	V
$I_{O(PEAK)}$	Peak Input Voltage (Note 1)	3	A
$V_{DD}$	Supply Voltage	-0.5 to 35	V
$V_{O(PEAK)}$	Peak Output Voltage	0 to $V_{DD}$	V
$t_{R(IN)}, t_{F(IN)}$	Input Signal Rise and Fall Time	250	ns
$PD_I$	Input Power Dissipation (Notes 2, 4)	45	mW
$PD_O$	Output Power Dissipation (Notes 3, 4)	500	mW

Stresses exceeding those listed in the Maximum Ratings table may damage the device. If any of these limits are exceeded, device functionality should not be assumed, damage may occur and reliability may be affected.

1. Maximum pulse width = 10  $\mu\text{s}$ , maximum duty cycle = 0.2%.
2. No derating required across operating temperature range.
3. Derate linearly from 25 $^\circ\text{C}$  at a rate of 5.2 mW/ $^\circ\text{C}$ .
4. Functional operation under these conditions is not implied. Permanent damage may occur if the device is subjected to conditions outside these ratings.

**Table 5. RECOMMENDED OPERATING CONDITIONS**

Symbol	Parameter	Min	Max	Unit
$T_A$	Ambient Operating Temperature	-40	+100	$^\circ\text{C}$
$V_{DD} - V_{SS}$	Supply Voltages	10	30	V
$I_{F(ON)}$	Input Current (ON)	10	16	mA
$V_{F(OFF)}$	Input Voltage (OFF)	-3.0	0.8	V

Functional operation above the stresses listed in the Recommended Operating Ranges is not implied. Extended exposure to stresses beyond the Recommended Operating Ranges limits may affect device reliability.

**Table 6. ISOLATION CHARACTERISTICS** (Apply over all recommended conditions, typical value is measured at  $T_A = 25^\circ\text{C}$ )

Symbol	Parameter	Conditions	Min	Typ	Max	Units
$V_{ISO}$	Input-Output Isolation Voltage	$T_A = 25^\circ\text{C}$ , R.H. < 50%, $t = 1.0$ min, $I_{I-O} \leq 20 \mu\text{A}$ (Notes 5, 6)	5000			$V_{ACRMS}$
$R_{ISO}$	Isolation Resistance	$V_{I-O} = 500$ V (Note 5)		$10^{11}$		$\Omega$
$C_{ISO}$	Isolation Capacitance	$V_{I-O} = 0$ V, freq = 1.0 MHz (Note 5)		1		pF

5. Device is considered a two terminal device: Pins 1, 2 and 3 are shorted together and Pins 4, 5, and 6 are shorted together.
6. 5,000  $V_{ACRMS}$  for 1 minute duration is equivalent to 6,000  $V_{ACRMS}$  for 1 second duration.

**FOD8342, FOD8342T****Table 7. ELECTRICAL CHARACTERISTICS** (Apply over all recommended conditions,  $T_A = -40^{\circ}\text{C}$  to  $+100^{\circ}\text{C}$ ,  $4.5\text{ V} \leq V_{DD} \leq 30\text{ V}$ , FOD8480:  $I_{F(ON)} = 6\text{ mA}$  to  $10\text{ mA}$ , FOD8482:  $I_{F(ON)} = 4\text{ mA}$  to  $7\text{ mA}$ ,  $V_{F(OFF)} = 0$  to  $0.8\text{ V}$ , unless otherwise specified. Typical value is measured at  $T_A = 25^{\circ}\text{C}$  and  $V_{DD} = 5\text{ V}$ .)

Symbol	Parameter	Conditions	Min	Typ	Max	Units
$V_F$	Input Forward Voltage	$I_F = 10\text{ mA}$	1.1	1.5	1.8	V
$\Delta V_F/\Delta T_A$	Temperature Coefficient of Forward Voltage			-1.8		mV/ $^{\circ}\text{C}$
$BV_R$	Input Reverse Breakdown Voltage	$I_R = 10\text{ }\mu\text{A}$	5.0			V
$C_{IN}$	Input Capacitance	$V_F = 0\text{ V}$ , $f = 1\text{ MHz}$		20		pF
$I_{OH}$	High Level Output Current (Note 1)	$V_{OH} = V_{DD} - 3\text{ V}$	1.0			A
		$V_{OH} = V_{DD} - 6\text{ V}$	2.5			
$I_{OL}$	Low Level Output Current (Note 1)	$V_{OL} = V_{SS} + 3\text{ V}$	1.0			A
		$V_{OL} = V_{SS} + 6\text{ V}$	2.5			
$V_{OH}$	High Level Output Voltage (Notes 7, 8)	$I_F = 10\text{ mA}$ , $I_O = -100\text{ mA}$	$V_{DD} - 0.5$	$V_{DD} - 0.1$		V
$V_{OL}$	Low Level Output Voltage (Notes 7, 8)	$I_F = 0\text{ mA}$ , $I_O = 100\text{ mA}$		$V_{SS} + 0.1$	$V_{SS} + 0.5$	
$I_{DDH}$	High Output Supply Current	$V_O = \text{Open}$ , $I_F = 10$ to $16\text{ mA}$		2.9	4.0	mA
$I_{DDL}$	Low Output Supply Current	$V_O = \text{Open}$ , $V_F = -3.0$ to $0.8\text{ V}$		2.8	4.0	mA
$I_{FLH}$	Threshold Input Current Low to High	$I_O = 0\text{ mA}$ , $V_O > 5\text{ V}$		2.0	7.5	mA
$V_{FHL}$	Threshold Input Voltage High to Low	$I_O = 0\text{ mA}$ , $V_O < 5\text{ V}$	0.8			V
$V_{UVLO+}$	Under Voltage Lockout Threshold	$I_F = 10\text{ mA}$ , $V_O > 5\text{ V}$	7.0	8.3	9.5	V
$V_{UVLO-}$		$I_F = 10\text{ mA}$ , $V_O < 5\text{ V}$	6.5	7.7	9.0	
$UVLO_{HYS}$	Under Voltage Lockout Threshold Hysteresis			0.6		V

Product parametric performance is indicated in the Electrical Characteristics for the listed test conditions, unless otherwise noted. Product performance may not be indicated by the Electrical Characteristics if operated under different conditions.

7. In this test,  $V_{OH}$  is measured with a dc load current of 100 mA. When driving capacitive load  $V_{OH}$  will approach  $V_{DD}$  as  $I_{OH}$  approaches 0 A.

8. Maximum pulse width = 1 ms, maximum duty cycle = 20%.

**FOD8342, FOD8342T****Table 8. SWITCHING CHARACTERISTICS** (Apply over all recommended conditions, typical value is measured at  $T_A = 25^\circ\text{C}$ ,  $V_{SS} = \text{Ground}$  and  $V_{DD} = 30\text{ V}$ , unless otherwise specified.)

Symbol	Parameter	Conditions	Min	Typ	Max	Units
$t_{PHL}$	Propagation Delay Time to Logic Low Output (Note 9)	$I_F = 10\text{ mA}$ , $R_g = 10\ \Omega$ , $C_g = 10\text{ nF}$ , $f = 250\text{ kHz}$ , Duty Cycle = 50%	50	145	210	ns
$t_{PLH}$	Propagation Delay Time to Logic High Output (Note 10)		50	120	210	ns
PWD	Pulse Width Distortion, $ t_{PHL} - t_{PLH} $ (Note 11)			35	65	ns
PDD (Skew)	Propagation Delay Difference Between Any Two Parts (Note 12)		-90		90	
$t_R$	Output Rise Time (10% to 90%)			38		ns
$t_F$	Output Fall Time (90% to 10%)			24		ns
$t_{UVLO\ ON}$	ULVO Turn On Delay		$I_F = 10\text{ mA}$ , $V_O > 5\text{ V}$		2.0	
$t_{UVLO\ OFF}$	ULVO Turn Off Delay	$I_F = 10\text{ mA}$ , $V_O < 5\text{ V}$		0.3		$\mu\text{s}$
$ CM_H $	Common Mode Transient Immunity at Output High	$V_{DD} = 30\text{ V}$ , $I_F = 10\text{ mA}$ to $16\text{ mA}$ , $V_{CM} = 2000\text{ V}$ , $T_A = 25^\circ\text{C}$ (Note 13)	20	50		$\text{kV}/\mu\text{s}$
$ CM_L $	Common Mode Transient Immunity at Output Low	$V_{DD} = 30\text{ V}$ , $V_F = 0\text{ V}$ , $V_{CM} = 2000\text{ V}$ , $T_A = 25^\circ\text{C}$ (Note 14)	20	50		$\text{kV}/\mu\text{s}$

9. Propagation delay  $t_{PHL}$  is measured from the 50% level on the falling edge of the input pulse to the 50% level of the falling edge of the  $V_O$  signal.
10. Propagation delay  $t_{PLH}$  is measured from the 50% level on the rising edge of the input pulse to the 50% level of the rising edge of the  $V_O$  signal.
11. PWD is defined as  $|t_{PHL} - t_{PLH}|$  for any given device.
12. The difference between  $t_{PHL}$  and  $t_{PLH}$  between any two FOD8342 parts under the same operating conditions, with equal loads.
13. Common mode transient immunity at output high is the maximum tolerable negative  $dV_{cm}/dt$  on the trailing edge of the common mode impulse signal,  $V_{CM}$ , to ensure that the output remains high (i.e.,  $V_O > 15.0\text{ V}$ ).
14. Common mode transient immunity at output low is the maximum tolerable positive  $dV_{cm}/dt$  on the leading edge of the common pulse signal,  $V_{CM}$ , to ensure that the output remains low (i.e.,  $V_O < 1.0\text{ V}$ ).

# FOD8342, FOD8342T

## TYPICAL CHARACTERISTICS

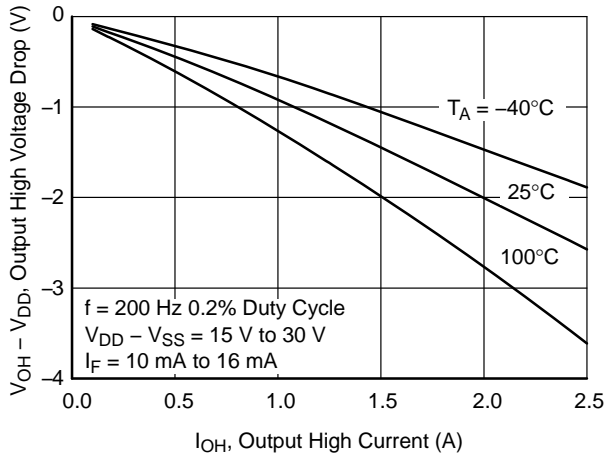

**Figure 2. Output High Voltage Drop vs. Output High Current**

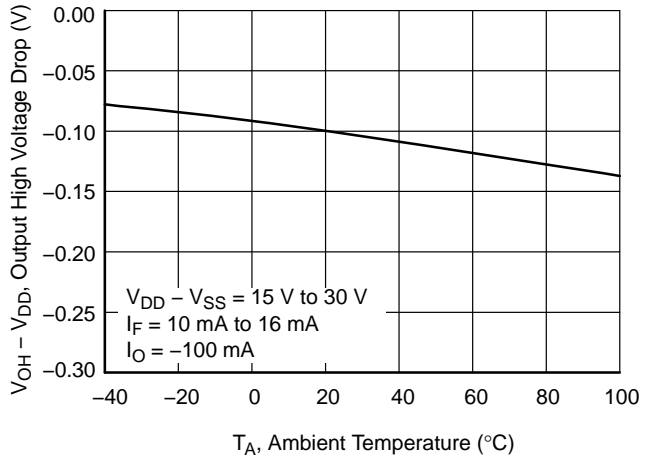

**Figure 3. Output High Voltage Drop vs. Ambient Temperature**

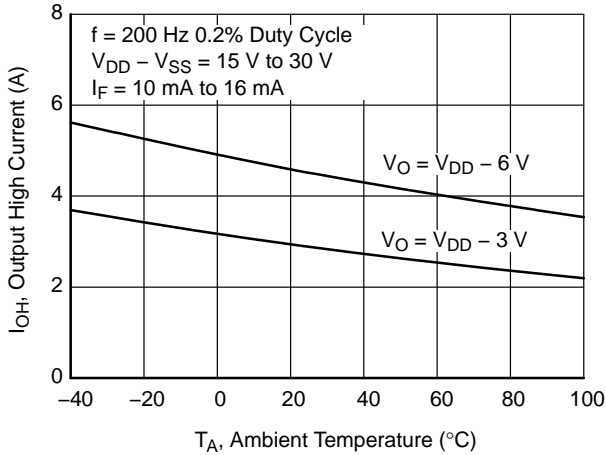

**Figure 4. Output High Current vs. Ambient Temperature**

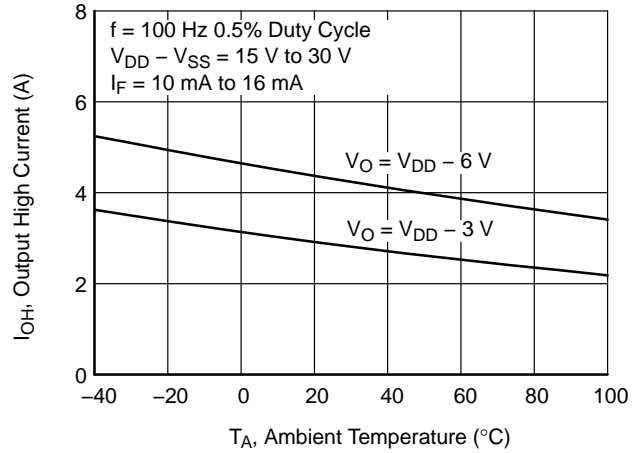

**Figure 5. Output High Current vs. Ambient Temperature**

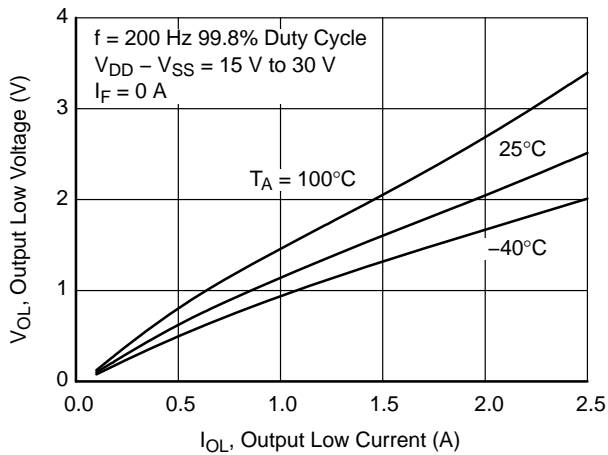

**Figure 6. Output Low Voltage vs. Output Low Current**

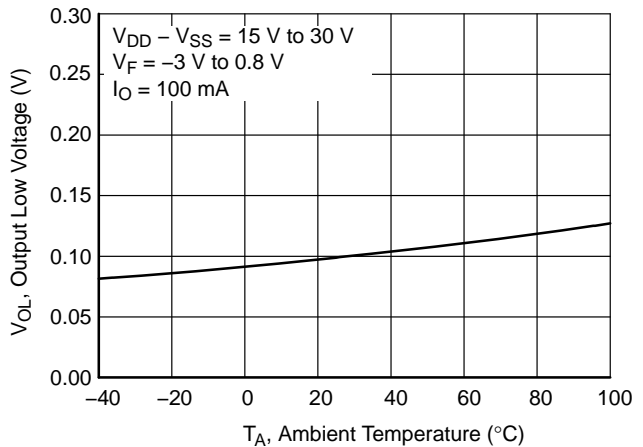

**Figure 7. Output Low Voltage vs. Ambient Temperature**

# FOD8342, FOD8342T

## TYPICAL CHARACTERISTICS (CONTINUED)

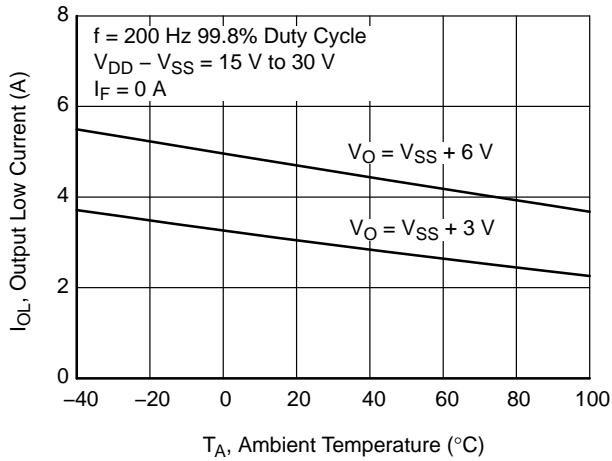

**Figure 8. Output Low Current vs. Ambient Temperature**

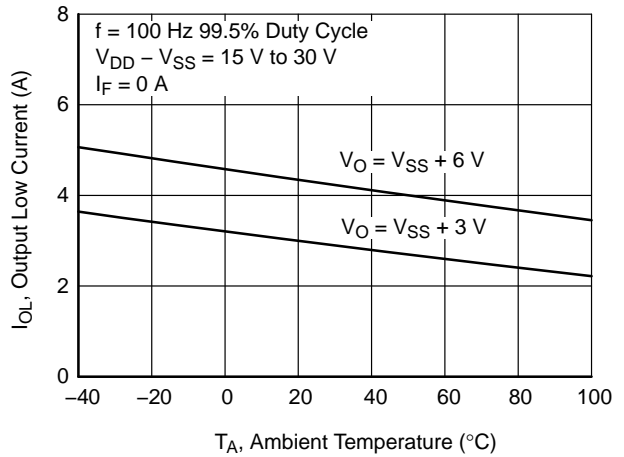

**Figure 9. Output Low Current vs. Ambient Temperature**

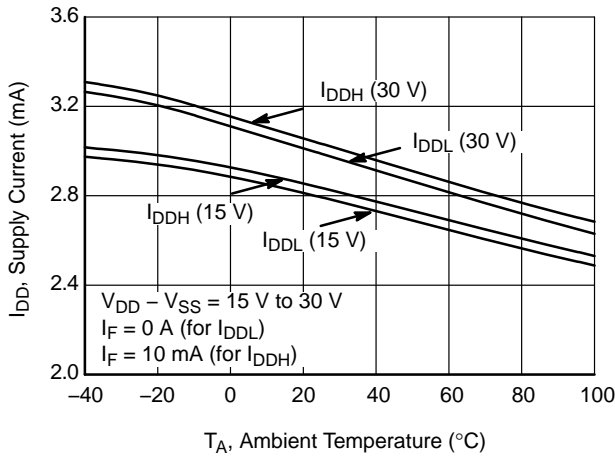

**Figure 10. Supply Current vs. Ambient Temperature**

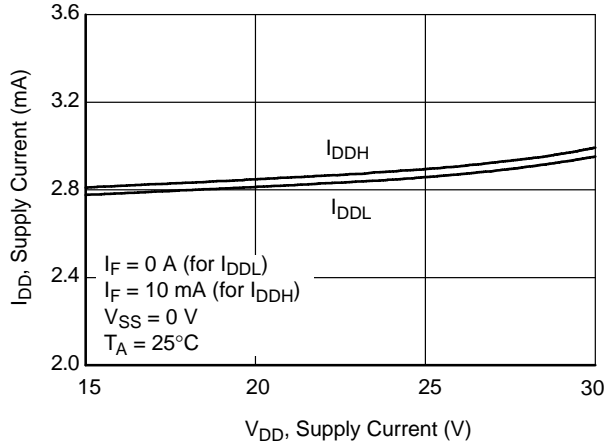

**Figure 11. Supply Current vs. Supply Voltage**

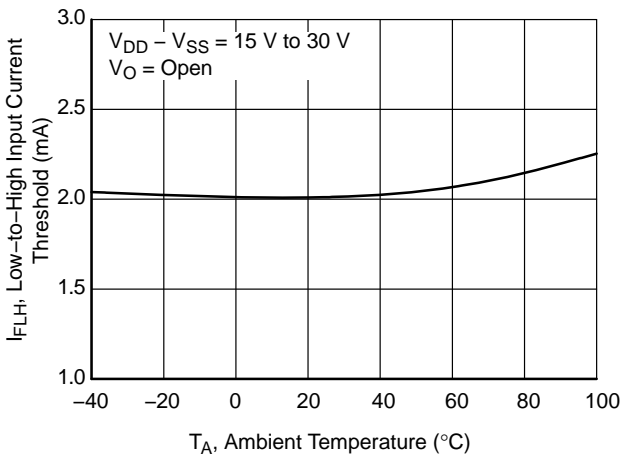

**Figure 12. Low-to-High Input Current Threshold vs. Ambient Temperature**

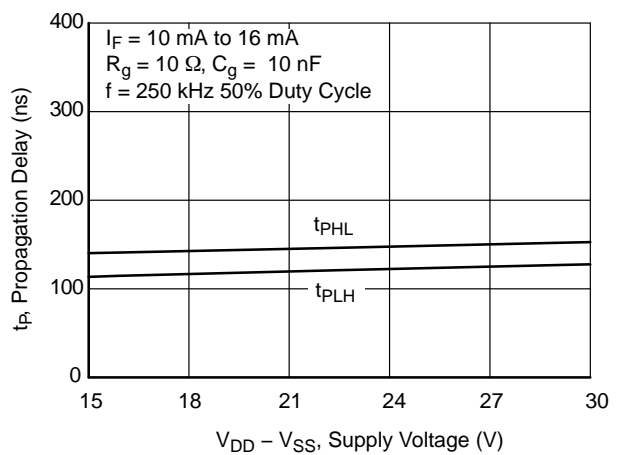

**Figure 13. Propagation Delay vs. Supply Voltage**

# FOD8342, FOD8342T

## TYPICAL CHARACTERISTICS (CONTINUED)

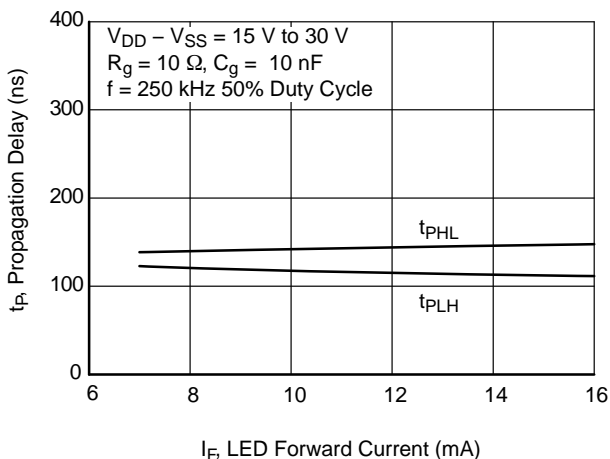

**Figure 14. Propagation Delay vs. LED Forward Current**

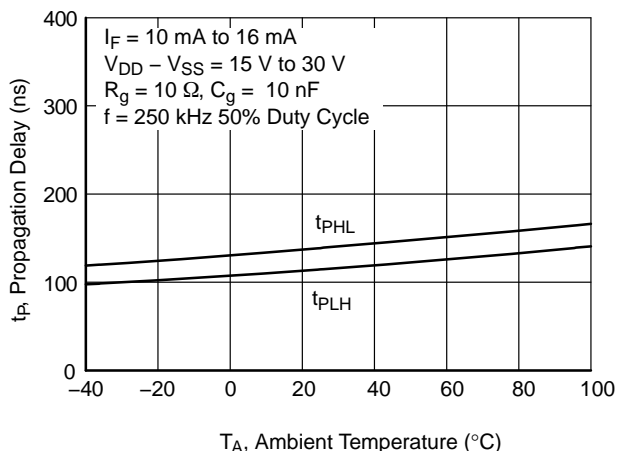

**Figure 15. Propagation Delay vs. Ambient Temperature**

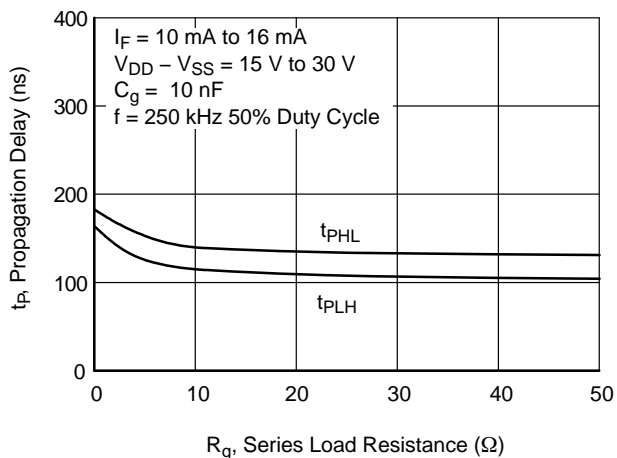

**Figure 16. Propagation Delay vs. Series Load Resistance**

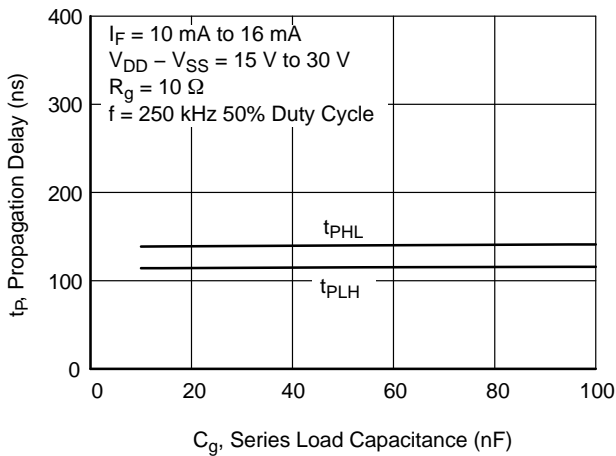

**Figure 17. Propagation Delay vs. Series Load Capacitance**

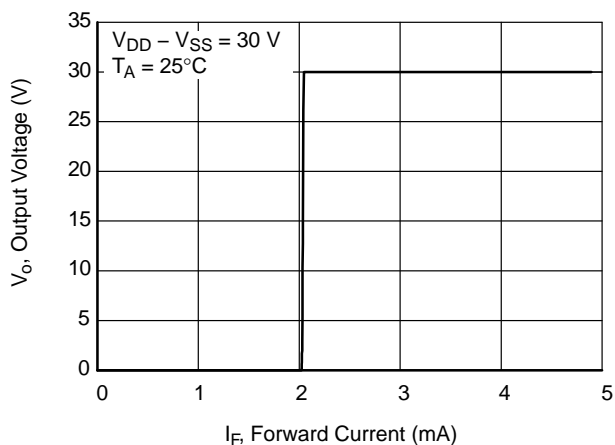

**Figure 18. Transfer Characteristics**

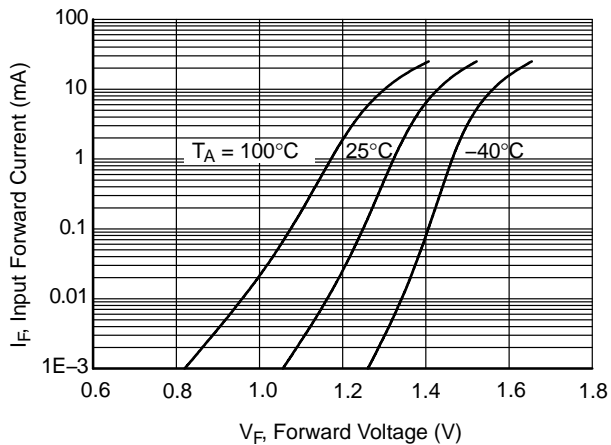

**Figure 19. Input Forward Current vs. Forward Voltage**

# FOD8342, FOD8342T

## TYPICAL CHARACTERISTICS (CONTINUED)

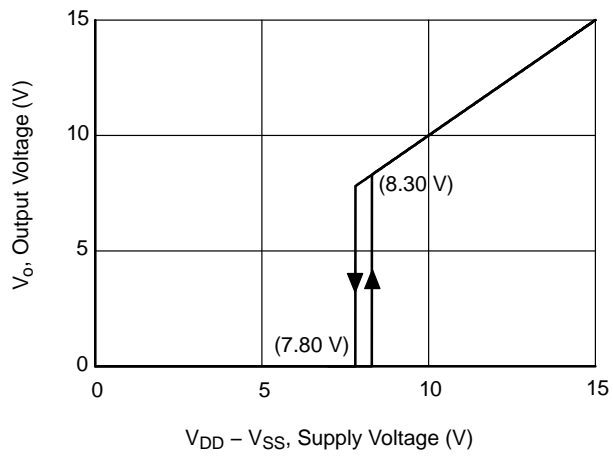

**Figure 20. Under Voltage Lockout**

**FOD8342, FOD8342T**

**TEST CIRCUIT**

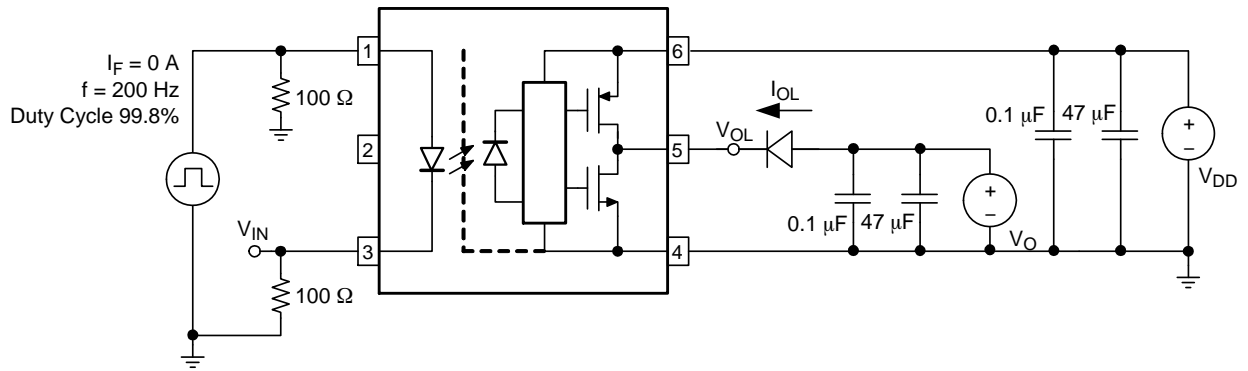

**Figure 21.  $I_{OL}$  Test Circuit**

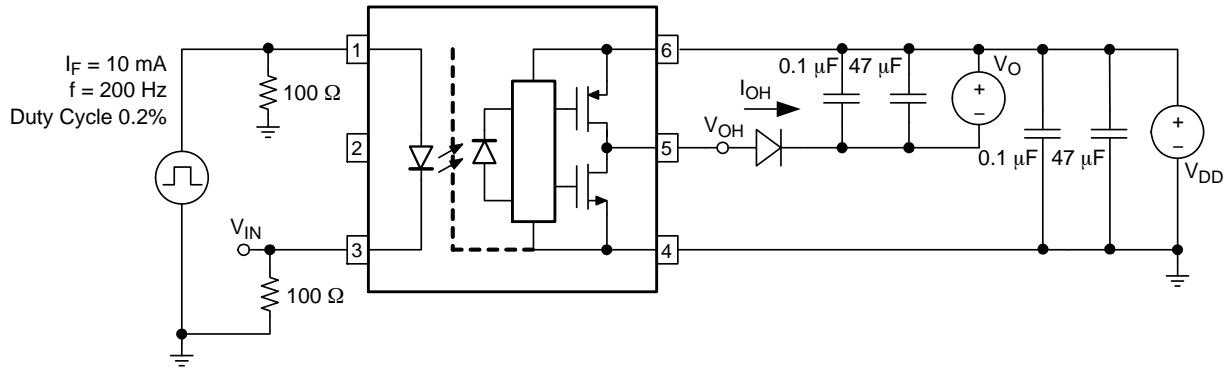

**Figure 22.  $I_{OH}$  Test Circuit**

**FOD8342, FOD8342T**

**TEST CIRCUIT (CONTINUED)**

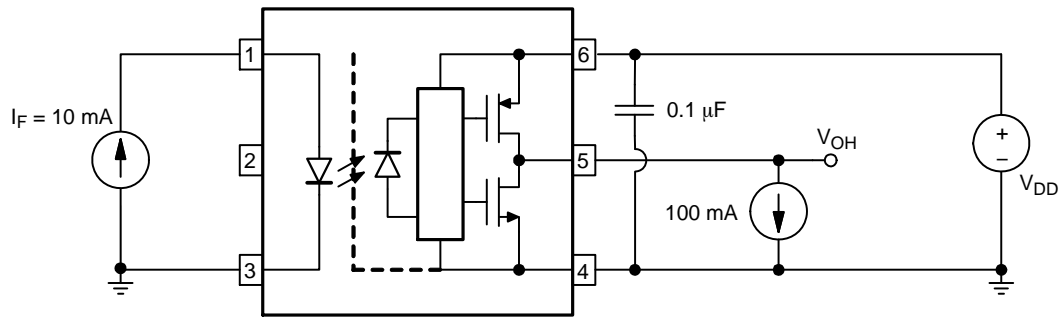

**Figure 23.  $V_{OH}$  Test Circuit**

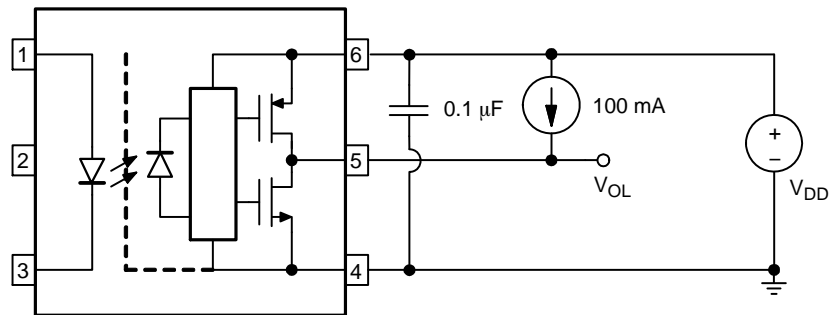

**Figure 24.  $V_{OL}$  Test Circuit**

**FOD8342, FOD8342T**

**TEST CIRCUIT (CONTINUED)**

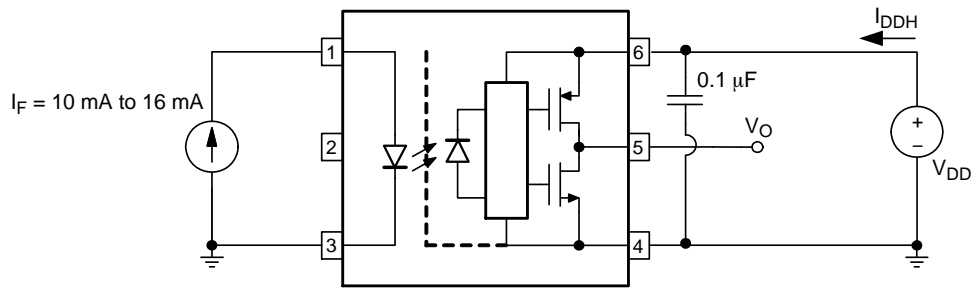

**Figure 25.  $I_{DDH}$  Test Circuit**

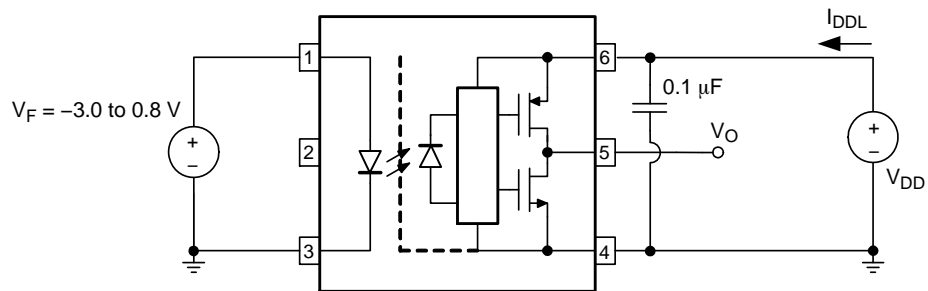

**Figure 26.  $I_{DDL}$  Test Circuit**

### FOD8342, FOD8342T

#### TEST CIRCUIT (CONTINUED)

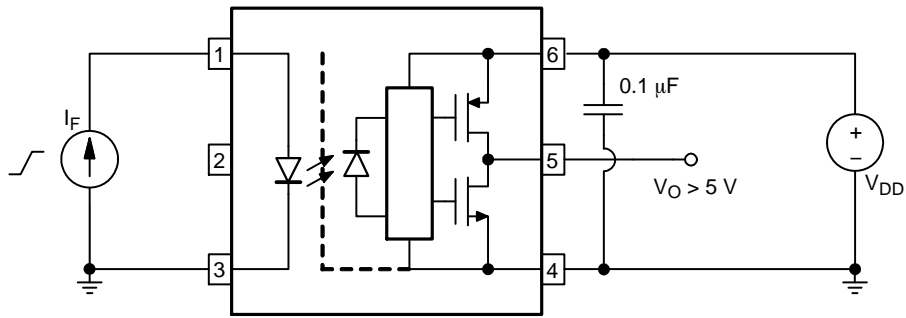

Figure 27.  $I_{FLH}$  Test Circuit

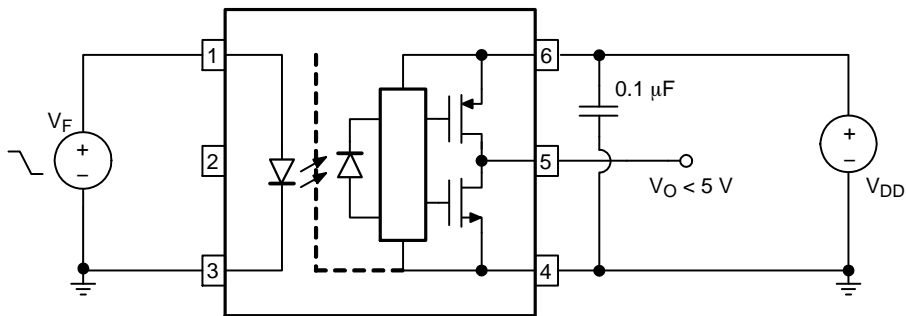

Figure 28.  $V_{FHL}$  Test Circuit

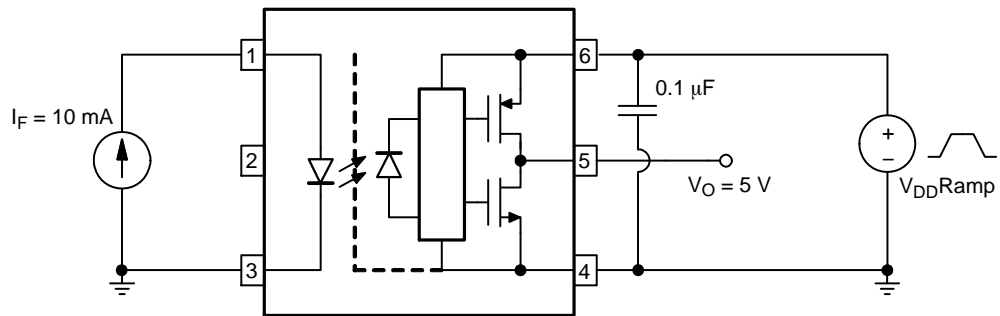

Figure 29. UVLO Test Circuit

### FOD8342, FOD8342T

#### TEST CIRCUIT (CONTINUED)

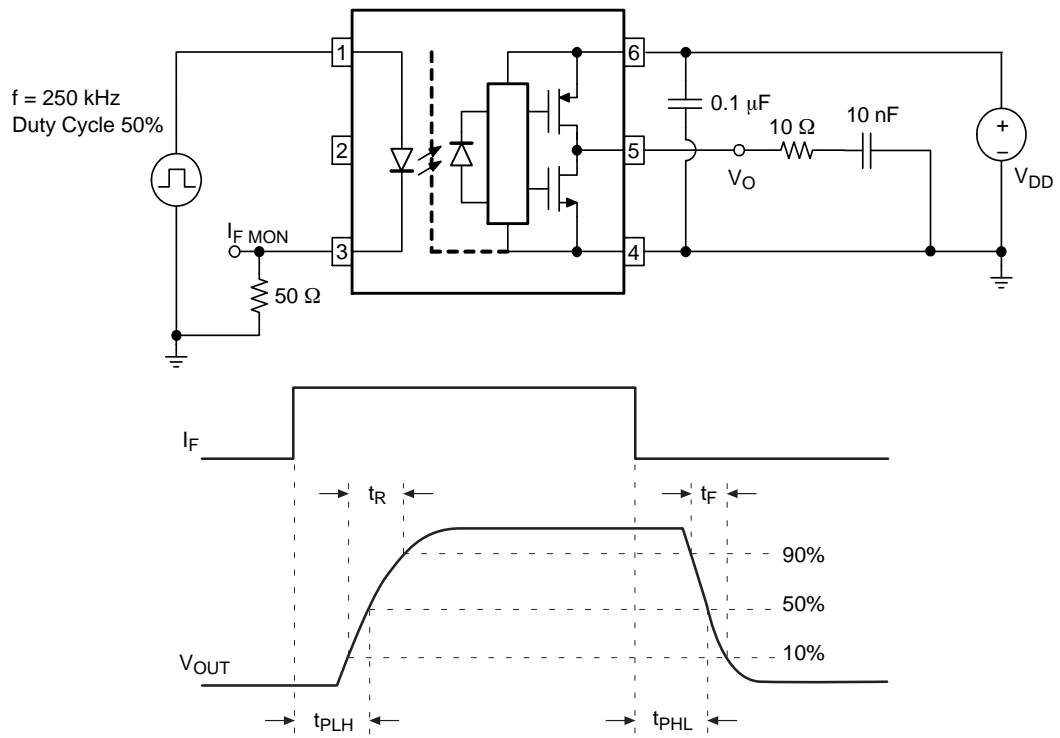
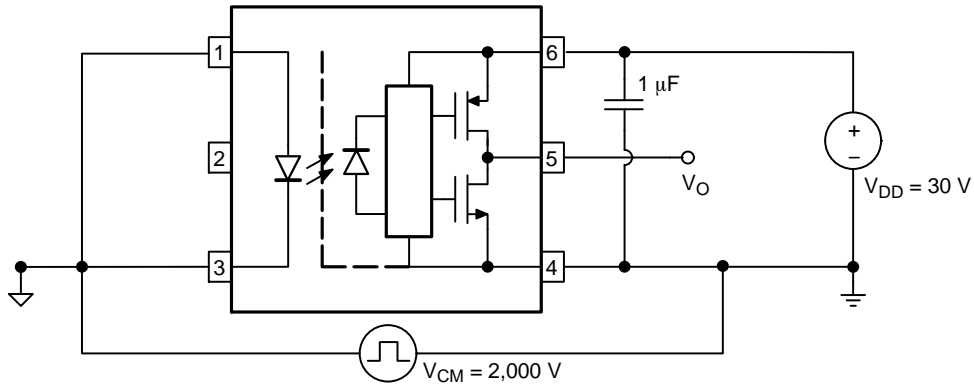

Figure 30. t<sub>PHL</sub>, t<sub>PLH</sub>, t<sub>R</sub> and t<sub>F</sub> Test Circuit and Waveforms

### FOD8342, FOD8342T

#### TEST CIRCUIT (CONTINUED)



**Common-Mode Low (CML) Test Circuit**

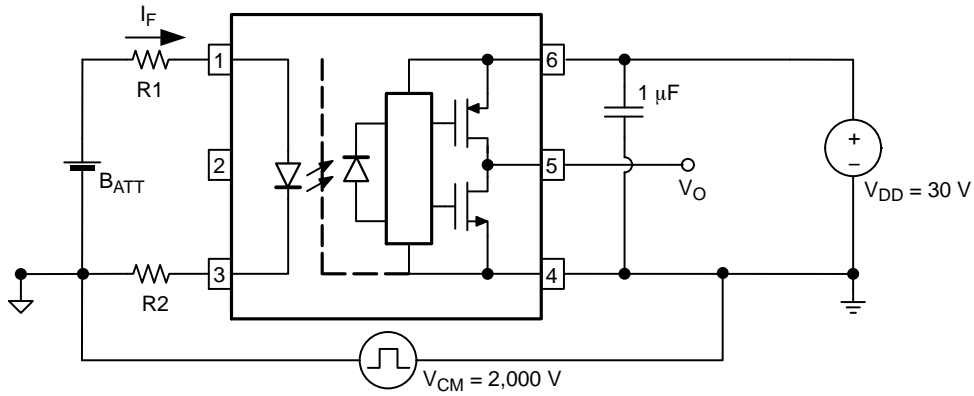

**Common-Mode High (CMH) Test Circuit**

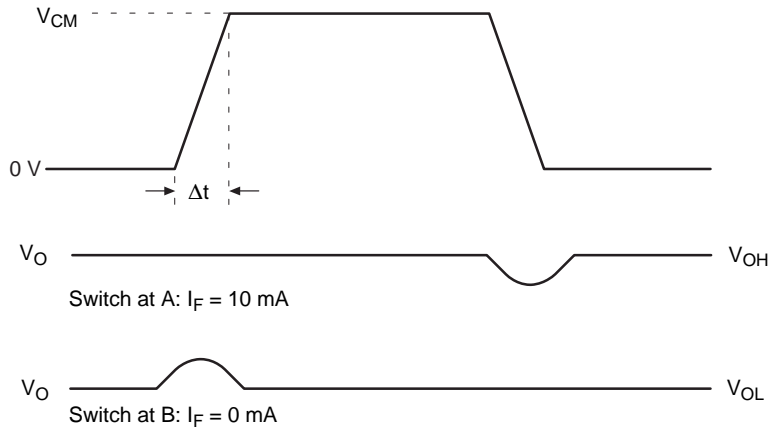

**Figure 31. CMR Test Circuit and Waveforms**

## FOD8342, FOD8342T

### REFLOW PROFILE

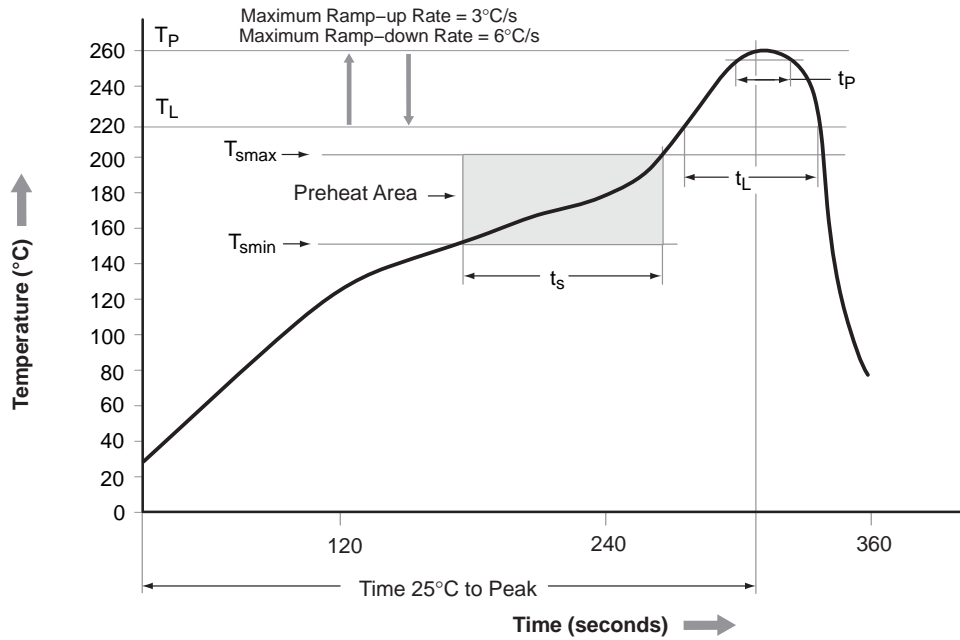

Profile Feature	Pb-Free Assembly Profile
Temperature Minimum ( $T_{smin}$ )	150°C
Temperature Maximum ( $T_{smax}$ )	200°C
Time ( $t_s$ ) from ( $T_{smin}$ to $T_{smax}$ )	60 s to 120 s
Ramp-up Rate ( $t_L$ to $t_p$ )	3°C/s maximum
Liquidous Temperature ( $T_L$ )	217°C
Time ( $t_L$ ) Maintained Above ( $T_L$ )	60 s to 150 s
Peak Body Package Temperature	260°C +0°C / -5°C
Time ( $t_p$ ) within 5°C of 260°C	30 s
Ramp-Down Rate ( $T_P$ to $T_L$ )	6°C/s maximum
Time 25°C to Peak Temperature	8 minutes maximum

Figure 32. Reflow Profile

**FOD8342, FOD8342T****ORDERING INFORMATION**

Part Number	Package	Packing Method
FOD8342	Stretched Body SOP 6-Pin	Tube (100 units per tube)
FOD8342R2	Stretched Body SOP 6-Pin	Tape and Reel (1,000 units per reel)
FOD8342V	Stretched Body SOP 6-Pin, DIN EN/IEC60747-5-5 Option	Tube (100 units per tube)
FOD8342R2V	Stretched Body SOP 6-Pin, DIN EN/ IEC60747-5-5 Option	Tape and Reel (1,000 units per reel)
FOD8342T	Stretched Body SOP 6-Pin, Wide Lead	Tube (100 units per tube)
FOD8342TR2	Stretched Body SOP 6-Pin, Wide Lead	Tape and Reel (1,000 units per reel)
FOD8342TR2V	Stretched Body SOP 6-Pin, Wide Lead, DIN EN/ IEC60747-5-5 Option	Tape and Reel (1,000 units per reel)

**DISCONTINUED** (Note 15)

FOD8342TV	Stretched Body SOP 6-Pin, Wide Lead, DIN EN/IEC60747-5-5 Option	Tube (100 units per tube)
-----------	--	---------------------------

\*All packages are lead free per JEDEC: J-STD-020B standard.

15. **DISCONTINUED:** This device is not recommended for new design. Please contact your **onsemi** representative for information. The most current information on this device may be available on [www.onsemi.com](http://www.onsemi.com).



**SOIC6 W**  
**CASE 751EM**  
**ISSUE O**

DATE 30 SEP 2016

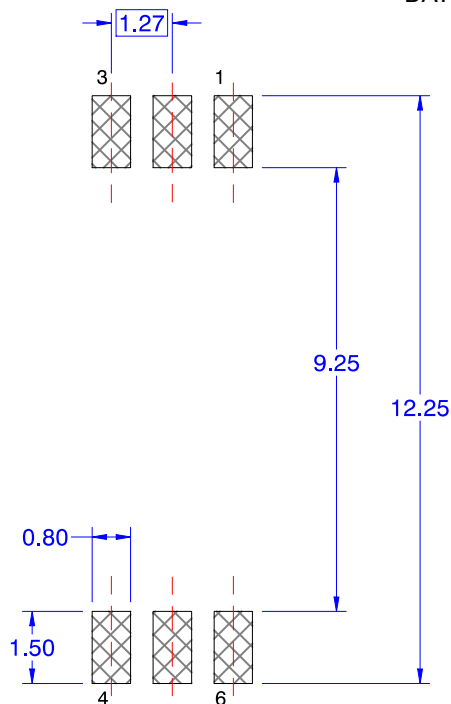
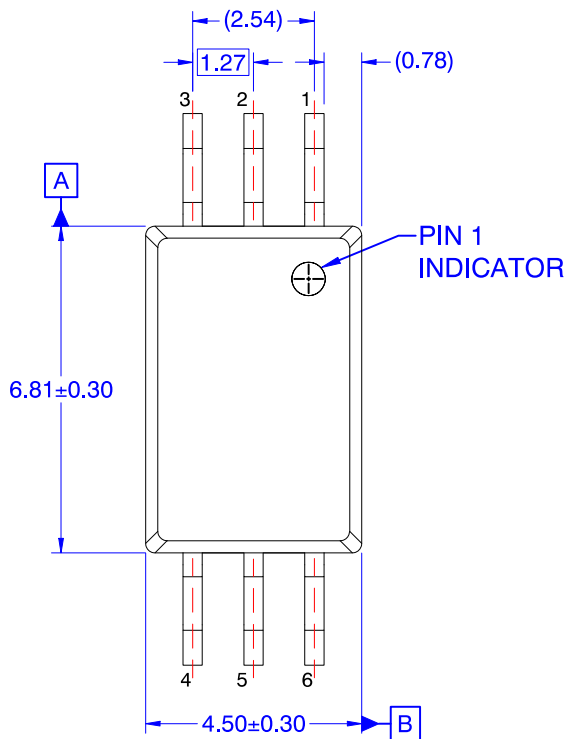

**RECOMMENDED LAND PATTERN**

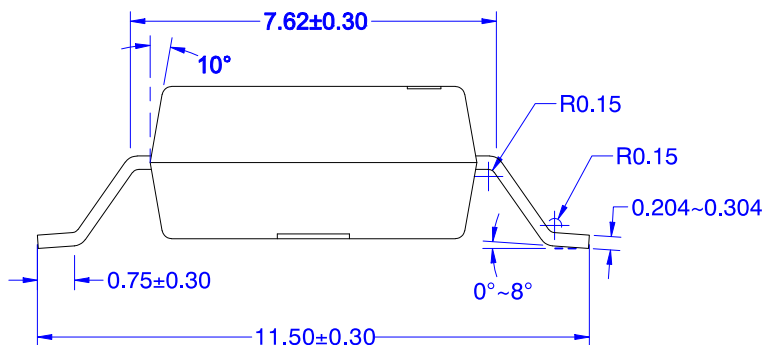
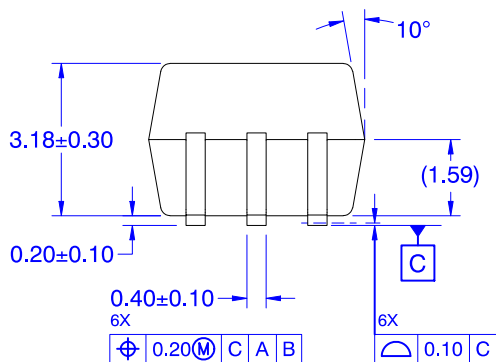

- NOTES: UNLESS OTHERWISE SPECIFIED**
- A) NO STANDARD APPLIES TO THIS PACKAGE
  - B) ALL DIMENSIONS ARE IN MILLIMETERS.
  - C) DIMENSIONS DO NOT INCLUDE BURRS OR MOLD FLASH, AND TIE BAR EXTRUSION.
  - D) DIMENSIONING AND TOLERANCING PER ASME Y14.5M-2009.

<b>DOCUMENT NUMBER:</b>	<b>98AON13749G</b>	Electronic versions are uncontrolled except when accessed directly from the Document Repository. Printed versions are uncontrolled except when stamped "CONTROLLED COPY" in red.
<b>DESCRIPTION:</b>	<b>SOIC6 W</b>	<b>PAGE 1 OF 1</b>

onsemi and ONSEMI are trademarks of Semiconductor Components Industries, LLC dba onsemi or its subsidiaries in the United States and/or other countries. onsemi reserves the right to make changes without further notice to any products herein. onsemi makes no warranty, representation or guarantee regarding the suitability of its products for any particular purpose, nor does onsemi assume any liability arising out of the application or use of any product or circuit, and specifically disclaims any and all liability, including without limitation special, consequential or incidental damages. onsemi does not convey any license under its patent rights nor the rights of others.

**onsemi**, **Onsemi**, and other names, marks, and brands are registered and/or common law trademarks of Semiconductor Components Industries, LLC dba "**onsemi**" or its affiliates and/or subsidiaries in the United States and/or other countries. **onsemi** owns the rights to a number of patents, trademarks, copyrights, trade secrets, and other intellectual property. A listing of **onsemi**'s product/patent coverage may be accessed at [www.onsemi.com/site/pdf/Patent-Marking.pdf](http://www.onsemi.com/site/pdf/Patent-Marking.pdf). **onsemi** reserves the right to make changes at any time to any products or information herein, without notice. The information herein is provided "as-is" and **onsemi** makes no warranty, representation or guarantee regarding the accuracy of the information, product features, availability, functionality, or suitability of its products for any particular purpose, nor does **onsemi** assume any liability arising out of the application or use of any product or circuit, and specifically disclaims any and all liability, including without limitation special, consequential or incidental damages. Buyer is responsible for its products and applications using **onsemi** products, including compliance with all laws, regulations and safety requirements or standards, regardless of any support or applications information provided by **onsemi**. "Typical" parameters which may be provided in **onsemi** data sheets and/or specifications can and do vary in different applications and actual performance may vary over time. All operating parameters, including "Typicals" must be validated for each customer application by customer's technical experts. **onsemi** does not convey any license under any of its intellectual property rights nor the rights of others. **onsemi** products are not designed, intended, or authorized for use as a critical component in life support systems or any FDA Class 3 medical devices or medical devices with a same or similar classification in a foreign jurisdiction or any devices intended for implantation in the human body. Should Buyer purchase or use **onsemi** products for any such unintended or unauthorized application, Buyer shall indemnify and hold **onsemi** and its officers, employees, subsidiaries, affiliates, and distributors harmless against all claims, costs, damages, and expenses, and reasonable attorney fees arising out of, directly or indirectly, any claim of personal injury or death associated with such unintended or unauthorized use, even if such claim alleges that **onsemi** was negligent regarding the design or manufacture of the part. **onsemi** is an Equal Opportunity/Affirmative Action Employer. This literature is subject to all applicable copyright laws and is not for resale in any manner.

#### ADDITIONAL INFORMATION

**TECHNICAL PUBLICATIONS:**

Technical Library: [www.onsemi.com/design/resources/technical-documentation](http://www.onsemi.com/design/resources/technical-documentation)  
onsemi Website: [www.onsemi.com](http://www.onsemi.com)

**ONLINE SUPPORT:** [www.onsemi.com/support](http://www.onsemi.com/support)

For additional information, please contact your local Sales Representative at [www.onsemi.com/support/sales](http://www.onsemi.com/support/sales)

## OUR CERTIFICATE

DiGi provide top-quality products and perfect service for customer worldwide through standardization, technological innovation and continuous improvement. DiGi through third-party certification, we stricly control the quality of products and services. Welcome your RFQ to

Email: [Info@DiGi-Electronics.com](mailto:Info@DiGi-Electronics.com)



Tel: +00 852-30501935

RFQ Email: [Info@DiGi-Electronics.com](mailto:Info@DiGi-Electronics.com)

DiGi is a global authorized distributor of electronic components.