

FSA550BUCX Datasheet

www.digi-electronics.com

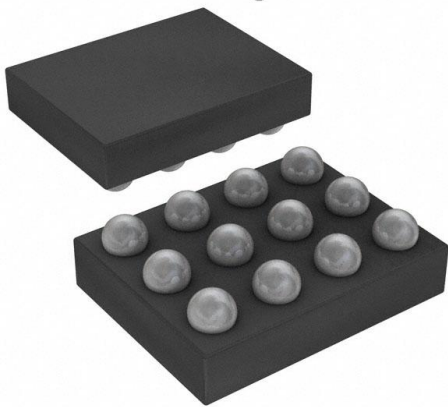

<https://www.DiGi-Electronics.com>

DiGi Electronics Part Number	FSA550BUCX-DG
Manufacturer	onsemi
Manufacturer Product Number	FSA550BUCX
Description	IC ISOLATION SWITCH 4PST 12WLCSP
Detailed Description	Audio Switch IC 1 Channel 12-WLCSP (1.16x1.56)



Tel: +00 852-30501935

RFQ Email: Info@DiGi-Electronics.com

DiGi is a global authorized distributor of electronic components.

Purchase and inquiry

Manufacturer Product Number:

FSA550BUCX

Series:

-

Applications:

Audio

Switch Circuit:

4PST

On-State Resistance (Max):

800mOhm (Typ)

Voltage - Supply, Dual (V±):

-

Features:

-

Mounting Type:

Surface Mount

Supplier Device Package:

12-WLCSP (1.16x1.56)

Manufacturer:

onsemi

Product Status:

Obsolete

Multiplexer/Demultiplexer Circuit:

-

Number of Channels:

1

Voltage - Supply, Single (V+):

1.6V ~ 3V

-3db Bandwidth:

50MHz

Operating Temperature:

-40°C ~ 85°C (TA)

Package / Case:

12-UFBGA, WLCSP

Base Product Number:

FSA550

Environmental & Export classification

RoHS Status:

ROHS3 Compliant

REACH Status:

REACH Unaffected

HTSUS:

8542.39.0001

Moisture Sensitivity Level (MSL):

1 (Unlimited)

ECCN:

EAR99



Is Now Part of



ON Semiconductor®

To learn more about ON Semiconductor, please visit our website at
www.onsemi.com

Please note: As part of the Fairchild Semiconductor integration, some of the Fairchild orderable part numbers will need to change in order to meet ON Semiconductor's system requirements. Since the ON Semiconductor product management systems do not have the ability to manage part nomenclature that utilizes an underscore (_), the underscore (_) in the Fairchild part numbers will be changed to a dash (-). This document may contain device numbers with an underscore (_). Please check the ON Semiconductor website to verify the updated device numbers. The most current and up-to-date ordering information can be found at www.onsemi.com. Please email any questions regarding the system integration to Fairchild_questions@onsemi.com.

ON Semiconductor and the ON Semiconductor logo are trademarks of Semiconductor Components Industries, LLC dba ON Semiconductor or its subsidiaries in the United States and/or other countries. ON Semiconductor owns the rights to a number of patents, trademarks, copyrights, trade secrets, and other intellectual property. A listing of ON Semiconductor's product/patent coverage may be accessed at www.onsemi.com/site/pdf/Patent-Marking.pdf. ON Semiconductor reserves the right to make changes without further notice to any products herein. ON Semiconductor makes no warranty, representation or guarantee regarding the suitability of its products for any particular purpose, nor does ON Semiconductor assume any liability arising out of the application or use of any product or circuit, and specifically disclaims any and all liability, including without limitation special, consequential or incidental damages. Buyer is responsible for its products and applications using ON Semiconductor products, including compliance with all laws, regulations and safety requirements or standards, regardless of any support or applications information provided by ON Semiconductor. "Typical" parameters which may be provided in ON Semiconductor data sheets and/or specifications can and do vary in different applications and actual performance may vary over time. All operating parameters, including "Typicals" must be validated for each customer application by customer's technical experts. ON Semiconductor does not convey any license under its patent rights nor the rights of others. ON Semiconductor products are not designed, intended, or authorized for use as a critical component in life support systems or any FDA Class 3 medical devices or medical devices with a same or similar classification in a foreign jurisdiction or any devices intended for implantation in the human body. Should Buyer purchase or use ON Semiconductor products for any such unintended or unauthorized application, Buyer shall indemnify and hold ON Semiconductor and its officers, employees, subsidiaries, affiliates, and distributors harmless against all claims, costs, damages, and expenses, and reasonable attorney fees arising out of, directly or indirectly, any claim of personal injury or death associated with such unintended or unauthorized use, even if such claim alleges that ON Semiconductor was negligent regarding the design or manufacture of the part. ON Semiconductor is an Equal Opportunity/Affirmative Action Employer. This literature is subject to all applicable copyright laws and is not for resale in any manner.



FSA550

4PST Depletion Mode Isolation Switch

Features

- 4PST (NC)
- Depletion Mode MOSFETs
- Audio Frequency Range
- $V_{CC(OFF)}$: 1.6 V to 3.0 V
- R_{ON} : 0.8 Ω Typical
- R_{ON} Flat: 0.01 Ω Typical
- THD+N: 0.002% Typical
- Eco Status: Fairchild Green, RoHS Compliant, Halogen Free

Applications

- MP3 Portable Media Players
- Cellular Phones, Smart Phones

Description

The FSA550 is a high-performance four-pole single-throw (4PST) normally closed Depletion-Mode isolation switch. The Depletion Mode technology allows the device to conduct signals when there is no V_{CC} available and to isolate the signals when V_{CC} is present.

The FSA550 operates on a wide V_{CC} range for design flexibility. Additionally, select pins allow the internal oscillator frequency to be adjusted between 500 kHz and 750 kHz in 75 kHz steps when V_{CC} is present. This feature is used to shift the electromagnetic interference (EMI) signature to meet customer specifications.

Related Resources

- FSA550 Evaluation Board

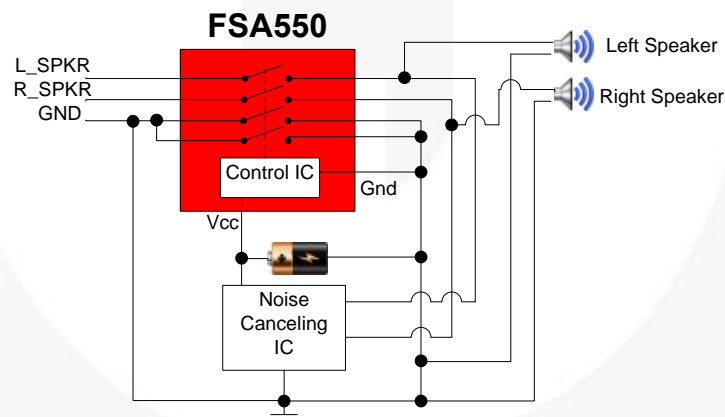

Typical Application

Ordering Information

Part Number	Top Mark	Operating Temperature Range	Package	Packing Method
FSA550UCX	M4	-40 to +85°C	12-Ball WLCSP, 3 x 4 Array, 0.4 mm Pitch, 250 μ m Ball	3000 Units on Tape and Reel
FSA550BUCX	M4	-40 to +85°C	12-Ball WLCSP(with Backside Laminate), 3 x 4 Array, 0.4 mm Pitch, 250 μ m Ball	3000 Units on Tape and Reel

Pin Configuration

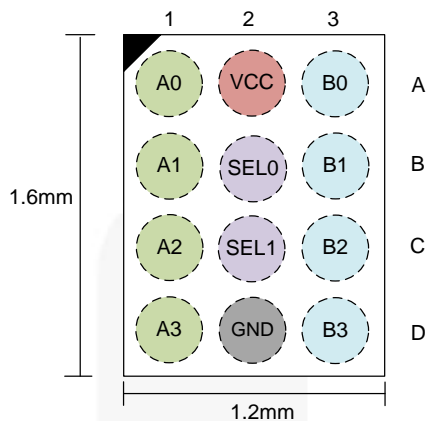

Figure 1. Pin Assignment (Top Through View)

Pin Descriptions

Pin #	Name	Type	Description
A1	A0	I/O	A - Port
B1	A1	I/O	A - Port
C1	A2	I/O	A - Port
D1	A3	I/O	A - Port
A2	V _{CC}	Supply / Control	Isolation Circuit Supply Voltage (see Table 1)
B2	SEL0	Input	Oscillator Frequency Control (see Table 2). Used to shift the electromagnetic interference (EMI) signature to meet the customer specifications.
C2	SEL1	Input	
D2	GND	Ground	System Ground
A3	B0	I/O	B - Port
B3	B1	I/O	B - Port
C3	B2	I/O	B - Port
D3	B3	I/O	B - Port

Table 1. Truth Table

V _{CC}	Function
0 V – 0.2 V	B0-B3 = A0-A3
1.6 V - 3.0 V	Disconnect; B0-B3 ≠ A0-A3

Table 2. Oscillator Frequency Step Logic

SEL1	SEL0	Frequency (Typ.)
LOW	LOW	500 kHz
LOW	HIGH	575 kHz
HIGH	LOW	650 kHz
HIGH	HIGH	725 kHz

Absolute Maximum Ratings

Stresses exceeding the absolute maximum ratings may damage the device. The device may not function or be operable above the recommended operating conditions and stressing the parts to these levels is not recommended. In addition, extended exposure to stresses above the recommended operating conditions may affect device reliability. The absolute maximum ratings are stress ratings only.

Symbol	Parameter		Min.	Max.	Unit
V_{CC}	Supply/Control Voltage		0	4.6	V
V_{IN}	Input Voltage (Select Pins)		0	V_{CC}	V
$V_{SW(ON)}$	DC Switch I/O Voltage (Switch Conducting)	$V_{CC}=0\text{ V}$	-4	+4	V
$V_{SW(OFF)}^{(1)}$	DC Switch I/O Voltage (Switch Isolated)	$V_{CC}=\text{Powered}$	-0.5	3.0	V
I_{IK}	DC Input Diode Current		-50		mA
I_{SW}	Switch I/O Current	$V_{CC}=0\text{ V}$ (Switch Conducting)		350	mA
I_{SWPEAK}	Peak Switch Current	Pulsed at 1 ms Duration, <10% Duty Cycle		500	mA
ESD	Human Body Model, ANSI/ESDA/JEDEC JS-001-2012		All Pins		kV
	Charged Device Model, JEDEC: JESD22-C101				
	IEC 61000-4-2 System	Contact	8.0		
		Air Gap	15.0		
T_A	Absolute Maximum Operating Temperature		-40	+85	°C
T_{STG}	Storage Temperature		-65	+150	°C

Note:

- When a switch is isolated (OFF), V_{SW} value must be $< V_{CC}$.

Recommended Operating Conditions

The Recommended Operating Conditions table defines the conditions for actual device operation. Recommended operating conditions are specified to ensure optimal performance to the datasheet specifications. Fairchild does not recommend exceeding them or designing to Absolute Maximum Ratings.

Symbol	Parameter		Min.	Max.	Unit
$V_{CC(ON)}$	Supply Voltage with Switch Conducting		0	0.2	V
$V_{CC(OFF)}$	Supply Voltage with Switch Isolated		1.6	3.0	V
$V_{SW(ON)}$	DC Switch I/O Voltage (Switch Conducting)	$V_{CC} = 0\text{ V}$	-2	2	V
$V_{SW(OFF)}$	DC Switch I/O Voltage (Switch Isolated)	$V_{CC} = 1.6\text{ V to }3.0\text{ V}$	0	1.4	V

DC Electrical Characteristics

Typical values at $T_A = 25^\circ\text{C}$ unless otherwise specified.

Symbol	Parameter	Condition	V_{CC} (V)	$T_A = -40^\circ\text{C}$ to $+85^\circ\text{C}$			Unit
				Min.	Typ.	Max.	
I_{ON}	Switch-to-GND Leakage Current (Switch Conducting)	$A_n = -1.4\text{ V}$ to 1.4 V , $B_n = \text{Float}$	0	0	0.3	1.0	μA
I_{OFF}	Switch-to-GND Leakage Current (Switch Isolated)	$A_n = 0.4\text{ V}$ to 1.4 V , $B_n = \text{Float}$	3	0	0.5	3.5	μA
R_{ON}	Switch On Resistance ⁽²⁾	$I_{SW} = \pm 24\text{ mA}$, $V_{SW} = -1.4\text{ V}$ to $+1.4\text{ V}$	0		0.8		Ω
$R_{FLAT(ON)}$	On Resistance Flatness ⁽²⁾	$I_{SW} = \pm 24\text{ mA}$, $V_{SW} = -1.4\text{ V}$ to $+1.4\text{ V}$	0		0.01		Ω
I_{CC}	Quiescent Supply Current	$SEL0 = SEL1 = V_{CC}$	3	0	50	70	μA
V_{IH}	Input Voltage High (Select Pins) ⁽³⁾		3	$0.8 \cdot V_{CC}$			V
V_{IL}	Input Voltage Low (Select Pins) ⁽³⁾		3			$0.2 \cdot V_{CC}$	V
I_{IN}	Input Leakage Current (Select Pins)		3	0		± 1	μA

Notes:

- Guaranteed by test and characterization.
- Voltages on select control pins must be $\leq V_{CC}$.

AC Electrical Characteristics

Typical values at $T_A = 25^\circ\text{C}$ unless otherwise specified.

Symbol	Parameter	Condition	V_{CC} (V)	Typ.	Unit
t_{ON}	Turn-On Time V_{CC} to Output ^(4,5)	$R_L = 32\ \Omega$, $C_L = 10\text{ pF}$, $V_{SW} = 1.4\text{ V}$	1.6	120	ns
t_{OFF}	Turn-Off Time V_{CC} to Output ^(4,5)	$R_L = 32\ \Omega$, $C_L = 10\text{ pF}$, $V_{SW} = 1.4\text{ V}$	1.6	160	μs
O_{IRR}	Off Isolation ^(4,5)	$R_L = 32\ \Omega$, $f = 20\text{ kHz}$, $V_{SW} = 0.35\text{ V}_{RMS}$	1.6	-90	dB
X_{TALK}	Crosstalk ^(4,5)	$R_L = 32\ \Omega$, $f = 20\text{ kHz}$, $V_{SW} = 1\text{ V}_{RMS}$	0	-90	dB
BW	-3dB Bandwidth ⁽⁵⁾	$R_L = 50\ \Omega$, $C_L = 0\text{ pF}$	0	<50	MHz
THD+N	Total Harmonic Distortion + Noise ^(4,5)	$R_L = 32\ \Omega$, $f = 20\text{ Hz}$ to 20 kHz , $V_{SW} = 1\text{ V}_{RMS}$	0	0.002	%

Notes:

- $SEL0=SEL1=LOW$.
- Guaranteed by characterization.

Capacitance

$T_A = 25^\circ\text{C}$ unless otherwise noted.

Symbol	Parameter	Condition	Typ.	Unit
C_{ON}	On Capacitance (Switch Conducting)	$V_{CC} = 0\text{ V}$, $f = 1\text{ MHz}$, 400 mV_{PP}	10	pF
C_{OFF}	Off Capacitance (Switch Isolated)	$V_{CC} = 1.6\text{ V}$, $f = 1\text{ MHz}$, 400 mV_{PP}	10	

Product-Specific Dimensions

E	D	X	Y
1.16 mm	1.56 mm	0.18 mm	0.18 mm



REV	DESCRIPTION	DATE	APP'D / SITE
1	Initial drawing release.	8-19-09	L. England / FSME

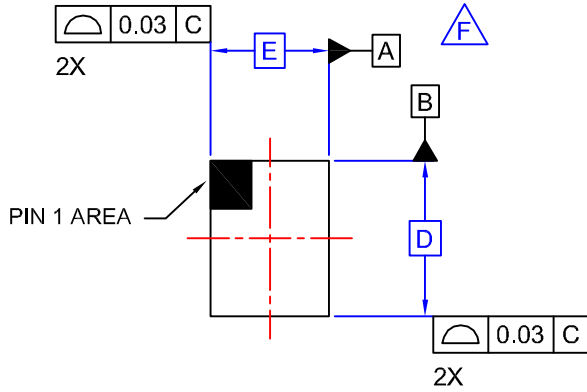

TOP VIEW

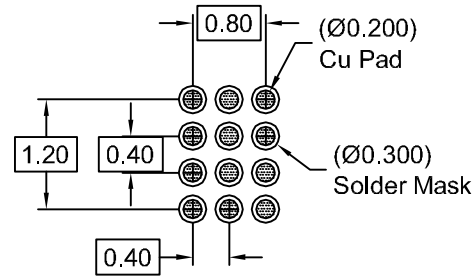

RECOMMENDED LAND PATTERN (NSMD PAD TYPE)

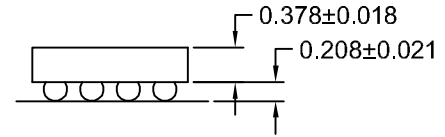
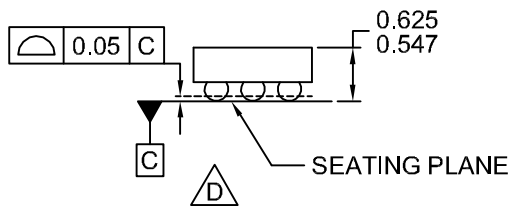

SIDE VIEWS

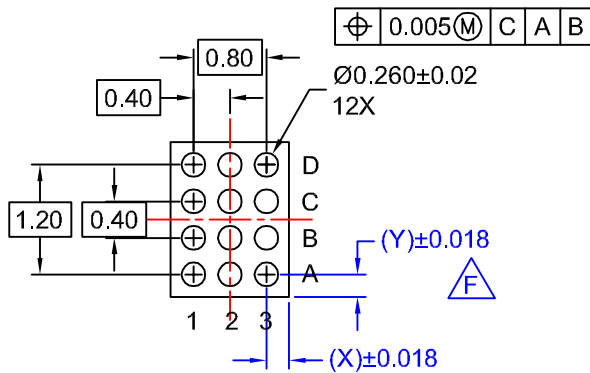

BOTTOM VIEW

NOTES:

- A. NO JEDEC REGISTRATION APPLIES.
- B. DIMENSIONS ARE IN MILLIMETERS.
- C. DIMENSIONS AND TOLERANCES PER ASME Y14.5M, 1994.
- D. DATUM C IS DEFINED BY THE SPHERICAL CROWNS OF THE BALLS.
- E. PACKAGE NOMINAL HEIGHT IS 586 MICRONS ±39 MICRONS (547-625 MICRONS).
- F. FOR DIMENSIONS D, E, X, AND Y SEE PRODUCT DATASHEET.
- G. DRAWING FILENAME: MKT-UC012ACrev1.

APPROVALS		DATE	FAIRCHILD SEMICONDUCTOR™			
DRAWN	L. England	8-19-09	12BALL WLCSP, 3X4 ARRAY 0.4MM PITCH, 250UM BALL			
DFTG. CHK.	S. Martin	8-19-09				
ENGR. CHK.						
			SCALE	SIZE	DRAWING NUMBER	REV
			N/A	N/A	MKT-UC012AC	1
			DO NOT SCALE DRAWING		SHEET 1 of 1	

ON Semiconductor and  are trademarks of Semiconductor Components Industries, LLC dba ON Semiconductor or its subsidiaries in the United States and/or other countries. ON Semiconductor owns the rights to a number of patents, trademarks, copyrights, trade secrets, and other intellectual property. A listing of ON Semiconductor's product/patent coverage may be accessed at www.onsemi.com/site/pdf/Patent-Marking.pdf. ON Semiconductor reserves the right to make changes without further notice to any products herein. ON Semiconductor makes no warranty, representation or guarantee regarding the suitability of its products for any particular purpose, nor does ON Semiconductor assume any liability arising out of the application or use of any product or circuit, and specifically disclaims any and all liability, including without limitation special, consequential or incidental damages. Buyer is responsible for its products and applications using ON Semiconductor products, including compliance with all laws, regulations and safety requirements or standards, regardless of any support or applications information provided by ON Semiconductor. "Typical" parameters which may be provided in ON Semiconductor data sheets and/or specifications can and do vary in different applications and actual performance may vary over time. All operating parameters, including "Typicals" must be validated for each customer application by customer's technical experts. ON Semiconductor does not convey any license under its patent rights nor the rights of others. ON Semiconductor products are not designed, intended, or authorized for use as a critical component in life support systems or any FDA Class 3 medical devices or medical devices with a same or similar classification in a foreign jurisdiction or any devices intended for implantation in the human body. Should Buyer purchase or use ON Semiconductor products for any such unintended or unauthorized application, Buyer shall indemnify and hold ON Semiconductor and its officers, employees, subsidiaries, affiliates, and distributors harmless against all claims, costs, damages, and expenses, and reasonable attorney fees arising out of, directly or indirectly, any claim of personal injury or death associated with such unintended or unauthorized use, even if such claim alleges that ON Semiconductor was negligent regarding the design or manufacture of the part. ON Semiconductor is an Equal Opportunity/Affirmative Action Employer. This literature is subject to all applicable copyright laws and is not for resale in any manner.

PUBLICATION ORDERING INFORMATION

LITERATURE FULFILLMENT:

Literature Distribution Center for ON Semiconductor
19521 E. 32nd Pkwy, Aurora, Colorado 80011 USA
Phone: 303-675-2175 or 800-344-3860 Toll Free USA/Canada
Fax: 303-675-2176 or 800-344-3867 Toll Free USA/Canada
Email: orderlit@onsemi.com

N. American Technical Support: 800-282-9855 Toll Free
USA/Canada
Europe, Middle East and Africa Technical Support:
Phone: 421 33 790 2910
Japan Customer Focus Center
Phone: 81-3-5817-1050

ON Semiconductor Website: www.onsemi.com

Order Literature: <http://www.onsemi.com/orderlit>

For additional information, please contact your local Sales Representative

OUR CERTIFICATE

DiGi provide top-quality products and perfect service for customer worldwide through standardization, technological innovation and continuous improvement. DiGi through third-party certification, we stricly control the quality of products and services. Welcome your RFQ to

Email: Info@DiGi-Electronics.com



Tel: +00 852-30501935

RFQ Email: Info@DiGi-Electronics.com

DiGi is a global authorized distributor of electronic components.