

FSBB10CH120D Datasheet

www.digi-electronics.com

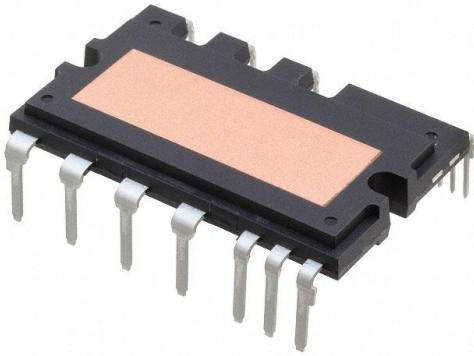

<https://www.DiGi-Electronics.com>

DiGi Electronics Part Number	FSBB10CH120D-DG
Manufacturer	onsemi
Manufacturer Product Number	FSBB10CH120D
Description	MODULE SPM 1.2V 10A 27PWRDIP
Detailed Description	Power Driver Module IGBT 3 Phase 1.2 kV 10 A 27-P overDIP Module (1.205", 30.60mm)

This model FSBB10CH120D is available at DiGi Electronics.

DiGi Electronics offers a global database of semiconductor and electronic component datasheets.

We welcome your inquiries regarding pricing, lead time, or other product-related questions.

 [Request a Quote](#)

 [Datasheet Search](#)



Tel: +00 852-30501935

RFQ Email: Info@DiGi-Electronics.com

DiGi is a global authorized distributor of electronic components.

Purchase and inquiry

Manufacturer Product Number:

FSBB10CH120D

Series:

Motion SPM® 3

Type:

IGBT

Current:

10 A

Voltage - Isolation:

2500Vrms

Package / Case:

27-PowerDIP Module (1.205", 30.60mm)

Manufacturer:

onsemi

Product Status:

Not For New Designs

Configuration:

3 Phase

Voltage:

1.2 kV

Mounting Type:

Through Hole

Base Product Number:

FSBB10

Environmental & Export classification

RoHS Status:

ROHS3 Compliant

REACH Status:

REACH Unaffected

HTSUS:

8542.39.0001

Moisture Sensitivity Level (MSL):

Not Applicable

ECCN:

EAR99



Is Now Part of



ON Semiconductor®

To learn more about ON Semiconductor, please visit our website at
www.onsemi.com

Please note: As part of the Fairchild Semiconductor integration, some of the Fairchild orderable part numbers will need to change in order to meet ON Semiconductor's system requirements. Since the ON Semiconductor product management systems do not have the ability to manage part nomenclature that utilizes an underscore (_), the underscore (_) in the Fairchild part numbers will be changed to a dash (-). This document may contain device numbers with an underscore (_). Please check the ON Semiconductor website to verify the updated device numbers. The most current and up-to-date ordering information can be found at www.onsemi.com. Please email any questions regarding the system integration to Fairchild_questions@onsemi.com.

ON Semiconductor and the ON Semiconductor logo are trademarks of Semiconductor Components Industries, LLC dba ON Semiconductor or its subsidiaries in the United States and/or other countries. ON Semiconductor owns the rights to a number of patents, trademarks, copyrights, trade secrets, and other intellectual property. A listing of ON Semiconductor's product/patent coverage may be accessed at www.onsemi.com/site/pdf/Patent-Marking.pdf. ON Semiconductor reserves the right to make changes without further notice to any products herein. ON Semiconductor makes no warranty, representation or guarantee regarding the suitability of its products for any particular purpose, nor does ON Semiconductor assume any liability arising out of the application or use of any product or circuit, and specifically disclaims any and all liability, including without limitation special, consequential or incidental damages. Buyer is responsible for its products and applications using ON Semiconductor products, including compliance with all laws, regulations and safety requirements or standards, regardless of any support or applications information provided by ON Semiconductor. "Typical" parameters which may be provided in ON Semiconductor data sheets and/or specifications can and do vary in different applications and actual performance may vary over time. All operating parameters, including "Typicals" must be validated for each customer application by customer's technical experts. ON Semiconductor does not convey any license under its patent rights nor the rights of others. ON Semiconductor products are not designed, intended, or authorized for use as a critical component in life support systems or any FDA Class 3 medical devices or medical devices with a same or similar classification in a foreign jurisdiction or any devices intended for implantation in the human body. Should Buyer purchase or use ON Semiconductor products for any such unintended or unauthorized application, Buyer shall indemnify and hold ON Semiconductor and its officers, employees, subsidiaries, affiliates, and distributors harmless against all claims, costs, damages, and expenses, and reasonable attorney fees arising out of, directly or indirectly, any claim of personal injury or death associated with such unintended or unauthorized use, even if such claim alleges that ON Semiconductor was negligent regarding the design or manufacture of the part. ON Semiconductor is an Equal Opportunity/Affirmative Action Employer. This literature is subject to all applicable copyright laws and is not for resale in any manner.



FSBB10CH120D

Motion SPM[®] 3 Series

Features

- UL Certified No. E209204 (UL1557)
- 1200 V - 10 A 3-Phase IGBT Inverter with Integral Gate Drivers and Protection
- Low-Loss, Short-Circuit Rated IGBTs
- Very Low Thermal Resistance Using Al₂O₃ DBC Substrate
- Dedicated Vs Pins Simplify PCB Layout
- Separate Open-Emitter Pins from Low-Side IGBTs for Three-Phase Current Sensing
- Single-Grounded Power Supply
- LVIC Temperature-Sensing Built-In for Temperature Monitoring
- Isolation Rating: 2500 V_{rms} / 1 min.

Applications

- Motion Control - Industrial Motor (AC 400V Class)

Related Resources

- [AN-9095 - Motion SPM[®] 3 Series User's Guide](#)
- [AN-9086 - SPM[®] 3 Package Mounting Guidance](#)

General Description

FSBB10CH120D is an advanced Motion SPM[®] 3 module providing a fully-featured, high-performance inverter output stage for AC Induction, BLDC, and PMSM motors. These modules integrate optimized gate drive of the built-in IGBTs to minimize EMI and losses, while also providing multiple on-module protection features including under-voltage lockouts, over-current shutdown, thermal monitoring of drive IC, and fault reporting. The built-in, high-speed HVIC requires only a single supply voltage and translates the incoming logic-level gate inputs to the high-voltage, high-current drive signals required to properly drive the module's internal IGBTs. Separate negative IGBT terminals are available for each phase to support the widest variety of control algorithms.



Figure 1. 3D Package Drawing
(Click to Activate 3D Content)

Package Marking and Ordering Information

Device	Device Marking	Package	Packing Type	Quantity
FSBB10CH120D	FSBB10CH120D	SPMMC-027	Rail	10

Integrated Power Functions

- 1200 V - 10 A IGBT inverter for three-phase DC / AC power conversion (Please refer to Figure 3)

Integrated Drive, Protection and System Control Functions

- For inverter high-side IGBTs: gate drive circuit, high-voltage isolated high-speed level shifting control circuit Under-Voltage Lock-Out Protection (UVLO)
Note: Available bootstrap circuit example is given in Figures 5 and 15.
- For inverter low-side IGBTs: gate drive circuit, Short-Circuit Protection (SCP) control supply circuit Under-Voltage Lock-Out Protection (UVLO)
- Fault signaling: corresponding to UVLO (low-side supply) and SC faults
- Input interface: active-HIGH interface, works with 3.3 / 5 V logic, Schmitt-trigger input

Pin Configuration

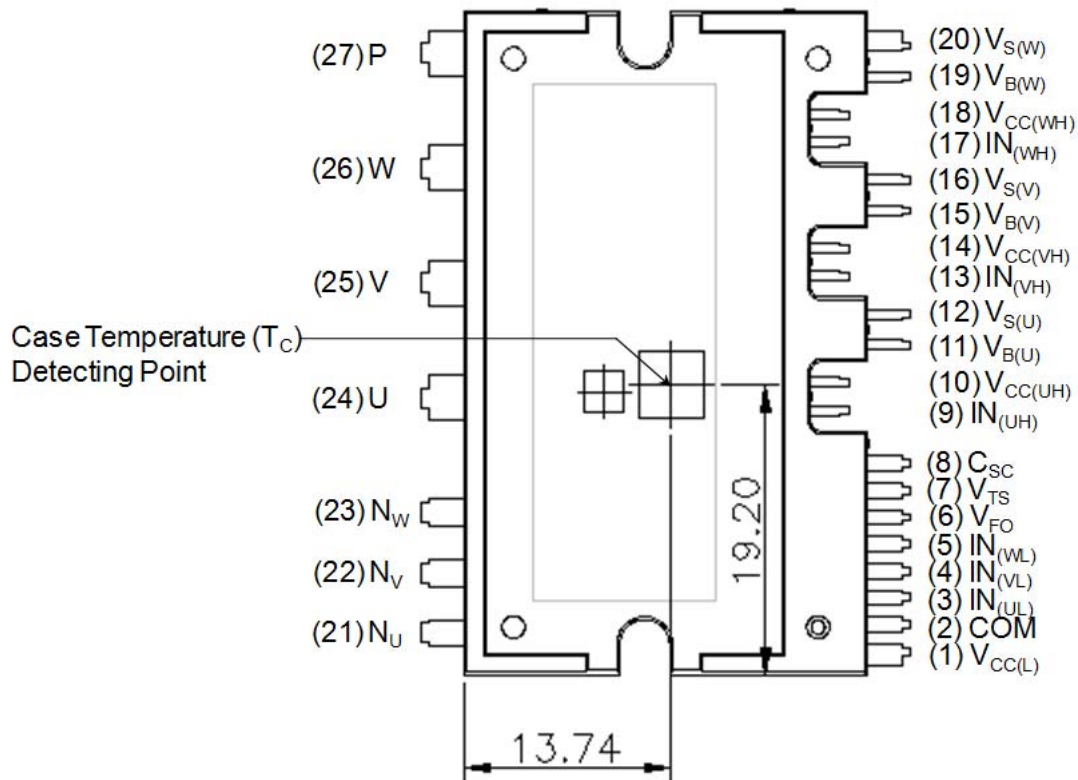

Figure 2. Top View

Pin Descriptions

Pin Number	Pin Name	Pin Description
1	$V_{CC(L)}$	Low-Side Common Bias Voltage for IC and IGBTs Driving
2	COM	Common Supply Ground
3	$IN_{(UL)}$	Signal Input for Low-Side U Phase
4	$IN_{(VL)}$	Signal Input for Low-Side V Phase
5	$IN_{(WL)}$	Signal Input for Low-Side W Phase
6	V_{FO}	Fault Output
7	V_{TS}	Output for LVIC Temperature Sensing Voltage Output
8	C_{SC}	Capacitor (Low-Pass Filter) for Short-Circuit Current Detection Input
9	$IN_{(UH)}$	Signal Input for High-Side U Phase
10	$V_{CC(UH)}$	High-Side Bias Voltage for U Phase IC
11	$V_{B(U)}$	High-Side Bias Voltage for U Phase IGBT Driving
12	$V_{S(U)}$	High-Side Bias Voltage Ground for U Phase IGBT Driving
13	$IN_{(VH)}$	Signal Input for High-Side V Phase
14	$V_{CC(VH)}$	High-Side Bias Voltage for V Phase IC
15	$V_{B(V)}$	High-Side Bias Voltage for V Phase IGBT Driving
16	$V_{S(V)}$	High-Side Bias Voltage Ground for V Phase IGBT Driving
17	$IN_{(WH)}$	Signal Input for High-Side W Phase
18	$V_{CC(WH)}$	High-Side Bias Voltage for W Phase IC
19	$V_{B(W)}$	High-Side Bias Voltage for W Phase IGBT Driving
20	$V_{S(W)}$	High-Side Bias Voltage Ground for W Phase IGBT Driving
21	N_U	Negative DC-Link Input for U Phase
22	N_V	Negative DC-Link Input for V Phase
23	N_W	Negative DC-Link Input for W Phase
24	U	Output for U Phase
25	V	Output for V Phase
26	W	Output for W Phase
27	P	Positive DC-Link Input

Internal Equivalent Circuit and Input/Output Pins

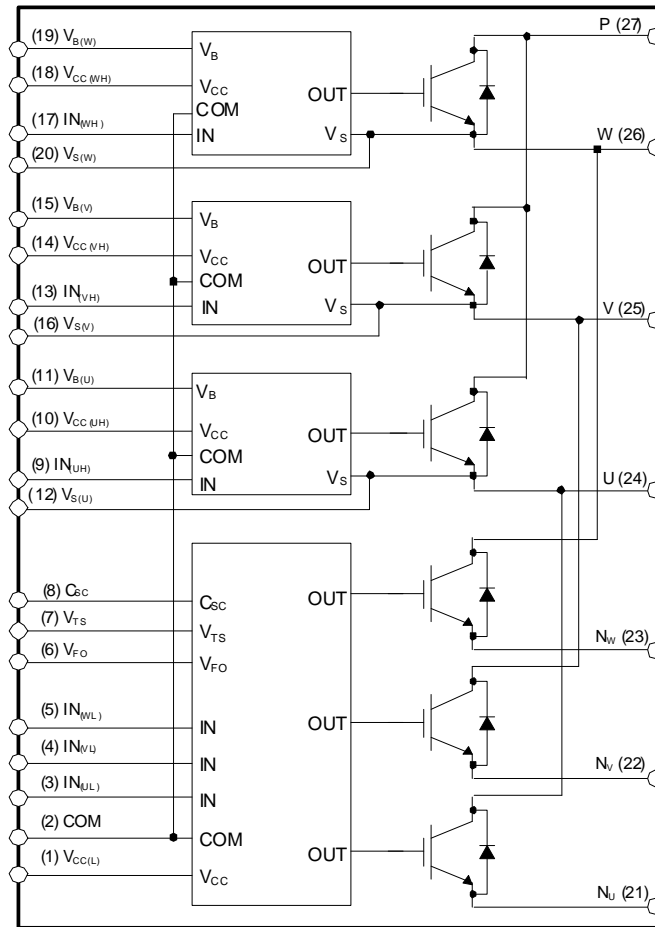

Figure 3. Internal Block Diagram

Notes:

1. Inverter low-side is composed of three IGBTs, freewheeling diodes for each IGBT, and one control IC. It has gate drive and protection functions.
2. Inverter power side is composed of four inverter DC-link input terminals and three inverter output terminals.
3. Inverter high-side is composed of three IGBTs, freewheeling diodes, and three drive ICs for each IGBT.

Absolute Maximum Ratings ($T_J = 25^\circ\text{C}$, Unless Otherwise Specified)**Inverter Part**

Symbol	Parameter	Conditions	Rating	Unit
V_{PN}	Supply Voltage	Applied between P - N_U , N_V , N_W	900	V
$V_{PN(\text{Surge})}$	Supply Voltage (Surge)	Applied between P - N_U , N_V , N_W	1000	V
V_{CES}	Collector - Emitter Voltage		1200	V
$\pm I_C$	Each IGBT Collector Current	$T_C = 25^\circ\text{C}$, $T_J \leq 150^\circ\text{C}$ (Note 4)	10	A
$\pm I_{CP}$	Each IGBT Collector Current (Peak)	$T_C = 25^\circ\text{C}$, $T_J \leq 150^\circ\text{C}$, Under 1 ms Pulse Width (Note 4)	20	A
P_C	Collector Dissipation	$T_C = 25^\circ\text{C}$ per One Chip (Note 4)	69	W
T_J	Operating Junction Temperature		-40 ~ 150	$^\circ\text{C}$

Control Part

Symbol	Parameter	Conditions	Rating	Unit
V_{CC}	Control Supply Voltage	Applied between $V_{CC(H)}$, $V_{CC(L)}$ - COM	20	V
V_{BS}	High-Side Control Bias Voltage	Applied between $V_{B(U)} - V_{S(U)}$, $V_{B(V)} - V_{S(V)}$, $V_{B(W)} - V_{S(W)}$	20	V
V_{IN}	Input Signal Voltage	Applied between $IN_{(UH)}$, $IN_{(VH)}$, $IN_{(WH)}$, $IN_{(UL)}$, $IN_{(VL)}$, $IN_{(WL)}$ - COM	-0.3 ~ $V_{CC}+0.3$	V
V_{FO}	Fault Output Supply Voltage	Applied between V_{FO} - COM	-0.3 ~ $V_{CC}+0.3$	V
I_{FO}	Fault Output Current	Sink Current at V_{FO} pin	2	mA
V_{SC}	Current Sensing Input Voltage	Applied between C_{SC} - COM	-0.3 ~ $V_{CC}+0.3$	V

Total System

Symbol	Parameter	Conditions	Rating	Unit
$V_{PN(\text{PROT})}$	Self Protection Supply Voltage Limit (Short Circuit Protection Capability)	$V_{CC} = V_{BS} = 13.5 \sim 16.5 \text{ V}$, $T_J = 150^\circ\text{C}$, Non-repetitive, $< 2 \mu\text{s}$	800	V
T_C	Module Case Operation Temperature	See Figure 2	-40 ~ 125	$^\circ\text{C}$
T_{STG}	Storage Temperature		-40 ~ 125	$^\circ\text{C}$
V_{ISO}	Isolation Voltage	60 Hz, Sinusoidal, AC 1 minute, Connection Pins to Heat Sink Plate	2500	V_{rms}

Thermal Resistance

Symbol	Parameter	Conditions	Min.	Typ.	Max.	Unit
$R_{th(j-c)Q}$	Junction to Case Thermal Resistance (Note 5)	Inverter IGBT part (per 1 / 6 module)	-	-	1.80	$^\circ\text{C} / \text{W}$
$R_{th(j-c)F}$		Inverter FWD part (per 1 / 6 module)	-	-	2.75	$^\circ\text{C} / \text{W}$

Note:

- These values had been made an acquisition by the calculation considered to design factor.
- For the measurement point of case temperature (T_C), please refer to Figure 2.

Electrical Characteristics ($T_J = 25^\circ\text{C}$, Unless Otherwise Specified)

Inverter Part

Symbol	Parameter	Conditions	Min.	Typ.	Max.	Unit
$V_{CE(SAT)}$	Collector - Emitter Saturation Voltage	$V_{CC} = V_{BS} = 15\text{ V}$ $V_{IN} = 5\text{ V}$	-	2.20	2.80	V
V_F	FWDI Forward Voltage	$V_{IN} = 0\text{ V}$ $I_F = 10\text{ A}, T_J = 25^\circ\text{C}$	-	2.20	2.80	V
HS	t_{ON} $t_{C(ON)}$ t_{OFF} $t_{C(OFF)}$ t_{rr}	Switching Times $V_{PN} = 600\text{ V}, V_{CC} = 15\text{ V}, I_C = 10\text{ A}$ $T_J = 25^\circ\text{C}$ $V_{IN} = 0\text{ V} \leftrightarrow 5\text{ V}$, Inductive Load See Figure 5 (Note 6)	0.45	0.85	1.35	μs
			-	0.25	0.60	μs
			-	0.95	1.50	μs
			-	0.10	0.45	μs
			-	0.25	-	μs
LS	t_{ON} $t_{C(ON)}$ t_{OFF} $t_{C(OFF)}$ t_{rr}	$V_{PN} = 600\text{ V}, V_{CC} = 15\text{ V}, I_C = 10\text{ A}$ $T_J = 25^\circ\text{C}$ $V_{IN} = 0\text{ V} \leftrightarrow 5\text{ V}$, Inductive Load See Figure 5 (Note 6)	0.35	0.75	1.25	μs
			-	0.20	0.55	μs
			-	0.95	1.50	μs
			-	0.10	0.45	μs
			-	0.20	-	μs
I_{CES}	Collector - Emitter Leakage Current	$V_{CE} = V_{CES}$	-	-	5	mA

Note:

6. t_{ON} and t_{OFF} include the propagation delay time of the internal drive IC. $t_{C(ON)}$ and $t_{C(OFF)}$ are the switching time of IGBT itself under the given gate driving condition internally. For the detailed information, please see Figure 4.

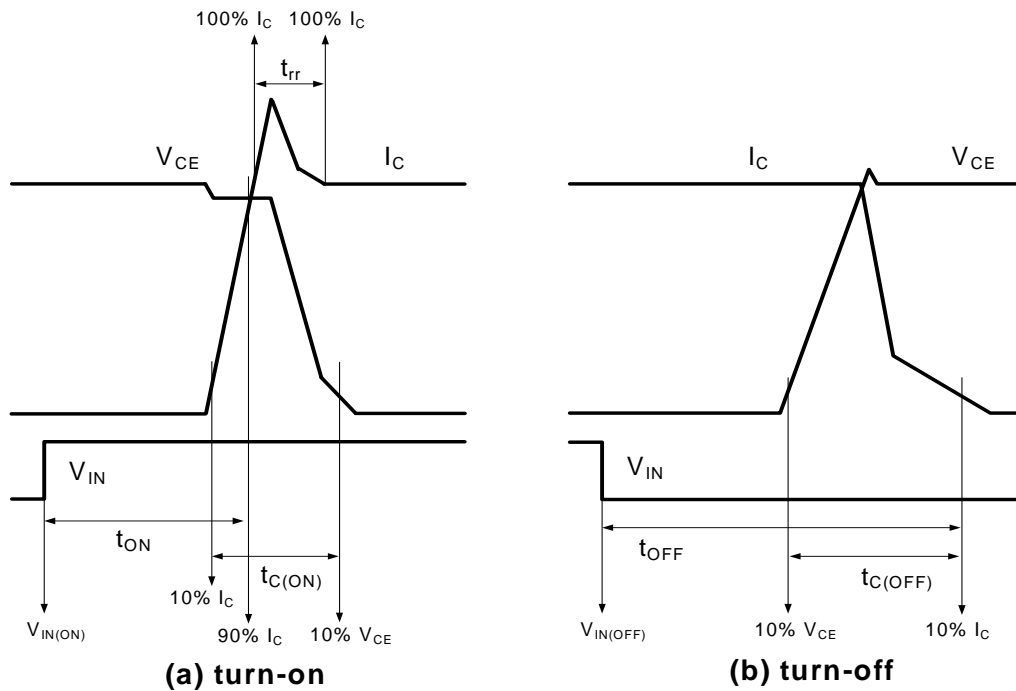

Figure 4. Switching Time Definition

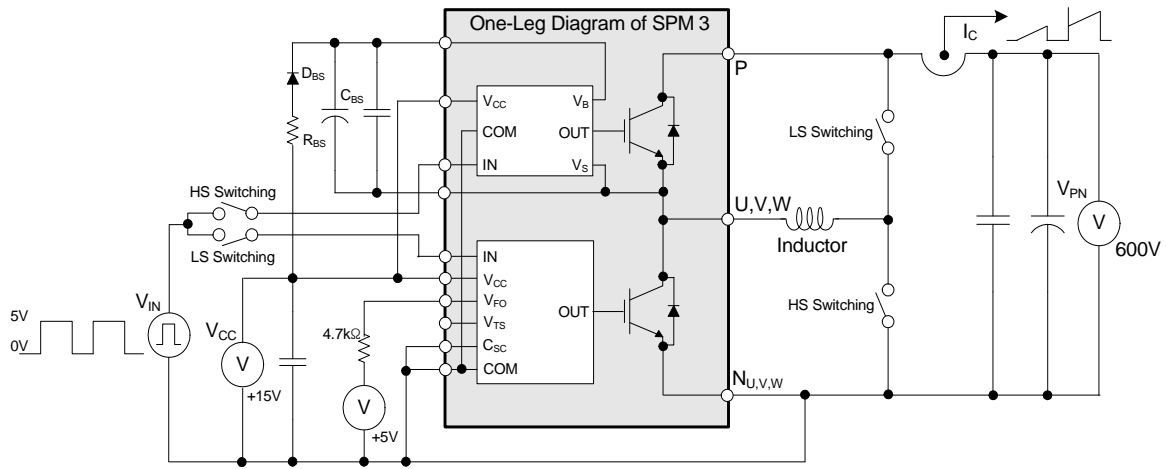

Figure 5. Example Circuit for Switching Test

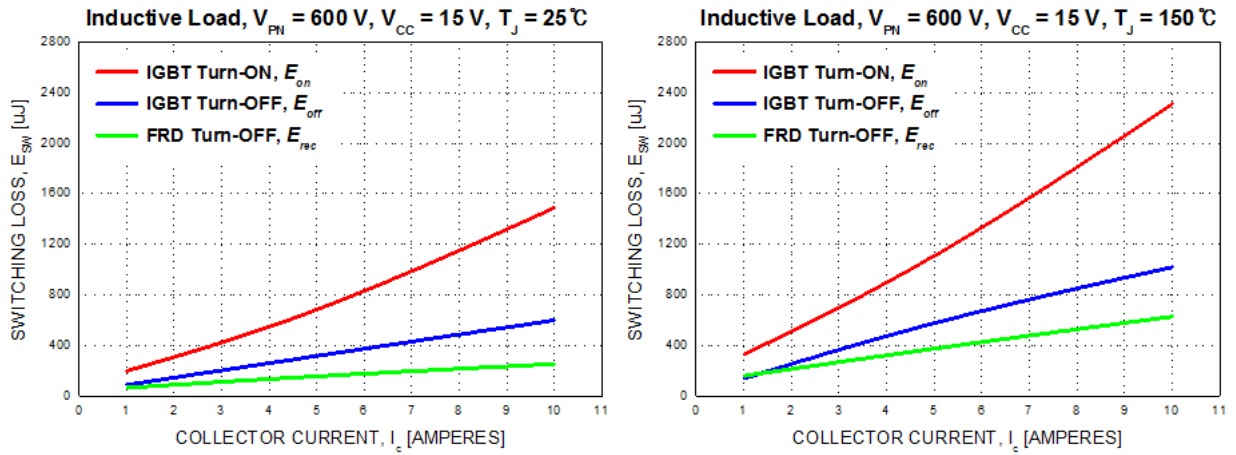

Figure 6. Switching Loss Characteristics

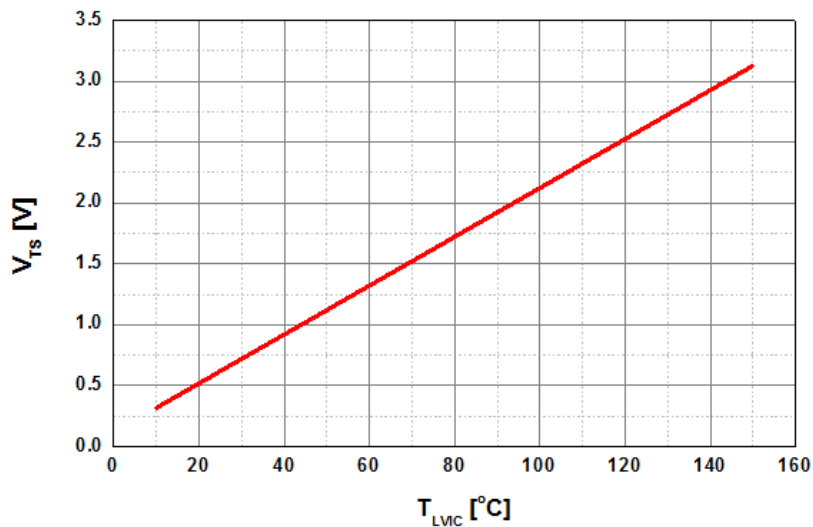

Figure 7. Temperature Profile of V_{TS} (Typical)

Control Part

Symbol	Parameter	Conditions	Min.	Typ.	Max.	Unit
I _{QCCH}	Quiescent V _{CC} Supply Current	V _{CC(UH,VH,WH)} = 15 V, I _{N(UH,VH,WH)} = 0 V	-	-	0.15	mA
I _{QCCL}		V _{CC(L)} = 15 V, I _{N(UL,VL,WL)} = 0 V	-	-	5.00	mA
I _{PCCH}	Operating V _{CC} Supply Current	V _{CC(UH,VH,WH)} = 15 V, f _{PWM} = 20 kHz, duty = 50%, applied to one PWM signal input for High-Side	-	-	0.30	mA
I _{PCCL}		V _{CC(L)} = 15V, f _{PWM} = 20 kHz, duty = 50%, applied to one PWM signal input for Low-Side	-	-	8.50	mA
I _{QBS}	Quiescent V _{BS} Supply Current	V _{BS} = 15 V, I _{N(UH, VH, WH)} = 0 V	-	-	0.30	mA
I _{PBS}	Operating V _{BS} Supply Current	V _{CC} = V _{BS} = 15 V, f _{PWM} = 20 kHz, duty = 50%, applied to one PWM signal input for High-Side	-	-	4.50	mA
V _{FOH}	Fault Output Voltage	V _{CC} = 15 V, V _{SC} = 0 V, V _{FO} Circuit: 4.7 kΩ to 5 V Pull-up	4.5	-	-	V
V _{FOL}		V _{CC} = 15 V, V _{SC} = 1 V, V _{FO} Circuit: 4.7 kΩ to 5 V Pull-up	-	-	0.5	V
V _{SC(ref)}	Short Circuit Trip Level	V _{CC} = 15 V (Note 7)	0.43	0.50	0.57	V
UV _{CCD}	Supply Circuit Under-Voltage Protection	Detection Level	10.3	-	12.8	V
UV _{CCR}		Reset Level	10.8	-	13.3	V
UV _{BSD}		Detection Level	9.5	-	12.0	V
UV _{BSR}		Reset Level	10.0	-	12.5	V
t _{FOD}	Fault-Out Pulse Width		50	-	-	μs
V _{TS}	LVIC Temperature Sensing Voltage Output	V _{CC(L)} = 15 V, T _{LVIC} = 25°C (Note 8) See Figure 7	540	640	740	mV
V _{IN(ON)}	ON Threshold Voltage	Applied between I _{N(UH, VH, WH)} - COM, I _{N(UL, VL, WL)} - COM	-	-	2.6	V
V _{IN(OFF)}	OFF Threshold Voltage		0.8	-	-	V

Note:

- 7. Short-circuit current protection is functioning only at the low - sides.
- 8. T_{LVIC} is the temperature of LVIC itself. V_{TS} is only for sensing temperature of LVIC and can not shutdown IGBTs automatically.

Recommended Operating Conditions

Symbol	Parameter	Conditions	Value			Unit
			Min.	Typ.	Max.	
V _{PN}	Supply Voltage	Applied between P - N _U , N _V , N _W	300	600	800	V
V _{CC}	Control Supply Voltage	Applied between V _{CC(UH, VH, WH)} - COM, V _{CC(L)} - COM	13.5	15.0	16.5	V
V _{BS}	High-Side Bias Voltage	Applied between V _{B(U)} - V _{S(U)} , V _{B(V)} - V _{S(V)} , V _{B(W)} - V _{S(W)}	13.0	15.0	18.5	V
dV _{CC} /dt, dV _{BS} /dt	Control Supply Variation		-1	-	1	V/μs
t _{dead}	Blanking Time for Preventing Arm - Short	For Each Input Signal	2.0	-	-	μs
f _{PWM}	PWM Input Signal	-40°C ≤ T _C ≤ 125°C, -40°C ≤ T _J ≤ 150°C	-	-	20	kHz
V _{SEN}	Voltage for Current Sensing	Applied between N _U , N _V , N _W - COM (Including Surge Voltage)	-5		5	V
PW _{IN(ON)}	Minimum Input Pulse Width	I _C ≤ 20 A, Wiring Inductance between N _U , v, w and DC Link N < 10nH (Note 9)	1.5	-	-	μs
PW _{IN(OFF)}			1.5	-	-	
T _J	Junction Temperature		-40	-	150	°C

Note:

9. This product might not make response if input pulse width is less than the recommended value.

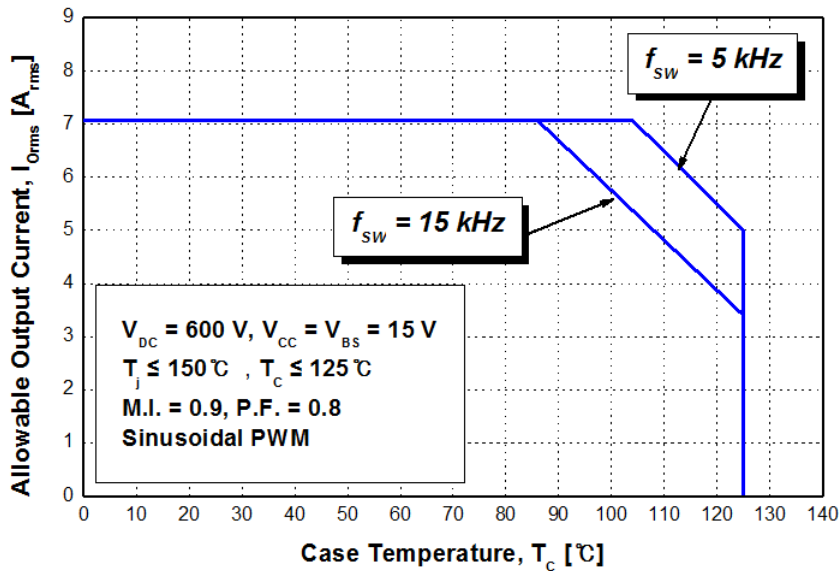

Figure 8. Allowable Maximum Output Current

Note:

10. This allowable output current value is the reference data for the safe operation of this product. This may be different from the actual application and operating condition.

Mechanical Characteristics and Ratings

Parameter	Conditions	Limits			Unit
		Min.	Typ.	Max.	
Device Flatness	See Figure 9	0	-	+150	μm
Mounting Torque	Mounting Screw: M3	Recommended 0.7 N • m			N • m
	See Figure 10	Recommended 7.1 kg • cm			kg • cm
Terminal Pulling Strength	Load 19.6 N	10	-	-	s
Terminal Bending Strength	Load 9.8 N, 90 deg. bend	2	-	-	times
Weight		-	15	-	g

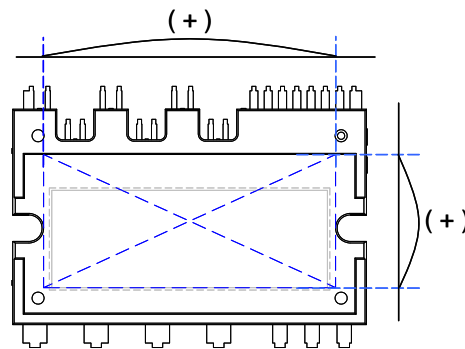

Figure 9. Flatness Measurement Position

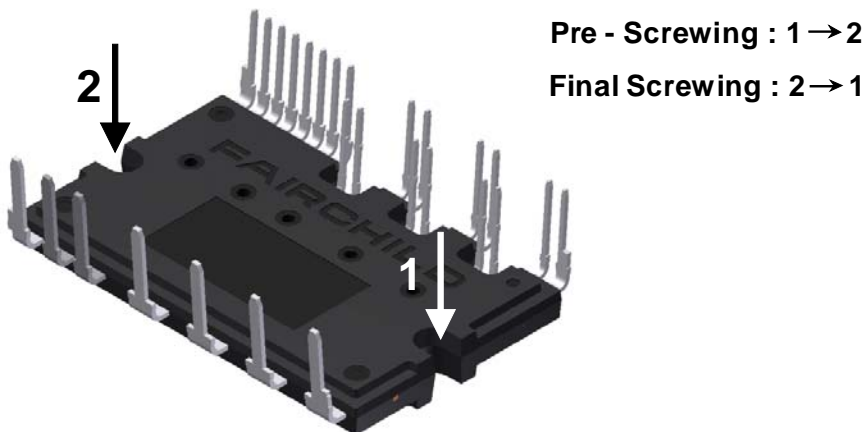

Figure 10. Mounting Screws Torque Order

Note:

- 11. Do not make over torque when mounting screws. Much mounting torque may cause DBC cracks, as well as bolts and Al heat - sink destruction.
- 12. Avoid one side tightening stress. Figure 10 shows the recommended torque order for mounting screws. Uneven mounting can cause the ceramic substrate of the Motion SPM 3 product to be damaged. The Pre - Screwing torque is set to 20 ~ 30% of maximum torque rating.

Time Charts of SPMs Protective Function

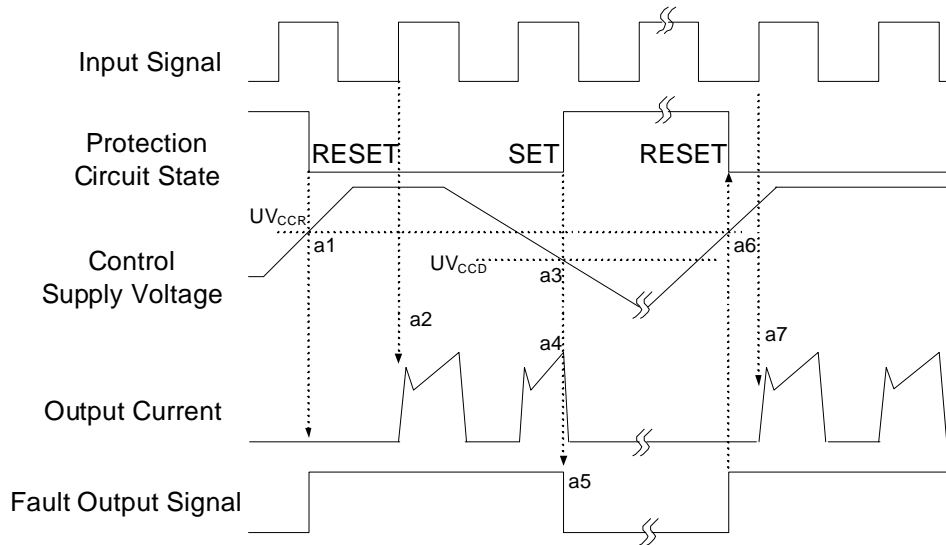

Figure 11. Under-Voltage Protection (Low-Side)

- a1 : Control supply voltage rises: After the voltage rises UV_{CCR} , the circuits start to operate when next input is applied.
- a2 : Normal operation: IGBT ON and carrying current.
- a3 : Under voltage detection (UV_{CCD}).
- a4 : IGBT OFF in spite of control input condition.
- a5 : Fault output operation starts fixed pulse width or until control supply voltage is recovered up to UV_{CCR} .
- a6 : Under voltage reset (UV_{CCR}).
- a7 : Normal operation: IGBT ON and carrying current by triggering next signal from "LOW" to "HIGH".

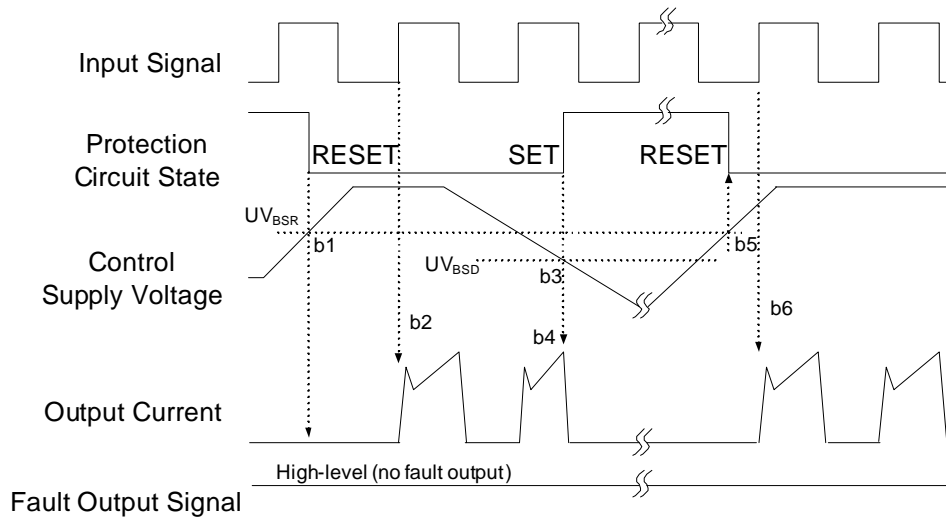

Figure 12. Under-Voltage Protection (High-Side)

- b1 : Control supply voltage rises: After the voltage reaches UV_{BSR} , the circuits start to operate when next input is applied.
- b2 : Normal operation: IGBT ON and carrying current.
- b3 : Under voltage detection (UV_{BSD}).
- b4 : IGBT OFF in spite of control input condition, but there is no fault output signal.
- b5 : Under voltage reset (UV_{BSR}).
- b6 : Normal operation: IGBT ON and carrying current by triggering next signal from "LOW" to "HIGH".

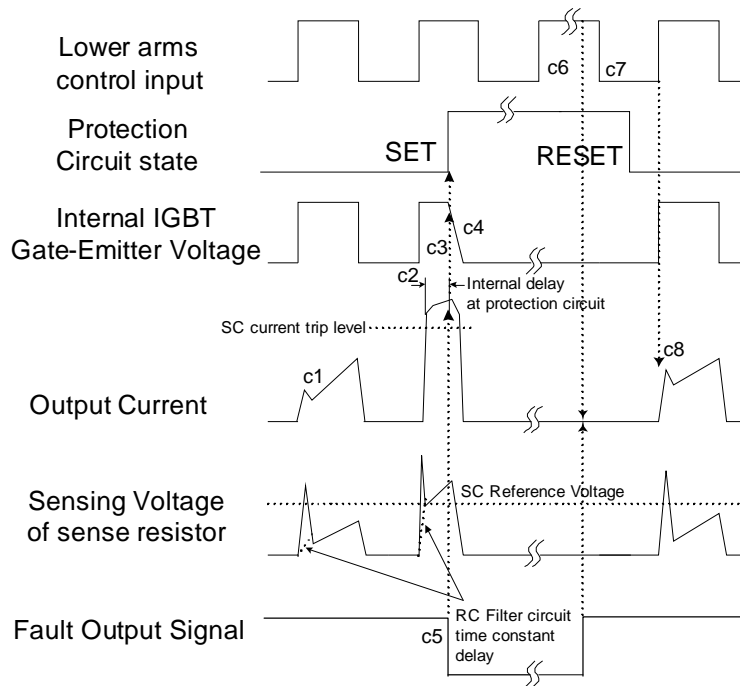

Figure 13. Short-Circuit Current Protection (Low-Side Operation only)

(with the external sense resistance and RC filter connection)

- c1 : Normal operation: IGBT ON and carrying current.
- c2 : Short circuit current detection (SC trigger).
- c3 : All low-side IGBT's gate are hard interrupted.
- c4 : All low-side IGBTs turn OFF.
- c5 : Fault output operation starts with a fixed pulse width.
- c6 : Input "HIGH": IGBT ON state, but during the active period of fault output the IGBT doesn't turn ON.
- c7 : Fault output operation finishes, but IGBT don't turn on until triggering next signal from "LOW" to "HIGH".
- c8 : Normal operation: IGBT ON and carrying current.

Input/Output Interface Circuit

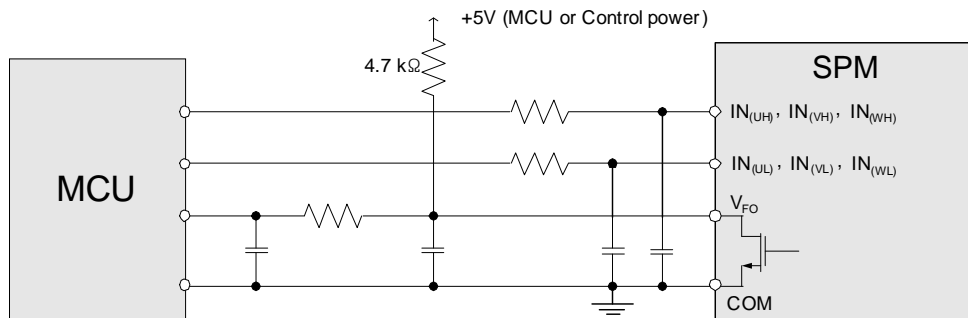
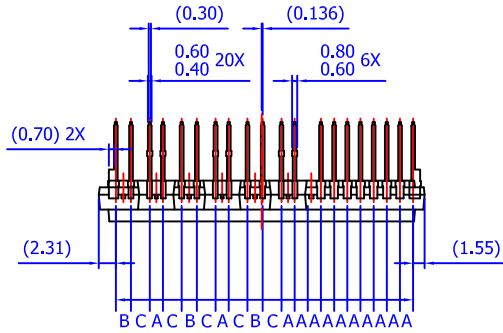

Figure 14. Recommended CPU I/O Interface Circuit

Note:

13. RC coupling at each input (parts shown dotted) might change depending on the PWM control scheme used in the application and the wiring impedance of the application's printed circuit board. The input signal section of the Motion SPM 3 product integrates 5 kΩ (typ.) pull - down resistor. Therefore, when using an external filtering resistor, please pay attention to the signal voltage drop at input terminal.



LEAD PITCH (TOLERANCE : ±0.30)
 A : 1.778
 B : 2.050
 C : 2.531

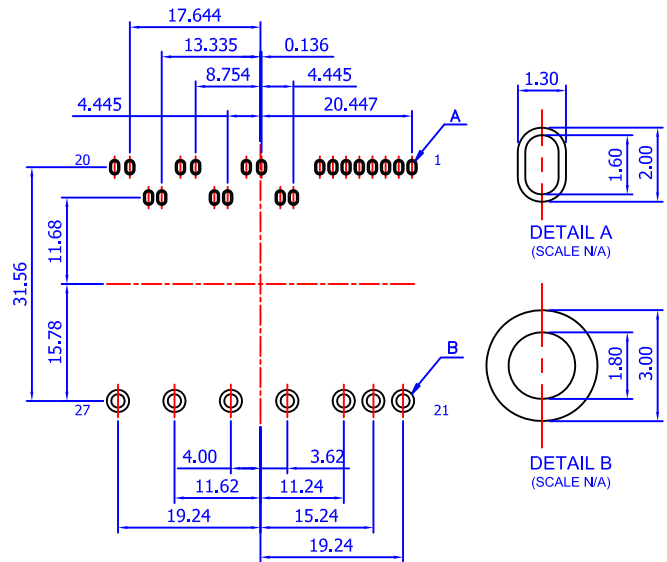
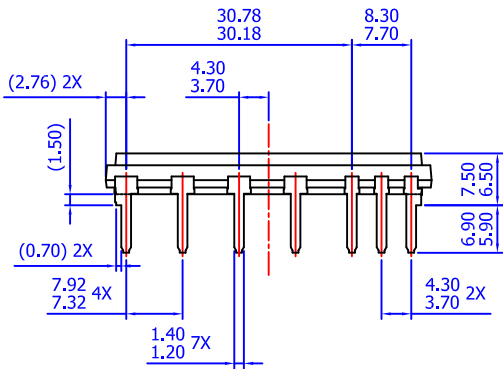
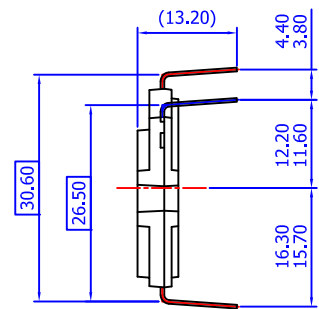
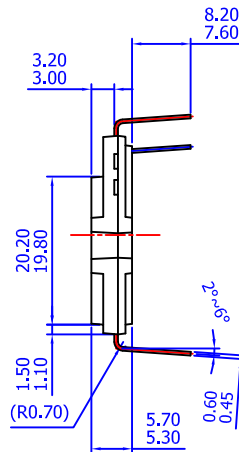
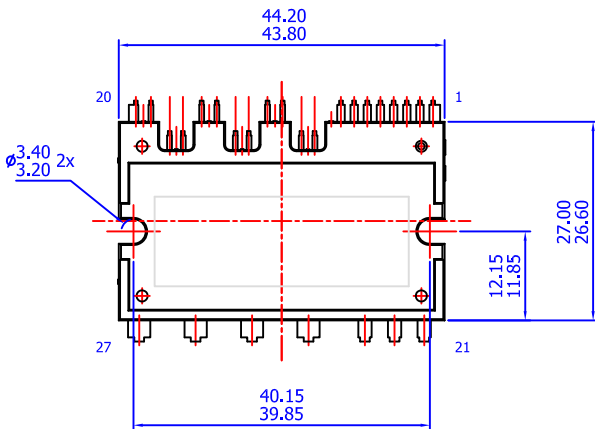

- NOTES: UNLESS OTHERWISE SPECIFIED
 A) THIS PACKAGE DOES NOT COMPLY TO ANY CURRENT PACKAGING STANDARD
 B) ALL DIMENSIONS ARE IN MILLIMETERS
 C) DIMENSIONS ARE EXCLUSIVE OF BURRS, MOLD FLASH, AND TIE BAR EXTRUSIONS
 D) () IS REFERENCE
 E) [] IS ASSY QUALITY
 F) DRAWING FILENAME: MOD27BAREV3
 G) FAIRCHILD SEMICONDUCTOR

LAND PATTERN RECOMMENDATIONS



ON Semiconductor and  are trademarks of Semiconductor Components Industries, LLC dba ON Semiconductor or its subsidiaries in the United States and/or other countries. ON Semiconductor owns the rights to a number of patents, trademarks, copyrights, trade secrets, and other intellectual property. A listing of ON Semiconductor's product/patent coverage may be accessed at www.onsemi.com/site/pdf/Patent-Marking.pdf. ON Semiconductor reserves the right to make changes without further notice to any products herein. ON Semiconductor makes no warranty, representation or guarantee regarding the suitability of its products for any particular purpose, nor does ON Semiconductor assume any liability arising out of the application or use of any product or circuit, and specifically disclaims any and all liability, including without limitation special, consequential or incidental damages. Buyer is responsible for its products and applications using ON Semiconductor products, including compliance with all laws, regulations and safety requirements or standards, regardless of any support or applications information provided by ON Semiconductor. "Typical" parameters which may be provided in ON Semiconductor data sheets and/or specifications can and do vary in different applications and actual performance may vary over time. All operating parameters, including "Typicals" must be validated for each customer application by customer's technical experts. ON Semiconductor does not convey any license under its patent rights nor the rights of others. ON Semiconductor products are not designed, intended, or authorized for use as a critical component in life support systems or any FDA Class 3 medical devices or medical devices with a same or similar classification in a foreign jurisdiction or any devices intended for implantation in the human body. Should Buyer purchase or use ON Semiconductor products for any such unintended or unauthorized application, Buyer shall indemnify and hold ON Semiconductor and its officers, employees, subsidiaries, affiliates, and distributors harmless against all claims, costs, damages, and expenses, and reasonable attorney fees arising out of, directly or indirectly, any claim of personal injury or death associated with such unintended or unauthorized use, even if such claim alleges that ON Semiconductor was negligent regarding the design or manufacture of the part. ON Semiconductor is an Equal Opportunity/Affirmative Action Employer. This literature is subject to all applicable copyright laws and is not for resale in any manner.

PUBLICATION ORDERING INFORMATION

LITERATURE FULFILLMENT:

Literature Distribution Center for ON Semiconductor
19521 E. 32nd Pkwy, Aurora, Colorado 80011 USA
Phone: 303-675-2175 or 800-344-3860 Toll Free USA/Canada
Fax: 303-675-2176 or 800-344-3867 Toll Free USA/Canada
Email: orderlit@onsemi.com

N. American Technical Support: 800-282-9855 Toll Free
USA/Canada
Europe, Middle East and Africa Technical Support:
Phone: 421 33 790 2910
Japan Customer Focus Center
Phone: 81-3-5817-1050

ON Semiconductor Website: www.onsemi.com

Order Literature: <http://www.onsemi.com/orderlit>

For additional information, please contact your local Sales Representative

OUR CERTIFICATE

DiGi provide top-quality products and perfect service for customer worldwide through standardization, technological innovation and continuous improvement. DiGi through third-party certification, we strictly control the quality of products and services. Welcome your RFQ to

Email: Info@DiGi-Electronics.com



Tel: +00 852-30501935

RFQ Email: Info@DiGi-Electronics.com

DiGi is a global authorized distributor of electronic components.