

# FST3244QSCX Datasheet

[www.digi-electronics.com](http://www.digi-electronics.com)

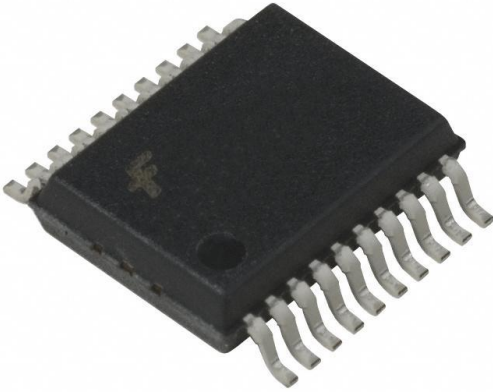

FST3244QSCX

<https://www.DiGi-Electronics.com>

DiGi Electronics Part Number	FST3244QSCX-DG
Manufacturer	<a href="#">onsemi</a>
Manufacturer Product Number	FST3244QSCX
Description	IC BUS SWITCH 4 X 1:1 20QSOP
Detailed Description	Bus Switch 4 x 1:1 20-QSOP



Tel: +00 852-30501935

RFQ Email: [Info@DiGi-Electronics.com](mailto:Info@DiGi-Electronics.com)

DiGi is a global authorized distributor of electronic components.

## Purchase and inquiry

Manufacturer Product Number:

FST3244QSCX

Series:

-

Type:

Bus Switch

Independent Circuits:

2

Voltage Supply Source:

Single Supply

Operating Temperature:

-40°C ~ 85°C

Package / Case:

20-LSSOP (0.154", 3.90mm Width)

Base Product Number:

FST32

Manufacturer:

onsemi

Product Status:

Obsolete

Circuit:

4 x 1:1

Current - Output High, Low:

-

Voltage - Supply:

4V ~ 5.5V

Mounting Type:

Surface Mount

Supplier Device Package:

20-QSOP

## Environmental & Export classification

Moisture Sensitivity Level (MSL):

1 (Unlimited)

ECCN:

EAR99

REACH Status:

REACH Unaffected

HTSUS:

8542.39.0001



Is Now Part of



**ON Semiconductor®**

To learn more about ON Semiconductor, please visit our website at  
[www.onsemi.com](http://www.onsemi.com)

Please note: As part of the Fairchild Semiconductor integration, some of the Fairchild orderable part numbers will need to change in order to meet ON Semiconductor's system requirements. Since the ON Semiconductor product management systems do not have the ability to manage part nomenclature that utilizes an underscore (\_), the underscore (\_) in the Fairchild part numbers will be changed to a dash (-). This document may contain device numbers with an underscore (\_). Please check the ON Semiconductor website to verify the updated device numbers. The most current and up-to-date ordering information can be found at [www.onsemi.com](http://www.onsemi.com). Please email any questions regarding the system integration to [Fairchild\\_questions@onsemi.com](mailto:Fairchild_questions@onsemi.com).

ON Semiconductor and the ON Semiconductor logo are trademarks of Semiconductor Components Industries, LLC dba ON Semiconductor or its subsidiaries in the United States and/or other countries. ON Semiconductor owns the rights to a number of patents, trademarks, copyrights, trade secrets, and other intellectual property. A listing of ON Semiconductor's product/patent coverage may be accessed at [www.onsemi.com/site/pdf/Patent-Marking.pdf](http://www.onsemi.com/site/pdf/Patent-Marking.pdf). ON Semiconductor reserves the right to make changes without further notice to any products herein. ON Semiconductor makes no warranty, representation or guarantee regarding the suitability of its products for any particular purpose, nor does ON Semiconductor assume any liability arising out of the application or use of any product or circuit, and specifically disclaims any and all liability, including without limitation special, consequential or incidental damages. Buyer is responsible for its products and applications using ON Semiconductor products, including compliance with all laws, regulations and safety requirements or standards, regardless of any support or applications information provided by ON Semiconductor. "Typical" parameters which may be provided in ON Semiconductor data sheets and/or specifications can and do vary in different applications and actual performance may vary over time. All operating parameters, including "Typicals" must be validated for each customer application by customer's technical experts. ON Semiconductor does not convey any license under its patent rights nor the rights of others. ON Semiconductor products are not designed, intended, or authorized for use as a critical component in life support systems or any FDA Class 3 medical devices or medical devices with a same or similar classification in a foreign jurisdiction or any devices intended for implantation in the human body. Should Buyer purchase or use ON Semiconductor products for any such unintended or unauthorized application, Buyer shall indemnify and hold ON Semiconductor and its officers, employees, subsidiaries, affiliates, and distributors harmless against all claims, costs, damages, and expenses, and reasonable attorney fees arising out of, directly or indirectly, any claim of personal injury or death associated with such unintended or unauthorized use, even if such claim alleges that ON Semiconductor was negligent regarding the design or manufacture of the part. ON Semiconductor is an Equal Opportunity/Affirmative Action Employer. This literature is subject to all applicable copyright laws and is not for resale in any manner.



December 2012

## FST3244 — 8-Bit Bus Switch

### Features

- 4  $\Omega$  Switch Connection between Two Ports
- Minimal Propagation Delay through the Switch
- Low  $I_{CC}$
- Zero Bounce in Flow-through Mode
- Control Inputs Compatible with TTL Level

### Description

The FST3244 switch provides eight-bits of high-speed, CMOS, TTL-compatible bus switching in a standard '244 pin-out. The low on resistance allows inputs to be connected to outputs without adding propagation delay or generating additional ground bounce noise.

The device is organized as two four-bit switches with separate /OE inputs. When /OE is LOW, the switch is ON and port A is connected to port B. When /OE is HIGH, the switch is OPEN and a high-impedance state exists between the two ports.

### Ordering Information

Part Number	Operating Temperature Range	Package	Packing Method
FST3244MTCX	-40 to +85°C	20-Lead Thin Shrink Small Outline Package (TSSOP), JEDEC MO-153, 4.4 mm Wide	Tape and Reel

### Logic Diagram

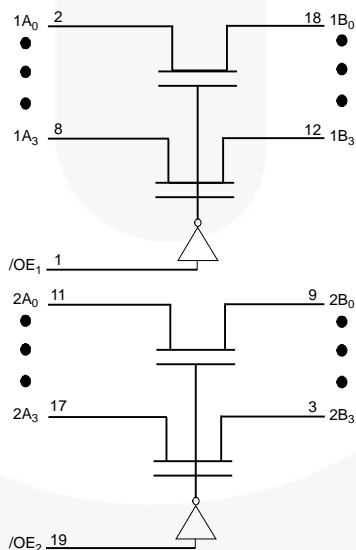

Figure 1. Logic Diagram

## Pin Configurations

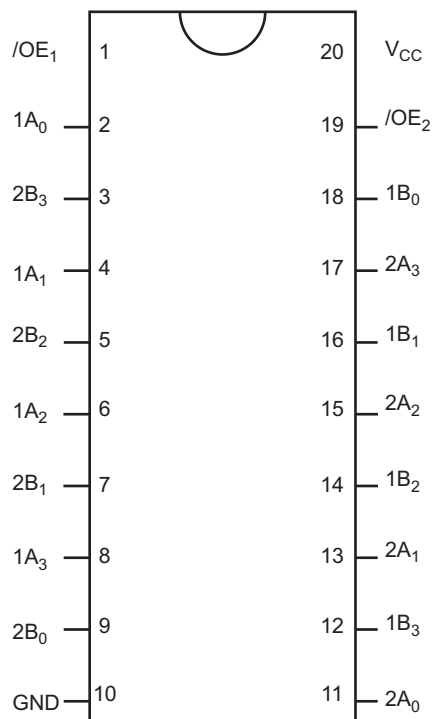

Figure 2. Pin Configuration

## Pin Descriptions

Pin #	Pin Names	Description
1,19	$\overline{OE}_1, \overline{OE}_2$	Bus Switch Enables
2,4,6,8,11,13,15,17	1A, 2A	Bus A
3,5,7,9,12,14, 16,18	1B, 2B	Bus B
20	$V_{CC}$	Supply Voltage
10	GND	Ground

## Truth Table

Inputs		Inputs/Outputs	
$\overline{OE}_1$	$\overline{OE}_2$	1A, 1B	2A, 2B
LOW	LOW	1A = 1B	2A = 2B
LOW	HIGH	1A = 1B	High Impedance
HIGH	LOW	High Impedance	2A = 2B
HIGH	HIGH	High Impedance	High Impedance

## Absolute Maximum Ratings

Stresses exceeding the absolute maximum ratings may damage the device. The device may not function or be operable above the recommended operating conditions and stressing the parts to these levels is not recommended. In addition, extended exposure to stresses above the recommended operating conditions may affect device reliability. The absolute maximum ratings are stress ratings only.

Symbol	Parameter	Min.	Max.	Unit
$V_{CC}$	Supply Voltage	-0.5	7.0	V
$V_S$	DC Switch Voltage	-0.5	7.0	V
$V_{IN}$	DC Input Voltage <sup>(1)</sup>	-0.5	7.0	V
$I_{IK}$	DC Input Diode Current $V_{IN} < 0$ V		-50	mA
$I_{OUT}$	DC Output Sink Current		128	mA
$I_{CC} / I_{GND}$	DC $V_{CC} / GND$ Current		±100	mA
$T_{STG}$	Storage Temperature Range	-65	+150	°C

### Note:

- The input and output negative voltage ratings may be exceeded if the input and output diode current ratings are observed.

## Recommended Operating Conditions

The Recommended Operating Conditions table defines the conditions for actual device operation. Recommended operating conditions are specified to ensure optimal performance to the datasheet specifications. Fairchild does not recommend exceeding them or designing to Absolute Maximum Ratings.

Symbol	Parameter	Min.	Max.	Unit	
$V_{CC}$	Power Supply Operating	4.0	5.5	V	
$V_{IN}$	Input Voltage	0	5.5	V	
$V_{OUT}$	Output Voltage	0	5.5	V	
$t_r, t_f$	Input Rise and Fall Time	Switch Control Input <sup>(2)</sup>	0	5	ns/V
		Switch I/O	0	DC	
$T_A$	Operating Temperature, Free Air	-40	+85	°C	

### Note:

- Unused control inputs must be held HIGH or LOW. They may not float.

## DC Electrical Characteristics

Typical values are at  $V_{CC} = 5.0\text{ V}$  and  $T_A = 25^\circ\text{C}$ .

Symbol	Parameter	Conditions	$V_{CC}$ (V)	$T_A = -40\text{ to }+85^\circ\text{C}$			Units
				Min.	Typ.	Max.	
$V_{IK}$	Clamp Diode Voltage	$I_{IN} = -18\text{ mA}$	4.5			-1.2	V
$V_{IH}$	High-Level Input Voltage		4.0 to 5.5	2.0			V
$V_{IL}$	Low-Level Input Voltage		4.0 to 5.5			0.8	V
$I_{IN}$	Input Leakage Current	$0 \leq V_{IN} \leq 5.5\text{ V}$	5.5			$\pm 1.0$	$\mu\text{A}$
$I_{OZ}$	Off-state Leakage Current	$0 \leq A, B \leq V_{CC}$	5.5			$\pm 1.0$	$\mu\text{A}$
$R_{ON}$	Switch On Resistance <sup>(3)</sup>	$V_{IN} = 0\text{ V}, I_{IN} = 64\text{ mA}$	4.5		4	7	$\Omega$
		$V_{IN} = 0\text{ V}, I_{IN} = 30\text{ mA}$	4.5		4	7	
		$V_{IN} = 2.4\text{ V}, I_{IN} = 15\text{ mA}$	4.5		8	15	
		$V_{IN} = 2.4\text{ V}, I_{IN} = 15\text{ mA}$	4.0		11	20	
$I_{CC}$	Quiescent Supply Current	$V_{IN} = V_{CC}$ or GND, $I_{OUT} = 0$	5.5			3	$\mu\text{A}$
$\Delta I_{CC}$	Increase in $I_{CC}$ per Input	One Input at 3.4 V, Other Inputs at $V_{CC}$ or GND	5.5			2.5	mA

### Note:

3. Measured by the voltage drop between the A and B pins at the indicated current through the switch. On resistance is determined by the lower of the voltages on the A or B pins.

## AC Electrical Characteristics

$T_A = -40\text{ to }+85^\circ\text{C}$ ,  $C_L = 50\text{ pF}$ , and  $R_U = R_D = 500\ \Omega$ .

Symbol	Parameter	Conditions	$V_{CC} = 4.5 - 5.5\text{ V}$		$V_{CC} = 4.0\text{ V}$		Units	Figure
			Min.	Max.	Min.	Max.		
$t_{PHL}, t_{PLH}$	Propagation Delay Bus-to Bus <sup>(4)</sup>	$V_{IN} = \text{Open}$		0.25		0.25	ns	Figure 3 Figure 4
$t_{PZH}, t_{PZL}$	Output Enable Time	$V_{IN} = 7\text{ V}$ for $t_{PZL}$ $V_{IN} = \text{Open}$ for $t_{PZH}$	1.0	5.6		6.1	ns	Figure 3 Figure 4
$t_{PHZ}, t_{PLZ}$	Output Disable Time	$V_{IN} = 7\text{ V}$ for $t_{PLZ}$ $V_{IN} = \text{Open}$ for $t_{PHZ}$	1.0	6.2		5.6	ns	Figure 3 Figure 4

### Note:

4. This parameter is guaranteed by design, but is not tested. The bus switch contributes no propagation delay other than the RC delay of the typical on resistance of the switch and the 50 pF load capacitance when driven by an ideal voltage source (zero output impedance).

## Capacitance

$T_A = +25^\circ\text{C}$ ,  $f = 1\text{ MHz}$ . Capacitance is characterized, but not tested.

Symbol	Parameter	Conditions	Typ.	Units
$C_{IN}$	Control Pin Input Capacitance	$V_{CC} = 5.0\text{ V}$	3	pF
$C_{I/O}$	Input/Output Capacitance	$V_{CC}, /OE = 5.0\text{ V}$	5	pF

### AC Loadings and Waveforms

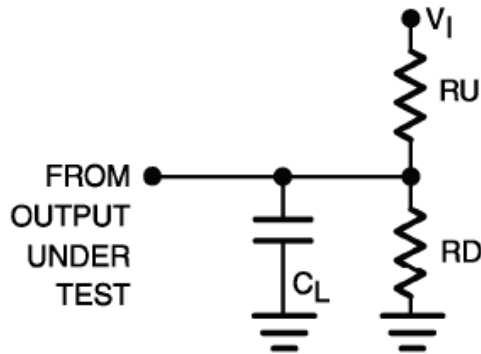

**Notes:** Input driven by  $50\ \Omega$  source terminated in  $50\ \Omega$ .  
 $C_L$  includes load and stray capacitance.  
 Input PRR = 1.0 MHz,  $t_w = 500\ \text{ns}$ .

Figure 3. AC Test Circuit

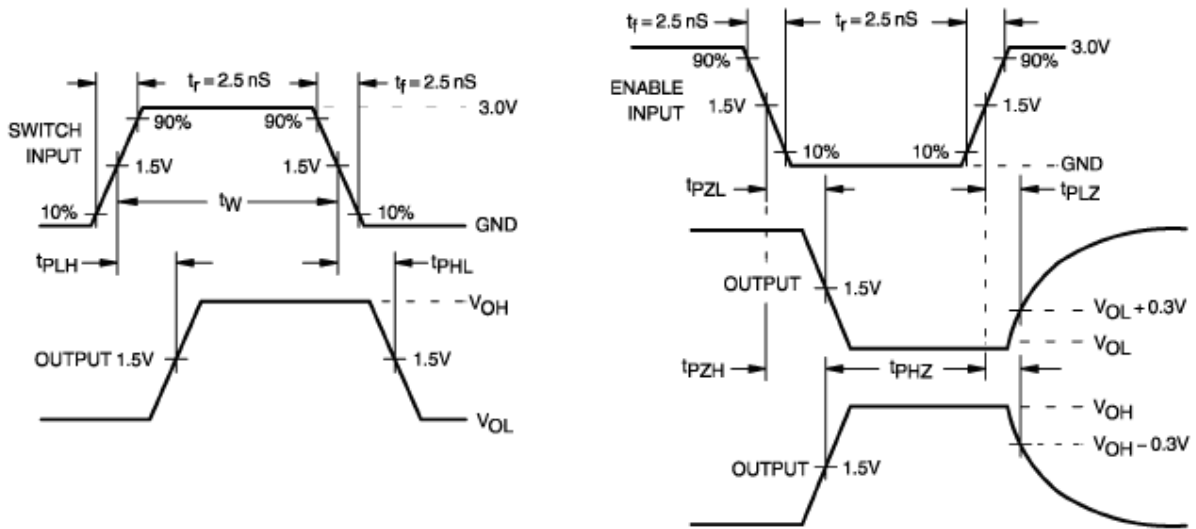
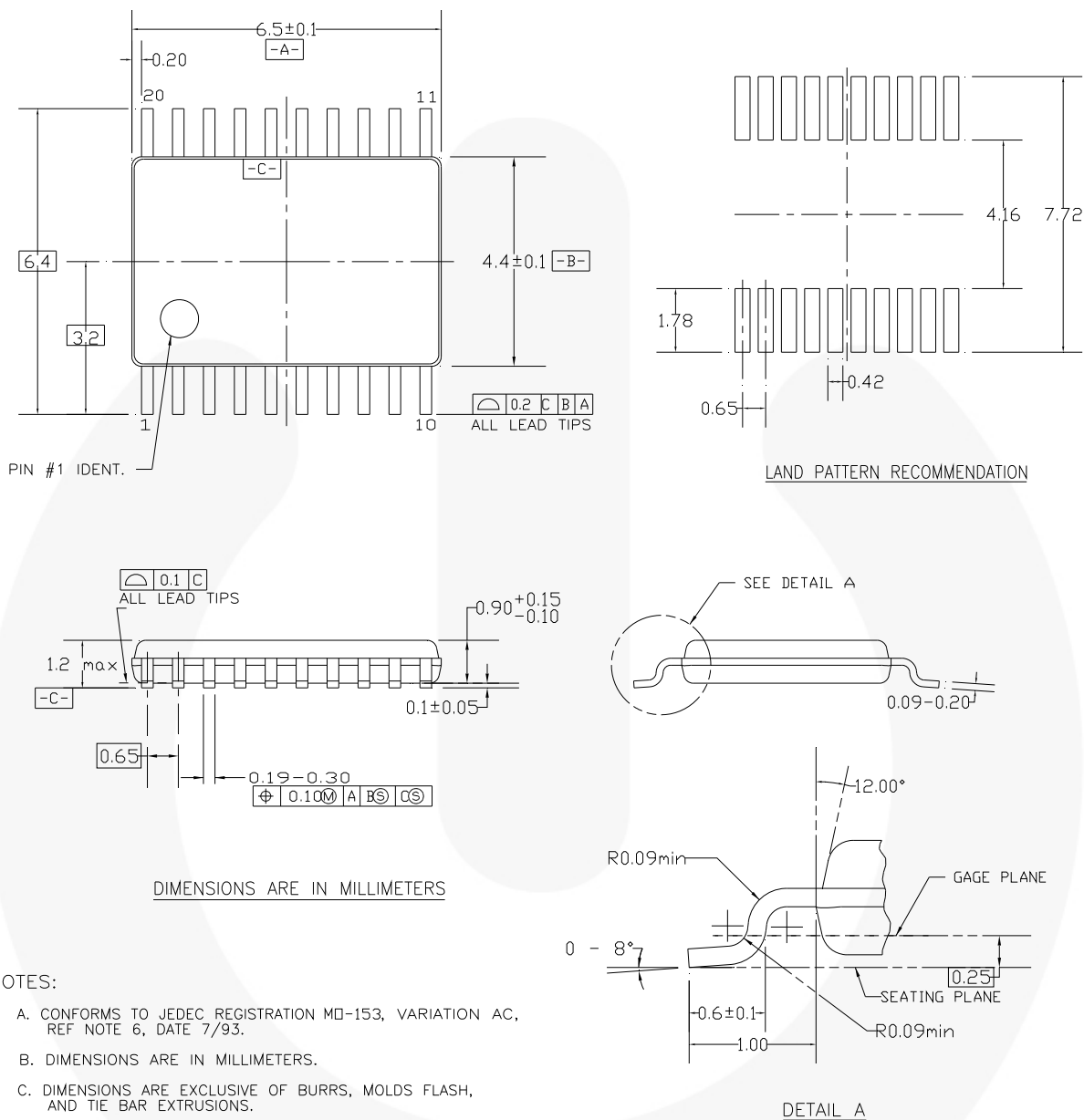

Figure 4. AC Waveforms

Physical Dimensions



MTC20REV D1

Figure 5. 20-Lead Thin Shrink Small Outline Package (TSSOP), JEDEC MO-153, 4.4 mm Wide

Package drawings are provided as a service to customers considering Fairchild components. Drawings may change in any manner without notice. Please note the revision and/or date on the drawing and contact a Fairchild Semiconductor representative to verify or obtain the most recent revision. Package specifications do not expand the terms of Fairchild's worldwide terms and conditions, specifically the warranty therein, which covers Fairchild products.

Always visit Fairchild Semiconductor's online packaging area for the most recent package drawings:

<http://www.fairchildsemi.com/packaging/>



**TRADEMARKS**

The following includes registered and unregistered trademarks and service marks, owned by Fairchild Semiconductor and/or its global subsidiaries, and is not intended to be an exhaustive list of all such trademarks.

- |  |   |   |   |
|--|---|---|---|
| 2Cool™   | F-PFS™  | PowerTrench®  | The Power Franchise®  |
| AccuPower™   | FRFET®  | PowerXS™  | <b>the Power franchise</b>  |
| AX-CAP™*   | Global Power Resource™  | Programmable Active Droop™  | TinyBoost™  |
| BitSIC™  | GreenBridge™  | QFET®   | TinyBuck™   |
| Build it Now™  | Green FPS™  | QST™  | TinyCalc™   |
| CorePLUSTM   | Green FPS™ e-Series™  | Quiet Series™   | TinyLogic®  |
| CorePOWER™   | Gmax™   | RapidConfigure™   | TINYOPTO™   |
| CROSSVOLT™   | GTO™  |  | TinyPower™  |
| CTL™   | IntelliMAX™   | Saving our world, 1mW/WKwV at a time™   | TinyPWM™  |
| Current Transfer Logic™  | ISOPLANAR™  | SignalWise™   | TinyWire™   |
| DEUXPEED®  | Making Small Speakers Sound Louder and Better™                                    | SmartMax™   | TranSIC™  |
| Dual Cool™   | MegaBuck™   | SMART START™  | TriFault Detect™  |
| EcoSPARK®  | MICROCOUPLER™   | Solutions for Your Success™   | TRUECURRENT®  |
| EfficientMax™  | MicroFET™   | SPM®  | µSerDes™  |
| ESBC™  | MicroPak™   | STEALTH™  |  |
|  Fairchild® | MicroPak2™  | SuperFET®   | UHC®  |
| Fairchild Semiconductor®   | MillerDrive™  | SuperSOT™-3   | Ultra FRFET™  |
| FACT Quiet Series™   | MotionMax™  | SuperSOT™-8   | UniFET™   |
| FACT®  | mVWSaver™   | SuperSOT™-8   | Vcx™  |
| FAST®  | OptoHiT™  | SupreMOS®   | VisualMax™  |
| FastvCore™   | OPTOLOGIC®  | SyncFET™  | VoltagePlus™  |
| FETBench™  | OPTOPLANAR®   | Sync-Lock™  | XST™  |
| FPS™   |  |  |   |

\* Trademarks of System General Corporation, used under license by Fairchild Semiconductor.

**DISCLAIMER**

FAIRCHILD SEMICONDUCTOR RESERVES THE RIGHT TO MAKE CHANGES WITHOUT FURTHER NOTICE TO ANY PRODUCTS HEREIN TO IMPROVE RELIABILITY, FUNCTION, OR DESIGN. FAIRCHILD DOES NOT ASSUME ANY LIABILITY ARISING OUT OF THE APPLICATION OR USE OF ANY PRODUCT OR CIRCUIT DESCRIBED HEREIN, NEITHER DOES IT CONVEY ANY LICENSE UNDER ITS PATENT RIGHTS, NOR THE RIGHTS OF OTHERS. THESE SPECIFICATIONS DO NOT EXPAND THE TERMS OF FAIRCHILD'S WORLDWIDE TERMS AND CONDITIONS, SPECIFICALLY THE WARRANTY THEREIN, WHICH COVERS THESE PRODUCTS.

**LIFE SUPPORT POLICY**

FAIRCHILD'S PRODUCTS ARE NOT AUTHORIZED FOR USE AS CRITICAL COMPONENTS IN LIFE SUPPORT DEVICES OR SYSTEMS WITHOUT THE EXPRESS WRITTEN APPROVAL OF FAIRCHILD SEMICONDUCTOR CORPORATION.

As used herein:

1. Life support devices or systems are devices or systems which, (a) are intended for surgical implant into the body or (b) support or sustain life, and (c) whose failure to perform when properly used in accordance with instructions for use provided in the labeling, can be reasonably expected to result in a significant injury of the user.
2. A critical component in any component of a life support, device, or system whose failure to perform can be reasonably expected to cause the failure of the life support device or system, or to affect its safety or effectiveness.

**ANTI-COUNTERFEITING POLICY**

Fairchild Semiconductor Corporation's Anti-Counterfeiting Policy. Fairchild's Anti-Counterfeiting Policy is also stated on our external website, [www.fairchildsemi.com](http://www.fairchildsemi.com), under Sales Support.

Counterfeiting of semiconductor parts is a growing problem in the industry. All manufacturers of semiconductor products are experiencing counterfeiting of their parts. Customers who inadvertently purchase counterfeit parts experience many problems such as loss of brand reputation, substandard performance, failed applications, and increased cost of production and manufacturing delays. Fairchild is taking strong measures to protect ourselves and our customers from the proliferation of counterfeit parts. Fairchild strongly encourages customers to purchase Fairchild parts either directly from Fairchild or from Authorized Fairchild Distributors who are listed by country on our web page cited above. Products customers buy either from Fairchild directly or from Authorized Fairchild Distributors are genuine parts, have full traceability, meet Fairchild's quality standards for handling and storage and provide access to Fairchild's full range of up-to-date technical and product information. Fairchild and our Authorized Distributors will stand behind all warranties and will appropriately address any warranty issues that may arise. Fairchild will not provide any warranty coverage or other assistance for parts bought from Unauthorized Sources. Fairchild is committed to combat this global problem and encourage our customers to do their part in stopping this practice by buying direct or from authorized distributors.

**PRODUCT STATUS DEFINITIONS**

**Definition of Terms**

Datasheet Identification	Product Status	Definition
Advance Information	Formative / In Design	Datasheet contains the design specifications for product development. Specifications may change in any manner without notice.
Preliminary	First Production	Datasheet contains preliminary data; supplementary data will be published at a later date. Fairchild Semiconductor reserves the right to make changes at any time without notice to improve design.
No Identification Needed	Full Production	Datasheet contains final specifications. Fairchild Semiconductor reserves the right to make changes at any time without notice to improve the design.
Obsolete	Not In Production	Datasheet contains specifications on a product that is discontinued by Fairchild Semiconductor. The datasheet is for reference information only.

Rev. I63

ON Semiconductor and  are trademarks of Semiconductor Components Industries, LLC dba ON Semiconductor or its subsidiaries in the United States and/or other countries. ON Semiconductor owns the rights to a number of patents, trademarks, copyrights, trade secrets, and other intellectual property. A listing of ON Semiconductor's product/patent coverage may be accessed at [www.onsemi.com/site/pdf/Patent-Marking.pdf](http://www.onsemi.com/site/pdf/Patent-Marking.pdf). ON Semiconductor reserves the right to make changes without further notice to any products herein. ON Semiconductor makes no warranty, representation or guarantee regarding the suitability of its products for any particular purpose, nor does ON Semiconductor assume any liability arising out of the application or use of any product or circuit, and specifically disclaims any and all liability, including without limitation special, consequential or incidental damages. Buyer is responsible for its products and applications using ON Semiconductor products, including compliance with all laws, regulations and safety requirements or standards, regardless of any support or applications information provided by ON Semiconductor. "Typical" parameters which may be provided in ON Semiconductor data sheets and/or specifications can and do vary in different applications and actual performance may vary over time. All operating parameters, including "Typicals" must be validated for each customer application by customer's technical experts. ON Semiconductor does not convey any license under its patent rights nor the rights of others. ON Semiconductor products are not designed, intended, or authorized for use as a critical component in life support systems or any FDA Class 3 medical devices or medical devices with a same or similar classification in a foreign jurisdiction or any devices intended for implantation in the human body. Should Buyer purchase or use ON Semiconductor products for any such unintended or unauthorized application, Buyer shall indemnify and hold ON Semiconductor and its officers, employees, subsidiaries, affiliates, and distributors harmless against all claims, costs, damages, and expenses, and reasonable attorney fees arising out of, directly or indirectly, any claim of personal injury or death associated with such unintended or unauthorized use, even if such claim alleges that ON Semiconductor was negligent regarding the design or manufacture of the part. ON Semiconductor is an Equal Opportunity/Affirmative Action Employer. This literature is subject to all applicable copyright laws and is not for resale in any manner.

## PUBLICATION ORDERING INFORMATION

### LITERATURE FULFILLMENT:

Literature Distribution Center for ON Semiconductor  
19521 E. 32nd Pkwy, Aurora, Colorado 80011 USA  
**Phone:** 303-675-2175 or 800-344-3860 Toll Free USA/Canada  
**Fax:** 303-675-2176 or 800-344-3867 Toll Free USA/Canada  
**Email:** [orderlit@onsemi.com](mailto:orderlit@onsemi.com)

**N. American Technical Support:** 800-282-9855 Toll Free  
USA/Canada  
**Europe, Middle East and Africa Technical Support:**  
Phone: 421 33 790 2910  
**Japan Customer Focus Center**  
Phone: 81-3-5817-1050

**ON Semiconductor Website:** [www.onsemi.com](http://www.onsemi.com)

**Order Literature:** <http://www.onsemi.com/orderlit>

For additional information, please contact your local Sales Representative

## OUR CERTIFICATE

DiGi provide top-quality products and perfect service for customer worldwide through standardization, technological innovation and continuous improvement. DiGi through third-party certification, we stricly control the quality of products and services. Welcome your RFQ to

Email: [Info@DiGi-Electronics.com](mailto:Info@DiGi-Electronics.com)



Tel: +00 852-30501935

RFQ Email: [Info@DiGi-Electronics.com](mailto:Info@DiGi-Electronics.com)

DiGi is a global authorized distributor of electronic components.