

H11AA814A300W Datasheet



<https://www.DiGi-Electronics.com>

DiGi Electronics Part Number	H11AA814A300W-DG
Manufacturer	onsemi
Manufacturer Product Number	H11AA814A300W
Description	OPTOISO 5.3KV TRANSISTOR 4DIP
Detailed Description	Optoisolator Transistor Output 5300Vrms 1 Channel 4-DIP

This model H11AA814A300W is available at DiGi Electronics.

DiGi Electronics offers a global database of semiconductor and electronic component datasheets.

We welcome your inquiries regarding pricing, lead time, or other product-related questions.

 [Request a Quote](#)

 [Datasheet Search](#)



Tel: +00 852-30501935

RFQ Email: Info@DiGi-Electronics.com

DiGi is a global authorized distributor of electronic components.

Purchase and inquiry

Manufacturer Product Number:

H11AA814A300W

Series:

-

Number of Channels:

1

Current Transfer Ratio (Min):

50% @ 1mA

Turn On / Turn Off Time (Typ):

-

Input Type:

AC, DC

Voltage - Output (Max):

70V

Voltage - Forward (Vf) (Typ):

1.2V

Vce Saturation (Max):

200mV

Mounting Type:

Through Hole

Supplier Device Package:

4-DIP

Manufacturer:

onsemi

Product Status:

Obsolete

Voltage - Isolation:

5300Vrms

Current Transfer Ratio (Max):

150% @ 1mA

Rise / Fall Time (Typ):

2.4µs, 2.4µs

Output Type:

Transistor

Current - Output / Channel:

50mA

Current - DC Forward (If) (Max):

50 mA

Operating Temperature:

-55°C ~ 100°C

Package / Case:

4-DIP (0.400", 10.16mm)

Base Product Number:

H11A

Environmental & Export classification

Moisture Sensitivity Level (MSL):

1 (Unlimited)

ECCN:

EAR99

REACH Status:

REACH Unaffected

HTSUS:

8541.49.8000

H11AA814 SERIES

H11A617 SERIES

H11A817 SERIES

PACKAGE

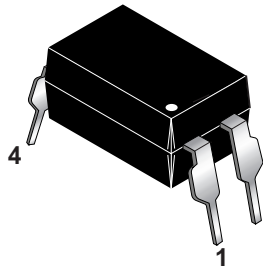

H11AA814 SCHEMATIC

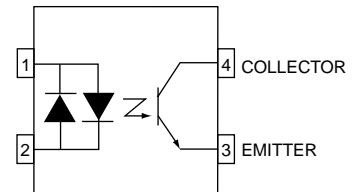

DESCRIPTION

The H11AA814 Series consists of two gallium arsenide infrared emitting diodes, connected in inverse parallel, driving a single silicon phototransistor in a 4-pin dual in-line package.

The H11A617 and H11A817 Series consists of a gallium arsenide infrared emitting diode driving a silicon phototransistor in a 4-pin dual in-line package.

FEATURES

- Compact 4-pin package
- Current transfer ratio in selected groups:

H11AA814:	20-300%	H11A817:	50-600%
H11AA814A:	50-150%	H11A817A:	80-160%
H11A617A:	40%-80%	H11A817B:	130-260%
H11A617B:	63%-125%	H11A817C:	200-400%
H11A617C:	100%-200%	H11A817D:	300-600%
H11A617D:	160%-320%		
- Minimum BV_{CEO} of 70V guaranteed

APPLICATIONS

H11AA814 Series

- AC line monitor
- Unknown polarity DC sensor
- Telephone line interface

H11A617 and H11A817 Series

- Power supply regulators
- Digital logic inputs
- Microprocessor inputs

H11A617 & H11A817 SCHEMATIC

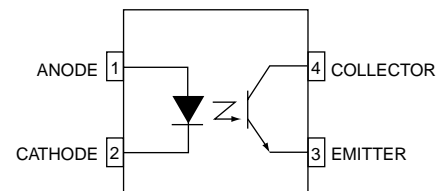



4-PIN PHOTOTRANSISTOR OPTOCOUPLEDERS

H11AA814 SERIES

H11A617 SERIES

H11A817 SERIES

Parameter	Symbol	Device	Value	Units
TOTAL DEVICE				
Storage Temperature	T_{STG}	All	-55 to +150	°C
Operating Temperature	T_{OPR}	All	-55 to +100	°C
Lead Solder Temperature	T_{SOL}	All	260 for 10 sec	°C
Total Device Power Dissipation (-55°C to 50 °C)	P_D	All	200	mW
EMITTER				
Continuous Forward Current	I_F	All	50	mA
Reverse Voltage	V_R	H11A617A/B/C/D H11A817/A/B/C/D	6 5	V
Forward Current - Peak (1 μ s pulse, 300 pps)	$I_F(pk)$	All	1.0	A
LED Power Dissipation (25°C ambient) Derate above 25°C	P_D	All	100 1.33	mW mW/°C
DETECTOR				
Collector-Emitter Voltage	V_{CEO}	All	70	V
Emitter-Collector Voltage	V_{ECO}	H11AA814/A H11A617A/B/C/D H11A817/A/B/C/D	6 7 6	V
Continuous Collector Current	I_C	All	50	mA
Detector Power Dissipation (25°C ambient) Derate above 25°C	P_D	All	150 2.0	mW mW/°C

ELECTRICAL CHARACTERISTICS ($T_A = 25^\circ\text{C}$ Unless otherwise specified.)

INDIVIDUAL COMPONENT CHARACTERISTICS

Parameter	Test Conditions	Symbol	Device	Min	Typ*	Max	Unit
EMITTER							
Input Forward Voltage	$(I_F = 60 \text{ mA})$	V_F	H11A617A/B/C/D		1.35	1.65	V
	$(I_F = 20 \text{ mA})$		H11A817/A/B/C/D		1.2	1.5	
	$(I_F = \pm 20 \text{ mA})$		H11AA814/A		1.2	1.5	
Reverse Leakage Current	$(V_R = 6.0 \text{ V})$	I_R	H11A617A/B/C/D		.001	10	μA
	$(V_R = 5.0 \text{ V})$		H11A817/A/B/C/D				
DETECTOR							
Collector-Emitter Breakdown Voltage	$(I_C = 1.0 \text{ mA}, I_F = 0)$	BV_{CEO}	ALL	70	100		V
Emitter-Collector Breakdown Voltage	$(I_E = 100 \mu\text{A}, I_F = 0)$	BV_{ECO}	H11AA814/A	6	10		V
			H11A617A/B/C/D	7			
			H11A817/A/B/C/D	6			
Collector-Emitter Dark Current	$(V_{CE} = 10\text{V}, I_F = 0)$	I_{CEO}	H11AA814/A, H11A817/A/B/C/D, H11A617C/D		1	100	nA
			H11A617A/B			50	
Collector-Emitter Capacitance	$(V_{CE} = 0 \text{ V}, f = 1 \text{ MHz})$	C_{CE}	ALL		8		pF

*Typical values at $T_A = 25^\circ\text{C}$.



4-PIN PHOTOTRANSISTOR OPTOCOUPLEDERS

H11AA814 SERIES

H11A617 SERIES

H11A817 SERIES

TRANSFER CHARACTERISTICS ($T_A = 25^\circ\text{C}$ Unless otherwise specified.)							
DC Characteristic	Test Conditions	Symbol	Device	Min	Typ*	Max	Unit
Current Transfer Ratio	$(I_F = \pm 1 \text{ mA}, V_{CE} = 5 \text{ V})$ (note 1)	CTR	H11AA814	20		300	%
	$(I_F = \pm 1 \text{ mA}, V_{CE} = 5 \text{ V})$ (note 1)		H11AA814A	50		150	%
	$(I_F = 10 \text{ mA}, V_{CE} = 5 \text{ V})$ (note 1)		H11A617A	40		80	%
			H11A617B	63		125	%
			H11A617C	100		200	%
			H11A617D	160		320	%
	$(I_F = 5 \text{ mA}, V_{CE} = 5 \text{ V})$ (note 1)		H11A817	50		600	%
			H11A817A	80		160	%
			H11A817B	130		260	%
			H11A817C	200		400	%
	$(I_F = 1 \text{ mA}, V_{CE} = 5 \text{ V})$ (note 1)		H11A817D	300		600	%
			H11A617A	13			%
			H11A617B	22			%
			H11A617C	34			%
Collector-Emitter Saturation Voltage	$(I_C = 1 \text{ mA}, I_F = \pm 20 \text{ mA})$ $(I_C = 2.5 \text{ mA}, I_F = 10 \text{ mA})$ $(I_C = 1 \text{ mA}, I_F = 20 \text{ mA})$	$V_{CE(SAT)}$	H11AA814/A			0.2	V
			H11A617A/B/C/D			0.4	
			H11A817/A/B/C/D			0.2	
AC Characteristic							
Rise Time	$(I_C = 2 \text{ mA}, V_{CE} = 2 \text{ V}, R_L = 100\Omega)$ (note 2)	t_r	ALL		2.4	18	μs
Fall Time	$(I_C = 2 \text{ mA}, V_{CE} = 2 \text{ V}, R_L = 100\Omega)$ (note 2)	t_f	ALL		2.4	18	μs

ISOLATION CHARACTERISTICS						
Characteristic	Test Conditions	Symbol	Min	Typ*	Max	Units
Input-Output Isolation Voltage (note 3)	$f = 60\text{Hz}, t = 1 \text{ min}$	V_{ISO}	5300			Vac(rms)
Isolation Resistance	$(V_{I-O} = 500 \text{ VDC})$	R_{ISO}	10^{11}			Ω
Isolation Capacitance	$(V_{I-O} = 0, f = 1 \text{ MHz})$	C_{ISO}		0.5		pf

*Typical values at $T_A = 25^\circ\text{C}$.

NOTES

1. Current Transfer Ratio (CTR) = $I_C/I_F \times 100\%$.
2. For test circuit setup and waveforms, refer to Figure 8.
3. For this test, Pins 1 and 2 are common, and Pins 3 and 4 are common.



4-PIN PHOTOTRANSISTOR OPTOCOUPLEDERS

H11AA814 SERIES

H11A617 SERIES

H11A817 SERIES

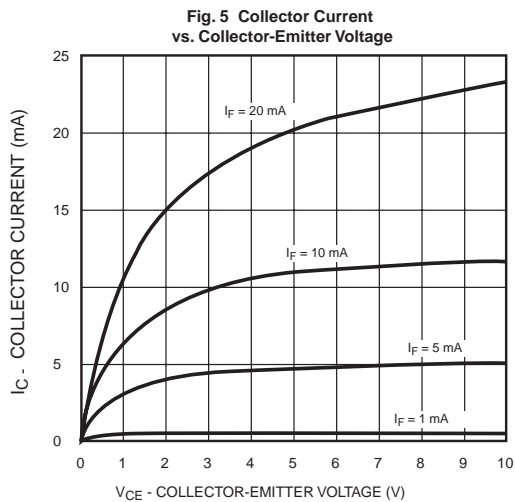
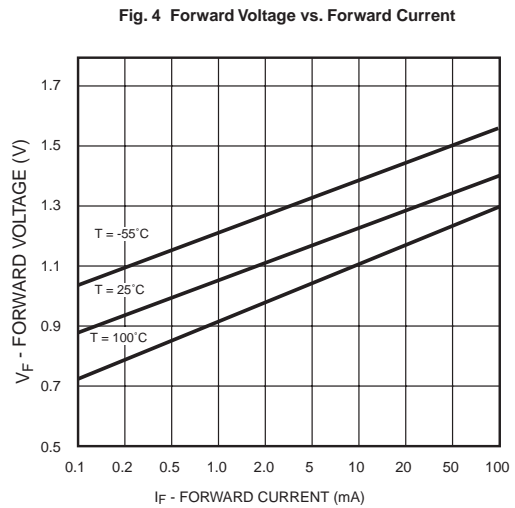
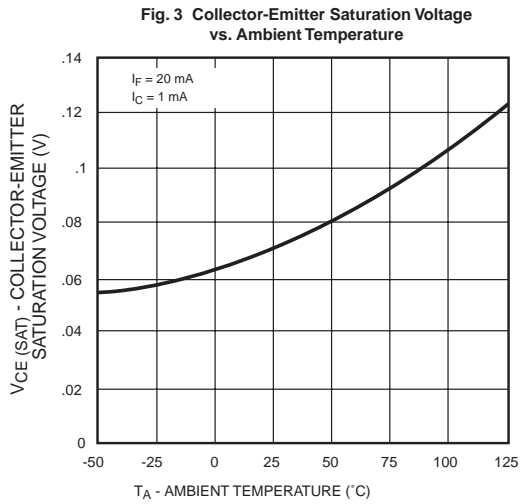
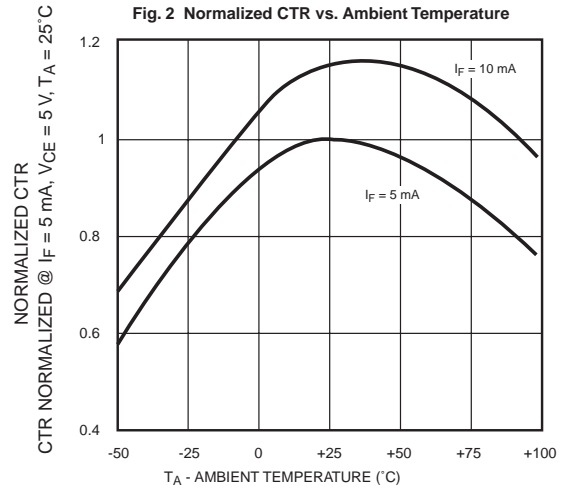
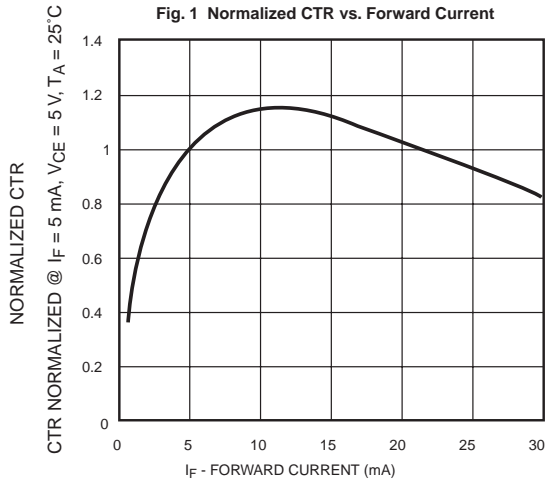



4-PIN PHOTOTRANSISTOR OPTOCOUPLEDERS

H11AA814 SERIES

H11A617 SERIES

H11A817 SERIES

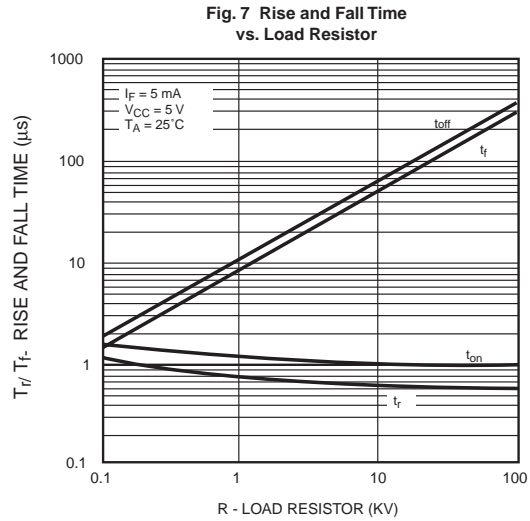
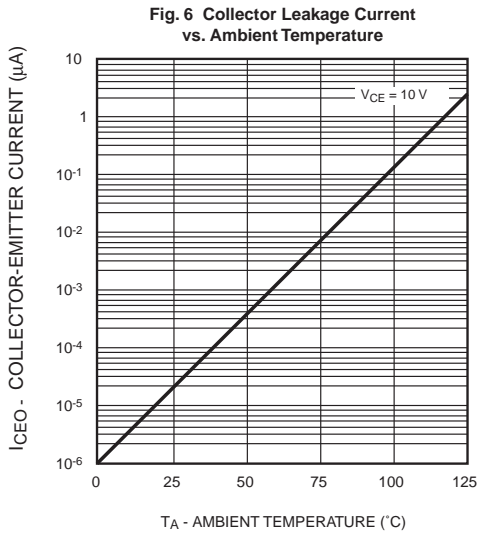
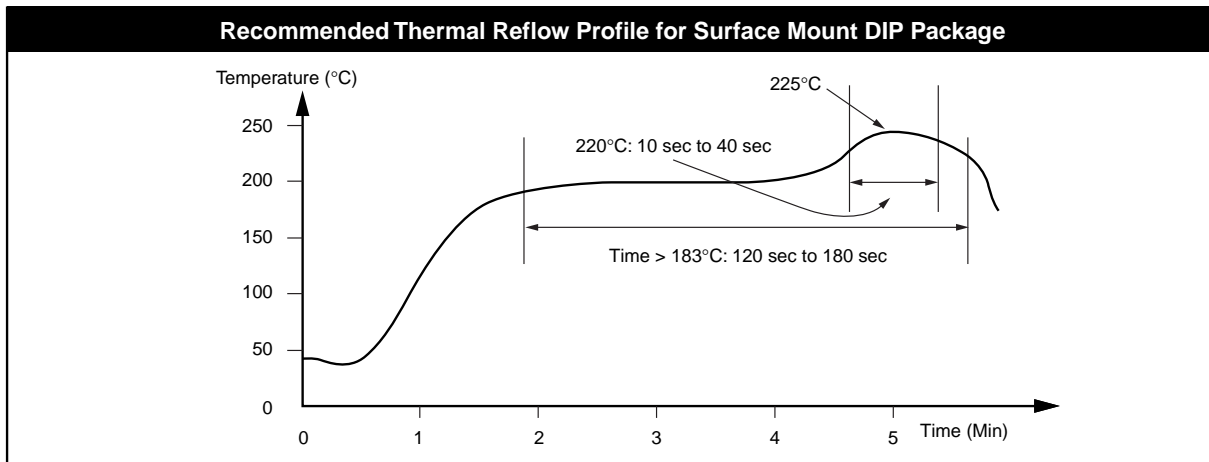
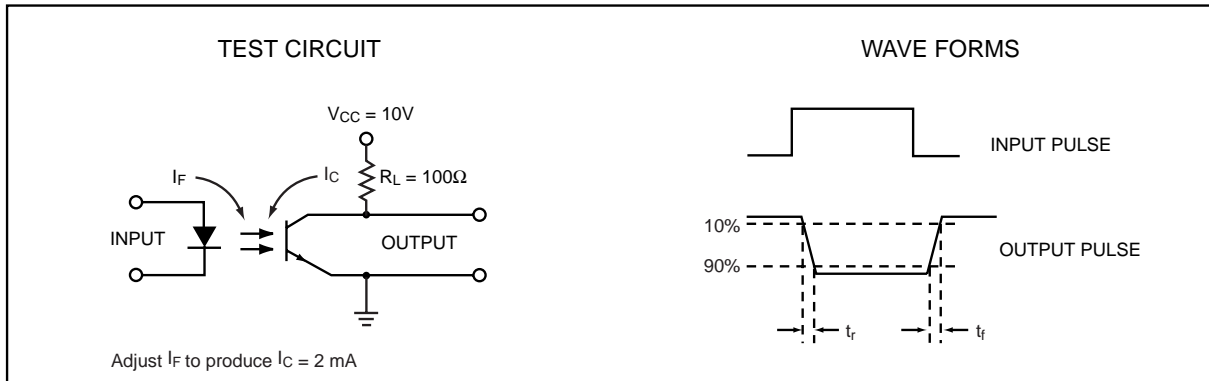

Figure 8. Switching Time Test Circuit and Waveforms





4-PIN PHOTOTRANSISTOR OPTOCOUPLEDERS

H11AA814 SERIES

H11A617 SERIES

H11A817 SERIES

Package Dimensions (Through Hole)

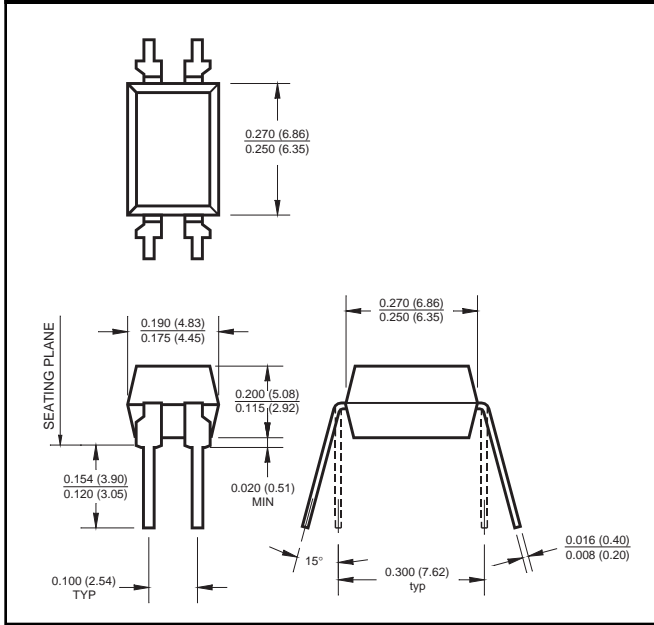

Package Dimensions (Surface Mount)

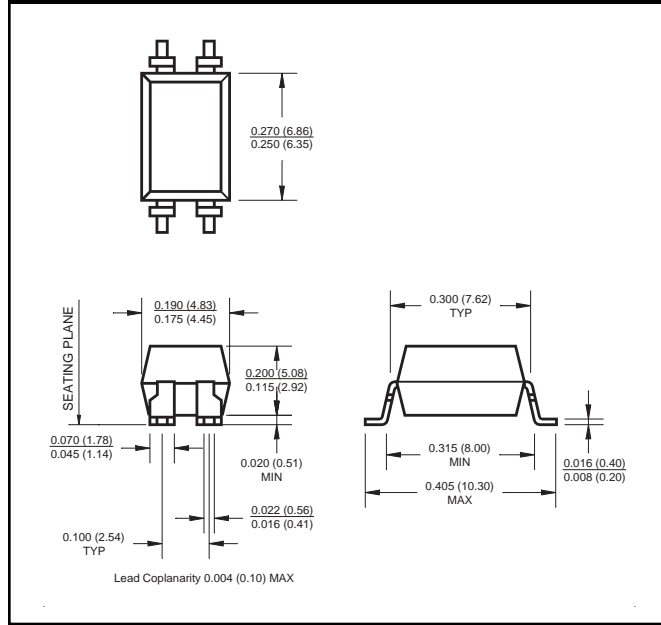

Package Dimensions (0.4" Lead Spacing)

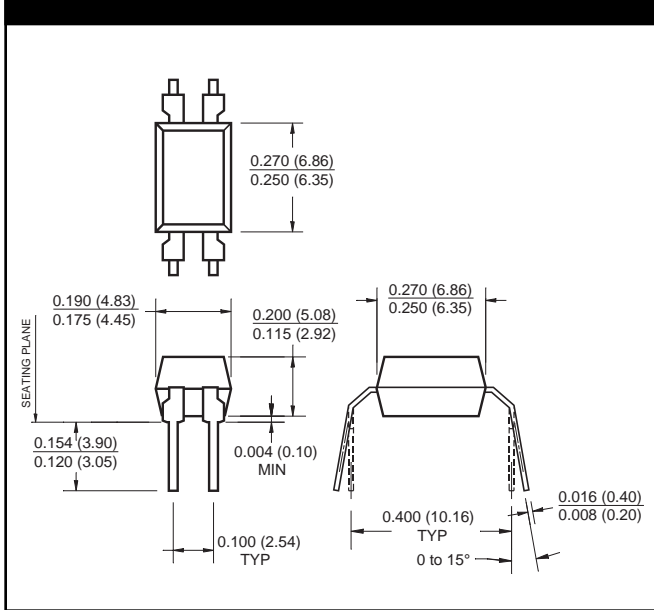

Footprint Dimensions (Surface Mount)

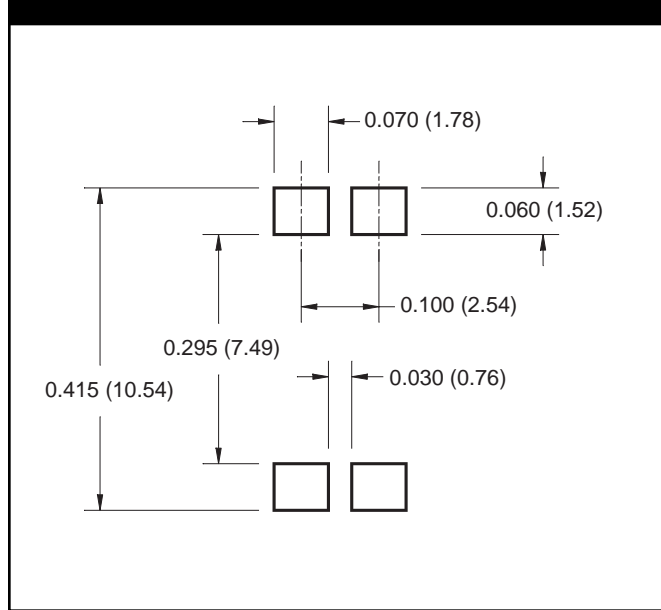

NOTE

All dimensions are in inches (millimeters)



4-PIN PHOTOTRANSISTOR OPTOCOUPLEDERS

H11AA814 SERIES
H11A617 SERIES
H11A817 SERIES
ORDERING INFORMATION

Option	Order Entry Identifier	Description
S	.S	Surface Mount Lead Bend
SD	.SD	Surface Mount; Tape and reel
W	.W	0.4" Lead Spacing
300	.300	VDE 0884
300W	.300W	VDE 0884, 0.4" Lead Spacing
3S	.3S	VDE 0884, Surface Mount
3SD	.3SD	VDE 0884, Surface Mount, Tape & Reel

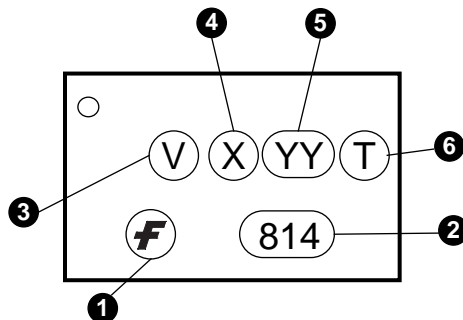
MARKING INFORMATION

Definitions	
1	Fairchild logo
2	Device number
3	VDE mark (Note: Only appears on parts ordered with VDE option – See order entry table)
4	One digit year code
5	Two digit work week ranging from '01' to '53'
6	Assembly package code



4-PIN PHOTOTRANSISTOR OPTOCOUPERS

H11AA814 SERIES**H11A617 SERIES****H11A817 SERIES**

DISCLAIMER

FAIRCHILD SEMICONDUCTOR RESERVES THE RIGHT TO MAKE CHANGES WITHOUT FURTHER NOTICE TO ANY PRODUCTS HEREIN TO IMPROVE RELIABILITY, FUNCTION OR DESIGN. FAIRCHILD DOES NOT ASSUME ANY LIABILITY ARISING OUT OF THE APPLICATION OR USE OF ANY PRODUCT OR CIRCUIT DESCRIBED HEREIN; NEITHER DOES IT CONVEY ANY LICENSE UNDER ITS PATENT RIGHTS, NOR THE RIGHTS OF OTHERS.

LIFE SUPPORT POLICY

FAIRCHILD'S PRODUCTS ARE NOT AUTHORIZED FOR USE AS CRITICAL COMPONENTS IN LIFE SUPPORT DEVICES OR SYSTEMS WITHOUT THE EXPRESS WRITTEN APPROVAL OF THE PRESIDENT OF FAIRCHILD SEMICONDUCTOR CORPORATION. As used herein:

1. Life support devices or systems are devices or systems which, (a) are intended for surgical implant into the body, or (b) support or sustain life, and (c) whose failure to perform when properly used in accordance with instructions for use provided in the labeling, can be reasonably expected to result in a significant injury of the user.
2. A critical component in any component of a life support device or system whose failure to perform can be reasonably expected to cause the failure of the life support device or system, or to affect its safety or effectiveness.

OUR CERTIFICATE

DiGi provide top-quality products and perfect service for customer worldwide through standardization, technological innovation and continuous improvement. DiGi through third-party certification, we stricly control the quality of products and services. Welcome your RFQ to

Email: Info@DiGi-Electronics.com



Tel: +00 852-30501935

RFQ Email: Info@DiGi-Electronics.com

DiGi is a global authorized distributor of electronic components.